

Manual

CX9020

Embedded PC

Version: 1.9
Date: 2018-01-31

BECKHOFF

Table of contents

1	Notes on the documentation	5
1.1	Explanation of symbols	6
1.2	Related documents	7
1.3	Documentation issue status	7
2	For your safety	8
2.1	Intended use	8
2.2	Staff qualification	9
2.3	Safety instructions	9
3	Transport and storage	11
4	Product overview	12
4.1	Structure of the CX9020 Embedded PC	13
4.2	Name plate	14
4.3	Types	15
4.4	Architecture overview	16
5	Description of the interfaces	17
5.1	USB (X100, X101, X102, X103)	17
5.2	Ethernet RJ45 (X000, X001)	18
5.3	DVI-D (X200)	19
5.4	Optional interfaces	20
5.4.1	Audio interface (N020)	20
5.4.2	RS232 (N030)	21
5.4.3	RS422/RS485 (N031)	22
5.4.4	EtherCAT slave (B110)	23
5.4.5	PROFIBUS (x310)	24
5.4.6	CANopen (x510)	25
5.4.7	PROFINET RT (x930)	26
6	Commissioning	27
6.1	Assembly	27
6.1.1	Note the permissible installation positions	27
6.1.2	Attaching on mounting rail	29
6.1.3	MicroSD card installation and removal	30
6.1.4	Installing passive EtherCAT Terminals	31
6.2	Connecting the power supply	32
6.3	Switching on	34
6.4	Switching off	34
7	Configuration	35
7.1	Windows Embedded Compact 7	35
7.1.1	Setting up the audio interface (N020)	35
7.2	Beckhoff Device Manager	36
7.2.1	Starting the Beckhoff Device Manager	36
7.2.2	Enabling a remote display	37
7.3	TwinCAT	38
7.3.1	Tree view	38
7.3.2	Searching for target systems	39
7.3.3	Adding an Embedded PC	41

8 NOVRAM	42
8.1 Use under TwinCAT 3	43
8.1.1 Creating a Retain Handler	43
8.1.2 Creating and linking variables	45
8.1.3 Note the write speed of the Retain Handler	47
8.1.4 Deleting variables under the Retain Handler	48
9 1-second UPS (persistent data)	49
9.1 FB_S_UPS_CX9020_U900	50
9.2 Mode and status of the function block	52
9.3 Checking the validity of the variables	53
9.3.1 SYSTEMINFOTYPE	53
9.3.2 PlcAppSystemInfo.....	55
10 Error handling and diagnostics	56
10.1 Diagnostic LEDs	56
10.2 Power supply terminal LEDs in K-bus mode	57
10.3 Power supply terminal LEDs in K-bus mode	60
10.4 Faults	61
11 Care and maintenance	62
11.1 Replace the battery.....	62
12 Decommissioning	63
12.1 Removing cables	63
12.2 Dismantling the Embedded PC.....	64
13 Technical data	65
14 Appendix	67
14.1 Accessories	67
14.2 Certifications	68
14.3 Support and Service	69
List of tables	70
List of figures	71

1 Notes on the documentation

This description is only intended for the use of trained specialists in control and automation engineering who are familiar with the applicable national standards.

It is essential that the documentation and the following notes and explanations are followed when installing and commissioning the components.

It is the duty of the technical personnel to use the documentation published at the respective time of each installation and commissioning.

The responsible staff must ensure that the application or use of the products described satisfy all the requirements for safety, including all the relevant laws, regulations, guidelines and standards.

Disclaimer

The documentation has been prepared with care. The products described are, however, constantly under development.

We reserve the right to revise and change the documentation at any time and without prior announcement.

No claims for the modification of products that have already been supplied may be made on the basis of the data, diagrams and descriptions in this documentation.

Trademarks

Beckhoff®, TwinCAT®, EtherCAT®, Safety over EtherCAT®, TwinSAFE®, XFC® and XTS® are registered trademarks of and licensed by Beckhoff Automation GmbH.

Other designations used in this publication may be trademarks whose use by third parties for their own purposes could violate the rights of the owners.

Patent Pending

The EtherCAT Technology is covered, including but not limited to the following patent applications and patents:

EP1590927, EP1789857, DE102004044764, DE102007017835

with corresponding applications or registrations in various other countries.

The TwinCAT Technology is covered, including but not limited to the following patent applications and patents:

EP0851348, US6167425 with corresponding applications or registrations in various other countries.



EtherCAT® is registered trademark and patented technology, licensed by Beckhoff Automation GmbH, Germany

Copyright

© Beckhoff Automation GmbH & Co. KG, Germany.



The reproduction, distribution and utilization of this document as well as the communication of its contents to others without express authorization are prohibited.

Offenders will be held liable for the payment of damages. All rights reserved in the event of the grant of a patent, utility model or design.

1.1 Explanation of symbols

The following symbols with corresponding warnings or explanatory text are used in the documentation. Read and follow the warnings.

Symbols that warn of personal injury:

 DANGER	Serious risk of injury Note this warning. Hazard with high risk of death or serious injury.
 WARNING	Risk of injury Note this warning. Hazard with medium risk of death or serious injury.
 CAUTION	Personal injuries Note this warning. Hazard with a low degree of risk, which could lead to minor or moderate injury.

Symbols that warn of damage to property or equipment:

 Attention	Damage to the devices or environment Note this warning. Risk of damage to the environment and equipment.
---	--

Symbols indicating further information or tips:

 Note	Tip or pointer This symbol indicates information that contributes to better understanding.
--	--

1.2 Related documents

Please refer to the corresponding documentation for important information and notes regarding operation of the CX9020 Embedded PCs in potentially explosive atmospheres. In particular, read and follow the section of safety contained in this document:

<http://www.beckhoff.de>

Document name
Notes on using the CX9020 in potentially explosive atmospheres.

Retaining the documentation

This documentation is part of the Embedded-PC. Keep the documentation in the immediate vicinity of the battery pack throughout its entire service life. Ensure that personnel have access to the documentation at all times. Pass on the documentation to subsequent users, and in addition ensure that all supplementary information is included in the documentation.

1.3 Documentation issue status

Version	Changes
0.1	Preliminary version.
1.0	First publication.
1.1	UPS chapter added.
1.2	UPS notes added.
1.3	Reworked images in chapter battery compartment.
1.4	Chapter Technical Data reworked.
1.5	Architecture overview added, Chapter Types reworked.
1.6	Chapter LAN connections reworked.
1.7	Chapter NOVRAM added, Chapter 1-second UPS reworked.
1.8	Documentation restructured and revised.
1.9	Information for operation in potentially explosive atmospheres added.

2 For your safety

Read the chapter on safety and follow the instructions in order to protect from personal injury and damage to equipment.

Limitation of liability

All the components are supplied in particular hardware and software configurations appropriate for the application. Unauthorized modifications and changes to the hardware or software configuration, which go beyond the documented options, are prohibited and nullify the liability of Beckhoff Automation GmbH & Co. KG.

In addition, the following actions are excluded from the liability of Beckhoff Automation GmbH & Co. KG:

- Failure to comply with this documentation.
- Improper use.
- Use of untrained personnel.
- Use of unauthorized replacement parts.

2.1 Intended use

The CX9020 Embedded PC is a control system designed for installation on a DIN rail in a control cabinet or terminal box. The Embedded PC series is used in conjunction with Bus Terminals for recording digital or analog signals from sensors and transferring them to actuators or higher-level controllers.

The Embedded PC is designed for a working environment that meets the requirements of protection class IP20. This involves finger protection and protection against solid foreign objects up to 12.5 mm, but not protection against water. Operation of the devices in wet and dusty environments is not permitted, unless specified otherwise. The specified limits for electrical and technical data must be adhered to.

Potentially explosive atmospheres

Device modification CX2900-0107 is mandatory for operation of the Embedded PC in potentially explosive atmospheres, zone 2/22. The device modification includes a factory-installed retainer bracket for mechanically securing the plug connectors.

The device modification is mandatory for operating the Embedded PC in the following potentially explosive atmospheres:

1. For Zone 2 atmospheres in which gas is present as a combustible material. Zone 2 means that an explosive atmosphere does usually not occur during normal operation, or only for a short time.
2. For Zone 22 atmospheres in which dust is present as a combustible material. Zone 22 means that an explosive atmosphere in the form of a cloud does usually not occur during normal operation, or only for a short time.

The Embedded PC must be installed in a housing, which ensures protection class IP 54 for gas according to EN 60079-15. A housing with protection class IP 54 is required for non-conductive dust. IP 6X is required for conductive dust according to EN 60079-31.

Improper use

The Embedded PC is not suitable for operation in the following areas:

- In potentially explosive atmospheres, the Embedded PC may not be used in other zones except for 2/22 and not without a suitable housing.
- Areas with an aggressive environment, e.g. aggressive gases or chemicals.
- Living areas. In living areas, the relevant standards and guidelines for interference emissions must be adhered to, and the devices must be installed in housings or control boxes with suitable attenuation of shielding.

2.2 Staff qualification

All operations involving Beckhoff software and hardware may only be carried out by qualified personnel with knowledge of control and automation engineering. The qualified personnel must have knowledge of the administration of the Embedded PC and the associated network.

All interventions must be carried out with knowledge of control programming, and the qualified personnel must be familiar with the current standards and guidelines for the automation environment.

2.3 Safety instructions

The following safety instructions must be followed during installation and working with networks and the software.

Explosion protection

Device modification CX2900-0107 is mandatory for operation of the Embedded PC in potentially explosive atmospheres, zone 2/22. The device modification entails the modification and relocation of the device label and a factory-fitted retainer bracket for mechanically securing the connectors.

 WARNING	<p>Operation without device modification</p> <p>Without the CX2900-0107 device modification, the USB plug connectors may slip out of the USB ports due to vibration, which may trigger a deflagration or explosion.</p> <p>The Embedded PC must only be used with the device modification, and the USB plug connectors must be secured to the retainer brackets with cable ties.</p>
---	---

Tighten the screws of the DVI plug connector and, if present, also the screws of the fieldbus plug connectors, in order to prevent the plug connectors slipping out. Only use RJ45 connectors with an intact latch. Use cable ties to secure the USB plug connectors and RJ45 connectors to the retainer brackets.

The CXxxxx-N020 optional interface (audio interface) may not be used in potentially explosive atmospheres.

The Embedded PC must be installed in a housing, which ensures protection class IP54 for gas according to EN 60079-15. A housing with protection class IP54 is required for non-conductive dust. IP6X is required for conductive dust according to EN 60079-31.

Observe the temperature at the cable entry points into the housing. If the temperature during nominal operation is higher than 70 °C at the entry points or higher than 80 °C at the wire branching points, cables must be selected that are designed for these high temperatures and operation in potentially explosive atmospheres.

Maintain the prescribed ambient temperature during operation. The permissible ambient temperature lies within the range from 0 °C ... +60 °C.

Take measures to prevent the rated operating voltage exceeding 119 V through short-term interference voltages.

Switch off the power supply and ensure that no explosive atmosphere occurs when:

- Bus Terminals are connected or removed,
- the Embedded PC is wired or cables are connected,
- the front flap is opened,
- the CFast card, MicroSD card or battery is replaced.

Mounting

- Never work on live equipment. Always switch off the power supply for the device before installation, troubleshooting or maintenance. Protect the device against unintentional switching on.
- Observe the relevant accident prevention regulations for your machine (e.g. the BGV A 3, electrical systems and equipment).

- Ensure standard-compliant connection and avoid risks to personnel. Ensure that data and supply cables are laid in a standard-compliant manner and ensure correct pin assignment.
- Observe the relevant EMC guidelines for your application.
- Avoid polarity reversal of the data and supply cables, as this may cause damage to the equipment.
- The devices contain electronic components, which may be destroyed by electrostatic discharge when touched. Observe the safety precautions against electrostatic discharge according to DIN EN 61340-5-1/-3.

Working with networks

- Restrict access to all devices to an authorized circle of persons.
- Change the default passwords to reduce the risk of unauthorized access. Regularly change the passwords.
- Install the devices behind a firewall.
- Apply the IT security precautions according to IEC 62443, in order to limit access to and control of devices and networks.

Working with the software

- Use up-to-date security software. The safe function of the PC can be compromised by malicious software such as viruses or Trojans.
- The sensitivity of a PC against malicious software increases with the number of installed and active software.
- Uninstall or disable unnecessary software.

Further information about the safe handling of networks and software can be found in the Beckhoff Information System:

<http://infosys.beckhoff.de>

Document name
Documentation about IPC Security

3 Transport and storage

Transport

 Attention	<p>Short circuit due to moisture</p> <p>Moisture can form during transport in cold weather or in the event of large temperature fluctuations.</p> <p>Avoid moisture formation (condensation) in the Embedded PC, and leave it to adjust to room temperature slowly. If condensation has occurred, wait at least 12 hours before switching on the Embedded PC.</p>
---	--

Despite the robust design of the unit, the components are sensitive to strong vibrations and impacts. During transport the Embedded PC must be protected from

- mechanical stress and
- use the original packaging.

Table 1: Weight and dimensions.

	CX9020
Weight	approx. 590 g
Dimensions (W x H x D)	84 mm x 99 mm x 91 mm

Storage

- The battery should be removed if the Embedded PC is stored at temperatures above 60 °C. The battery should be stored separate from the Embedded PC in a dry environment at a temperature between 0 °C and 30 °C.
The preset date and time are lost if the battery is removed.
- Store the Embedded PC in the original packaging.

4 Product overview

The CX9020 Embedded PC is a full-fledged PC with the following basic configuration:

- two MicroSD card slots,
- two switched Gbit-Ethernet interfaces,
- four USB 2.0 interfaces,
- and a DVI-D interface

The operating system is Microsoft Windows Embedded Compact 7.

The Embedded PC features internal persistent data memory in the form of 128 kB NOVRAM. In the event of a power failure, important data are stored in the NOVRAM and are available again after a restart.

The CX9020 Embedded PC can be ordered ex factory with a 1-second UPS (CX9020-U900). The 1-second UPS enables up to 1 MB of persistent data to be saved to the MicroSD card in the event of a loss of power.

The basic CPU module can be ordered ex factory with an optional interface. The optional interface cannot be retrofitted.

Table 2: Available optional interfaces for the CX9020.

CX9020-xxxx	Optional interfaces
CX9020-N020	Audio interface, 3 x 3.5 mm jack plug, Line-In, Mic-In, Line-Out
CX9020-N030	RS232, D-sub connector, 9-pin.
CX9020-N031	RS422/RS485, D-sub socket, 9-pin.
CX9020-B110	EtherCAT slave, EtherCAT IN and OUT (2 x RJ45).
CX9020-M310	PROFIBUS master, D-sub socket, 9-pin.
CX9020-B310	PROFIBUS slave, D-sub socket, 9-pin.
CX9020-M510	CANopen master, D-sub connector, 9-pin.
CX9020-B510	CANopen slave, D-sub connector, 9-pin.
CX9020-M930	PROFINET RT, controller, Ethernet (2 x RJ-45).
CX9020-B930	PROFINET RT, device, Ethernet (2 x RJ-45 switch).
CX9020-B950	EtherNet/IP Slave interface, Ethernet (2 RJ45 switches)

Power supply terminal

The power supply terminal for the Embedded PC is located on the right-hand side. Bus Terminals (K-bus) or EtherCAT Terminals (E-bus) can be attached on the right-hand side of the power supply terminal. The power supply terminal automatically recognizes the respective bus system (K-bus or E-bus).

Software

In combination with the TwinCAT automation software the CX9020 Embedded PC becomes a powerful IEC 61131-3 PLC. Up to four virtual IEC 61131-CPU's can each be programmed with up to four tasks. All IEC 61131-3 languages can be used.

Functions for Motion Control are also available, such as simple point-to-point movements.

In addition to real-time execution of control tasks, the TwinCAT real-time kernel ensures that enough time remains for the user interface (HMI), to communicate with the real-time components via software interfaces such as ADS or OPC.

4.1 Structure of the CX9020 Embedded PC

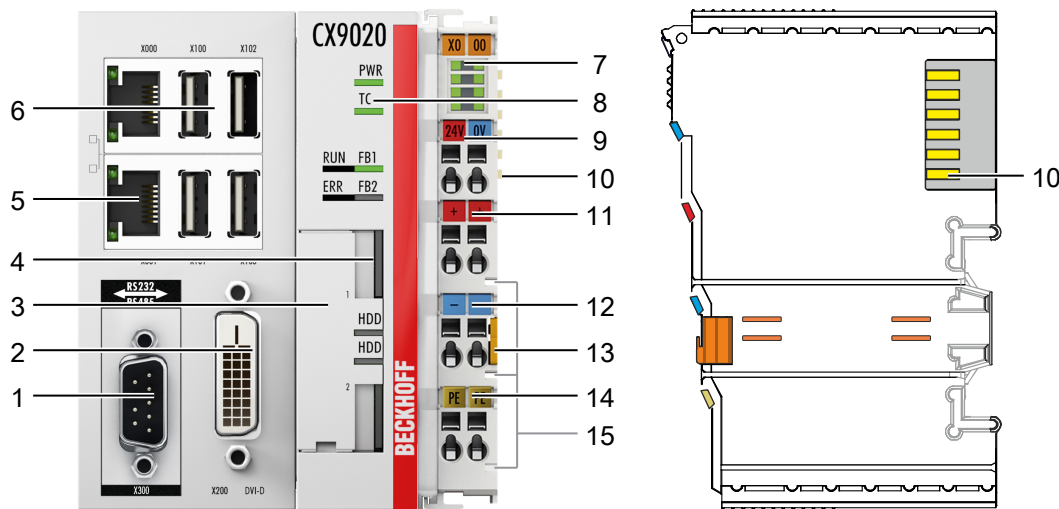

Fig. 1: Structure of the CX9020 Embedded PC.

Table 3: Legend for the configuration.

No.	Component	Description
1	Optional interface [▶ 20] (X300).	Space for interfaces such as RS232, EtherCAT, CANopen or others. The optional interface must be ordered ex factory and cannot be retrofitted retrospectively.
2	DVI-D interface [▶ 19] (X200).	Interface for a monitor or Panel.
3	Battery compartment [▶ 62] (under the front flap).	Power supply for the battery-backed clock for time and date.
4	2x MicroSD card slots. [▶ 30]	Slot for industrial MicroSD cards.
5	RJ45 Ethernet interfaces [▶ 18] (X000, X001).	Switched Ethernet interfaces. For connecting to local networks or the internet.
6	USB interfaces [▶ 17] (X100, X101, X102, X103).	Interfaces for peripherals such as mouse, keyboard or USB memory.
7	Diagnostic LEDs, power supply terminal. [▶ 57]	Diagnosis of the power supply for the Embedded PC and the Terminal Bus. Status of the E-bus and K-bus communication.
8	Diagnostic LEDs. [▶ 56]	Diagnostic LEDs for power supply, TwinCAT and the optional interface.
9	Spring-loaded terminals, +24 V and 0 V	Power supply for Embedded PC.
10	Terminal bus (K- or E-bus)	Interface for EtherCAT Terminals or Bus Terminals. Data exchange and supply.
11	Spring-loaded terminal, +24 V	Power supply for Bus Terminals via power contact.
12	Spring-loaded terminal, 0 V	Power supply for Bus Terminals via power contact.
13	Terminal release	Releases the power supply terminal and therefore the Embedded PC from the mounting rail.
14	Spring-loaded terminal, PE	Spring-loaded terminal for power contact PE.
15	Power contacts, +24 V, 0 V, PE	Power contacts for Bus Terminals.

4.2 Name plate

The CX9020 Embedded PC features a name plate on the left-hand side of the housing.

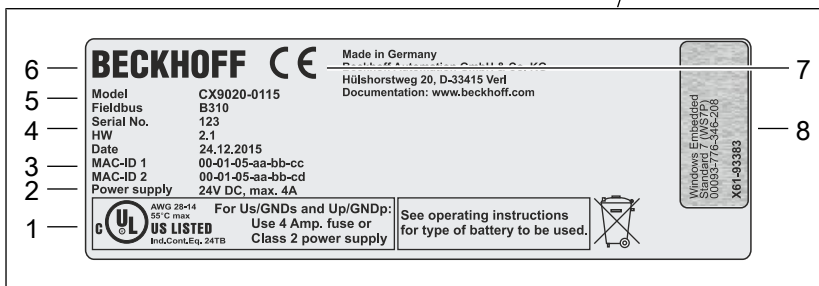
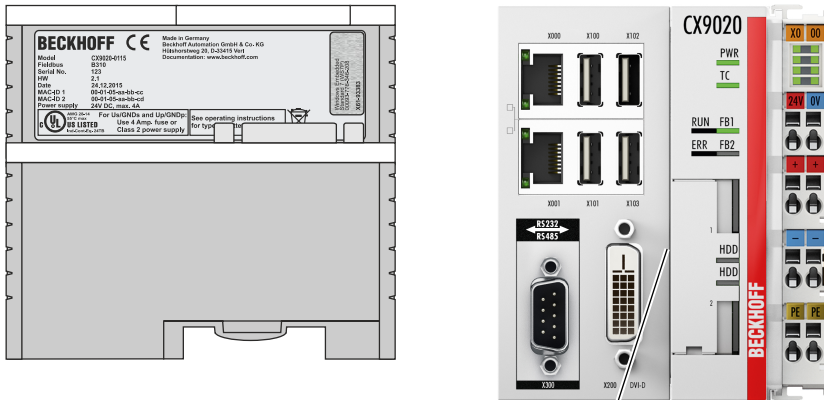

Fig. 2: CX9020 type plate.

Table 4: Legend for the name plate.

No.	Description
1	UL approval with prescribed information on power supply, fuse, temperature and cable cross-sections.
2	Information on the power supply unit. 24 V DC, 4 A max.
3	MAC addresses of the integrated Ethernet ports. By default, the host name is formed from "CX-" plus the last 3 bytes of the MAC address: Example: the host name CX-aabbcc is formed from the MAC address 00-01-05-aa-bb-cc.
4	Information on: <ul style="list-style-type: none"> • serial number, • hardware version • and date of manufacture.
5	Information on the model. The last four numerals relate to the configuration of Embedded PC.
6	Manufacturer information including address.
7	CE compliant.
8	Windows license sticker (optional).

4.3 Types

The CX9020 Embedded PC can be ordered with different software options. Use this overview in conjunction with the information on the name plate to ascertain the operating system and the TwinCAT version of the Embedded PC.

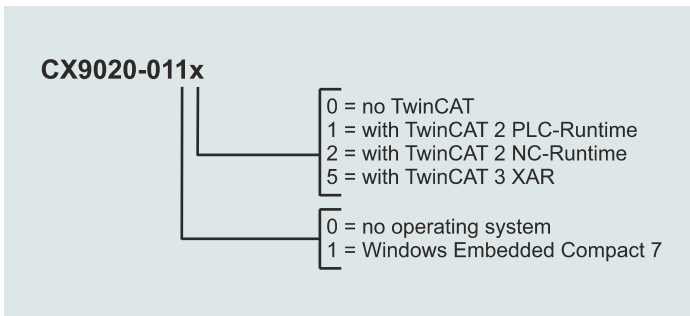

Fig. 3: Nomenclature for the CX9020 Embedded PC.

The CX9020 Embedded PC is available with the following software options:

Table 5: CX9020 (1 GHz 1 core), ordering information for software.

Module	no operating system	Windows Embedded Compact 7	no TwinCAT	TwinCAT 2 PLC runtime	TwinCAT 2 NC runtime	TwinCAT 3 XAR
CX9020-0100	X		X			
CX9020-0110		X	X	-	-	-
CX9020-0111		X	-	X	-	-
CX9020-0112		X	-	-	X	-
CX9020-0115		X	-	-	-	X

4.4 Architecture overview

The architecture of the CX9020 Embedded PC is described below.

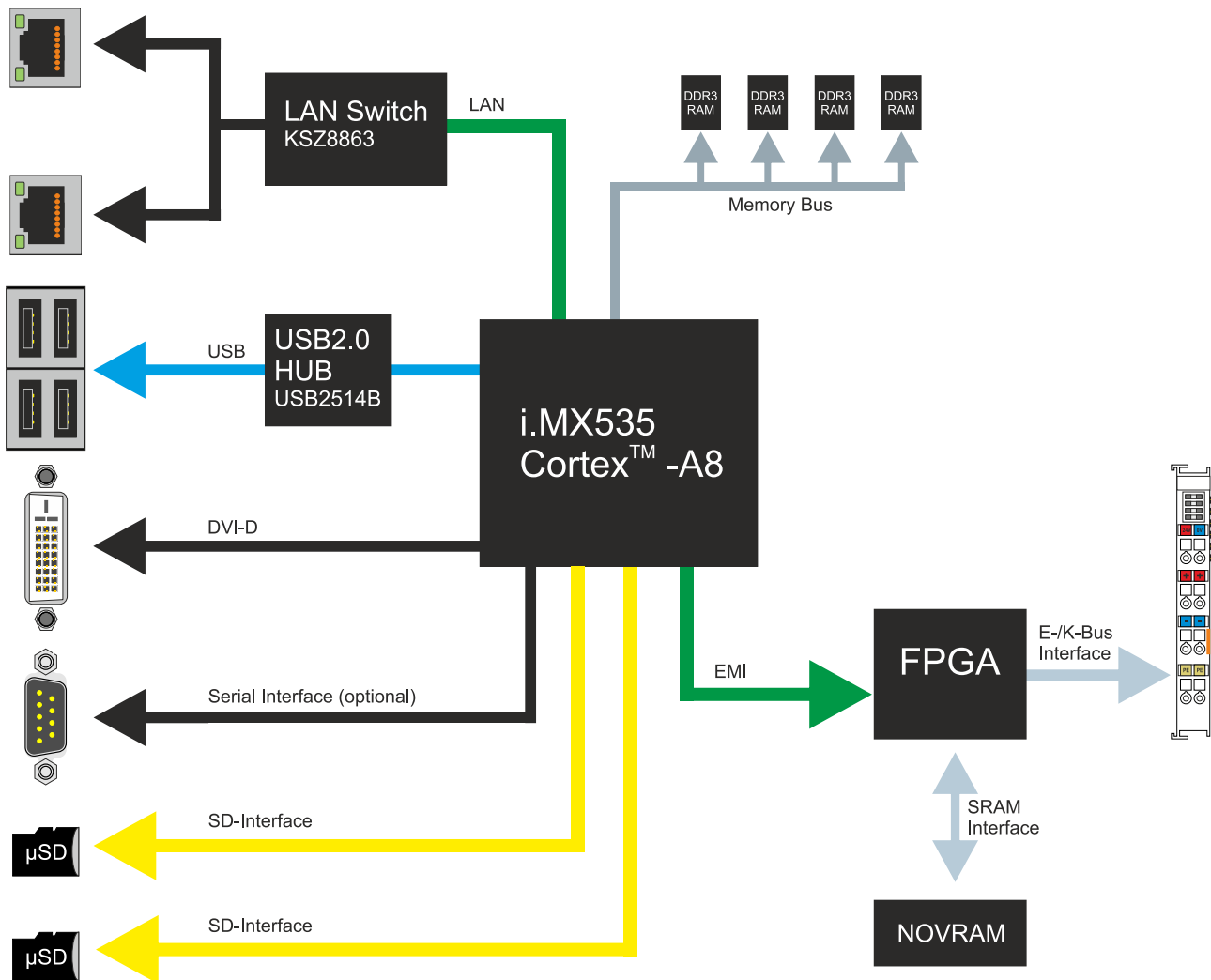

The CX9020 Embedded PC is based on the ARMv7-A microarchitecture developed by ARM®. The following CPU is used in the CX9020:

- i.MX535 Cortex™-A8

Details for the CPU can be read at ARM. The memory is connected directly to the CPU. The Embedded PC is available in one memory configuration: with 1 GB DDR3 RAM. The memory is not extendable. The CX9020 Embedded PC has two MicroSD card slots.

The CPU provides all required interfaces:

- 2x switched Ethernet RJ45 ports
- 4x USB 2.0
- DVI-D
- serial interface (CX9020-N03x)
- 1 EMI to FPGA for K-bus/E-bus and NOVRAM
- 2x MicroSD card slots

The interfaces USB, DVI, and LAN are standard interfaces. They can be used for operating devices that comply with the standard. Only digital signals can be transmitted via the DVI-D interface.

The RJ45 interfaces are fed to an internal switch and no additional Ethernet switches are required.

5 Description of the interfaces

5.1 USB (X100, X101, X102, X103)

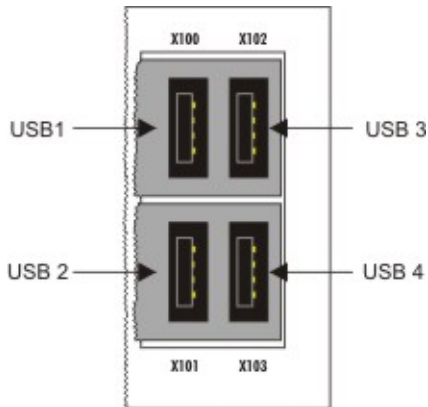

Fig. 4: USB interfaces (X100, X101, X102, X103).

The Embedded PC has four independent USB interfaces for connecting keyboards, mice, touchscreens and other input or data storage devices.

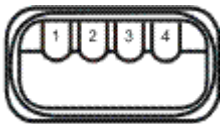

Fig. 5: USB interface, pin numbering.

Note the power consumption of the individual devices. Each interface is limited to 500 mA. The USB interface is of type A and corresponds to the USB 2.0 specification.

Table 6: USB interfaces (X100, X101, X102, X103), pin assignment.

Pin	Assignment	Typical assignment
1	VBUS	Red
2	D-	White
3	D+	Green
4	GND	Black
Shell	Shield	Drain Wire

5.2 Ethernet RJ45 (X000, X001)

Both Ethernet interfaces are switched and independent of each other. Please note the following points for an Embedded PC with switched Ethernet interfaces:

- The Embedded PC may not be connected to a local network if at the same time EtherCAT is operated via the second EtherNET interface. The EtherCAT telegrams (broadcast) disturb the local network, the consequence being that the Embedded PC can no longer be reached via a host PC.
- No additional switch is required for a line topology.

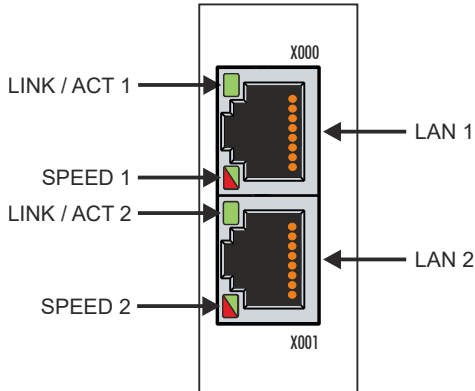

Fig. 6: Ethernet interface X000, X001.

Both Ethernet interfaces reach speeds of 10 / 100 Mbit. The LEDs on the left of the interfaces indicate the connection status. The upper LED (LINK/ACT) indicates whether the interface is connected to a network. If this is the case the LED is yellow. The LED flashes when data transfer on the interface is in progress.

The lower LED (SPEED) indicates the connection speed. The LED is not lit if the speed is 10 Mbit. At 100 Mbit the LED is green.



Fig. 7: Ethernet interface, pin numbering.

Table 7: Ethernet interface X000 and X001, pin assignment.

PIN	Signal	Description
1	TD +	Transmit +
2	TD -	Transmit -
3	RD +	Receive +
4	connected	not used
5		
6	RD -	Receive -
7	connected	not used
8		

5.3 DVI-D (X200)



Note

VGA adapter not compatible

The DVI interface does not implement VGA signals, therefore CRT-VGA monitors cannot be connected to the Embedded PC.

A DVI-D to VGA adapter cannot be used

The DVI-D interface transfers digital data and is suitable for connecting a digital display. The resolution at the display or the Beckhoff Control Panel depends on the distance from the display device. The maximum distance is 5 m. Beckhoff offers various Panels with an integrated "DVI extension". These make a cable length of up to 50 meters possible.

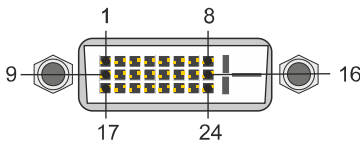

Fig. 8: DVI-D interface X200.

Table 8: DVI-D interface X200, pin assignment.

Pin	Assignment	Pin	Assignment	Pin	Assignment
1	TMDS Data 2-	9	TMDS Data 1-	17	TMDS Data 0-
2	TMDS Data 2+	10	TMDS Data 1+	18	TMDS Data 0+
3	TMDS Data 2/4 Shield	11	TMDS Data 1/3 Shield	19	TMDS Data 0/5 Shield
4	not connected	12	not connected	20	not connected
5	not connected	13	not connected	21	not connected
6	DDC Clock	14	+ 5V Power	22	TMDS Clock Shield
7	DDC Data	15	Ground (+5V, Analog H/V Sync)	23	TMDS Clock +
8	Analog Vertical Sync	16	Hot Plug Detect	24	TMDS Clock -

Table 9: DVI-D interface X200, resolution at the monitor.

Resolution in pixels	Distance of the interface from the monitor
1920 x 1200	5 m
1920 x 1080	5 m
1600 x 1200	5 m
1280 x 1024	5 m
1024 x 768	5 m
800 x 600	5 m
640 x 480	5 m

The Embedded PC also supports higher resolutions, based on the DVI standard. A maximum resolution of 2560 x 1440 pixels can be set on the Embedded PC. Whether this resolution is achieved depends on the monitor, the cable quality and the cable length.

5.4 Optional interfaces

5.4.1 Audio interface (N020)

Two inputs are available: "LINE IN" (X300) and "MIC IN" (X301). The "LINE OUT" interface (X302) is intended for audio signal output. The 3.5 mm sockets are designed for jack plugs. It can also be used for connecting headphones with a maximum output of 200 mW.

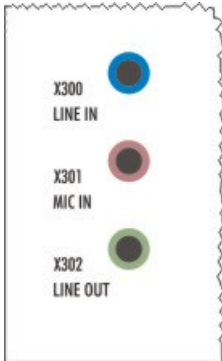

Fig. 9: Audio interface X300, X301, X302.

The audio interfaces are accessed via the operating system.

The audio interface operates in stereo mode as standard, using stereo outputs/inputs and a single-channel input for the microphone. The inputs should be connected as indicated.

Line In / Line Out jack plugs

The left channel is transferred via the tip of the jack plug, the right channel via the first ring. The remainder of the sleeve is used for earthing.

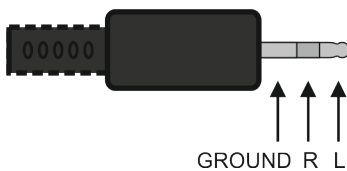

Fig. 10: Line In / Line Out X300, X302 jack plugs.

Table 10: Line In /Line Out jack plugs, pin assignment.

Signal	Description
L	Left channel
R	Right channel
Ground	Ground

Mic In jack plug

The only existing channel is transferred via the tip, the remainder of the sleeve is used for earthing.

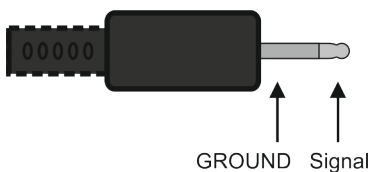

Fig. 11: Mic In X301 jack plug.

5.4.2 RS232 (N030)

The optional N030 interface provides an RS232 interface (X300). The RS232 interface is implemented on a 9-pin D-sub connector.

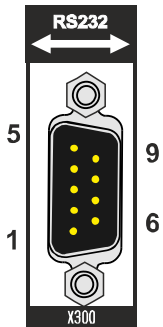

Fig. 12: RS232 interface X300 with pin numbering.

The maximum baud rate on both channels is 115 kbit. The interface parameters are set via the operating system or from the PLC program.

Table 11: RS232 interface X300, pin assignment.

PIN	Signal	Type	Description
1	DCD	Signal in	Data Carrier Detected
2	RxD	Signal in	Receive Data
3	TxD	Signal out	Transmit Data
4	DTR	Signal out	Data Terminal Ready
5	GND	Ground	Ground
6	DSR	Signal in	Dataset Ready
7	RTS	Signal out	Request to Send
8	CTS	Signal in	Clear to Send
9	RI	Signal in	Ring Indicator

5.4.3 RS422/RS485 (N031)

The optional N031 interface provides an RS422 or RS485 interface (X300). The interface is implemented on a 9-pin D-sub connector.

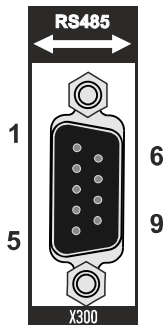

Fig. 13: RS485 interface X300 with pin numbering.

The maximum baud rate on both channels is 115 kbit. The interface parameters are set via the operating system or from the PLC program.

Table 12: RS422/485 interface, pin assignment.

PIN	Signal	Type	Description
2	TxD+	Data-Out +	Transmit 422
3	RxD+	Data-In +	Receive 422
5	GND	Ground	Ground
6	VCC	VCC	+5 V
7	TxD-	Data-Out -	Transmit 422
8	RxD-	Data-In -	Receive 422

For RS485 pins 2 and 3 (data +) must be connected, and pins 7 and 8 (data -).

By default the interface is parameterized as follows on delivery:

Table 13: Default setting, RS485 without echo with end point (terminated).

Function	Status
Echo on	off
Echo off	on
Auto send on	on
Always send on	off
Auto receive on	on
Always receive on	off
Term on	on
Term on	On

Other configurations for the RS485 interface

Other configurations for the RS485 interface can be ordered ex factory. The following options are available:

- N031-0001 RS485 with echo, end point (terminated).
- N031-0002 RS485 without echo, stub (without termination).
- N031-0003 RS485 with echo, stub (without termination).
- N031-0004 RS422 full duplex end point (terminated).

An RS485 interface cannot be configured retrospectively and must always be ordered ex factory as required.

5.4.4 EtherCAT slave (B110)

The latest generation of Embedded PCs can be ordered ex factory with an EtherCAT slave interface (B110). On the devices the optional B110 interface is referred to as X300.

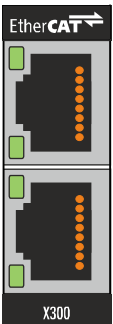

Fig. 14: EtherCAT slave interface X300.

The incoming EtherCAT signal is connected to the upper LAN interface. The lower LAN interface relays the signal to other EtherCAT slave devices.



Fig. 15: EtherCAT slave LAN interface, pin numbering.

Table 14: EtherCAT slave interface X300, pin assignment.

PIN	Signal	Description
1	TD +	Transmit +
2	TD -	Transmit -
3	RD +	Receive +
4	connected	reserved
5		
6	RD -	Receive -
7	connected	reserved
8		

For the optional EtherCAT slave interface (B110), documentation with further information is available for download from the Beckhoff website:

<https://www.beckhoff.de/german/download/epc.htm?id=71003127100362>

Document name
CXxxx0-B110 optional interface EtherCAT slave.

5.4.5 PROFIBUS (x310)

Pin 6 transfers $5 V_{DC}$, pin 5 transfers GND for the active termination resistor. These must never be used for other functions, as this can lead to destruction of the device.

Pins 3 and 8 transfer the PROFIBUS signals. These must never be swapped over, as this will prevent communication.

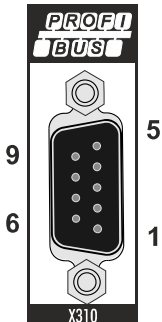

Fig. 16: PROFIBUS interface X310 with pin numbering.

The Profibus bus line is connected via a 9-pin D sub with the following pin assignment:

Table 15: PROFIBUS interface X310, pin assignment.

Pin	Assignment
1	Shielding
2	not used
3	RxD/TxD-P
4	not used
5	GND
6	+5 V_{DC}
7	not used
8	RxD/TxD-N
9	not used

Table 16: Wire colors of the PROFIBUS line.

PROFIBUS line	D sub
B red	Pin 3
A green	Pin 8

For the optional PROFIBUS interface (x310), documentation with further information is available for download from the Beckhoff website:

<https://www.beckhoff.de/german/download/epc.htm?id=71003127100362>

Document name
CXxxx0-x310 optional Profibus interface.

5.4.6 CANopen (x510)

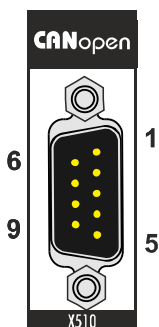

Fig. 17: CANopen interface X510 with pin numbering.

The CAN bus line is connected via a 9-pin D-sub socket with the following configuration:

Table 17: CANopen interface X510, pin assignment.

Pin	Assignment
1	not used
2	CAN low (CAN-)
3	CAN ground (internally connected to pin 6)
4	not used
5	Shield
6	CAN ground (internally connected to pin 3)
7	CAN high (CAN+)
8	not used
9	not used

For the optional CANopen interface (x510), documentation with further information is available for download from the Beckhoff website:

<https://www.beckhoff.de/german/download/epc.htm?id=71003127100362>

Document name
CXxxx0-x510 optional CANopen interface.

5.4.7 PROFINET RT (x930)

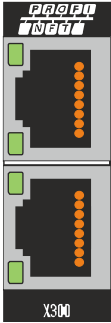

Fig. 18: PROFINET RT interface X300.



Fig. 19: PROFINET RT LAN interface, pin numbering.

Table 18: PROFINET RT interface, pin assignment.

PIN	Signal	Description
1	TD +	Transmit +
2	TD -	Transmit -
3	RD +	Receive +
4	connected	reserved
5		
6	RD -	Receive -
7	connected	reserved
8		

6 Commissioning

6.1 Assembly

6.1.1 Note the permissible installation positions

 Note	<p>Increased heat generation</p> <p>The Embedded PC may overheat if the installation position is incorrect or the minimum distances are not adhered to.</p> <p>The Embedded PC may only be operated at ambient temperatures of up to 60 °C. Ensure adequate ventilation. Select a horizontal installation position. Leave at least 30 mm clearance above and below the Embedded PC.</p>
--	--

Install the Embedded PC horizontally in the control cabinet on a mounting rail, in order to ensure optimum heat dissipation.

Note the following specifications for the control cabinet:

- The Embedded PC should only be operated at ambient temperatures between -25 °C and 60 °C. Measure the temperature below the Embedded PC at a distance of 30 mm to the cooling fins, in order to determine the ambient temperature correctly.
- Adhere to the minimum distances of 30 mm above and below the Embedded PCs.
- Additional electrical equipment affects the heat generation in the control cabinet. Select a suitable control cabinet enclosure depending on the application, or ensure that excess heat is dissipated from the control cabinet.

Correct installation position

The Embedded PC must be installed horizontally on the mounting rail. Ventilation openings are located at the top and bottom of the housing. This ensures an optimum airflow through the Embedded PC in vertical direction. In addition, a minimum clearance of 30 mm above and below the Embedded PCs required, in order to ensure adequate ventilation.

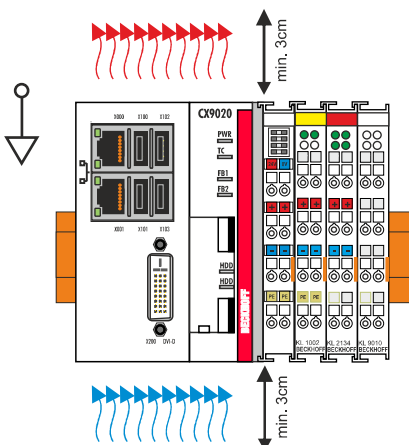

Fig. 20: CX9020 Embedded PC, permissible installation position.

If vibrations and impact occurs in the same direction as the mounting rail, the Embedded PC must be secured with an additional bracket, in order to prevent it slipping.

Incorrect installation positions

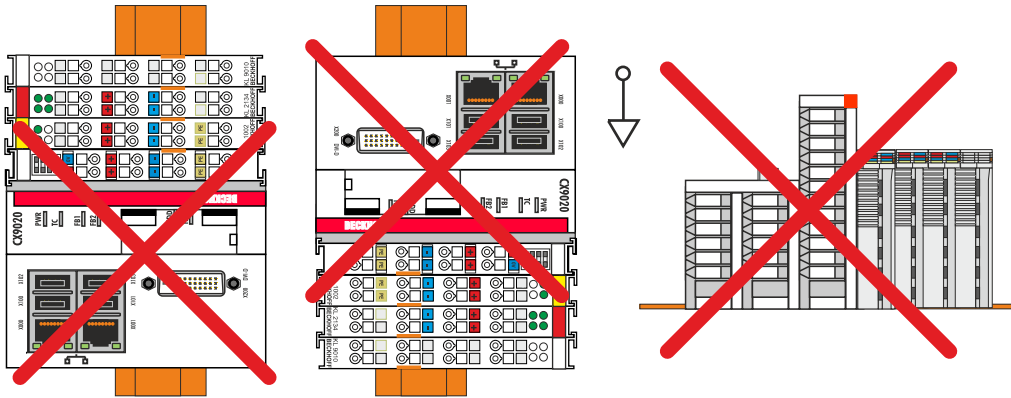

Fig. 21: CX9020 Embedded PC, invalid installation positions.

6.1.2 Attaching on mounting rail

The housing is designed such that the Embedded PC can be pushed against the mounting rail and latched onto it.

Requirements:

- Mounting rail of type TS35/7.5 or TS35/15 according to DIN EN 60715.

Secure the Embedded PC on the mounting rail as follows:

1. Unlock the latches at the top and bottom.

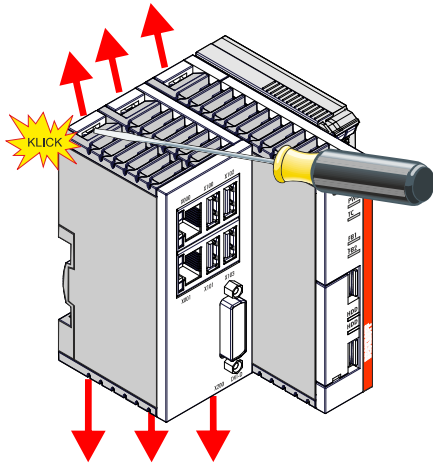

2. Place the Embedded PC at the front of the mounting rail. Slightly press the Embedded PC onto the mounting rail until a soft click can be heard and the Embedded PC has latched.

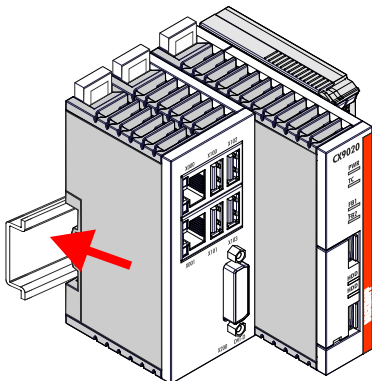

3. Then lock the latches again.

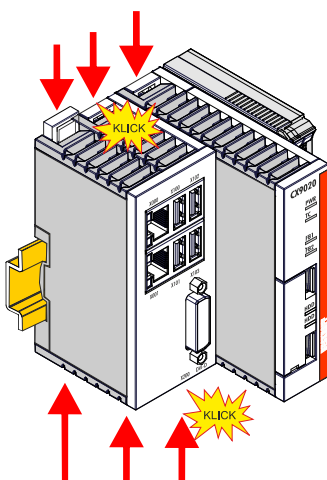

⇒ You have installed the Embedded PC successfully. Double-check the correct installation and latching of the Embedded PC on the mounting rail.

6.1.3 MicroSD card installation and removal



Note

Loss of data

MicroSD cards are subjected to heavy load during operation and have to withstand many write cycles and extreme ambient conditions. MicroSD cards from other manufacturer may fail, resulting in data loss.

Only use industrial MicroSD cards provided by Beckhoff.

The card for the operating system must be inserted in the upper slot (Slot 1). The lower slot (Slot 2) is intended for a further MicroSD card. Data or additional programs can be stored here.

The eject mechanism is based on the push/push principle. The installation and removal of the MicroSD cards is illustrated in the following.

Requirements:

- The Embedded PC must be switched off. The MicroSD cards may only be installed or removed when the Embedded PC is switched off.

Removing the MicroSD card

- Gently push the MicroSD card.
A soft click can be heard when the card is released.
- The card is lifted by approx. 2-3 mm from the housing. Pull out the card.

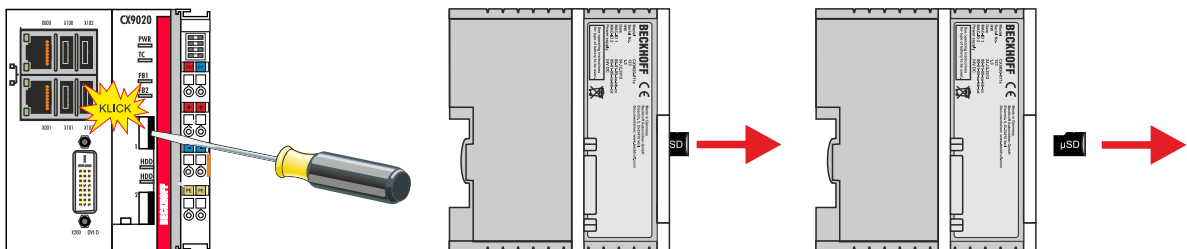

Installing a MicroSD card

- Push the MicroSD card into the Micro SD card slot.

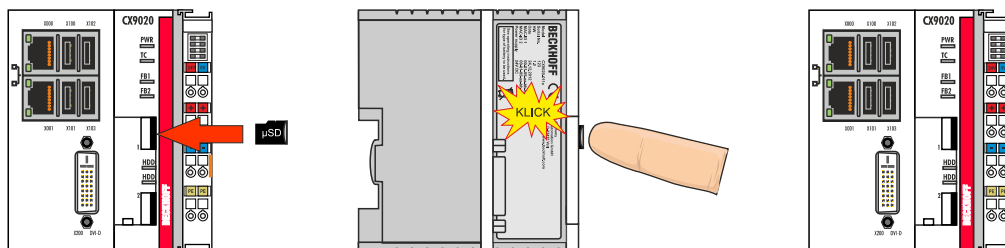

- A soft click can be heard when the MicroSD card engages.

⇒ The card is positioned correctly, if it is located approx. 1 mm lower than the front of the housing.

6.1.4 Installing passive EtherCAT Terminals



Note

Incorrectly installed passive EtherCAT Terminals

The E-bus signal between an Embedded PC and the EtherCAT Terminals can be impaired due to incorrectly installed passive EtherCAT Terminals.

Passive EtherCAT Terminals should not be installed directly on the power supply unit.

EtherCAT Terminals that do not take part in active data exchange are referred to as passive terminals. Passive EtherCAT Terminals have no process image and do not require current from the terminal bus (E-bus).

Passive EtherCAT Terminals (e.g. EL9195) can be detected in TwinCAT. In the tree structure the EtherCAT Terminal is displayed without process image, and the value in column "E-bus (mA)" does not change, compared to the preceding EtherCAT Terminal.

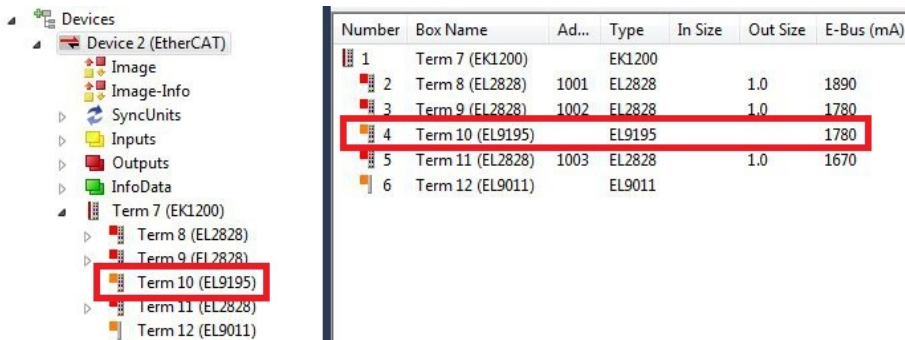

Fig. 22: Identifying a passive EtherCAT Terminal in TwinCAT.

The entry "Current consumption via E-Bus" in the technical data of an EtherCAT Terminal indicates whether a particular EtherCAT Terminal requires power from the terminal bus (E-bus).

The following diagram shows the permissible installation of a passive EtherCAT Terminal. The passive EtherCAT Terminal was not directly attached to the power supply unit.

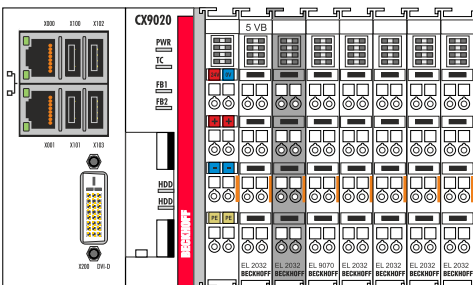

Fig. 23: Passive EtherCAT Terminals, permissible installation.

The following diagram shows the invalid installation of a passive EtherCAT Terminal.

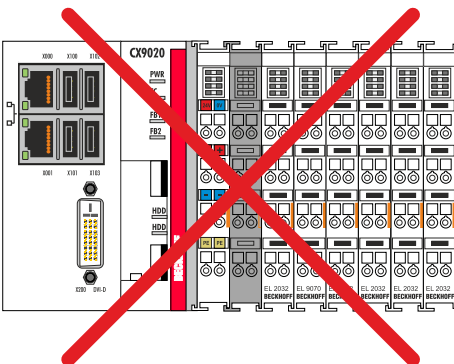

Fig. 24: Passive EtherCAT Terminals, invalid installation.

6.2 Connecting the power supply



Note

Damage to the Embedded PCs

The Embedded PCs may be damaged during wiring. The cables for the power supply should only be connected in de-energized state.

The power supply terminals require an external voltage source, which provides 24 V DC (-15% / +20%). The power supply terminal must provide 4 A at 24 V, in order to ensure the operation of the Embedded PCs in all situations.

A 4 A fuse should be used for the power supply of the Embedded PC.

The cabling of the Embedded PC in the control cabinet must be done in accordance with the standard EN 60204-1:2006 PELV = Protective Extra Low Voltage:

- The "PE" and "0 V" conductors of the voltage source for a basic CPU module must be on the same potential (connected in the control cabinet).
- Standard EN 60204-1:2006, section 6.4.1:b stipulates that one side of the circuit, or a point of the energy source for this circuit must be connected to the protective earth conductor system.

Connection example

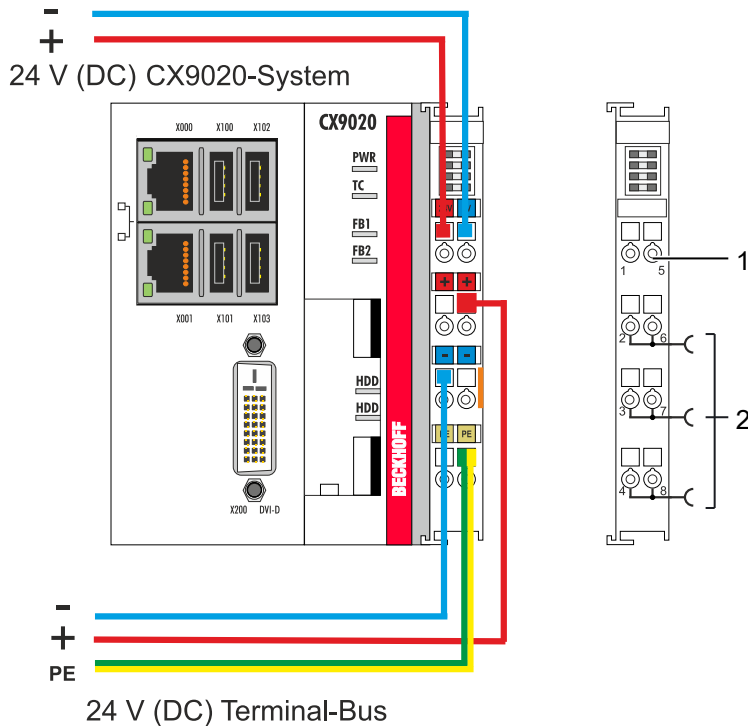



Table 19: Legend for the connection example

No.	Description
1	The upper spring-loaded terminals identified with "24 V" and "0 V" supply the Embedded PC and the Terminal Bus (data transfer via K- or E-bus).
2	The spring-loaded terminals identified as "+", "-", and "PE" supply the Bus Terminals via the power contacts and the sensors or actuators connected to the Bus Terminals.

	<p>Compliance with UL requirements:</p> <ul style="list-style-type: none"> • The Embedded PCs must not be connected to unlimited voltage sources. • Embedded PCs may only be supplied from a 24 V DC voltage source. The voltage source must be insulated and protected with a fuse of maximum 4 A (corresponding to UL248). • Or the power supply must originate from a voltage source that corresponds to NEC class 2. An NEC class 2 voltage source must not be connected in series or parallel with another NEC class 2 voltage source.
---	---

Opening and closing spring-loaded terminals:

The cables of an external voltage source are connected to the power supply unit with spring-loaded terminals. Connect the cables as follows:

Table 20: Required wire cross-sections and strip lengths

Wire cross section	0.5 ... 2.5 mm ²	AWG 20 .. AWG 14
Strip length	8 ... 9 mm	0.33 inch

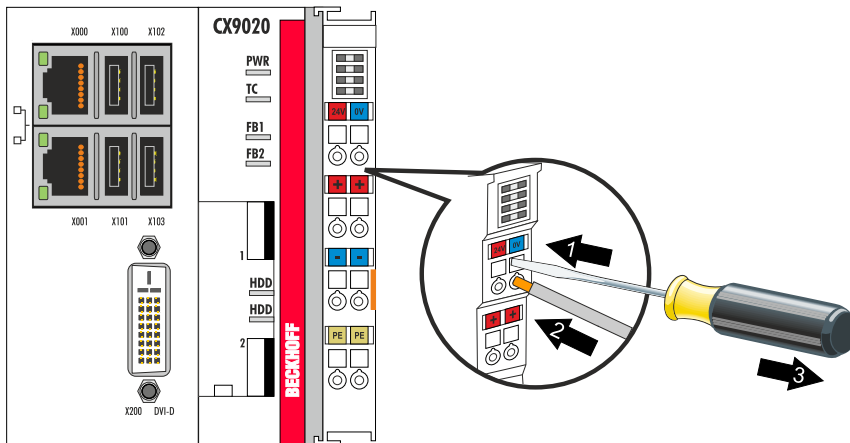



1. Open a spring-loaded terminal by slightly pushing with a screwdriver or a rod into the square opening above the terminal.
2. The wire can now be inserted into the round terminal opening without any force.
3. The terminal closes automatically when the pressure is released, holding the wire safely and permanently.

Power supply unit LEDs

The voltage sources have been connected to the power supply unit successfully when the two upper power supply terminal LEDs light up in green.

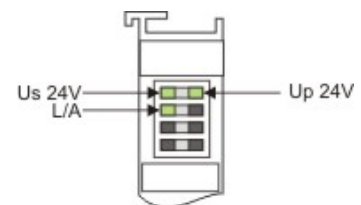
- The left LED (Us) indicates the supply of the basic CPU module and terminal bus.
- The red LED (Up) indicates the Bus Terminal supply via the power contacts.



 <p>Note</p>	<p>Interrupting / switching off the power supply</p> <p>To switch off the Embedded PC, do not disconnect the ground (0 V), because otherwise current may continue to flow via the shielding, depending on the device, and damage the Embedded PC or peripheral devices. Always disconnect the 24 V line. Devices connected to the Embedded PC, which have their own power supply (e.g. a Panel) must have the same potential for "PE" and "0 V" as the Embedded PC have (no potential difference).</p>
---	---

6.3 Switching on

Please ensure that the Embedded PC is fully configured before switching on the Embedded PC.

Switch on the Embedded PC as follows:

1. Ensure that all extension, system and fieldbus modules are connected correctly.
 2. Check whether the right CX2100 power supply unit and the right installation position were selected.
 3. Check whether the Embedded PC is mounted securely on the DIN rail and all required Bus Terminals are connected.
 4. Only then switch on the power supply for the power supply unit.
- ⇒ The Embedded PC starts automatically when the external power supply is switched on. The pre-installed operating system is started and all connected extension, system and fieldbus modules are configured.

6.4 Switching off



Note

Loss of data

If the Embedded PC is switched off during operation, data on the CFast card or other hard disks may be lost.

Do not disconnect the Embedded PC during operation.

Switch off the Embedded PC as follows:

1. Stop all running programs properly, e.g. the control software on the Embedded PC.
2. Shut down the operating system.
3. Do not switch off the external power supply until all other tasks have been completed, in order to switch off the Embedded PC.

7 Configuration

7.1 Windows Embedded Compact 7

7.1.1 Setting up the audio interface (N020)

Under Windows Embedded Compact 7, the Beckhoff CX configuration tool can be used for the audio settings.

Requirements:

- Embedded PC with audio interface.
- Windows Embedded Compact 7.

Proceed as follows:

1. Open the Beckhoff CX configuration tool under **Start > Control Panel > CX Configuration**. The Beckhoff CX configuration tool window opens.
2. Click on the **Miscellaneous** tab.

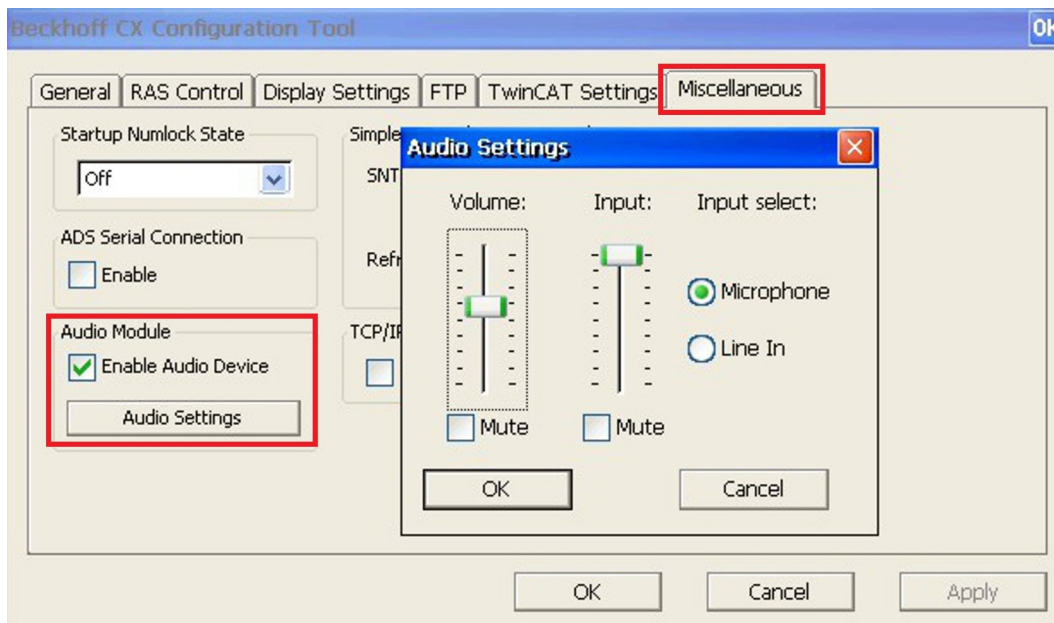

3. Tick the **Enable Audio Device** checkbox.
4. Click on **Audio Settings** and set the volume for input and output via the sliders.
5. Select the input source under **Input Select**. Only one input source can be active at any one time.

⇒ Confirm the settings with OK, once you have set up the audio interface.

7.2 Beckhoff Device Manager

7.2.1 Starting the Beckhoff Device Manager

The Beckhoff Device Manager can be used to configure an Embedded PC with a web browser via a host PC. The Beckhoff Device Manager can also be used for diagnostic purposes.

Requirements:

- The host PC and the Embedded PC must be in the same network, and the network firewall must allow access via port 80.
- The IP address or the host name of the Embedded PC must be known.

Access to the Beckhoff Device Manager is protected. The access data differ depending on the operating system.

Table 21: Access data for the Beckhoff Device Manager on delivery.

Operating system	Access data
Windows Embedded Standard 7 P, Windows 10 IoT Enterprise LTSB	User name: Administrator Password: 1
Windows Embedded Compact 7	User name: Webguest Password: 1

Start the Beckhoff Device Manager as follows:

1. On the host PC enter the IP address or the host name of the Embedded PC in the web browser, in order to start the Beckhoff Device Manager
 Example with IP address: **http://169.254.136.237/config**
 Example with host name: **http://CX-16C2B8/config**
2. In the authentication window enter the user name and the password. The start page appears:

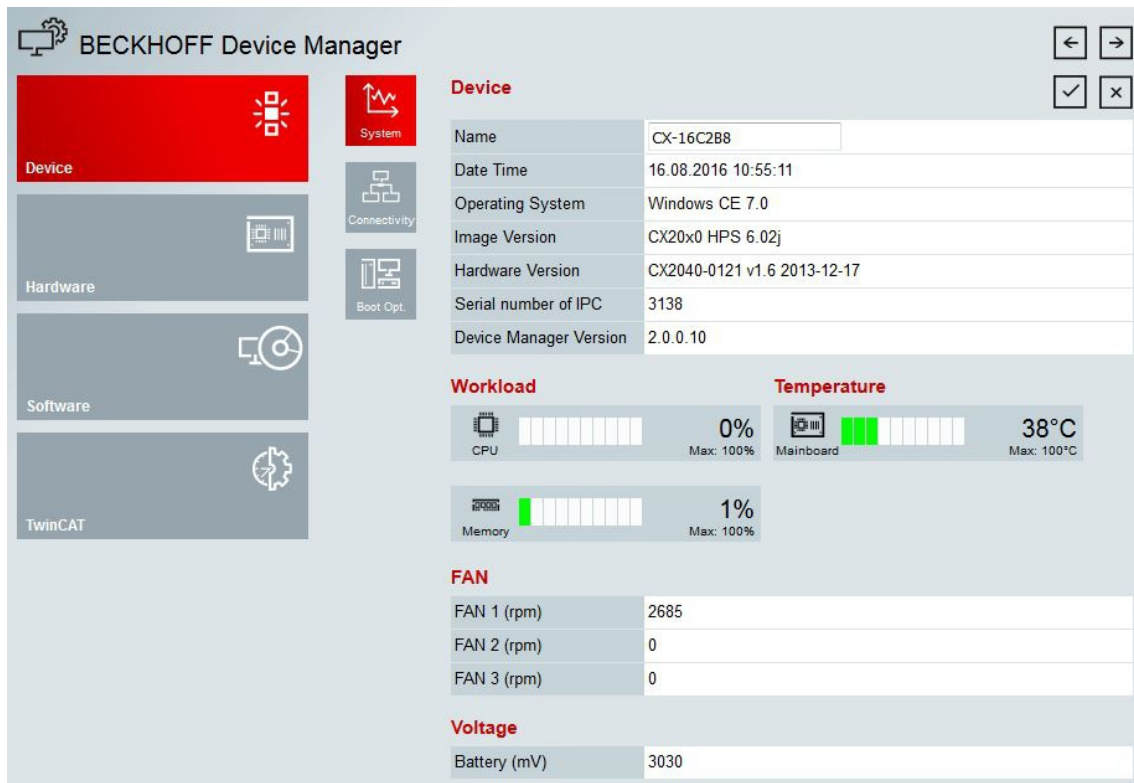

⇒ Continue to navigate in the menu and to configure the Embedded PC. Note that modifications only become active once they have been confirmed.

7.2.2 Enabling a remote display

In order to be able to access an Embedded PC with CE operating system via a remote display, a remote display has to be enabled first. Remote control of an Embedded PC with CE operating system from another PC requires an active remote display. The remote display is disabled as standard. This section illustrates how the remote display can be enabled with the Beckhoff device manager.

Requirements:

- The host PC and the Embedded PC must be in the same network, and the network firewall must allow access via port 80.
- The IP address or the host name of the Embedded PC must be known.

Enable the remote display as follows:

1. Enter the IP address or the host name of the Embedded PC in a web browser on the host PC.
 Example with IP address: **http://169.254.136.237/config**
 Example with host name: **http://CX-16C2B8/config**
2. In the authentication window enter the user name and the password for the Beckhoff Device Manager.
 The default settings are:
 User name: **Webguest**
 Password: **1**
3. In the menu under **Device** click on **Boot Opt.**

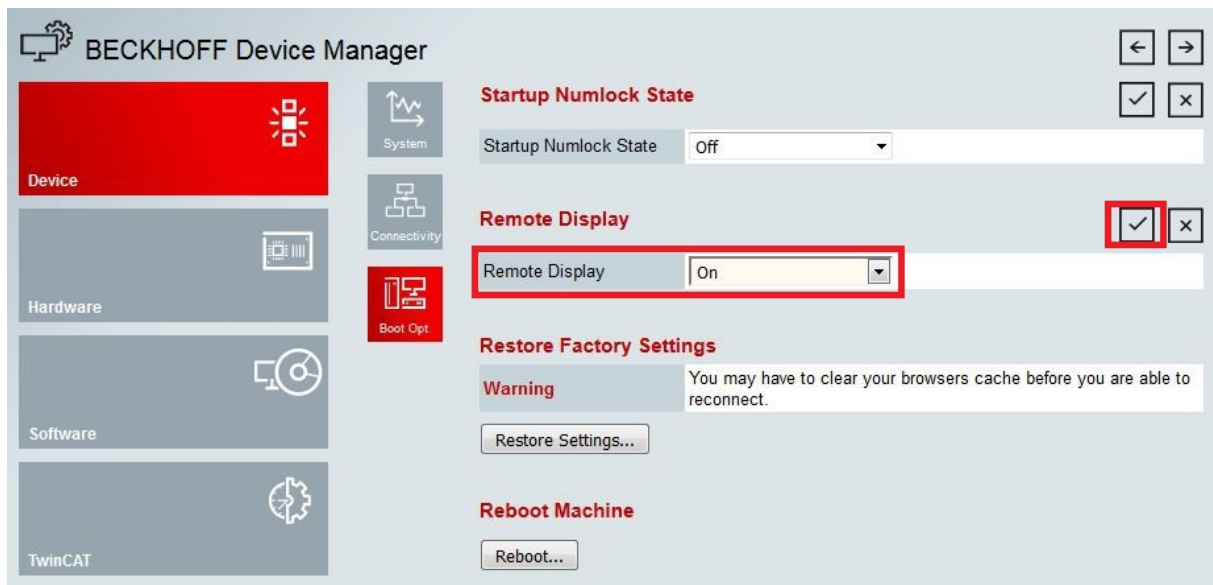

4. Under **Remote Display** select the option **On** and confirm the settings.
5. In the information window click **OK** to accept the settings.

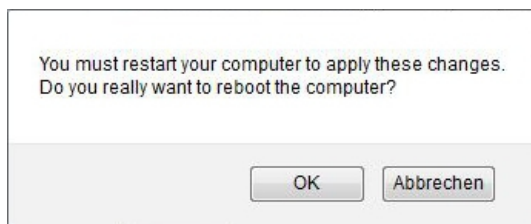

⇒ You have successfully activated the remote display on the Embedded PC. After a restart you can access your Embedded PC via remote display.

7.3 TwinCAT

7.3.1 Tree view

The Tree View chapter can be used as an example for creating a project without actual hardware. All devices and components of an Embedded PCs must be added manually in TwinCAT 3.

The smallest possible configuration of the CX9020 Embedded PC is created as follows in the tree view under TwinCAT 3:

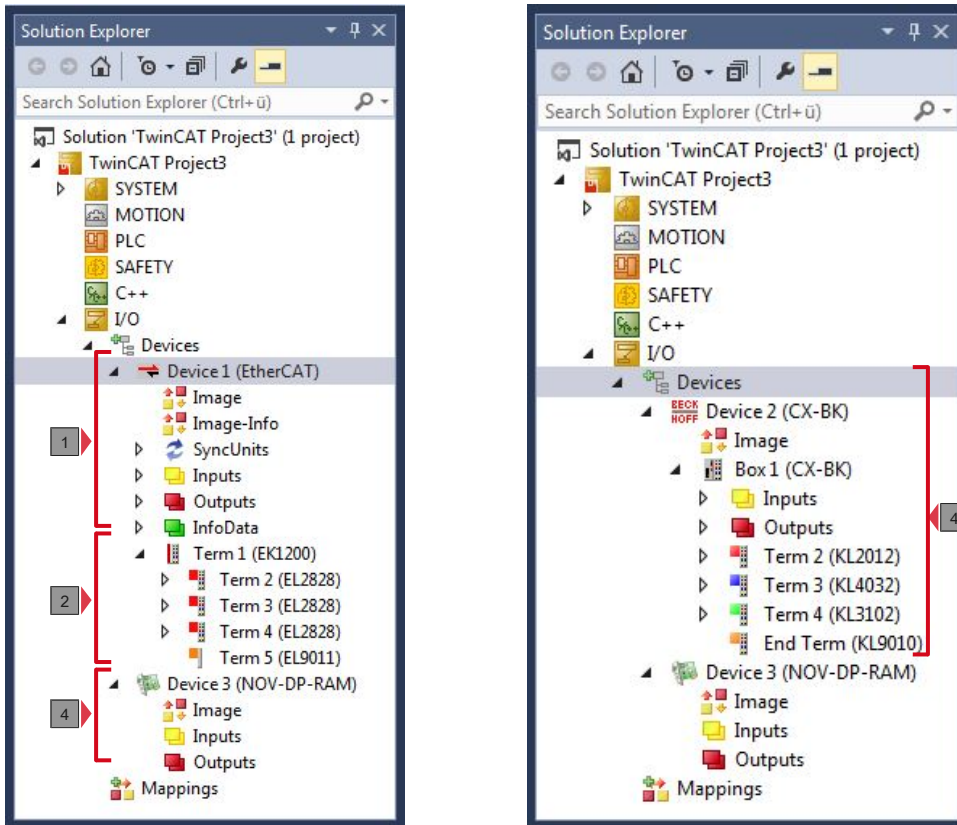

Fig. 25: CX9020 Embedded PC in the tree view of TwinCAT 3, with attached EtherCAT Terminals (left) or Bus Terminals (right).

The configuration in the tree view differs depending on whether EtherCAT Terminals or Bus Terminals are connected to the Embedded PC.

Table 22: Legend for the tree view.

No.	Description
1	The CX9020 Embedded PC with EtherCAT Terminals is added as EtherCAT master. Variables for diagnostic purposes are listed under inputs or outputs.
2	EtherCAT Terminals (E-bus) are displayed under the EK1200 Bus Coupler in the tree view.
3	The CX9020 features NOVRAM for storing up to 128 kB of data securely. At this point the NOVRAM handler is created, followed by configuration of the retain variables.
4	If Bus Terminals (K-bus) are used together with an Embedded PC, the Bus Coupler (CX-BK) is added together with the Bus Terminals.

7.3.2 Searching for target systems

Before you can work with the devices, you must connect your local computer to the target device. Then you can search for devices with the help of the IP address or the host name.

The local PC and the target devices must be connected to the same network or directly to each other via an Ethernet cable. In TwinCAT a search can be performed for all devices in this way and project planning subsequently carried out.

Prerequisites for this step:

- TwinCAT 3 must be in Config mode.
- IP address or host name of the device.

Search for the devices as follows:

1. In the menu at the top click on **File > New > Project** and create a new TwinCAT XAE project.
2. In the tree view on the left click on **SYSTEM**, and then **Choose Target**.



3. Click on **Search (Ethernet)**.

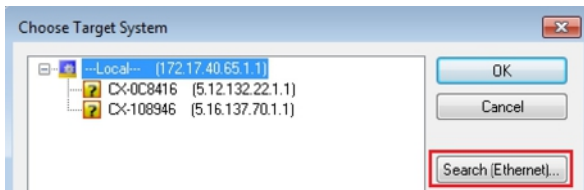

4. Type the host name or the IP address of the device into the **Enter Host Name / IP** box and press **[Enter]**.

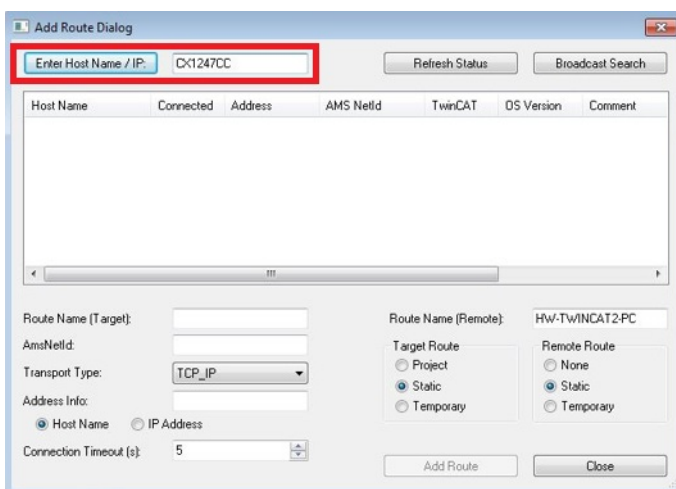

5. Mark the device found and click on **Add Route**.

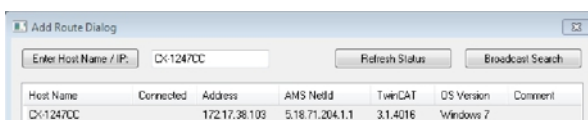

The Logon Information window appears.

Enter the user name and password for the CX in the **User Name** and **Password** fields and click **OK**.



The following information is set as standard in CX devices:

User name: Administrator **Password:** 1

6. If you do not wish to search for any further devices, click on **Close** to close the Add Route Dialog. The new device is displayed in the Choose Target System window.
7. Select the device you want to specify as target system and click **OK**.

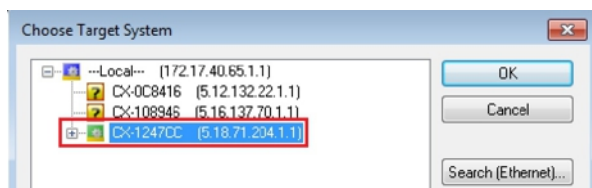

- ⇒ You have successfully searched for a device in TwinCAT and inserted the device as the target system. The new target system and the host name are displayed in the menu bar.



Using this procedure you can search for all available devices and also switch between the target systems at any time. Next, you can append the device to the tree view in TwinCAT.

7.3.3 Adding an Embedded PC

With this step you can add an Embedded PC in TwinCAT and then configure it.

Prerequisites for this step:

- A scanned and selected target device.

Add the Embedded PC as follows:

1. Start TwinCAT and open an empty project.
2. In the tree view on the left, right-click on **I/O Devices**.
3. In the context menu click on **Scan**.

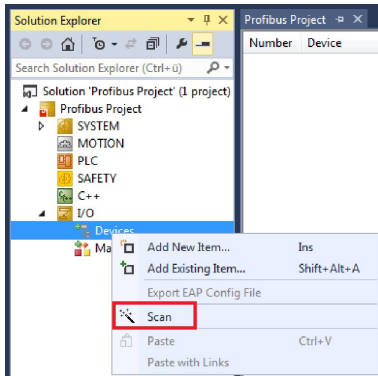

4. Select the devices you want to use and confirm the selection with **OK**. Only devices that are actual available are offered for selection.

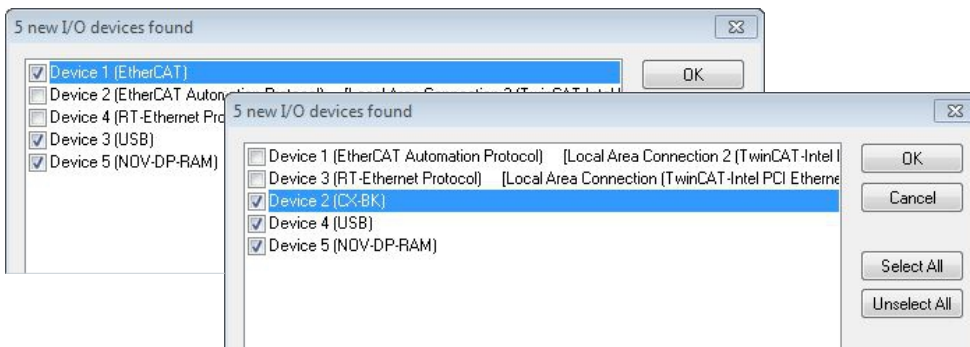

For Embedded PCs with connected Bus Terminals (K-bus) a Bus Coupler device (CX-BK) is displayed. For EtherCAT Terminals (E-bus) the EtherCAT coupler is added automatically.

5. Confirm the request with **Yes**, in order to look for boxes.
6. Confirm the request whether to enable FreeRun with **Yes**.

⇒ The Embedded PC was successfully added in TwinCAT and is displayed in the tree view with the inputs and outputs.

The [Tree view \[► 38\]](#) chapter illustrates how Embedded PCs with connected Bus or EtherCAT Terminals are displayed.

8 NOVRAM

The NOVRAM can be used to reliably save important variable values, such as production data or counter values, in the event of a power failure. The memory size of the NOVRAM is limited and only suitable for smaller data quantities up to 63 kB.

This chapter illustrates how the NOVRAM is

- used in TwinCAT 3 (see: [Use under TwinCAT 3](#) [▶ 43]).

Functioning

The NOVRAM (Non-Volatile Random Access Memory) is a special memory component that is used to reliably save important data. The NOVRAM consists of two sections, a volatile memory and a non-volatile memory.

TwinCAT only writes to the volatile section of the NOVRAM. In the event of a power failure, the data are automatically copied from the volatile memory into the non-volatile memory. The energy required for this process is supplied by a capacitor. As soon as the power supply is restored, the data are automatically copied back into the volatile memory, so that TwinCAT can continue to use them.

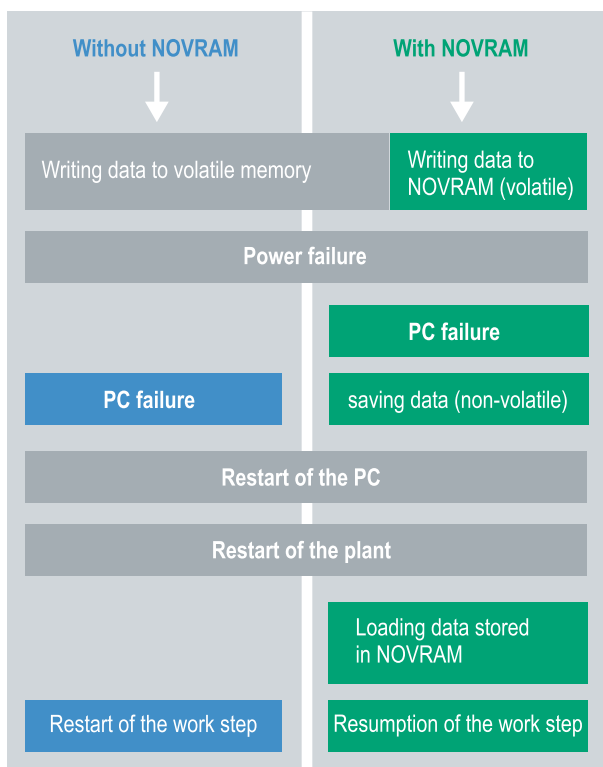

Fig. 26: Controller behavior with and without NOVRAM.

Memory size

The NOVRAM has a capacity of 128 kB. However, for reasons of data consistency, effectively less than 63 kB of data can be securely saved in the NOVRAM. The data are saved cyclically and alternately based on the dual buffer principle, in order to avoid the risk of data inconsistency.

Requirements

Development environment	Target platforms	Hardware	PLC libraries to include
TwinCAT 3.1 Build: 4020	PC or CX (x86, x64, ARM)	CX9020, CX20x0, CX20x2	Tc2_IoFunctions

8.1 Use under TwinCAT 3

Under TwinCAT 3 (from Build 4020) a delta algorithm is used to save data in the NOVRAM. The algorithm does not save all the variables in the NOVRAM. Instead, it searches for changes (delta function) compared to the previous cycle and only saves variables that have changed.

To use the delta algorithm, a Retain Handler must be created in TwinCAT 3, and the relevant variables must be declared in the PLC with the keyword VAR_RETAIN.

A new feature of this method is that no function blocks have to be used. The Retain Handler saves data in the NOVRAM in the event of a power failure and makes them available again once the power has been restored.

8.1.1 Creating a Retain Handler

This chapter describes how to create a Retain Handler in TwinCAT 3. The Retain Handler saves data in the NOVRAM and makes them available again. In other words, important variable values such as production data or counter values are retained during a restart or power failure.

Prerequisites for this step:

- TwinCAT 3.1 Build: 4020.
- A target device selected in TwinCAT.

Create the Retain Handler as follows:

1. Right-click on **Devices** in the tree view on the left-hand side.
2. In the context menu click on **Scan**.

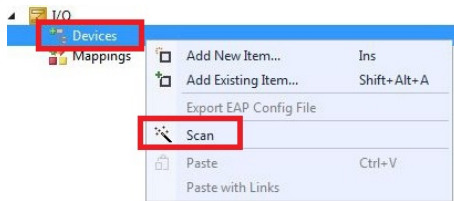

3. Select **Device (NOV-DP-RAM)** and confirm with **OK**.

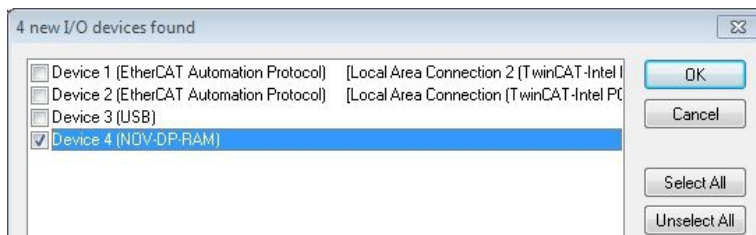

4. Click on **Yes** to search for boxes.

- Click on **Device (NOV-DP-RAM)** in the tree view on the left-hand side and then on the tab **Generic NOV-DP-RAM Device**.

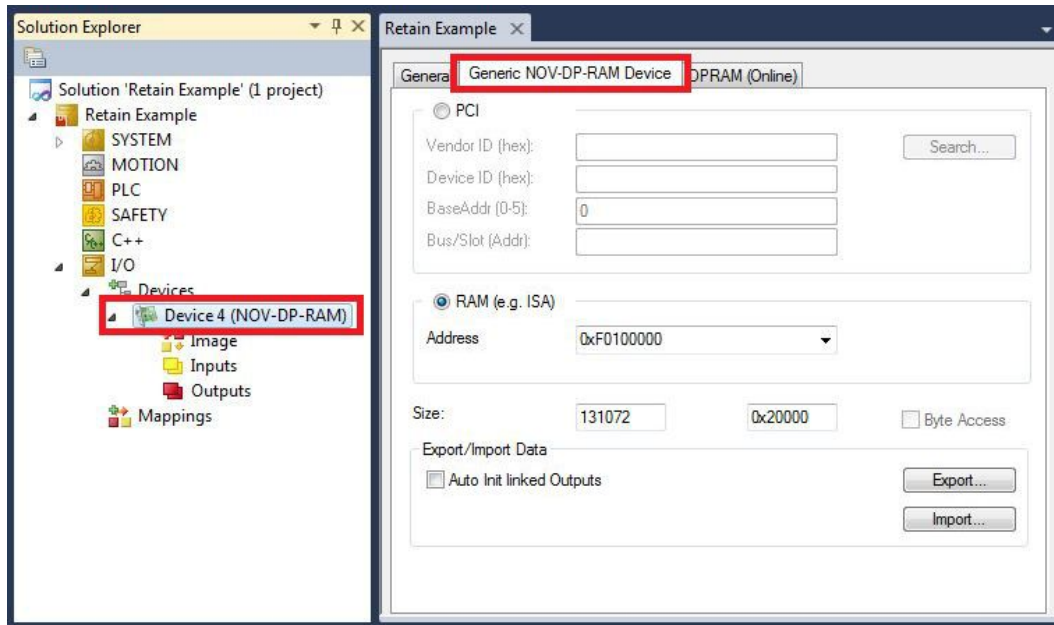

- Click on the option **RAM**.
- Right-click on **Device (NOV-DP-RAM)** in the tree view and then on **Add New Item**.

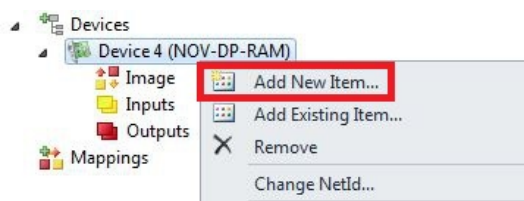

- Select the **Retain Handler** and click on **OK**.



⇒ You have successfully created a Retain Handler in TwinCAT.

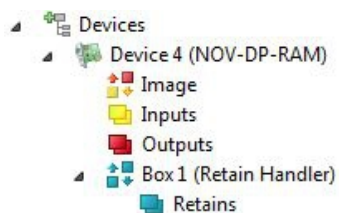

In the next step you can create retain variables in the PLC and link them with the Retain Handler.

8.1.2 Creating and linking variables

Once you have created a Retain Handler in TwinCAT, you can declare variables in the PLC and link them to the Retain Handler. The variables have to be identified in the PLC with the keyword VAR_RETAIN.

Prerequisite for this step:

- A PLC project created in TwinCAT.

Create variables as follows:

1. Create the variables in your PLC project in a VAR_RETAIN area.

```

1  PROGRAM MAIN
2
3  VAR_RETAIN
4      x      :UINT;
5      y      :UINT;
6      z      :UINT;
7  END_VAR
8
9  VAR
10
11     datain  AT%I*: REAL;
12     dataout AT%Q*: BYTE;
13
14 END_VAR
    
```

2. Click on **Build** in the toolbar at the top, then on **Build Solution**.

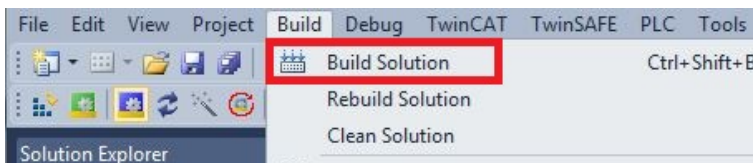

3. Click on **PLC Instance** in the tree view on the left and then on the tab **Data Area**.

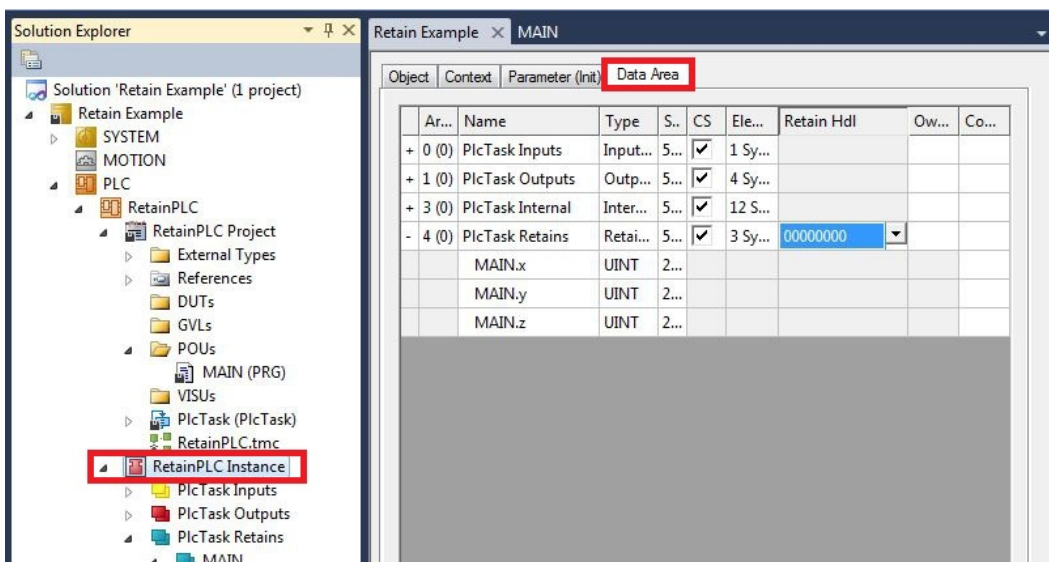

4. Under **Retain Hdl**, select the Retain Handler that you have created.

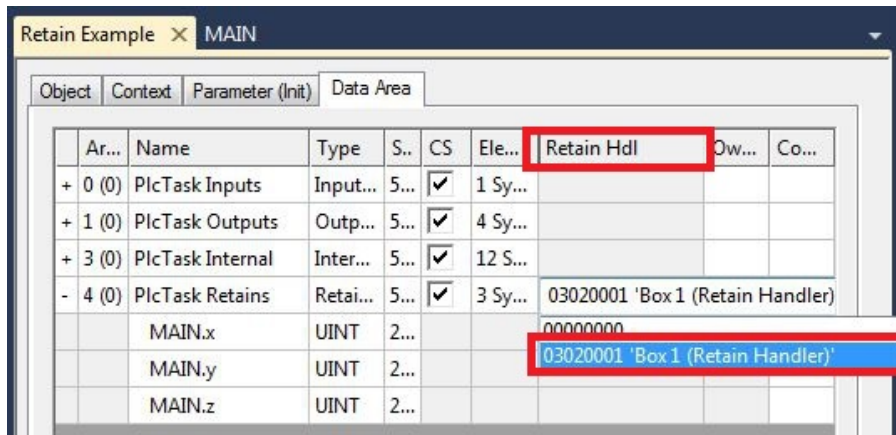

- ⇒ After selecting a Retain Handler as a target, the symbols in the tree view are linked and a mapping is created.

In the tree view the variables are created from the PLC under the Retain Handler and linked to the variables from the PLC instance.

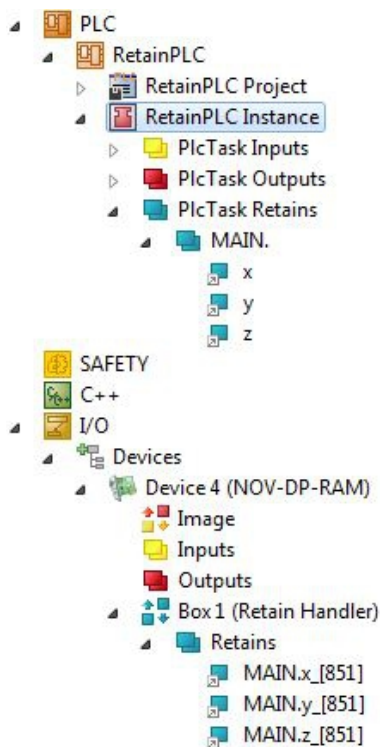

An existing link is displayed with an arrow symbol.

8.1.3 Note the write speed of the Retain Handler

The Retain Handler takes a certain amount of time to search for changes (delta function) in the variables and save them in the NOVRAM.

The following diagrams provide an overview of how long the Retain Handler needs to save a particular data quantity in the NOVRAM. Use the diagrams to select your task cycle time such that a particular data quantity is saved in the NOVRAM within the selected task cycle time.

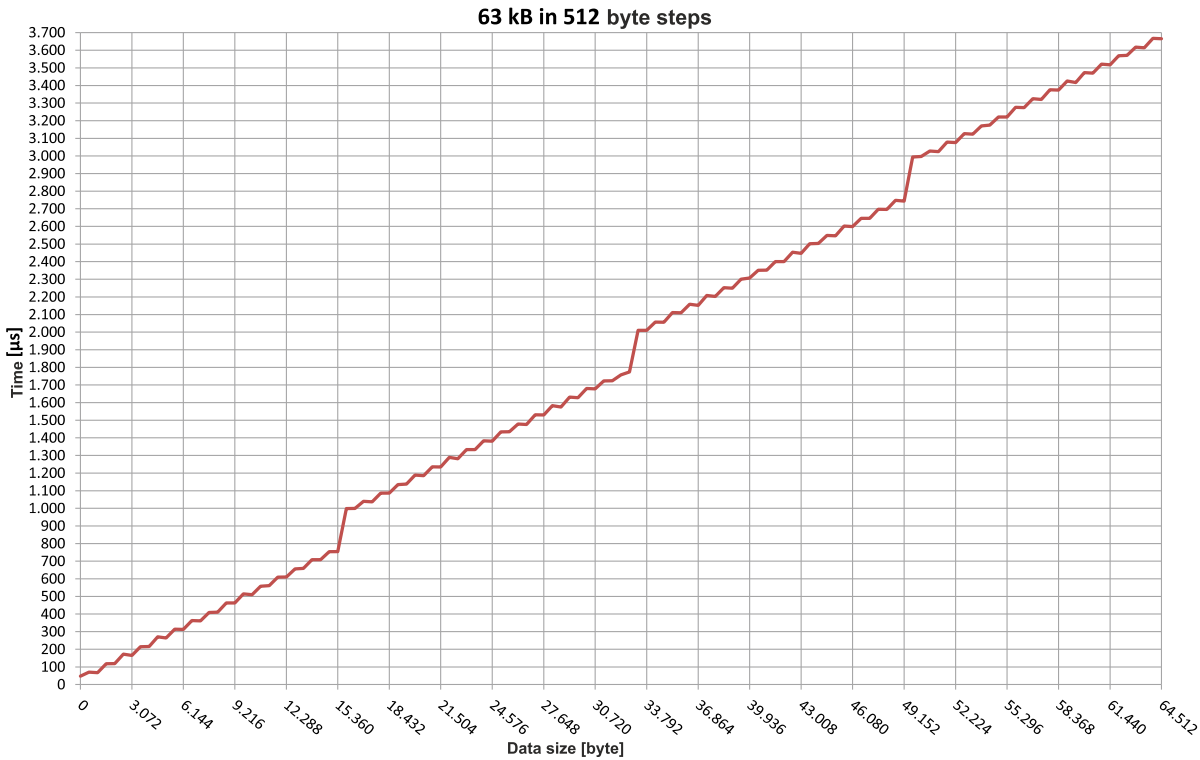

Fig. 27: Retain Handler write speed, up to 63 kB in 512 byte steps.

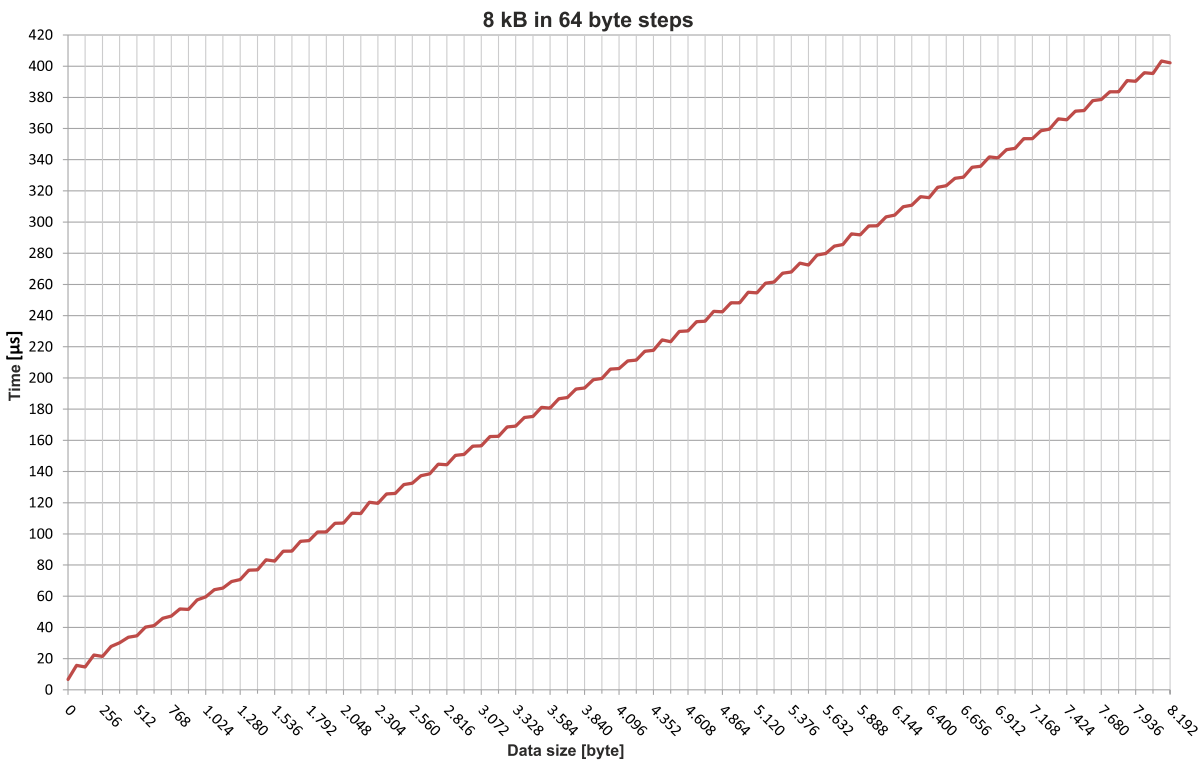

Fig. 28: Retain Handler write speed, up to 8 kB in 64 byte steps.

8.1.4 Deleting variables under the Retain Handler

If variables are deleted from the PLC, the link with the Retain Handler is cancelled. However, the variables continue to be shown under the Retain Handler and are not deleted automatically.

Under TwinCAT 3 the variables have to be deleted manually.

Prerequisites for this step:

- Variables declared with VAR_RETAIN were deleted from the PLC.

Delete the variables under the Retain Handler as follows:

1. The variable GVL_Retain.iNt [851] under the Retain Handler is to be deleted.

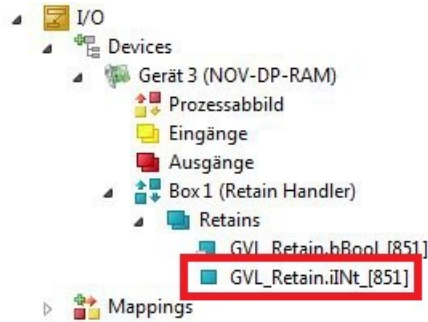

2. Right-click on the **Retain Handler** in the tree view on the left.
3. In the context menu click on **Optimize Retain Variables**.

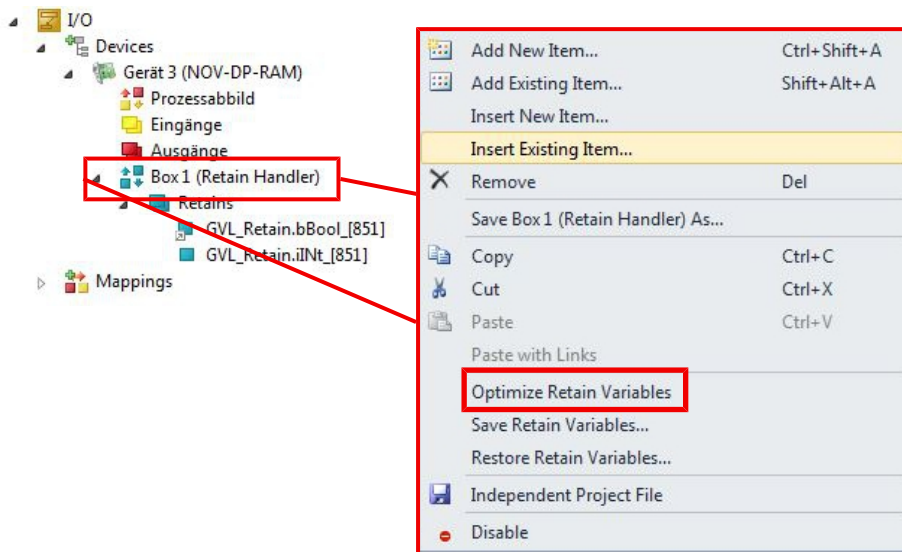

⇒ The variable under the Retain Handler is deleted.

9 1-second UPS (persistent data)



Note

Loss of data

The use of the 1-second UPS outside of the documented possibilities can lead to loss or corruption of data.
Use only TwinCAT to control the 1-second UPS and save only persistent data with a maximum size of 1 MB.

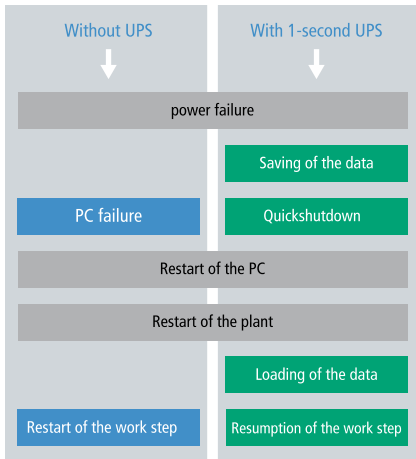

The 1-second UPS is an UltraCap capacitor that continues to supply the processor with power in the event of a power failure.

During this period persistent data can be saved, which are available on switching on again.

Since the 1-second UPS is designed for the entire service life, the holding time is considerably longer with new devices. The capacitors age over the course of time and the holding time decreases. Therefore a maximum of 1 MB persistent data can be reliably saved over the entire service life.

Do not save any other data and do not use any other applications to control the 1-second UPS.

Please note that the 1-second UPS does not supply power to the K-bus or the E-bus and that their data may already be invalid when the 1-second UPS is activated. Also, the fieldbus system (or Ethernet) may not work or not work properly once the 1-second UPS was activated.

Storage location and names of the files:

The persistent data are saved by default in the TwinCAT boot directory:

Development environment	File path	File name
TwinCAT 2	C:\TwinCAT\Boot\	TCPLC_T_x.wbp TCPLC_T_x.wb~ (Backup) The x in the file name stands for the number of the runtime system.
TwinCAT 3	C:\TwinCAT\3.1\Boot\	Port_85x.bootdata Port_85x.bootdata-old (Backup) The x in the file name stands for the number of the runtime system.

Configure the 1-second UPS as follows in order to save persistent data:

- For the CX9020 the 1-second UPS has to be ordered ex factory (CX9020-U900).
- Declare important data such as counter values in the PLC as VAR PERSISTENT. Then call the function block FB_S_UPS_CX9020_U900 cyclically in TwinCAT in order to control the 1-second UPS (see: [FB S UPS CX9020 U900 \[► 50\]](#)).
- Select the mode in the function block in order to specify what should happen in the case of a voltage failure. Specify, for example, whether persistent data are saved and a quick shutdown is executed (see: [Mode and status of the function block \[► 52\]](#))
- Subsequently you can check the validity of the variables and monitor whether the persistent variables are loaded without error (see: [Checking the validity of the variables \[► 53\]](#)).

Sample project:

https://infosys.beckhoff.com/content/1033/CX9020_HW/Resources/pro/2574947979.pro

Components	Version
TwinCAT on the development PC and on the control system	TwinCAT 2.11R3 Build 2047 (or higher) TwinCAT 3.1 Build 4018 (or higher)

9.1 FB_S_UPS_CX9020_U900



Note

Loss of data

The 1-second UPS switches the mainboard off as soon as the capacitors have discharged. If other applications or the PLC are keeping other data open or are writing to them, data may be corrupted or lost.

In the case of the CX9020 the function block FB_S_UPS_CX9020_U900 is used to control the 1-second UPS from the PLC. If possible, use the standard values of the FB_S_UPS_CX9020_U900 and call the function block cyclically in the PLC.

The function block has various modes that control the behavior of the Embedded PC when the 1-second UPS is triggered:

Table 23: Block modes.

Mode	Function
eSUPS_WrPersistData_Shutdown	Writing of the persistent data, followed by quick shutdown.
eSUPS_WrPersistData_NoShutdown	Only writing of the persistent data (no quick shutdown)
eSUPS_ImmediateShutdown	Quick shutdown only (no writing of persistent data)
eSUPS_CheckPowerStatus	Monitoring only (neither writing of the persistent data nor quick shutdown); data handling is entirely up to the user.

Regardless of the mode and therefore irrespective of whether data were saved or quick shutdown was performed, the 1-second UPS switches off the mainboard after discharging of the capacitors, even if the voltage has returned in the meantime.

No quick shutdown may be executed with Windows CE/WEC7, as otherwise Windows CE/WEC7 will restart immediately after the persistent data have been saved. This can lead to problems with the persistent data. Select exclusively the mode eSUPS_WrPersistData_NoShutdown with Windows CE/WEC7 in order to save persistent data without error.

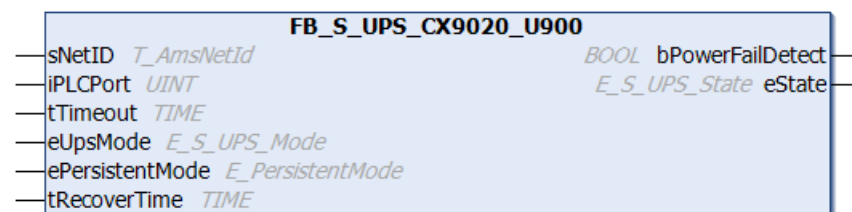

VAR_INPUT

```

VAR_INPUT
  sNetID      : T_AmsNetId:= ''; (* '' = local netid *)
  iPLCPort    : UINT := 0; (* PLC Runtime System for writing persistent data *)
  tTimeout    : TIME := DEFAULT_ADS_TIMEOUT; (* ADS Timeout *)
  eUpsMode    : E_S_UPS_Mode := eSUPS_WrPersistData_Shutdown; (* UPS mode (w/wo writing per-
  sistent data, w/wo shutdown) *)
  ePersistentMode : E_PersistentMode := SPDM_2PASS; (* mode for writing persistent data *)
  tRecoverTime : TIME := T#10s; (* ON time to recover from short power failure in mode eS-
  UPS_WrPersistData_NoShutdown/eSUPS_CheckPowerStatus *)
END_VAR

```

sNetID: AmsNetID of the controller. (Type: T_AmsNetId)

iPLCPort: Port number of the PLC runtime system.

tTimeout: Timeout for the execution of the quick shutdown.

eUpsMode: The eUpsMode defines whether persistent data are to be written and whether a quick shutdown is to be performed. Standard value is eSUPS_WrPersistData_Shutdown, i.e. with writing of the persistent data and then quick shutdown. (Type: [E_S_UPS_Mode](#) [► 52])

ePersistentMode: Mode for the writing of the persistent data. Standard value is SPDM_2PASS.

tRecoverTime: Time after which the UPS reverts to the PowerOK status in the case of UPS modes without shutdown. The tRecoverTime must be somewhat longer than the maximum holding time of the UPS, since the UPS switches off even when the voltage returns

VAR_OUTPUT

```
VAR_OUTPUT
    bPowerFailDetect : BOOL; (* TRUE while powerfailure is detected *)
    eState           : E_S_UPS_State; (* current ups state *)
END_VAR
```

bPowerFailDetect: TRUE during power failure. FALSE if the supply voltage is present.

eState: Internal state of the function block (type: [E_S_UPS_State](#) [► 52])

VAR_GLOBAL

```
VAR_GLOBAL
    eGlobalSupsState : E_S_UPS_State; (*current ups state*)
END_VAR
```

eGlobalSupsState: Internal state of the function block as global copy of VAR_OUTPUT

eState: For values see [E_S_UPS_State](#) [► 52].

Development environment	Target platform	Hardware	PLC libraries to include
TwinCAT v2.11 R3 B2246 TwinCAT v3.1 B4016	CX9020-U900	1-Second UPS	For TwinCAT 2: TcSUPS_CX9020_U900.lib For TwinCAT 3: Tc2_SUPS

9.2 Mode and status of the function block

E_S_UPS_Mode

With the mode selected in the function block you can specify what should happen in the case of a power failure.

```
eSUPS_WrPersistData_Shutdown: Writing of persistent data and then a QuickShutdown
eSUPS_WrPersistData_NoShutdown: Only writing of the persistent data (no QuickShutdown)
eSUPS_ImmediateShutdown: Only QuickShutdown (no writing of persistent data)
eSUPS_CheckPowerStatus: Only check status (neither writing of persistent data nor a QuickShutdown)
```

E_S_UPS_State

The internal state of the function block can be read with E_S_UPS_State.

```
eSUPS_PowerOK:
in all modes: Power supply is OK

eSUPS_PowerFailure:
in all modes: Power supply is faulty (only shown for one PLC cycle)

eSUPS_WritePersistentData:
in mode eSUPS_WrPersistData_Shutdown: Writing of persistent data is active
in mode eSUPS_WrPersistData_NoShutdown: Writing of persistent data is active

eSUPS_QuickShutdown:
in mode eSUPS_WrPersistData_Shutdown: QuickShutdown ist active
in Mode eSUPS_ImmediateShutdown: QuickShutdown is active

eSUPS_WaitForRecover:
in mode eSUPS_WrPersistData_NoShutdown: Wait for the reestablishment of the power supply
in mode eSUPS_CheckPowerStatus: Wait for the reestablishment of the power supply

eSUPS_WaitForPowerOFF:
in mode eSUPS_WrPersistData_Shutdown: Wait for switching off of the PC by the UPS
in mode eSUPS_ImmediateShutdown: Wait for switching off of the PC by the UPS
```

9.3 Checking the validity of the variables

For TwinCAT 2 the implicit structure `SystemInfoType.bootDataFlags` can be read in order to determine the validity of the persistent data (see: [SYSTEMINFOTYPE \[▶ 53\]](#)).

For TwinCAT 3 the implicit variables `PlcAppSystemInfo.BootDataLoaded` and `PlcAppSystemInfo.OldBootData` are available for determining the validity of the persistent data (see: [PlcAppSystemInfo \[▶ 55\]](#)).

9.3.1 SYSTEMINFOTYPE

```

TYPE SYSTEMINFOTYPE
STRUCT
runTimeNo :BYTE;
projectName :STRING(32);
numberOfTasks :BYTE;
onlineChangeCount :UINT;
bootDataFlags :BYTE;
systemStateFlags :WORD;
END_STRUCT
END_TYPE
    
```

runTimeNo: specifies the number of the runtime system (1..4).

projectName: project name as STRING.

numberOfTasks: number of tasks contained in the runtime system (max. 4).

onlineChangeCount: number of online changes since the last complete download.

bootDataFlags: State of the boot data (RETAIN and PERSISTENT) after loading. The upper four bits indicate the state of the persistent data, while the lower four bits indicate the state of the retain data.

Bit number	Description
0	RETAIN variables: LOADED (without error)
1	RETAIN variables: INVALID (the back-up copy was loaded, since no valid data was present)
2	RETAIN variables: REQUESTED (RETAIN variables should be loaded, a setting in TwinCAT System Control)
3	reserved
4	PERSISTENT variables: LOADED (without error)
5	PERSISTENT variables: INVALID (the back-up copy was loaded, since no valid data was present)
6	reserved
7	reserved

systemStateFlags : Reserved.

When shutting TwinCAT down the PERSISTENT and RETAIN data is written into two files on the hard disk. The path can be specified in TwinCAT System Control by means of the TwinCAT system properties (PLC tab). The standard setting is "<Drive>:\TwinCAT\Boot". The files all have a fixed name with fixed extensions:

File name	Description
TCPLC_P_x.wbp	Boot project (x = number of the run-time system)
TCPLC_S_x.wbp	Packed source code (x = number of the runtime system)
TCPLC_R_x.wbp	RETAIN variables (x = number of the runtime system)
TCPLC_T_x.wbp	PERSISTENT variables (x = number of the runtime system)
TCPLC_R_x.wb~	Backup copy of the RETAIN variables (x = number of the runtime system)
TCPLC_T_x.wb~	Backup copy of the PERSISTENT variables (x = number of the runtime system)

If the persistent or retain variables are not loaded, e.g. because they are invalid, the backup file is loaded by default. In that case bit 1 of the bootDataFlags (for the RETAIN variables) in the PLC and/or bit 5 (for the PERSISTENT variables) is set.

A registry setting can be used to determine whether the backup file is deleted or used. The backup file is used by default (setting 0). If the backup file is to be deleted, the value of "ClearInvalidRetainData" or "ClearInvalidPersistentData" must be set to 1 in the registry under:

```
[HKEY_LOCAL_MACHINE\SOFTWARE\Beckhoff\TwinCAT\Plc]
"ClearInvalidRetainData"=dword:00000000
"ClearInvalidPersistentData"=dword:00000000
```

the value of "ClearInvalidRetainData" or of "ClearInvalidPersistentData" must be set to 1.

Whether the backup file is to be used can also be set in the TwinCAT System Manager in the tree structure on the left under **PLC > PLC Settings**:

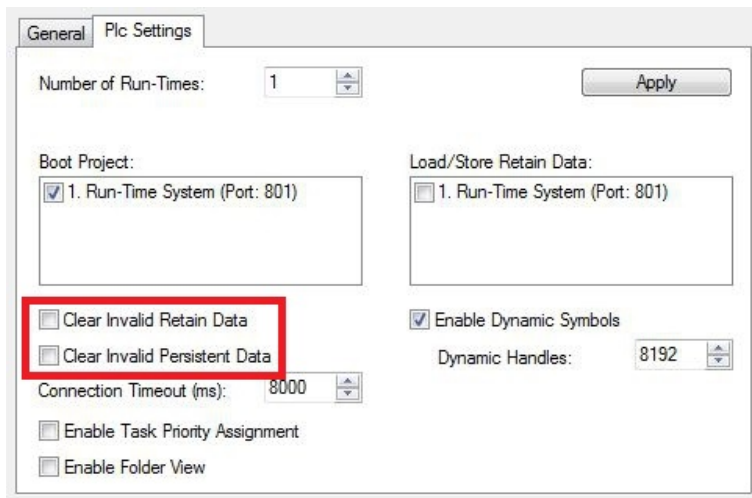

The backup files are deleted if the option **Clear Invalid Retain Data** or **Clear Invalid Persistent Data** is set in the System Manager. Corresponds to registry entry 1.

Development environment	Target platform	PLC libraries to be linked
TwinCAT v2.7.0	PC or CX (x86)	PLCSystem.Lib
TwinCAT v2.8.0	PC or CX (x86)	TcSystem.Lib
TwinCAT v2.10.0 Build >= 1301	CX (ARM)	TcSystem.Lib

9.3.2 PlcAppSystemInfo

Each PLC provides a global instance of this type named '_AppInfo'. The corresponding namespace is 'TwinCAT_SystemInfoVarList'. For example this has to be added inside a library.

```

TYPE PlcAppSystemInfo
STRUCT
  ObjId          : OTCID;
  TaskCnt        : UDINT;
  OnlineChangeCnt : UDINT;
  Flags          : DWORD;
  AdsPort        : UINT;
  BootDataLoaded : BOOL;
  OldBootData    : BOOL;
  AppTimestamp   : DT;
  KeepOutputsOnBP : BOOL;

  TComSrvPtr     : ITComObjectServer;

  AppName        : STRING(63);

  ProjectName    : STRING(63);
END_STRUCT
END_TYPE
    
```

ObjId	object ID of the PLC project instance
TaskCnt	The number of tasks in the actual runtime system.
OnlineChangeCnt	The number of online changes made since the last complete download.
Flags	Reserved for future use
AdsPort	ADS port of PLC application
BootDataLoaded	PERSISTENT variables: LOADED (without error)
OldBootData	PERSISTENT variables: INVALID (the back-up copy was loaded, since no valid data was present)
AppTimestamp	Date and time of application start
KeepOutputsOnBP	The flag can be set to avoid that the outputs are zero-filled if a breakpoint is reached. The task keeps running. Only the execution of PLC code is interrupted.
TComSrvPtr	Pointer to TcCOM Object Server
AppName	TwinCAT generated name containing the port number.
ProjectName	The name of the PLC project.

Differences to TwinCAT 2

If the variable runTimeNo was used under TwinCAT 2, the program code has to be changed.

Example

- **Usage in TwwincAT 2:** nPlcAdsPort := 801 + (SystemInfo.runTimeNo - 1) * 10;
- **Usage in TwinCAT 3:** nPlcAdsPort := _AppInfo.AdsPort;

10 Error handling and diagnostics

10.1 Diagnostic LEDs

Display	LED	Meaning
	PWR	Power supply The Power LED comes on when the device is connected to a live power supply unit (green). The LED blinks fast (red) if there is a power failure. The LED blinks slow (red) if there is no or an incorrect μ SD card inserted.
	TC	TwinCAT status LED TwinCAT is in Run mode (green) TwinCAT is in Stop mode (red) TwinCAT is in Config mode (blue)
	FB1	Status LED1 for fieldbus (function is written at the fieldbus interface)
	FB2	Status LED2 for fieldbus (function is written at the fieldbus interface)
	HDD 1	Indicates access to the μ SD card in slot 1. LED flashes green during read access. LED flahes yellow during write access.
	HDD 2	Indicates access to the μ SD card in slot 2. LED flashes green during read access. LED flahes yellow during write access.

10.2 Power supply terminal LEDs in K-bus mode

The power supply unit checks the connected Bus Terminals for errors. The red LED "K-bus ERR" is off if no error is present. The red LED "K-bus ERR" flashes if Bus Terminal errors are present.

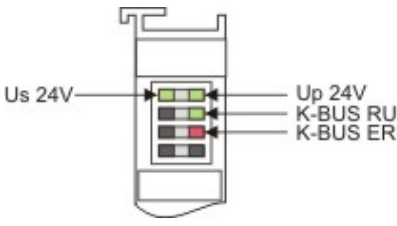
Display	LED	Meaning
	Us 24 V	Power supply for basic CPU module. The LED lights green if the power supply is correct.
	Up 24V	Power supply for terminal bus. The LED lights green if the power supply is correct.
	K-BUS RUN	Diagnostic K-bus. The green LED lights up in order to indicate fault-free operation. "Error-free" means that the communication with the fieldbus system is also running.
	K-BUS ERR	Diagnostic K-bus. The red LED flashes to indicate an error. The red LED blinks with two different frequencies.

The frequency and number of the flashes can be used to determine the error code and the error argument. An error is indicated by the "K-bus ERR" LED in a particular order.

Table 24: K-bus ERR LED, fault indication sequence through the LED.

Order	Meaning
Fast blinking	Starting the sequence
First slow sequence	Error code
No display	Pause, the LED is off
Second slow sequence	Error code argument

Count how often the red LED K-bus ERR flashes, in order to determine the error code and the error argument. In the error argument the number of pulses shows the position of the last Bus Terminal before the error. Passive Bus Terminals, such as a power feed terminal, are not included in the count.

Table 25: K-BUS ERR LED, fault description and troubleshooting.

Error code	Error code argument	Description	Remedy
Persistent, continuous flashing		EMC problems.	<ul style="list-style-type: none"> • Check power supply for undervoltage or overvoltage peaks. • Implement EMC measures. • If a K-bus error is present, it can be localized by a restart of the power supply (by switching it off and then on again)
3 pulses	0	K-bus command error.	<ul style="list-style-type: none"> • No Bus Terminal inserted. • One of the Bus Terminals is defective; halve the number of Bus Terminals attached and check whether the error is still present with the remaining Bus Terminals. Repeat this procedure until the faulty Bus Terminal has been found.
4 pulses	0	K-bus data error, break behind the power supply unit.	Check whether the Bus End Terminal 9010 is connected.
	n	Break behind Bus Terminal n	Check whether Bus Terminal n+1 after the power supply unit is connected correctly; replace if necessary.
5 pulses	n	K-bus error in register communication with Bus Terminal n.	Replace Bus Terminal at location n.
6 pulses	0	Error at initialization.	Replace Embedded PC.
	1	Internal data error.	Hardware reset of the Embedded PC (switch off and back on again).
	8	Internal data error.	Hardware reset of the Embedded PC (switch off and back on again).
7 pulses	0	Process data lengths of the set and actual configurations do not correspond.	Check the configuration and the Bus Terminals for consistency.

For some error the LED "K-BUS ERR" does not go out, even if the error was rectified. Switch the power supply for the power supply unit off and back on again to switch off the LED after the error has been rectified.

State variable

In TwinCAT there is a State variable under the Bus Coupler for K-bus diagnostics.

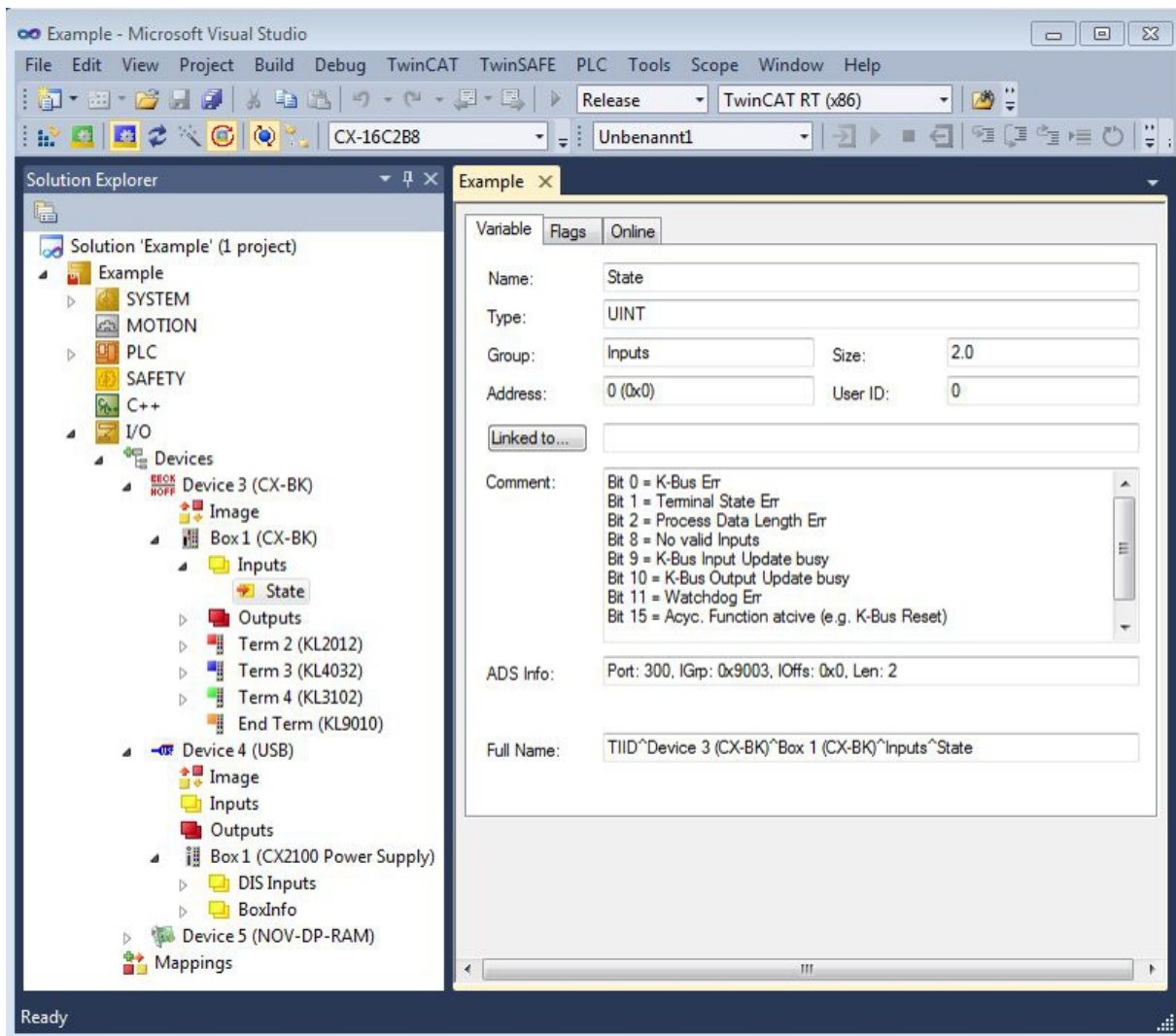

Fig. 29: Status variable for error handling and diagnostics under TwinCAT.

If the value is "0", the K-bus operates synchronous and without error. If the value is \neq "0" there may be a fault, or it may only be an indication that the K-bus cycle is longer than the task. In which case it would no longer be synchronous with the task. The task time should be faster than 100 ms. We recommend a task time of less than 50 ms. The K-bus update time typically lies between one and five ms.

Table 26: Description of the State variable values.

Bit	Description
Bit 0	K-bus error.
Bit 1	Terminal configuration has changed since the start.
Bit 2	Process image lengths do not match.
Bit 8	(still) no valid inputs.
Bit 9	K-bus input update not yet complete.
Bit 10	K-bus output update not yet complete.
Bit 11	Watchdog.
Bit 15	Acyclic K-bus function active (e.g. K-bus reset).

If there is a K-bus error, this can be reset via the IOF_DeviceReset function block (in the TcIoFunctions.lib).

10.3 Power supply terminal LEDs in K-bus mode

The power supply unit checks the connected EtherCAT Terminals. The "L/A" LED is lit in E-bus mode. The "L/A" LED flashes during data transfer.

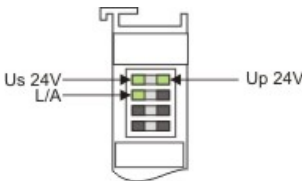
Display	LED	Meaning	
	Us 24 V	Power supply for basic CPU module. The LED lights green if the power supply is correct.	
	Up 24 V	Power supply for terminal bus. The LED lights green if the power supply is correct.	
	L / A	off	E-bus not connected.
		on	E-bus connected / no data traffic.
	flashes	E-bus connected / data traffic on the E-bus.	

10.4 Faults

Please also refer to the Safety instructions section.

Possible faults and their correction

Fault	Cause	Measures
no function after the Embedded PC has been switched on	no power supply for the Embedded PC other causes	1. Check fuse 2. Measure voltage at connection, check plug wiring Call Beckhoff support
Embedded PC does not boot fully	Hard disk damaged (e.g. due to switching off while software is running), incorrect setup, other causes	Check setup Call Beckhoff support
Computer boots, software starts, but control does not operate correctly	Cause of the fault is either in the software or in parts of the plant outside the Embedded PC	Call the manufacturer of the machine or the software.
µSD card access error	Faulty µSD card, faulty card slot	Use a different µSD card to check the card slot Call Beckhoff support
Embedded PC only works partially or temporarily	Defective components in the Embedded PC	Call Beckhoff support

Please make a note of the following information **before** contacting Beckhoff service or support:

1. Precise device ID: CXxxxx-xxxx
2. Serial number
3. Hardware version
4. Any interfaces (N030, N031, B110, ...)
5. TwinCAT version used
6. Any components / software used

The quickest response will come from support / service in your country. Therefore please contact your regional contact. For details please refer to our website at www.beckhoff.de or ask your distribution partner.

11 Care and maintenance

11.1 Replace the battery

 Attention	<p>Risk of explosion</p> <p>An incorrectly inserted battery may explode and damage the Embedded PC.</p> <p>Only use original batteries and ensure that the positive and negative poles are inserted correctly.</p>
---	---

The battery must be replaced every 5 years. Spare batteries can be ordered from Beckhoff Service. A battery of type CR2032 from Sanyo or Panasonic is used for the Embedded PC.

Table 27: Technical data of the battery.

Battery type	Electrical properties (at 20 °C)		Standard charge	Dimensions		
	nominal voltage	nominal capacity	continuous load	Diameter	Height	Weight
CR2032	3.0 V	225 mAh	0.20 mA	20.0 mm	3.20 mm	3.1 g

The battery compartment is below the front flap. The battery stores the time and date. The time and date are reset if the battery is removed.

Be aware of this behavior for your hardware and software configuration and reset the time and date after a battery change.

Requirements:

- The Embedded PC is switched off.

Replace the battery as follows:

1. Lever the front flap open with a screwdriver and remove it.
2. Carefully pull the battery from the bracket.

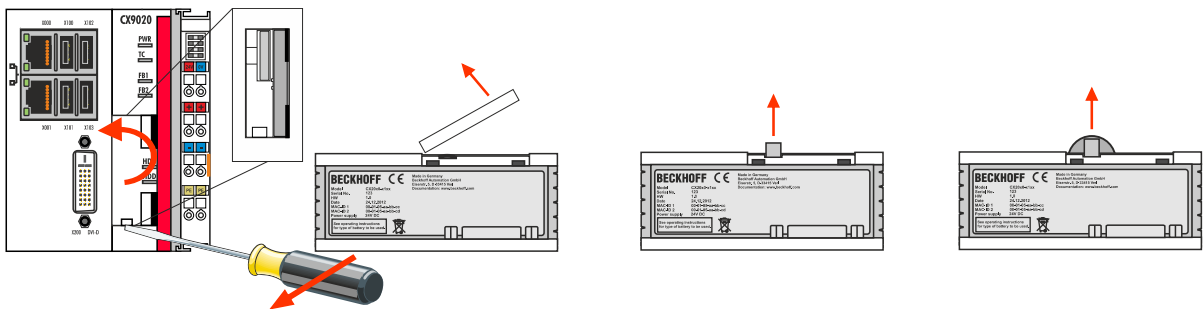

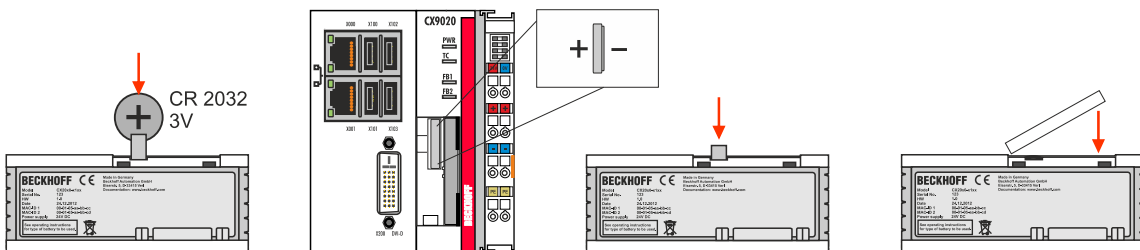

3. Push the new battery into the battery compartment. The positive pole points to the left towards the DVI-D interface.



⇒ The battery change is complete. Close the front flap and reset the time and date.

12 Decommissioning

12.1 Removing cables

 Note	<p>Electrical voltage</p> <p>Having the power supply switched on during the disassembly may damage the device. Switch off the power supply during the disassembly.</p>
 Note	<p>Cabling</p> <p>Make a note of the wiring configuration, if you wish to restore it with another device.</p>

Before dismantling the Embedded PC, shut down the Embedded PC and switch off the power supply. Only then can you remove all the cables. Also remove all cables from the first terminal after the power supply terminal.

Requirements:

- Exit the software and shut down the Embedded PC.
- Switch off the power supply.

Remove the cables as follows:

1. Remove the cabling from the Embedded PC.
2. Remove the wiring from the first terminal next to the power supply terminal.
3. Pull the orange strap to remove the first terminal after the power supply terminal by pulling it forward.

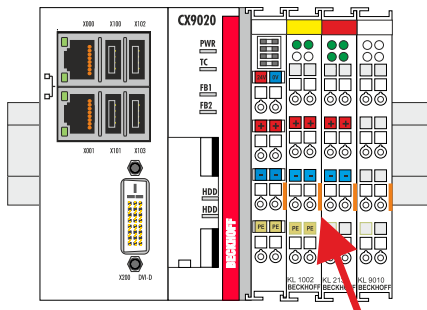

⇒ In the next step the Embedded PC can be removed from the DIN rail and dismantled.

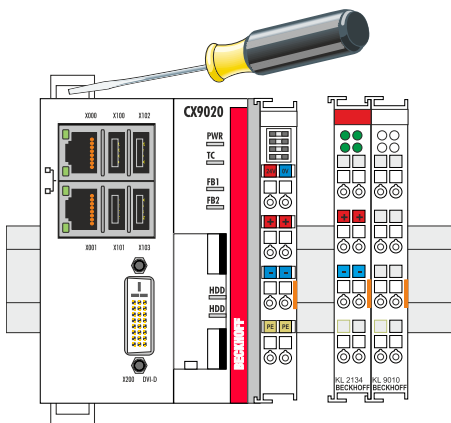

12.2 Dismantling the Embedded PC

This chapter explains how to dismantle the Embedded PC and remove it from the mounting rail.

Requirements:

- All cables were removed from the Embedded PC.

Dismantle the Embedded PC as follows:

1. Release the DIN rail mounting by pushing the latches outwards with a screwdriver.

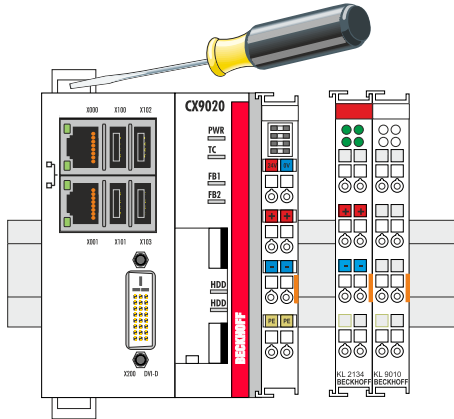

2. Pull the orange strap on the power supply terminal and gently remove the device from the DIN rail.

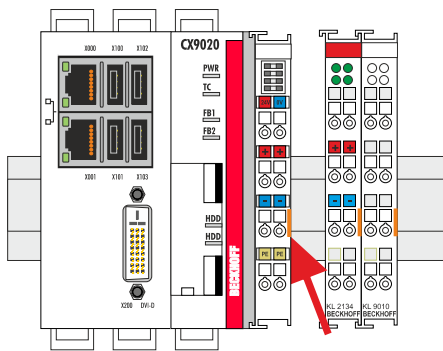

⇒ You have removed the Embedded PC successfully.

Disposal

The device must be fully dismantled in order to dispose of it. Electronic components must be disposed of according to national electronic waste regulations.

13 Technical data

Table 28: Technical data, dimensions and weights.

Technical data	CX9020
Weight	approx. 590 g
Dimensions (W x H x D)	84 mm x 99 mm x 91 mm

Table 29: Technical data, general data.

Technical data	CX9020
Processor	i.MX535 ARM Cortex™-A8, 1 GHz
Main memory	1 GB DDR3-RAM
Flash memory	256 MB MicroSD (optionally extendable), 2 x MicroSD card slot
NOVRAM integrated	128 kB
Power supply	24 V DC (-15 %/+20 %)
max. power loss	5 W (incl. the system interfaces)
Dielectric strength	500 Vrms (supply/internal electronics)
Operating system	Microsoft Windows Embedded Compact 7
Control software	TwinCAT-2-PLC runtime or TwinCAT-2-NC-PTP runtime
Diagnostics LED	1 x power, 1 x TC status, 2 x bus status, 2 x flash access
Clock	Internal battery-backed clock for time and date (battery replaceable)
Approvals	CE, UL, Ex, GL, IECEx

Table 30: Technical data, I/O terminals.

Technical data	Description
I/O connection	via power supply terminal (E-bus or K-bus, automatic detection)
Power supply for I/O terminals	max. 2A
Current load of the power contacts	max. 10 A
Process data on the K-bus	max. 2048 bytes input and 2048 bytes output
max. number of terminals (K-bus)	64 (255 with K-bus extension)
E-bus process data	max. 3328 bytes
max. number of terminals (E-bus)	up to 65534 terminals.

Table 31: Technical data, environmental conditions.

Technical data	Description
Ambient temperature during operation	-25 °C to +60 °C
Ambient temperature during storage	-40 °C to +85 °C See notes under: Transport and storage [► 11]
Relative humidity	95% without condensation
Vibration resistance	10 frequency sweeps in 3 axes 6 Hz < f < 58.1 Hz displacement 0.15 mm, constant amplitude 58.1 Hz < f < 500 Hz acceleration 5 g, constant amplitude according to EN 60068-2-6
Shock resistance	1000 shocks in each direction, in 3 axes 15 g, 11 ms according to EN 60068-2-27
EMC immunity	according to EN 61000-6-2
Electromagnetic emission	according to EN 61000-6-4
Protection class	IP 20

Table 32: Technical data, graphic specifications.

Technical data	Description
Processor graphics	Integrated graphics, ARM

Table 33: Technical data, interfaces.

Technical data	Description
LAN	2 x RJ 45, 10/100 MBit/s
USB	4 x USB 2.0 each rated at 500 mA, type A
DVI-D	Resolution on the monitor in pixels: 640 x 480 to 1920 x 1200

Table 34: Technical data, optional interfaces.

Technical data	Description
Audio	Line In, Line Out, Mic In
RS232	D-Sub plug, 9-pin Electrical isolation 500 V
RS422/RS485	D-Sub plug, 9-pin Electrical isolation 500 V
EtherCAT slave	2 x RJ 45, EtherCAT IN and OUT 100 MBaud
PROFIBUS	D-Sub plug, 9-pin 9.6 kbaud to 12 Mbaud
CANopen	D-Sub plug, 9-pin 10 kbaud to 1,000 kbaud
PROFINET RT	2 x RJ-45 switches

14 Appendix

14.1 Accessories

Table 35: MicroSD cards.

Order number	Description
CX1900-0122	512 MByte microSD card
CX1900-0124	1 GByte microSD card
CX1900-0126	2 GByte microSD card
CX1900-0128	4 GByte microSD card
CX1900-0130	8 GByte microSD card

larger capacities on request

Table 36: Passive DVI-to-VGA adaptor.

Order number	Description
CX1900-0101	Passive DVI-to-VGA adaptor for the connection of standard VGA monitors to the CX system – feeds out the VGA signals of the DVI-I interface of the CX module – DVI-A plug, 29-pin (bottom), socket, 15-pin (top) – Weight: approx. 40 g – Dimensions (W x H x D): 40 x 42 x 15 mm

Table 37: Spare battery for CX systems.

Order number	Description
CX1900-0102	Battery for CX systems Original manufacturer's designation: Panasonic type CR2032 3V/225 mAh

14.2 Certifications

All products of the Embedded PC family are CE, UL and EAC certified. Since the product family is continuously developed further, we are unable to provide a full listing here. The current list of certified products can be found at www.beckhoff.com.

FCC Approvals for the United States of America

FCC: Federal Communications Commission Radio Frequency Interference Statement

This equipment has been tested and found to comply with the limits for a Class A digital device, pursuant to Part 15 of the FCC Rules. These limits are designed to provide reasonable protection against harmful interference when the equipment is operated in a commercial environment. This equipment generates, uses, and can radiate radio frequency energy and, if not installed and used in accordance with the instruction manual, may cause harmful interference to radio communications. Operation of this equipment in a residential area is likely to cause harmful interference in which case the user will be required to correct the interference at his own expense.

FCC Approval for Canada

FCC: Canadian Notice

This equipment does not exceed the Class A limits for radiated emissions as described in the Radio Interference Regulations of the Canadian Department of Communications.

14.3 Support and Service

Beckhoff and their partners around the world offer comprehensive support and service, making available fast and competent assistance with all questions related to Beckhoff products and system solutions.

Beckhoff's branch offices and representatives

Please contact your Beckhoff branch office or representative for local support and service on Beckhoff products!

The addresses of Beckhoff's branch offices and representatives round the world can be found on her internet pages:

<http://www.beckhoff.com>

You will also find further documentation for Beckhoff components there.

Beckhoff Headquarters

Beckhoff Automation GmbH & Co. KG

Huelshorstweg 20
33415 Verl
Germany

Phone:	+49(0)5246/963-0
Fax:	+49(0)5246/963-198
e-mail:	info@beckhoff.com

Beckhoff Support

Support offers you comprehensive technical assistance, helping you not only with the application of individual Beckhoff products, but also with other, wide-ranging services:

- support
- design, programming and commissioning of complex automation systems
- and extensive training program for Beckhoff system components

Hotline:	+49(0)5246/963-157
Fax:	+49(0)5246/963-9157
e-mail:	support@beckhoff.com

Beckhoff Service

The Beckhoff Service Center supports you in all matters of after-sales service:

- on-site service
- repair service
- spare parts service
- hotline service

Hotline:	+49(0)5246/963-460
Fax:	+49(0)5246/963-479
e-mail:	service@beckhoff.com

List of tables

Table 1	Weight and dimensions.	11
Table 2	Available optional interfaces for the CX9020.	12
Table 3	Legend for the configuration.	13
Table 4	Legend for the name plate.	14
Table 5	CX9020 (1 GHz 1 core), ordering information for software.	15
Table 6	USB interfaces (X100, X101, X102, X103), pin assignment.	17
Table 7	Ethernet interface X000 and X001, pin assignment.	18
Table 8	DVI-D interface X200, pin assignment.	19
Table 9	DVI-D interface X200, resolution at the monitor.	19
Table 10	Line In /Line Out jack plugs, pin assignment.	20
Table 11	RS232 interface X300, pin assignment.	21
Table 12	RS422/485 interface, pin assignment.	22
Table 13	Default setting, RS485 without echo with end point (terminated).	22
Table 14	EtherCAT slave interface X300, pin assignment.	23
Table 15	PROFIBUS interface X310, pin assignment.	24
Table 16	Wire colors of the PROFIBUS line.	24
Table 17	CANopen interface X510, pin assignment.	25
Table 18	PROFINET RT interface, pin assignment.	26
Table 19	Legend for the connection example.	32
Table 20	Required wire cross-sections and strip lengths.	33
Table 21	Access data for the Beckhoff Device Manager on delivery.	36
Table 22	Legend for the tree view.	38
Table 23	Block modes.	50
Table 24	K-bus ERR LED, fault indication sequence through the LED.	57
Table 25	K-BUS ERR LED, fault description and troubleshooting.	58
Table 26	Description of the State variable values.	59
Table 27	Technical data of the battery.	62
Table 28	Technical data, dimensions and weights.	65
Table 29	Technical data, general data.	65
Table 30	Technical data, I/O terminals.	65
Table 31	Technical data, environmental conditions.	66
Table 32	Technical data, graphic specifications.	66
Table 33	Technical data, interfaces.	66
Table 34	Technical data, optional interfaces.	66
Table 35	MicroSD cards.	67
Table 36	Passive DVI-to-VGA adaptor.	67
Table 37	Spare battery for CX systems.	67

List of figures

Fig. 1	Structure of the CX9020 Embedded PC.....	13
Fig. 2	CX9020 type plate.....	14
Fig. 3	Nomenclature for the CX9020 Embedded PC.....	15
Fig. 4	USB interfaces (X100, X101, X102, X103).....	17
Fig. 5	USB interface, pin numbering.....	17
Fig. 6	Ethernet interface X000, X001.....	18
Fig. 7	Ethernet interface, pin numbering.....	18
Fig. 8	DVI-D interface X200.....	19
Fig. 9	Audio interface X300, X301, X302.....	20
Fig. 10	Line In / Line Out X300, X302 jack plugs.....	20
Fig. 11	Mic In X301 jack plug.....	20
Fig. 12	RS232 interface X300 with pin numbering.....	21
Fig. 13	RS485 interface X300 with pin numbering.....	22
Fig. 14	EtherCAT slave interface X300.....	23
Fig. 15	EtherCAT slave LAN interface, pin numbering.....	23
Fig. 16	PROFIBUS interface X310 with pin numbering.....	24
Fig. 17	CANopen interface X510 with pin numbering.....	25
Fig. 18	PROFINET RT interface X300.....	26
Fig. 19	PROFINET RT LAN interface, pin numbering.....	26
Fig. 20	CX9020 Embedded PC, permissible installation position.....	27
Fig. 21	CX9020 Embedded PC, invalid installation positions.....	28
Fig. 22	Identifying a passive EtherCAT Terminal in TwinCAT.....	31
Fig. 23	Passive EtherCAT Terminals, permissible installation.....	31
Fig. 24	Passive EtherCAT Terminals, invalid installation.....	31
Fig. 25	CX9020 Embedded PC in the tree view of TwinCAT 3, with attached EtherCAT Terminals (left) or Bus Terminals (right).....	38
Fig. 26	Controller behavior with and without NOVRAM.....	42
Fig. 27	Retain Handler write speed, up to 63 kB in 512 byte steps.....	47
Fig. 28	Retain Handler write speed, up to 8 kB in 64 byte steps.....	47
Fig. 29	Status variable for error handling and diagnostics under TwinCAT.....	59