

Preliminary datasheet.

MIS43x Integrated Stepper Motor up to 25Nm

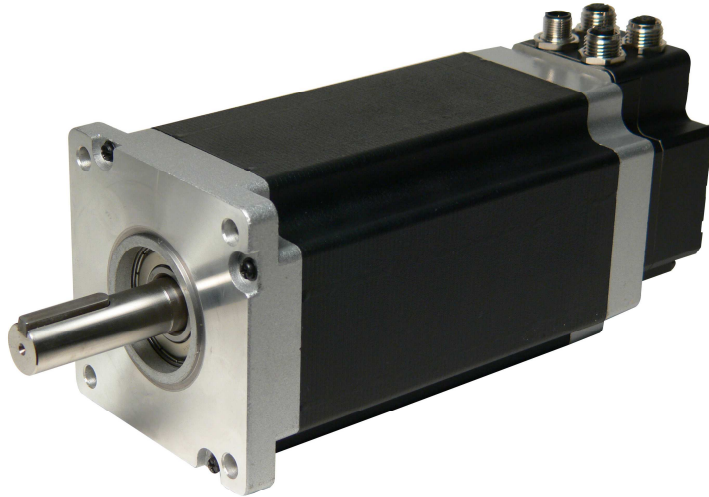

JVL is one of the world leading companies in the field of integrated servo and stepper motors.

JVL are now ready to reveal a prototype of our new QuickStep[®] integrated stepper motor in NEMA43 with RS485 programmable motion controller and optional industrial Ethernet, wireless and absolute multiturn encoder. The motor is very useful in applications where motors must be very compact, have very high torque at low speed and without backlash as a normal gear would offer.

All the necessary electronics in a stepper system are integrated in the motor itself. JVL has used the newest technology to obtain an incredibly high step resolution of 409,600 step/revolution – resulting in unsurpassed smoothness and silent running. The length is only 146 mm (5,75”) for a 10 Nm motor and it is therefore the shortest stepper motor in the world with built-in controller. The motors are available in 2 sizes:

- MIS430 with 10 Nm, Length 145 mm, Flange 110x110mm, 19mm shaft
- MIS432 with 25 Nm, Length 247 mm, Flange 110x110mm, 19mm shaft
-

The motor contains everything needed to solve a modern control task as stand-alone or controlled from a PLC or PC. 8 I/O points can be individually configured to digital input, digital output or analogue input. Modbus RTU, CANopen or Industrial Ethernet provides easy connections to a PLC or HMI. An ActiveX/OCX driver is available to make interfacing to LabView, Excel, VB or other Windows-programs simple. The MAC motor standard protocol enables MAC motors[®], QuickStep[®] motors and SMC85 as well as SMC75 controllers to be connected on the same RS485 bus with up to 254 axes. With Ethernet or wireless up to 65535 axes.

- Shortest length in the industry only 146 mm for 10 Nm
- Extreme Resolution up to 409600 step/rev equal to 2048 microsteps per fullstep
- Velocity precision 0.01 RPM. Acceleration precision 1 RPM/sec.
- Built-in PLC with 8 I/O: each DI or DO 24V or 0-5V (12bit) analogue input with advanced input filtering
- RS485 up to 2 Mbit and Modbus RTU
- Option: RS422 and RS485 for encoder I/O and connection to external HMI or PLC
- Point-to-point or multiaxis operation up to 254 axes on the same RS485 bus
- Pulse/Direction mode for electronic gearing
- Option built-in: CANbus with CANopen DSP402 and DS301
- Option built-in: Wireless LAN, Bluetooth or Zigbee.
- Option built-in: Industrial Ethernet EtherCAT, EtherNet/IP, Powerlink etc.
- Prepared for High speed position capture
- Wide Supply range from 12-80 VDC delivering high torque at high speeds
- Motor current 0-9 Amp RMS, 12.6 Amp Peak
- Dual supply maintain position values etc in emergency-stop situations
- ActiveX / OCX driver available as well as MacTalk protocol
- Powerful graphic programming with +/-*/ calculations and advanced functions
- All connections with M12 connectors, IP67
- Option for double shaft and single or absolute multiturn encoder

The integrated stepper motor can be delivered with wireless Bluetooth, ZigBee or WLAN. The motor is also prepared for future options like Profibus and Industrial Ethernet like EtherCAT and EtherNet/IP and absolute multiturn encoder without external battery. The PCB with stepper motor controller as used inside the motor is also available as type no. SMC85 with 9 Amp RMS.

Flange size is 110x110 mm which corresponds to the NEMA43 standard and shaft diameter is 19.0 mm with key. Planetary gears that fit the motor directly can also be delivered.

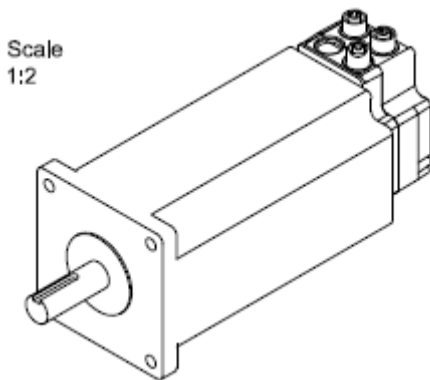

Technical data

	MIS430B22Q6xx85	MIS431B22Q6xx85	MIS432B22Q6xx85	
Holding Torque	10	21	25	Nm
Rotor moment of Inertia	5,5	10,9	16,2	Kgcm ²
Weight	5,5	8,9	12,2	Kg
Length (+2mm)	99+46=145	150+46=196	201+46=247	mm
Detent torque	0,35	0,63	0,75	Nm
Supply Voltage driver	12-80VDC	12-80VDC	12-80VDC	Volt DC
Control voltage	12-30VDC	12-30VDC	12-30VDC	Volt DC
Max Radial force Fr with axial force 80N	At 5mm max 640N, At 10mm max 425 N , At 15mm max 320N, At 20mm max 240N			
Shaft Play	Axial shaft play 0,075mm at load max 10N. Radial shaft play 0,025mm at load max 5N			
Step angle	1,8 degree +-5% (Non-Accumulating)			
Temperature	Ambient 0-40 degree or internal temperature sensor max 85% degree. Will depend in supple voltage and load.			
Humidity	Ambient humidity Max 85% (No condensation)			
Insulation	Insulation class B 130 degree Celsius [266°F]. Insulation resistance 100M ohm.			

MIS431 can only be delivered if orders above 50 pcs.

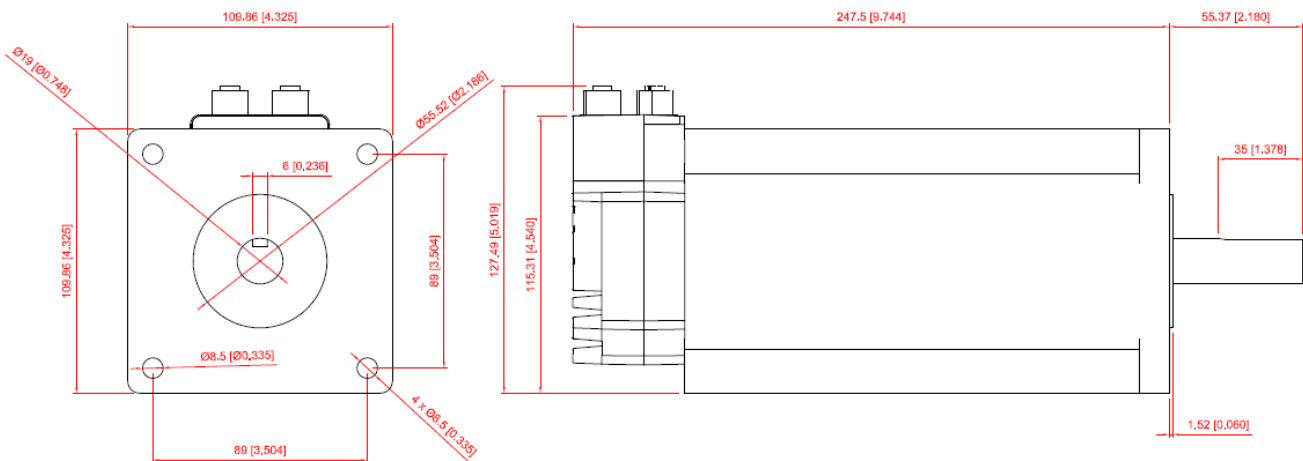

Torque/ speed curve for MIS43x integrated stepper motor.
Speed shown as fullstep/sec and Voltage 80VDC.

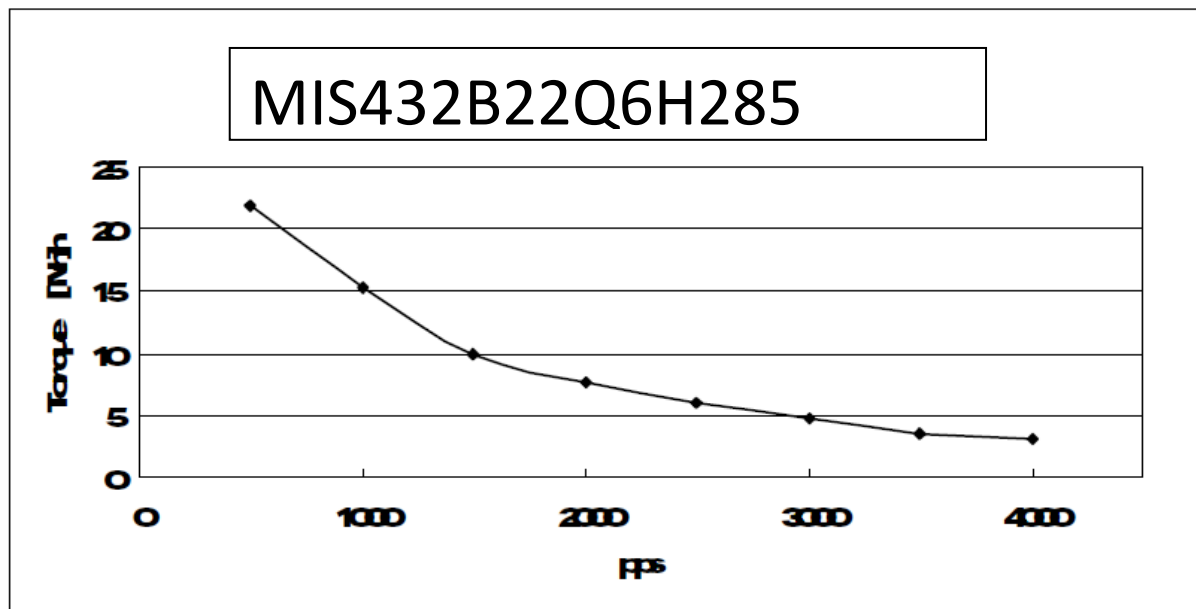
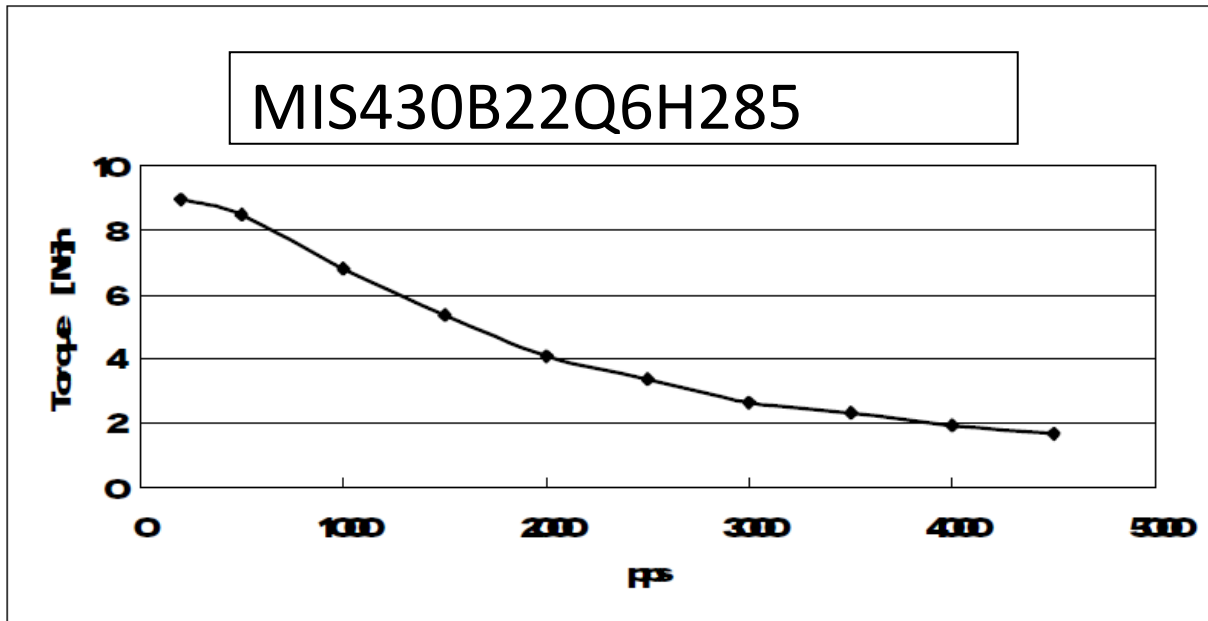

For further information, please contact:

JVL Industri Elektronik A/S, Blokken 42, 3460 Birkerød, Denmark. Tel. +45 4582 4440.

E-mail: jvlnyt@jvl.dk. Web: www.jvl.dk