



touchMATRIX Indicator AX350

Process indicator with two 16 bit analog inputs, touch screen and graphic display

Product Features:

- Operating modes for visualization of input 1, input 2 or combinations of inputs (IN1+IN2, IN2-IN2, IN1xIN2, IN1:IN2)
- Two universal 16 bit analog inputs for -10 ... +10 V / 0 ... 10 V / 0 ... 20 mA / 4 ... 20 mA
- High accuracy reference output 10 V for potentiometers > 1 kOhm
- Bright and high-contrast display with event-dependent color variations
- Emulation of a 7-segment display inclusively icons and units
- Intuitive and easy parameterization by plain text and touchscreen
- 24 V auxiliary output for encoder supply
- Totalization for each input
- Linearization with 24 control points for each input
- Numerous features, e. g. tara, averaging filter, sampling time for each input
- 3.78 x 1.89 inch norm panel housing and IP65 protection

Available Options:

- **AX350:** Basic unit with 2 analog inputs (16 Bit), 3 control inputs
- Option **AC:** Power supply 115...230 VAC
- Option **AO:** 16 bit analog output, 4 control outputs, serial RS232 interface
- Option **CO:** 4 control outputs, serial RS232 interface
- Option **RL:** 2 relay outputs

All options can be combined

Version:	Description
AX350_01a_oi/cn/Jan-17	First Version
AX350_02a_oi/cn/Feb-17	Second Version
AX350_02b_oi/cn/March-17	minor changes and fixes

Legal notices:

All contents included in this manual are protected by the terms of use and copyrights of motrona GmbH. Any reproduction, modification, usage or publication in other electronic and printed media as well as in the internet requires prior written authorization by motrona GmbH.

Table of Contents

1.	Safety Instructions and Responsibility.....	4
1.1.	General Safety Instructions.....	4
1.2.	Use according to the intended purpose.....	4
1.3.	Installation.....	5
1.4.	Cleaning, Maintenance and Service Notes.....	5
2.	Introduction.....	6
2.1.	Operation mode.....	6
3.	Electrical Connections.....	7
3.1.	DC Power Supply.....	7
3.2.	Auxiliary Voltage Output.....	7
3.3.	Analog Input.....	8
3.4.	Reference-output.....	8
3.5.	Control Inputs.....	9
3.6.	Analog Output (Option AO350).....	9
3.7.	Serial interface (Option AO / CO).....	10
3.8.	Control-Output (Option AO / CO).....	10
3.9.	AC Power supply (Option AC).....	11
3.10.	Relay-Output (Option RL).....	11
4.	Display and touch screen.....	12
4.1.	Screen structure for parametrization.....	12
4.2.	Screen structure in operation.....	13
5.	Parameter / Overview-Menu Structure.....	14
5.1.	General Menu.....	16
5.2.	IN 1 Properties.....	17
5.3.	IN 1 Linearization.....	20
5.4.	IN 1 Totalization.....	21
5.5.	IN 2 Properties.....	23
5.6.	IN 2 Linearization.....	24
5.7.	IN 2 Totalization.....	24
5.8.	Linkage Properties.....	25
5.9.	Preselection Values.....	27
5.10.	Preselection 1 Menu.....	28
5.11.	Preselection 2 Menu.....	32
5.12.	Preselection 3 Menu.....	33
5.13.	Preselection 4 Menu.....	34
5.14.	Serial Menu.....	35
5.15.	Analog Out Menu.....	37
5.16.	Command Menu.....	39
5.17.	Display Menu.....	41
6.	Appendix.....	43
6.1.	Data readout via serial interface.....	43
6.2.	Linearization.....	44
6.3.	Dimensions.....	46
6.4.	Technical specifications.....	47

1. Safety Instructions and Responsibility

1.1. General Safety Instructions

This operation manual is a significant component of the unit and includes important rules and hints about the installation, function and usage. Non-observance can result in damage and/or impairment of the functions to the unit or the machine or even in injury to persons using the equipment!

Please read the following instructions carefully before operating the device and observe all safety and warning instructions! Keep the manual for later use.

A pertinent qualification of the respective staff is a fundamental requirement in order to use these manual. The unit must be installed, connected and put into operation by a qualified electrician.

Liability exclusion: The manufacturer is not liable for personal injury and/or damage to property and for consequential damage, due to incorrect handling, installation and operation. Further claims, due to errors in the operation manual as well as misinterpretations are excluded from liability.

In addition the manufacturer reserves the right to modify the hardware, software or operation manual at any time and without prior notice. Therefore, there might be minor differences between the unit and the descriptions in operation manual.

The raiser respectively positioner is exclusively responsible for the safety of the system and equipment where the unit will be integrated.

During installation or maintenance all general and also all country- and application-specific safety rules and standards must be observed.

If the device is used in processes, where a failure or faulty operation could damage the system or injure persons, appropriate precautions to avoid such consequences must be taken.

1.2. Use according to the intended purpose

The unit is intended exclusively for use in industrial machines, constructions and systems. Non-conforming usage does not correspond to the provisions and lies within the sole responsibility of the user. The manufacturer is not liable for damages which have arisen through unsuitable and improper use.

Please note that device may only be installed in proper form and used in a technically perfect condition (in accordance to the Technical Specifications). The device is not suitable for operation in explosion-proof areas or areas which are excluded by the EN 61010-1 standard.

1.3. Installation

The device is only allowed to be installed and operated within the permissible temperature range. Please ensure an adequate ventilation and avoid all direct contact between the device and hot or aggressive gases and liquids.

Before installation or maintenance, the unit must be disconnected from all voltage-sources. Further it must be ensured that no danger can arise by touching the disconnected voltage-sources.

Devices which are supplied by AC-voltages must be connected exclusively by switches, respectively circuit-breakers with the low voltage network. The switch or circuit-breaker must be placed as near as possible to the device and further indicated as separator.

Incoming as well as outgoing wires and wires for extra low voltages (ELV) must be separated from dangerous electrical cables (SELV circuits) by using a double resp. increased isolation.

All selected wires and isolations must be conform to the provided voltage- and temperature-ranges. Further all country- and application-specific standards, which are relevant for structure, form and quality of the wires, must be ensured. Indications about the permissible wire cross-sections for wiring are described in the Technical Specifications.

Before first start-up it must be ensured that all connections and wires are firmly seated and secured in the screw terminals. All (inclusively unused) terminals must be fastened by turning the relevant screws clockwise up to the stop.

Overvoltages at the connections must be limited to values in accordance to the overvoltage category II.

For placement, wiring, environmental conditions as well as shielding and earthing/grounding of the supply lines the general standards of industrial automation industry and the specific shielding instructions of the manufacturer are valid. Please find all respective hints and rules on www.motrona.com/download.html --> “[General EMC Rules for Wiring, Screening and Earthing]”.

1.4. Cleaning, Maintenance and Service Notes

To clean the front of the unit please use only a slightly damp (not wet!), soft cloth. For the rear no cleaning is necessary. For an unscheduled, individual cleaning of the rear the maintenance staff or assembler is self-responsible.

During normal operation no maintenance is necessary. In case of unexpected problems, failures or malfunctions the device must be shipped for back to the manufacturer for checking, adjustment and reparation (if necessary). Unauthorized opening and repairing can have negative effects or failures to the protection-measures of the unit.

2. Introduction

This series of display unit is suitable for analog signals (-10 ... 10V or 0/4 ... 20 mA). It is very versatile in use, due to the intuitive handling and the extensive range of functions and options.

2.1. Operation mode

All functions are can be configured in the parameter menu.

The device can be set to one of the following operation modes:

- SINGLE:
single-channel operation of input 1
- DUAL:
two-channel operation of input 1 and 2
- IN 1 + IN 2:
two-channel operation of input 1 and 2 in combination with sum
- IN1 – IN 2:
two-channel operation of input 1 and 2 in combination with difference.
- IN 1 x IN 2:
two-channel operation of input 1 and 2 in combination with multiplication
- IN 1 / IN 2:
two-channel operation of input 1 and 2 in combination with division .

3.3. Analog Input

The reference potential (AGND) for the analog inputs is connected at terminal 5.
 The unit provides two 16 bit analog inputs at terminal 6 and 7. The characteristics of the analog inputs (voltage input or current input) can be set in the Menu IN 1/IN 2 PROPERTIES.



Important:
 Before connecting the sensor the configuration (voltage or current input) must be set!

Wiring of the incremental inputs:

Voltage input

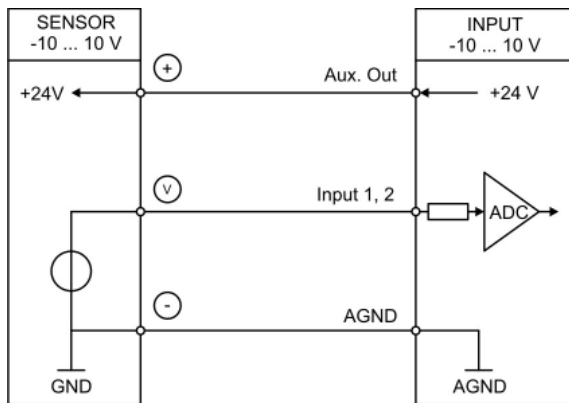

Current input

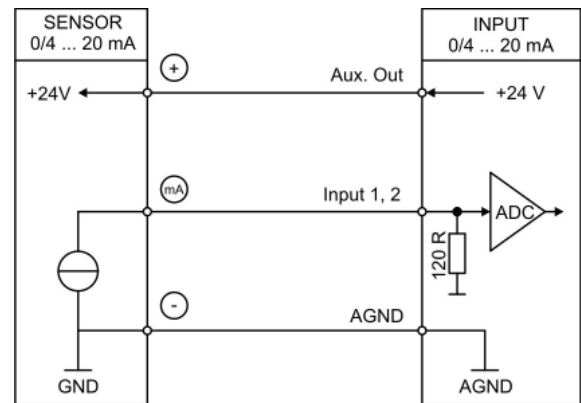

3.4. Reference-output

The unit provides a 10 V reference-output at terminal 8. This output should be loaded with 10 mA maximum. This reference-output can be used for connecting a potentiometer.

Referenz output with potentiometer:

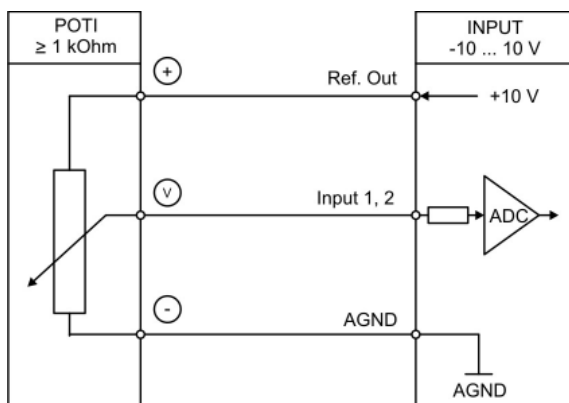

3.5. Control Inputs

The three control inputs at terminal 10, 11 and 12 have HTL PNP characteristics.

In the COMMAND MENU the programmable functions for the control inputs can be assigned. Available functions are: reset the display value, display switching, locking the touch screen or release the lock function of the control or relay outputs.

Wiring of the control inputs:

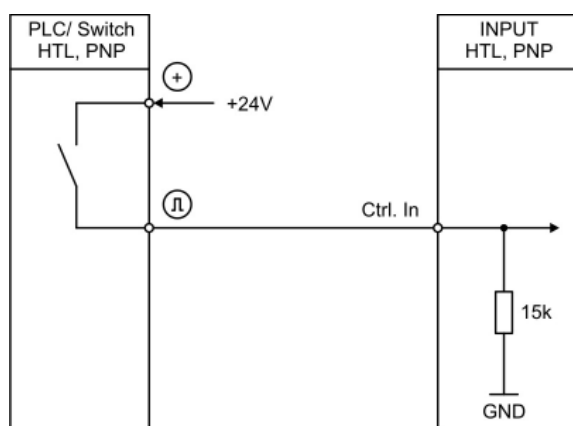

Unconnected control inputs are always "LOW".

All inputs are designed to receive impulses from an electronic impulse source.

Notice for mechanical switching contacts:

When exceptionally mechanical contacts are used, please connect an external capacitor between GND (-) and the corresponding input (+). A capacity of 10 μ F will reduce the input frequency to 20 Hz and miscounting due to contact bouncing will be eliminated.

3.6. Analog Output (Option A0350)

A 16 bit analog output is available at terminal 13 and 14 / 15.

This output can be configured and scaled in the ANALOG MENU.

The following configuration is possible:

- Voltage output: -10 ... +10 V
- Current output: 0 ... 20 mA
- Current output: 4 ... 20 mA

The analog output is proportional to the reference source and is referenced to potential AGND. AGND and GND are internally interconnected.



Important:
A parallel operation with voltage and current output at the analog output is not allowed.

3.7. Serial interface (Option A0 / C0)

A serial interface (RS232) is available at terminal 16, 17 und 18.
This interface can be configured in the SERIAL MENU.

The serial interface RS232 can be used:

- for easy setup and commissioning of the units
- to modify settings and parameters during operation
- to read out internal states and actual measuring values by PC or PLC

The following drawing shows the connection to a PC by using a standard Sub-D-9 connector:

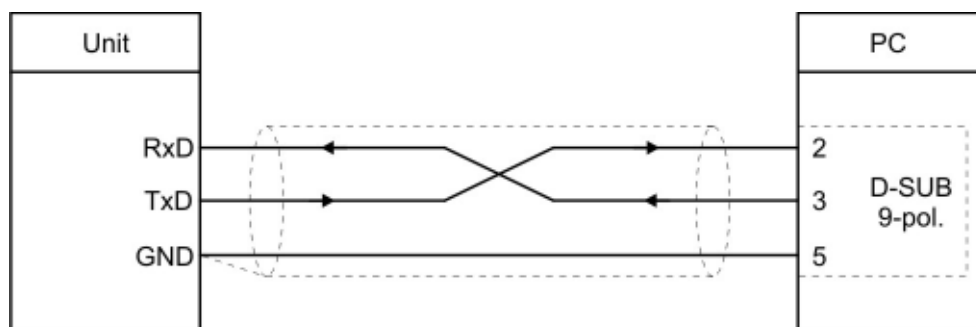

3.8. Control-Output (Option A0 / C0)

Four control outputs are available at terminal 20, 21, 22 and 23.

Switching conditions can be set in the PRESELECTION MENU. The output Ctrl. Out1 – 4 are fast PNP outputs with a switching capability of 5 – 30 Volt / 200 mA per channel. The switching states is displayed (display with unit and status bar) as C1 ... C4.

The switching voltage of the outputs must be applied to input terminal 19 (COM+).

In case of switching inductive loads it is advisable to use external filtering of the coils. The switching states is displayed (display with unit and status bar) as C1 and C4.

Wiring of the control-outputs:

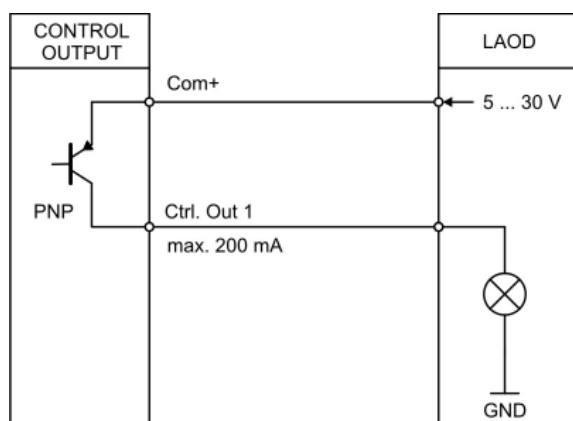

3.9. AC Power supply (Option AC)

The unit accepts AC supply from 115 to 230 V at the terminals 24 and 25. The power consumption depends on the level of the supply voltage and the additional current required at the auxiliary voltage output and is about 3 VA.

3.10. Relay-Output (Option RL)

Two relay outputs with potential-free changeover contacts are available at terminal 27, 28, 29 and 30, 31, 32. Switching conditions can be set in the PRESELECTION MENU. The switching states are displayed (display with unit and status bar) as K1 and K2.

AC-switching capacity max 250 VAC/max 3 A / max 750 VA

DC-switching capacity max 150 VDC /max 2 A / max 50 W

Wiring of the relay outputs:

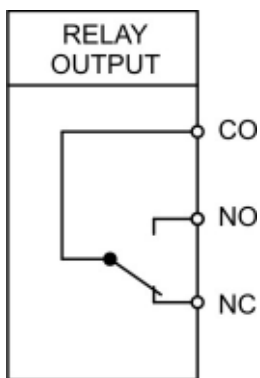

4. Display and touch screen

4.1. Screen structure for parametrization

The parameter menus and the parameters are described in chapter 5.



Start setup procedure:

To edit the parameters, press the touchscreen for 3 seconds.



Menu selection:

Select the parameter menu via arrow buttons and confirm with "OK".

The menu selection can be terminated with „C“.



Parameter selection:

Select the parameter via arrow buttons and confirm with „OK“.

The parameter selection can be terminated with „C“.



Parameter editing:

Edit the parameter via arrow button up and down, shift cursor via left and right and save with „OK“.

The parameter editing can be terminated with „C“.

Parameter changes becomes active only after closing the menu selection

4.2. Screen structure in operation

The following screens are available during operation. Depending on the device version and the selected operation mode, not all displays will be shown.

The source (IN1, IN2, ...) for the single channel display and the two channel display are defined in the DISPLAY MENU.



Single channel display with unit and status bar

To switch to the next display, press the touch screen.

Control - or Relay status are only shown with Option AO, CO, RL.



Two channel display

To switch to the next display, press the top of the screen.



Display for quick start for enter preselection values (PRESELECT VALUES)

To switch to the next display, press the top of the screen or the "skip" button.

This is only possible with Option AO, CO, RL

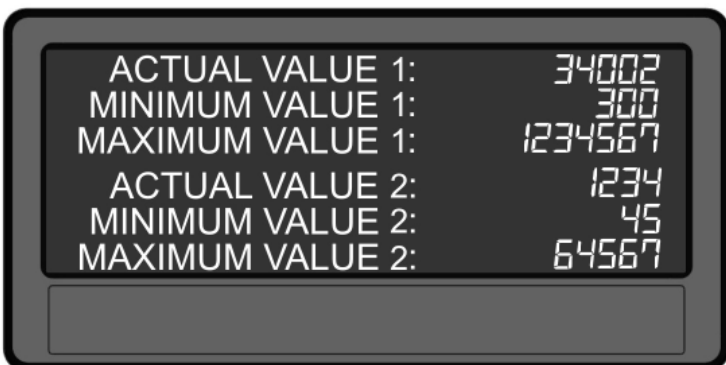

Display with actual / minimum / maximum values of input 1 and input 2

To switch to the next display, type on the touch screen.

5. Parameter / Overview-Menu Structure

This section provides an overview of the menus and their parameters. The menu names are printed bold and the associated parameters are listed under the menu name. Depending on the device version and the selected operation mode, only the necessary menus / parameters are shown.

Menu / Parameter
GENERAL MENU
OPERATIONAL MODE PIN PRESELECTION PIN PARAMETER BACK UP MEMORY FACTORY SETTINGS
IN 1 PROPERTIES
CONFIGURATION START VALUE END VALUE DECIMAL POINT SCALE UNITS SAMPLING TIME AVERAGE FILTER OFFSET LINEARIZATION TOTALIZATION
IN 1 LINEARIZATION
P1(X) P1(Y) P2(X) P2(Y) P23(X) P23(Y) P24(X) P24(Y)
IN 1 TOTALIZATION
TIME BASE DIVIDER DECIMAL POINT SCALE UNITS

Menu / Parameter
IN 2 PROPERTIES
CONFIGURATION START VALUE END VALUE DECIMAL POINT SCALE UNITS SAMPLING TIME AVERAGE FILTER OFFSET LINEARIZATION TOTALIZATION
IN 2 LINEARIZATION
P1(X) P1(Y) P2(X) P2(Y) P23(X) P23(Y) P24(X) P24(Y)
IN 2 TOTALIZATION
TIME BASE DIVIDER DECIMAL POINT SCALE UNITS
LINKAGE PROPERTIES
FACTOR DIVIDER ADDITIVE VALUE DECIMAL POINT SCALE UNITS
PRESELECTION VALUES
PRESELECTION 1 PRESELECTION 2 PRESELECTION 3 PRESELECTION 4

Menu / Parameter
PRESELECTION 1 MENU
SOURCE 1 MODE 1 HYSTERESIS 1 PULSE TIME 1 OUTPUT TARGET 1 OUTPUT POLARITY 1 OUTPUT LOCK 1 START UP DELAY 1 EVENT COLOR 1
PRESELECTION 2 MENU
SOURCE 2 MODE 2 HYSTERESIS 2 PULSE TIME 2 OUTPUT TARGET 2 OUTPUT POLARITY 2 OUTPUT LOCK 2 START UP DELAY 2 EVENT COLOR 2
PRESELECTION 3 MENU
SOURCE 3 MODE 3 HYSTERESIS 3 PULSE TIME 3 OUTPUT TARGET 3 OUTPUT POLARITY 3 OUTPUT LOCK 3 START UP DELAY 3 EVENT COLOR 3
PRESELECTION 4 MENU
SOURCE 4 MODE 4 HYSTERESIS 4 PULSE TIME 4 OUTPUT TARGET 4 OUTPUT POLARITY 4 OUTPUT LOCK 4 START UP DELAY 4 EVENT COLOR 4

Menu / Parameter
SERIAL MENU
UNIT NUMBER SERIAL BAUD RATE SERIAL FORMAT SERIAL INIT SERIAL PROTOCOL SERIAL TIMER SERIAL VALUE
ANALOG OUT MENU
ANALOG FORMAT ANALOG START ANALOG END ANALOG GAIN ANALOG OFFSET
COMMAND MENU
INPUT 1 ACTION INPUT 1 CONFIG INPUT 2 ACTION INPUT 2 CONFIG INPUT 3 ACTION INPUT 3 CONFIG
DISPLAY MENU
START DISPLAY SOURCE SINGLE SOURCE DUAL TOP SOURCE DUAL DOWN COLOR BRIGHTNESS CONTRAST SCREEN SAVER UP-DATE-TIME FONT

5.1. General Menu

OPERATIONAL MODE

This parameter specifies the selected measuring function.

0	SINGLE	Single channel mode, only input 1
1	DUAL	Dual channel mode, input 1 and input 2 separated
2	IN1 + IN 2	Dual channel mode, sum of input 1 and input 2
3	IN1 – IN 2	Dual channel mode, difference of input 1 and input 2
4	IN1 x IN 2	Dual channel mode, multiplication of input 1 and input 2
5	IN1 / IN 2	Dual channel mode, input 1 divide by input 2

PIN PRESELECTION

This parameter defines the PIN-code to lock the quick start of the menu PRESELECTION VALUE for entering the preselection values_(master PIN 6079).

This Lock function is only useful in conjunction with active lock function in PIN PARAMETER.

	0000	No lock
	...	
	9999	Access after entering PIN-Code 9999

PIN PARAMETER

This parameter defines the PIN-code for lock function of all parameters (master PIN 6079).

	0000	No lock
	...	
	9999	Parameterization of the unit after entering PIN-code 9999

BACK UP MEMORY

0	NO	No back –up by power failure
1	YES	Backup by power failure, actual value will be saved, only by totalization

FACTORY SETTINGS

0	NO	No default values are loaded
1	YES	Load default values of all parameters (grey marked default values)

5.2. IN 1 Properties

This menu defines the parameter for input 1.

CONFIGURATION		
This parameter defines the configuration of input 1.		
0	-10 ... 10 V	-10 ... 10 V
1	0 ... 20 MA	0 ... 20 mA
2	4 ... 20 MA	4 ... 20 mA

START VALUE		
This parameter defines the display value of an input signal of 0V, 0mA or 4mA. Signal values between START VALUE and END VALUE behave proportional.		
	-64999	Smallest start value
	0	Default value
	64999	Highest start value

END VALUE		
This parameter defines the display value of an input signal +10V bzw. 20mA. Signal values between START VALUE and END VALUE behave proportional.		
	-64999	Smallest end value
	10000	Default value
	64999	Highest end value

DECIMAL POINT		
This value defines the position of the decimal point.		
0	NO	No decimal point
1	0000000.0	Decimal point at the specified position
2	000000.00	Decimal point at the specified position
3	00000.000	Default decimal point at the specified position
4	0000.0000	Decimal point at the specified position
5	000.00000	Decimal point at the specified position
6	00.000000	Decimal point at the specified position
7	0.0000000	Decimal point at the specified position

Continuation „IN 1 Properties“:

SCALE UNITS

This parameter defines the required engineering unit. This parameter does not affect the calculation of the display value. The number of decimal places must be defined with the parameter DECIMAL POINT.

0	V	Default
1	mV	
2	A	
3	mA	
4	km/h	
5	mph	
6	feet/min	
7	inch/min	
8	g	
9	kg	
10	oz	
11	W	
12	kW	
13	VA	
14	mm	
15	cm	
16	m	
17	inch	
18	feet	
19	C	
20	F	
21	K	
22	1/sec	
23	1/min	
24	1/h	
25	gal/min	
26	Pa	
27	kPa	
29	%	
29		no unit

Continuation „IN 1 Properties“:

SAMPLING TIME (S)

The configured value corresponds to the sampling interval. This time interval in seconds defines the time between the single samples of the analog signals. This parameter directly affects the response time of the unit.

	0,001	Shortest sampling time
	0,01	Default value
	60,000	Longest sampling time

AVERAGE FILTER

Selectable average filter function to avoid measuring fluctuations.

	0	No average value will be created
	1	2 numbers of floating average cycles
	2	4 numbers of floating average cycles
	3	8 numbers of floating average cycles
	4	16 numbers of floating average cycles

OFFSET

This parameter defines the zero offset / tara of the input.

	-64.999	Smallest offset
	0	Default value
	+64.999	Highest offset

LINEARIZATION

This parameter defines the linearization function.

The linearization points are defined in Menu IN 1 / IN 2 LINEARIZATION.

See appendix.

	0	OFF	No linearization
	1	1 QUADRANT	Linearization in the 1. quadrant
	2	4 QUADRANT	Linearization in all 4 quadrants

TOTALIZATION

This parameter activates the totalization function. The settings will be done in Menu IN 1 / IN 2 TOTALIZATION.

The totalization depends on the operation mode. See chart in chapter IN 1 Totalization.

	0	OFF	No totalization
	1	ON	Totalization is active

5.3. IN 1 Linearization

The linearization points of input 1 are defined in this menu. This menu is shown only, if the linearization is selected in 1 PROPERTIES.

Linearization description and examples are shown in the appendix.

P1(X) ... P24(X)	
X-coordinate of the linearization point. This value representing the display value which the unit show in the display without linearization.	
-99999999	Smallest X-coordinate
0	Default value
+99999999	Largest X-coordinate

P1(Y) ... P24(Y)	
Y-coordinate of the linearization point This is the display value, which the unit should show in the display with linearization. E.g. P2(X) is replaced by P2(Y).	
-99999999	Smallest Y-coordinate
0	Default value
+99999999	Largest Y-coordinate

5.4. IN 1 Totalization

The totalization function is defined in this menu. This menu will only be showed, if the totalization is active in Menu IN 1 PROPERTIES.

The totalizer depends on the operation mode. See in the following list.

Operation mode	Totalisation		
	INPUT 1 TOTAL	INPUT 2 TOTAL	LINKAGE TOTAL
SINGLE	active	→ 0	→ 0
DUAL	active	active	→ 0
IN1 + IN 2	active	active	Total 1 + Total 2
IN1 – IN 2	active	active	Total 1 – Total 2
IN1 x IN 2	active	active	→ 0
IN1 / IN 2	active	active	→ 0

TIME BASE

This parameter defines the time base of the totalization.

It defines the time interval between the recordings of data.

0	SECONDS	The current value is added to INPUT 1 TOTAL every second
1	MINUTES	The current value is added to INPUT 1 TOTAL every minute
2	HOURS	The current value is added to INPUT 1 TOTAL every hour
3	COMMAND	The current value is added to INPUT 1 TOTAL, when using the command (ADD TO TOTAL 1) for the operation function at the control input (see Command Menu)

DIVIDER

This parameter defines the divisor for the totalization.

0	1	No division
1	10	The result of the totalization is divided by 10
2	100	The result of the totalization is divided by 100
3	1000	The result of the totalization is divided by 1000

DECIMAL POINT

This value defines the position of the decimal point.

0	NO	No decimal point
1	0000000.0	Decimal point at the specified position
2	000000.00	Decimal point at the specified position
3	00000.000	Decimal point at the specified position
4	0000.0000	Decimal point at the specified position
5	000.00000	Decimal point at the specified position
6	00.000000	Decimal point at the specified position
7	0.0000000	Decimal point at the specified position

Continuation „IN 1 Totalization“:

SCALE UNITS

This parameter defines the required engineering unit. This parameter does not affect the calculation of the display value. The number of decimal places must be defined with the parameter DECIMAL POINT.

0	V	Default
1	mV	
2	A	
3	mA	
4	km/h	
5	mph	
6	feet/min	
7	inch/min	
8	g	
9	kg	
10	oz	
11	W	
12	kW	
13	VA	
14	mm	
15	cm	
16	m	
17	inch	
18	feet	
19	C	
20	F	
21	K	
22	1/sec	
23	1/min	
24	1/h	
25	gal/min	
26	Pa	
27	kPa	
28	%	
29		No unit

5.5 IN 2 Properties

This menu defines the parameter for input 2.

CONFIGURATION

Configuration of input 2, see IN 1 Properties

START VALUE

Display value of input 2 at 0 V or 0/4 mA, see IN 1 Properties

END VALUE

Display value of input 2 at +10 V or 20 mA, see IN 1 Properties

DECIMAL POINT

Position of the decimal point, see IN 1 Properties

SCALE UNITS

The displayed units, see IN 1 Properties

SAMPLING TIME (S)

Sampling interval, see IN 1 Properties

AVERAGE FILTER

Selectable averages filter function, see IN 1 Properties.

OFFSET

Zero offset / tara, see IN 1 Properties

LINEARISATION

Linearization function, see IN 1 Properties.

TOTALIZATION

Totalization function, see IN 1 Properties.

5.6 IN 2 Linearization

The linearization points of input 2 are defined in this menu.

P1(X) ... P24(X)

X-coordinate of the linearization point, see IN 1 Linearization.

P1(Y) ... P24(Y)

Y-coordinate of the linearization point, see IN 1 Linearization.

5.7 IN 2 Totalization

The totalization function is defined in this menu.

TIME BASE

The time base of the totalization, see IN 1 Totalization

DIVIDER

The divisor for the totalization, see IN 1 Totalization.

DECIMAL POINT

Position of the decimal point, see IN 1 Totalization

SCALE UNITS

The displayed units, see IN 1 P Totalization

5.8 Linkage Properties

In this menu the parameters for the linked operation mode are defined. This menu is shown only, if in GENERAL MENU an operation mode (z.B. IN1 – IN2) with link was selected.

The parameters in Menu IN 1 PROPERTIES and IN 2 PROPERTIES have to be set, before using a linked operation mode.

The result of the link can be scaled with the following parameters.

FACTOR		
This parameter defines the factor, the result of the link will be charged.		
	-99999999	Smallest value
	1	Default value
	99999999	Highest end value

DIVIDER		
This parameter defines the divider, the result of the link will be charged..		
	-99999999	Smallest end value
	1	Default value
	99999999	Highest end value

ADDITIVE VALUE		
This parameter defines the additive constant, the result of the link will be charged.		
	-99999999	Smallest end value
	0	Default value
	99999999	Highest end value

DECIMAL POINT		
This value defines the position of the decimal point.		
	0 NO	No decimal point
	1 0000000.0	Decimal point at the specified position
	2 000000.00	Decimal point at the specified position
	3 00000.000	Decimal point at the specified position
	4 0000.0000	Decimal point at the specified position
	5 000.00000	Decimal point at the specified position
	6 00.000000	Decimal point at the specified position
	7 0.0000000	Decimal point at the specified position

Continuation „Linkage Properties Menu“:

SCALE UNITS

This parameter defines the required engineering unit. This parameter does not affect the calculation of the display value. The number of decimal places must be defined with the parameter DECIMAL POINT.

0	V	Default
1	mV	
2	A	
3	mA	
4	km/h	
5	mph	
6	feet/min	
7	inch/min	
8	g	
9	kg	
10	oz	
11	W	
12	kW	
13	VA	
14	mm	
15	cm	
16	m	
17	inch	
18	feet	
19	C	
20	F	
21	K	
22	1/sec	
23	1/min	
24	1/h	
25	gal/min	
26	Pa	
27	kPa	
	%	
		No unit

5.9 Preselection Values

This menu is used to set the preselection values or the switching points.

The preselection values / switching points are always referred to the display value.

This menu is only available for devices with option CO, A0 or RL.

PRESELECTION 1		
Preselection / switching point 1		
	-99999999	Smallest value
	1000	Default value
	+99999999	Highest value

PRESELECTION 2		
Preselection / switching point 2		
	-99999999	Smallest value
	2000	Default value
	+99999999	Highest value

PRESELECTION 3		
Preselection / switching point 3		
	-99999999	Smallest value
	3000	Default value
	+99999999	Highest value

PRESELECTION 4		
Preselection / switching point 4		
	-99999999	Smallest value
	4000	Default value
	+99999999	Highest value

5.10 Preselection 1 Menu

Switching conditions for preselection 1. Output/ relay/ display switches under the following conditions. This function is only available for devices with option CO, AO or RL.

SOURCE 1		
This parameter defines the reference source for PRESELECTION 1		
0	INPUT 1	the reference source is input 1
1	INPUT 2	the reference source is input 2
2	LINKAGE 1 – 2	the reference source is the result of the linking of input1 and input 2
3	INPUT 1 TOTAL	the reference source is input 1 with totalization
4	INPUT 2 TOTAL	the reference source is input 2 with totalization
5	LINKAGE TOTAL	the reference source is the result of the linking of input1 and input 2 with totalization

The totalization depends on the operation mode. See chart in chapter IN 1 Totalization.

Continuation „Preselection 1 Menu“:

MODE 1		
Switching conditions for preselection 1. Output/ relay/ display switches under the following conditions:		
0	$ \text{RESULT} \geq \text{PRES} $	<p>Absolute value of the display value is greater or equal absolute value of PRESELECTION 1</p> <p>With HYSTERESIS 1 not equal 0 the following switching condition is applied: Display value \geq PRESELECTION 1 \rightarrow ON, Display value $<$ PRESELECTION 1 – HYSTERESIS 1 \rightarrow OFF</p>
1	$ \text{RESULT} \leq \text{PRES} $	<p>Absolute value of the display value is less or equal absolute value of PRESELECTION 1 (start-up suppression (START UP DELAY) is advisable)</p> <p>With HYSTERESIS 1 not equal 0 the following switching condition is applied: Display value \leq PRESELECTION 1 \rightarrow ON, Display value $>$ PRESELECTION 1 + HYSTERESIS 1 \rightarrow OFF</p>
2	$ \text{RESULT} = \text{PRES} $	<p>Absolute value of the display value is equal absolute value of PRESELECTION 1 A range (Preselection +/- ½ Hysteresis) can be defined and monitored in conjunction with the hysteresis.</p> <p>With HYSTERESIS 1 not equal 0 the following switching condition is applied: Display value $>$ PRESELECTION 1 + ½ HYSTERESIS 1 \rightarrow OFF, Display value $<$ PRESELECTION 1 - ½ HYSTERESIS 1 \rightarrow OFF</p>
3	$\text{RESULT} \geq \text{PRES}$	<p>Display value is greater or equal PRESELECTION 1, e.g. overspeed</p> <p>With HYSTERESIS 1 not equal 0 the following switching condition is applied: Display value \geq PRESELECTION 1 \rightarrow ON, Display value $<$ PRESELECTION 1 – HYSTERESIS 1 \rightarrow OFF</p>
4	$\text{RESULT} \leq \text{PRES}$	<p>Display value is less or equal PRESELECTION 1, e.g. underspeed (start-up suppression (START UP DELAY) is advisable)</p> <p>With HYSTERESIS 1 not equal 0 the following switching condition is applied: Display value \leq PRESELECTION 1 \rightarrow ON, Display value $>$ PRESELECTION 1 + HYSTERESIS 1 \rightarrow OFF</p>
5	$\text{RESULT} = \text{PRES}$	<p>Display value is equal PRESELECTION 1. A range (Preselection +/- ½ Hysteresis) can be defined and monitored in conjunction with the hysteresis.</p> <p>With HYSTERESIS 1 not equal 0 the following switching condition is applied: Display value $>$ PRESELECTION 1 + ½ HYSTERESIS 1 \rightarrow OFF, Display value $<$ PRESELECTION 1 - ½ HYSTERESIS 1 \rightarrow OFF</p>
6	$\text{RES} \geq \text{PRES-TRAIL}$	<p>Trailing PRESELECTION 1: Display value is greater or equal PRESELECTION 2 – PRESELECTION 1, PRESELECTION 1 is the trailing preselection from PRESELECTION 2.</p>

Continuation „Preselection 1 Menu“:

HYSTERESIS 1		
This parameter defines the switching hysteresis of the switch-off point for preselection 1		
	0	No switching hysteresis
	...	
	99999	Switching hysteresis of 99999

PULSE TIME 1 (S)		
Duration of output pulse for the switching condition of preselection 1		
	0,000	No output pulse (static signal)
	...	
	60,000	Pulse duration of 60 seconds

OUTPUT TARGET 1		
Assignment of an output or relay for the switching condition of preselection 1. If more than one switching condition is assigned to one output / relay, the output is set when at least one switching condition is true		
	0 NO	No assignment
	1 CTRL OUT 1	Switching condition assigned to "Ctrl. Out 1"
	2 CTRL OUT 2	Switching condition assigned to "Ctrl. Out 2"
	3 CTRL OUT 3	Switching condition assigned to "Ctrl. Out 3"
	4 CTRL OUT 4	Switching condition assigned to "Ctrl. Out 4"
	5 RELAY 1	Switching condition assigned to "Rel. 1"
	6 RELAY 2	Switching condition assigned to "Rel. 2"

OUTPUT POLARITY 1		
Polarity for the switching condition of preselection 1		
	0 ACTIVE HIGH	Switching condition is true → Active „HIGH“
	1 ACTIVE LOW	Switching condition is true → Active „LOW“

OUTPUT LOCK 1		
Latch for the switching condition of preselection 1		
	0 NO	No latch for preselection
	1 YES	Latch for preselection (command LOCK RELEASE will clear latch)

Continuation „Preselection 1 Menu“:

START UP DELAY 1 (S)		
Start-up suppression for the switching condition of preselection 1. This adjustment is only valid for the switching condition $ RESULT \leq PRES $ or $RESULT \leq PRES$ (Start Up Delay 3 and 4 have an automatic start up suppression).		
	0.000	No start-up suppression
	...	
	60.000	Start-up suppression in seconds

EVENT COLOR 1			
Event-depending change of the display color for the switching condition of preselection 1. EVENT COLOR 1 has the lowest priority. EVENT COLOR 2 ... 4 are allowed to overwrite this color change.			
	0	NO CHANGE	No color change.
	1	CHANGE TO RED	Color change to red
	2	CHANGE TO GREEN	Color change to green
	3	CHANGE TO YELLOW	Color change to yellow

5.11 Preselection 2 Menu

SOURCE 2

The reference source for PRESELECTION 2, see PRESELECTION 1 MENU

MODE 2

Switching conditions for preselection 2, see PRESELECTION 1 MENU (expect trailing preselection)

		See chapter PRESELECTION 1 MENU
6	RES>=PRES-TRAIL	Trailing preselection 2: Display value is greater or equal to PRESELECTION 1 – PRESELECTION 2 PRESELECTION 2 is the trailing preselection from PRESELECTION 1.

HYSTERESIS 2

This parameter defines the switching hysteresis of the switch-off point for preselection 2.

See chapter PRESELECTION 1 MENU

PULSE TIME 2 (S)

Duration of output pulse for the switching condition of preselection 2.

See chapter PRESELECTION 1 MENU.

OUTPUT TARGET 2

Assignment of an output or relay for the switching condition of preselection 2.

See chapter PRESELECTION 1 MENU (expect default value).

		see PRESELECTION 1 MENU
2	CTRL OUT 2	Assignment of switching conditions at Ctrl. Out 2

OUTPUT POLARITY 2

Polarity for the switching condition of preselection 2.

See chapter PRESELECTION 1 MENU.

OUTPUT LOCK 2

Latch for the switching condition of preselection 2.

See chapter PRESELECTION 1 MENU.

START UP DELAY 2 (S)

Start-up suppression for the switching condition of preselection 2.

See chapter PRESELECTION 1 MENU.

(Start Up Delay 3 and 4 have an automatic start up suppression).

EVENT COLOR 2

Event-dependending change of the display color for the switching condition of preselection 2.

See chapter PRESELECTION 1 MENU.

5.12 Preselection 3 Menu

SOURCE 3

The reference source for PRESELECTION 3, see PRESELECTION 1 MENU

MODE 3

Switching conditions for preselection 3, see PRESELECTION 1 MENU (expect trailing preselection)

			See chapter PRESELECTION 1 MENU
	6	RES>=PRES-TRAIL	Trailing preselection 3: Display value is greater or equal to PRESELECTION 4 – PRESELECTION 3 PRESELECTION 3 is the trailing preselection from PRESELECTION 4.

HYSTERESIS 3

This parameter defines the switching hysteresis of the switch-off point for preselection 3.
See chapter PRESELECTION 1 MENU.

PULSE TIME 3 (S)

Duration of output pulse for the switching condition of preselection 3.
See chapter PRESELECTION 1 MENU (except default value).

OUTPUT TARGET 3

Assignment of an output or relay for the switching condition of preselection 3.
See chapter PRESELECTION 1 MENU.

			see PRESELECTION 1 MENU
	3	CTRL OUT 3	Assignment of switching conditions at Ctrl. Out 3

OUTPUT POLARITY 3

Polarity for the switching condition of preselection 3.
See chapter PRESELECTION 1 MENU.

OUTPUT LOCK 3

Latch for the switching condition of preselection 3.
See chapter PRESELECTION 1 MENU.

START UP DELAY 3

Start-up suppression for the switching condition of preselection 3.
This adjustment is only valid for the switching condition |RESULT|<=|PRES| or RESULT<=
(Start Up Delay 1 and 2 have a time-dependent start up suppression).

	0	OFF	No start-up suppression
	1	AUTO	Automatic start up suppression, until the preselection value / switching point is exceeded for the first time.

EVENT COLOR 3

Event-depending change of the display color for the switching condition of preselection 3.
See chapter PRESELECTION 1 MENU.

5.13. Preselection 4 Menu

SOURCE 4

The reference source for PRESELECTION 4, see PRESELECTION 1 MENU

MODE 4

Switching conditions for preselection 4, see PRESELECTION 1 MENU (expect trailing preselection)

			See chapter PRESELECTION 1 MENU
	6	RES>=PRES-TRAIL	Trailing preselection 4: Display value is greater or equal to PRESELECTION 3 – PRESELECTION 4 PRESELECTION 4 is the trailing preselection from PRESELECTION 3.

HYSTERESIS 4

This parameter defines the switching hysteresis of the switch-off point for preselection 4.
See chapter PRESELECTION 1 MENU.

PULSE TIME 4 (S)

Duration of output pulse for the switching condition of preselection 3.
See chapter PRESELECTION 1 MENU.

OUTPUT TARGET 4

Assignment of an output or relay for the switching condition of preselection 4.
See chapter PRESELECTION 1 MENU (except default value)..

			see PRESELECTION 1 MENU
	4	CTRL OUT 4	Assignment of switching conditions at Ctrl. Out 4

OUTPUT POLARITY 4

Polarity for the switching condition of preselection 4.
See chapter PRESELECTION 1 MENU.

OUTPUT LOCK 4

Latch for the switching condition of preselection 4.
See chapter PRESELECTION 1 MENU.

START UP DELAY 4

Start-up suppression for the switching condition of preselection 4, see PRESELECTION 3 MENU.
(Start Up Delay 1 and 2 have a time-dependent start up suppression).

	0	OFF	Automatic start up suppression,
	1	AUTO	until the preselection value / switching point is exceeded for the first time.

EVENT COLOR 4

Event-depending change of the display color for the switching condition of preselection 4.
See chapter PRESELECTION 1 MENU.

5.14. Serial Menu

This menu defines the basic settings of serial interface.

This function is only available for devices with option CO or A0

UNIT NUMMER		
This parameter defines serial device addresses. The addresses between 11 and 99 can be assigned to the devices. Addresses with zero are not allowed, there are used as broadcast addresses.		
	11	Smallest address
	...	
	99	Highest address

SERIAL BAUD RATE		
This parameter defines the serial baud rate		
0	9600	9600 baud
1	19200	19200 baud
2	38400	38400 baud

SERIAL FORMAT				
This parameter defines the bit data format.				
0	7-EVEN-1	7 data	Parity even	1 Stop
1	7-EVEN-2	7 data	Parity even	2 Stops
2	7-ODD-1	7 data	Parity odd	1 Stop
3	7-ODD-2	7 data	Parity odd	2 Stops
4	7-NONE-1	7 data	no Parity	1 Stop
5	7-NONE-2	7 data	no Parity	2 Stops
6	8-EVEN-1	8 data	Parity even	1 Stop
7	8-ODD-1	8 data	Parity odd	1 Stop
8	8-NONE-1	8 data	no Parity	1 Stop
9	8-NONE-2	8 data	no Parity	2 Stops

SERIAL INIT		
This parameter defines the baud rate for the initialization to the user interface OS6.0. With settings larger than 9600 the initialization time can be reduced..		
0	NO	Initialization with 9600 baud. Then the device operates with the value selected by the user.
1	YES	Initialization with the baud rate set by SERIAL BAUD RATE. Then the device operates with the value selected by the user.

Continuation „Serial Menu“:

SERIAL PROTOCOL														
Determines the sequence of characters send, when using the serial output for cyclic data transmission under time control (xxxxxx = value SERIAL VALUE).														
Setting „1“ removes the unit address from the string which allows a slight faster transmission cycle.														
0	Transmission report = Unit Nr., +/-, data, LF, CR <table border="1" style="margin-left: 20px;"> <tr> <td>1</td><td>1</td><td>+/-</td><td>X</td><td>X</td><td>X</td><td>X</td><td>X</td><td>X</td><td>X</td><td>LF</td><td>CR</td> </tr> </table>		1	1	+/-	X	X	X	X	X	X	X	LF	CR
1	1	+/-	X	X	X	X	X	X	X	LF	CR			
1	Transmission report = +/-, data, LF, CR <table border="1" style="margin-left: 20px;"> <tr> <td>+/-</td><td>X</td><td>X</td><td>X</td><td>X</td><td>X</td><td>X</td><td>X</td><td>X</td><td>LF</td><td>CR</td> </tr> </table>		+/-	X	X	X	X	X	X	X	X	LF	CR	
+/-	X	X	X	X	X	X	X	X	LF	CR				

SERIAL TIMER (S)		
This register determines the cycle time in seconds for cycling transmission of SERIAL VALUE when using the serial output. (On a serial request, the cycling transmission is stopped for 20 s)		
0.000	All cyclic transmission is switched off. The unit will send data upon a serial request or with command SERIAL PRINT.	
...		
60.000	Cycle time in seconds.	

SERIAL VALUE			
This parameter defines the value to be transmitted.			
Setting	Code	Register contents	
0	:0	Value input 1	
1	:1	Value input 2	
2	:2	Result of the linking of input1 and input 2	
3	:3	Result totalizator 1	
4	:4	Result totalizator 2	
5	:5	Result of the linking of 1 and 2 with totalization	
6	:6	Minimum value input 1	
7	:7	Maximum value input 1	
8	:8	Minimum value input 2	
9	:9	Maximum value input 2	

5.15. Analog Out Menu

This menu defines the basic settings of the analog output. This function is only available for devices with option A0.

SOURCE 1		
This parameter defines the reference source for PRESELECTION 1		
	INPUT 1	the reference source is input 1
	INPUT 2	the reference source is input 1
	LINKAGE 1 – 2	the reference source is the result of the linking of input1 and input 2
	INPUT 1 TOTAL	the reference source is input 1 with totalization
	INPUT 2 TOTAL	the reference source is input 1 with totalization
	LINKAGE TOTAL	the reference source is the result of the linking of input1 and input 2 with totalization

The totalization depends on the operation mode. See chart in chapter IN 1 Totalization.

ANALOG FORMAT		
This parameter defines the output characteristics. The analogue output is proportional to the display value. With setting ANALOG FORMAT (-10 ... +10 V) in MODE COUNTER the polarity of the analog output depends on the polarity of the display value.		
0	-10...10V	-10 ... +10 V
1	0...20MA	0 ... 20 mA
2	4...20MA	4 ... 20 mA

ANALOG START		
This parameter defines the start value of the analog conversion. This start value is corresponding to the display value for an analog output of 0 V or 0/4 mA.		
	-99999999	Smallest start value
	0	Default value
	+99999999	Highest start value

ANALOG END		
This parameter defines the end value of the analog conversion. This end value is corresponding to the display value for an analog output of (+/-) 10 V or 20mA.		
	-99999999	Smallest end value
	10000	Default Wert
	+99999999	Highest end value

Continuation „Analog Out Menu“:

ANALOG GAIN (%)							
This parameter specifies the maximum conversion of the analog output in %.							
e. g. 102.00 corresponds to a conversion of 10.2 V or 20.4 mA, when the ANALOG END value is reached.							
e. g. 95.00 corresponds to a conversion of 9.5 V or 18 mA, when the ANALOG END value is reached..							
	<table border="1"> <tr> <td>0,00</td> <td>Smallest gain</td> </tr> <tr> <td>100,00</td> <td>Default value</td> </tr> <tr> <td>110,00</td> <td>Highest gain</td> </tr> </table>	0,00	Smallest gain	100,00	Default value	110,00	Highest gain
0,00	Smallest gain						
100,00	Default value						
110,00	Highest gain						

ANALOG OFFSET (%)							
This parameter defines the zero offset of the analog output.							
z. B. 0.20 result in an offset of 0.02 V or 0.04 mA at ANALOG START value							
	<table border="1"> <tr> <td>-99,99</td> <td>Smallest offset</td> </tr> <tr> <td>0</td> <td>Default value</td> </tr> <tr> <td>+99,99</td> <td>Highest offset</td> </tr> </table>	-99,99	Smallest offset	0	Default value	+99,99	Highest offset
-99,99	Smallest offset						
0	Default value						
+99,99	Highest offset						

5.16. Command Menu

INPUT 1 ACTION			
This parameter defines the function of the input "Ctrl. In 1".			
0	NO	No function	
1	TARA INPUT 1	Value of input 1 is stored as an OFFSET of input 1	(d)
2	TARA INPUT 2	Value of input 2 is stored as an OFFSET of input 2	(d)
3	TARA INPUT 1+2	Value of input 1 is stored as an OFFSET of input 1 Value of input 1 is stored as an OFFSET of input 1	(d)
4	RESET TOTAL 1	Value of totalizator 1 is reset to zero	(d) (s)
5	RESET TOTAL 2	Value of totalizator 2 is reset to zero	(d) (s)
6	RESET TOTAL 1+2	Value of totalizator 1 is reset to zero Value of totalizator 2 is reset to zero	(d) (s)
7	TEACH PRESEL. 1	Value (SOURCE 1) is stored as PRESELECTION 1	(d)
8	TEACH PRESEL. 2	Value (SOURCE 2) is stored as PRESELECTION 2	(d)
9	TEACH PRESEL. 3	Value (SOURCE 3) is stored as PRESELECTION 3	(d)
10	TEACH PRESEL. 4	Value (SOURCE 4) is stored as PRESELECTION 4	(d)
11	SCROLL DISPLAY	Display switching (see chapter Screen structure in operation)	(d)
12	RESET MIN/MAX	Reset the Min. / Max. values	(d) (s)
13	CLEAR LOOP TIME	N.A.	
14	ACTIVATE	N.A.	
15	STORE DATA	N.A.	
16	TESTPROGRAM	N.A.	
17	SET RED COLOR	Red display: Event-dependending change of the display color by a switching condition is possible (see PRESELECTION 1...4 MENU)	(d)
18	SET GREEN COLOR	Green display: Event-dependending change of the display color by a switching condition is possible (see PRESELECTION 1...4 MENU)	(d)
19	SET YELLOW COLOR	Yellow display: Event-dependending change of the display color by a switching condition is possible (see PRESELECTION 1...4 MENU)	(d)
20	FREEZE	Freezing the display value	(s)
21	KEY LOCK	Key looked touch screen	(s)
22	LOCK RELEASE	No latch for preselection	(d)
23	SERIAL PRINT	Send serial data, see SERIAL VALUE	(d)
24	START PRESELECT	N.A.	
25	ADD TO TOTAL 1	Adds the current value of input 1 to INPUT 1 TOTAL	(d)
26	ADD TO TOTAL 2	Adds the current value of input 2 to INPUT 2 TOTAL	(d)

- (s) = statistical characteristic (level evaluation)
INPUT CONFIG must be set to ACTIVE LOW/HIGH
- (d) = dynamical characteristic (edge evaluation)
INPUT CONFIG must be set to RISING/FALLING EDGE

Continuation „Command Menu:“

INPUT 1 CONFIG

This parameter defines the switching characteristics of the input "Ctrl. In 1".

0	ACTIVE LOW	Active at „LOW“ (static)
1	ACTIVE HIGH	Active at „HIGH“ (static)
2	RISING EDGE	Activate at rising edge (dynamic)
3	FALLING EDGE	Activate at falling edge (dynamic)

INPUT 2 ACTION

This parameter defines the function of the input "Ctrl. In 2".

See parameter INPUT 1 ACTION

INPUT 2 CONFIG

This parameter defines the switching characteristics of the input "Ctrl. In 2".

See parameter INPUT 1 CONFIG.

INPUT 3 ACTION

This parameter defines the function of the input "Ctrl. In 3".

See parameter INPUT 1 ACTION.

INPUT 3 CONFIG

This parameter defines the switching characteristics of the input "Ctrl. In 3".

See parameter INPUT 1 CONFIG.

5.17. Display Menu

Parameter changes become active only after closing the menu selection.

START DISPLAY		
This parameter defines the start display after switching on the device.		
0	Single	Single-channel display The source must be defined in SOURCE SINGLE
1	Dual	The sources must be defined in SOURCE DUAL TOP / DOWN.

SOURCE SINGLE		
0	INPUT 1	the reference source is input 1
1	INPUT 2	the reference source is input 2
2	LINKAGE 1 – 2	the reference source is the result of the linking of input1 and input 2
3	INPUT 1 TOTAL	the reference source is input 1 with totalization
4	INPUT 2 TOTAL	the reference source is input 2 with totalization
5	LINKAGE TOTAL	the reference source is the result of the linking of input1 and input 2 with totalization

SOURCE DUAL TOP		
0	INPUT 1	the reference source is input 1
1	INPUT 2	the reference source is input 2
2	LINKAGE 1 – 2	the reference source is the result of the linking of input1 and input 2
3	INPUT 1 TOTAL	the reference source is input 1 with totalization
4	INPUT 2 TOTAL	the reference source is input 2 with totalization
5	LINKAGE TOTAL	the reference source is the result of the linking of input1 and input 2 with totalization

SOURCE DUAL DOWN		
0	INPUT 1	the reference source is input 1
1	INPUT 2	the reference source is input 2
2	LINKAGE 1 – 2	the reference source is the result of the linking of input1 and input 2
3	INPUT 1 TOTAL	the reference source is input 1 with totalization
4	INPUT 2 TOTAL	the reference source is input 2 with totalization
5	LINKAGE TOTAL	the reference source is the result of the linking of input1 and input 2 with totalization

The totalization depends on the operation mode. See chart in chapter IN 1 Totalization.

Continuation „ Display Menu“:

COLOR

This parameter defines the display color.

Event-depending change of the display color by a switching condition is possible (see PRESELECTION 1...4 MENU)

Event-depending changes are only available for devices with option CO350, A0350 or RL350.

	0	RED	Red display
	1	GREEN	Green display
	2	YELLOW	Yellow display

BRIGHTNESS (%)

This parameter defines the brightness of the display in percent

	10	Min. brightness
	80	Default value
	100	Max. brightness

CONTRAST

This parameter defines the viewing angle..

	0	Viewing angle from top
	1	Viewing angle from center
	2	Viewing angle from bottom

SCREEN SAVER (S)

This parameter defines the time in seconds until the display is switched off, after the last touch action.

A new touch action will activate the display again.

	0	No switch off
	...	
	9999	Longest time to switch off

UP-DATE-TIME (S)

This parameter defines the update time in seconds of the display only.

	0,005	Shortest update time
	0,1	Default value
	9,999	Longest update time

FONT

This parameter defines the setting of the font style.

	0	Standard
	1	Font 1

6. Appendix

6.1. Data readout via serial interface

All codes shown in the parameter SERIAL VALUE are available for serial readout by PC or PLC. For communication the monitors use the Drivecom Protocol according to ISO 1745. All protocol details can be found in our manual SERPRO_2a.doc which is available for download from our homepage www.motrona.com.

To request for a data transmission you must send the following request string to the converter:

EOT	AD1	AD2	C1	C2	ENQ
-----	-----	-----	----	----	-----

EOT = control character (Hex 04)

AD1 = unit address, High Byte

AD2 = unit address, Low Byte

C1 = register code, High Byte

C2 = register code, Low Byte

ENQ = control character (Hex 05)

The following example shows the request string for readout of the actual input frequency of a monitor (Code :1) from a unit with unit address 11:

ASCII-Code:	EOT	1	1	:	1	ENQ
Hex-Code:	04	31	31	3A	31	05
Binary-Code:	0000 0100	0011 0001	0011 0001	0011 1010	0011 0001	0000 0101

After a correct request, the unit will respond:

STX	C1	C2	xxxxx	ETX	BCC
-----	----	----	-------	-----	-----

STX = control character (Hex 02)

C1 = register code, High Byte

C2 = register code, Low Byte

xxxxx = readout data

ETX = control character (Hex 03)

BCC = block check character

6.2. Linearization

The linearization function of this unit allows converting a linear input signal into a non-linear developing (or vice versa). There are 24 programmable x/y coordinates available for input 1 and input 2, which can be set in any desired distance over the full conversion range. Between two coordinates, the unit uses linear interpolation. Therefore it is advisable to use more coordinates in a range with strong curves and only a few coordinates where the curvature is less.

To specify an individual linearization curve, the parameter LINEARISAZATION MODE must be set to either 1 QUADRANT or 4 QUADRANT (see following diagram).

The parameters P1(X) to P24(X) are used to specify the coordinates on the x-axis. These are the measuring values that the unit normally would generate according to the actual input signal.

Now enter the attached values to parameter P1(Y) to P24(Y). These are the values that the unit will generate instead of the x- values, i.e. P5(Y) replaces P5(X) etc.

The X-Coordinates must use continuously increasing settings, i.e. P1(X) must have the lowest and P24(X) must have the highest setting. If the measured value is bigger than the last defined X-value, the corresponding Y-value is displayed.

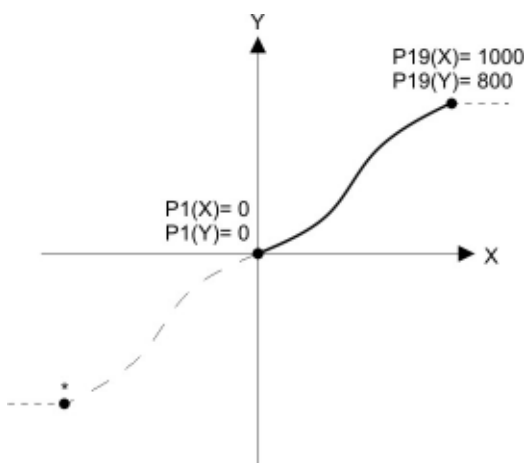

Example: Linearization Mode: 1 Quadrant
* Linearization is point symmetric to 1. Quadrant

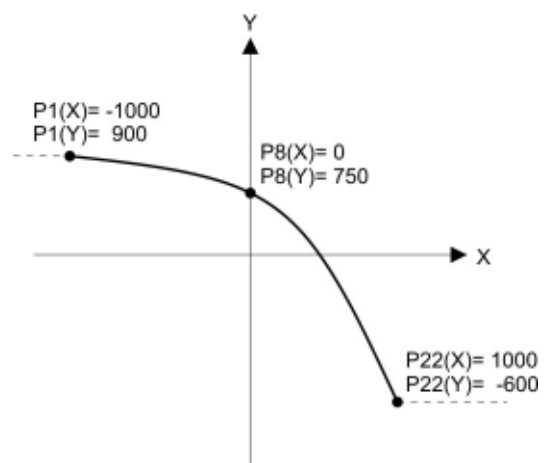

Example: Linearization Mode: 4 Quadrant

Mode: 1 Quadrant:

P1(X) must be set to zero. Linearization is only defined in the positive range and the negative range will be mirrored symmetric to central point.

Mode: 4 Quadrant:

P1(X) can also be set to a negative value. If the measured value is smaller than P1(X), P1(Y) is displayed.

Application Example:

We like to display the filling quantity (volume) of a tank as shown below, with use of a pressure sensor mounted to the bottom of the tank. With this application the analogue pressure signal is proportional to the filling level, but not to the filling quantity.

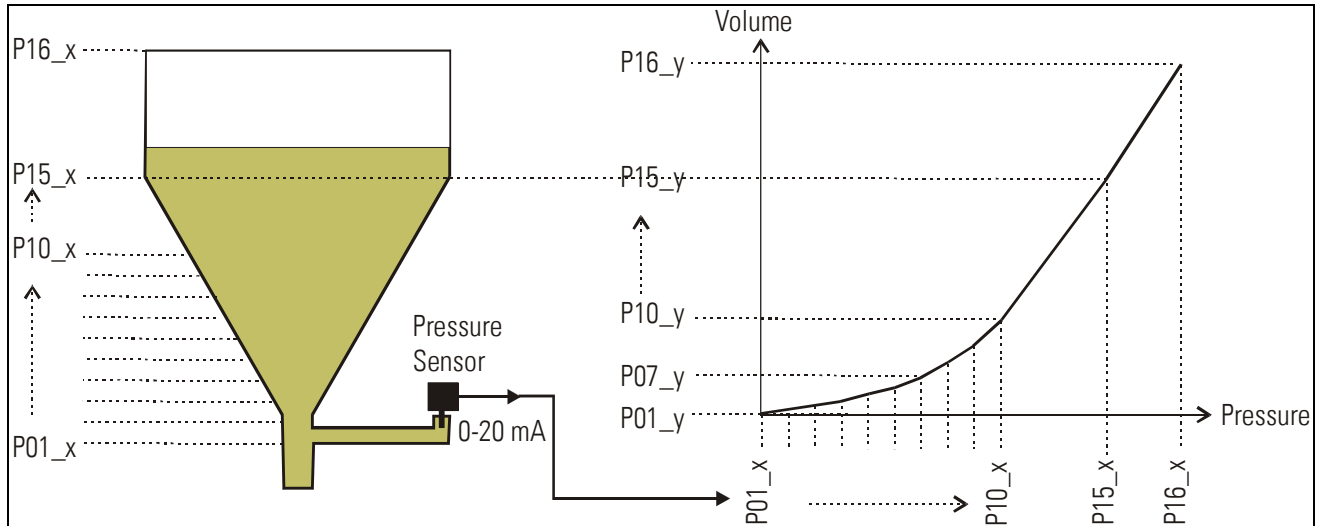

To solve the problem, we divide the non-linear part of the tank into 14 parts. We enter the expected display values of the pressure sensor to registers P01_x to P15_x.

For the linear part of the tank it is sufficient to store the final pressure value to register P16_x.

Now we can easily calculate the appropriate filling quantities and enter these values to the registers P01_y to P16_y.

6.3. Dimensions

Dimension in mm [inch]

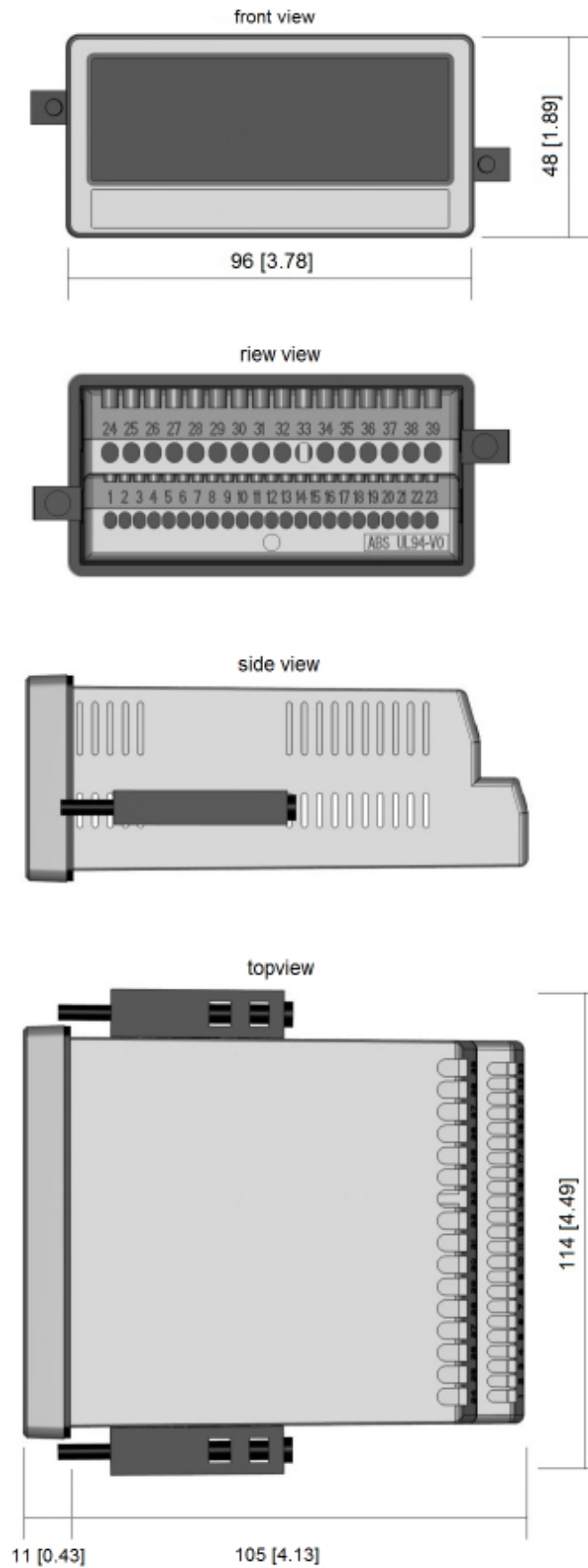

6.4. Technical specifications

Technical Specifications:		
Connections:	Connector type:	screw terminal, 1.5 mm ² / AWG 16
Power supply (DC):	Input voltage:	18 ... 30 VDC
	Protection circuit:	reverse polarity protection
	Consumption:	approx. 100 mA (unloaded)
	Fuse protection:	extern: T 0,5A
Power supply (AC): (Option AC)	Input voltage:	115...230 VAC, 50...60 Hz
	Power consumption:	approx. 3 VA (unloaded)
	Fuse protection:	extern: T 0,1 A
Encoder supply:	DC version:	approx. 1 V lower than the power supply voltage
	Output current:	max. 250 mA
	AC version (AC350):	approx. 24 V (± 15%)
	Output current:	150 mA until 45°C / 80 mA by more than 45°C
Reference output:	Output voltage:	10 V
	Accuracy:	± 0.1 %
	Load:	max. 10 mA
Analog inputs:	Number of inputs:	2
	Configuration:	current or voltage operation
	Voltage input:	-10 ... +10 V (Ri ≈ 50 kOhm)
	Current input:	0 ... 20 mA / 4 ... 20 mA (Ri ≈ 100 Ohm)
	Resolution:	16 bit
	Accuracy:	± 0,1 %
Control inputs:	Number of inputs:	3
	Format:	HTL, PNP (Low 0 ... 3 V, High 9 ... 30 V)
	Frequency:	max. 10 kHz
	Load:	max. 2 mA / Ri > 15 kOhm / 470 pF
Analog output: (Option AO)	Configuration:	current or voltage operation
	Voltage output:	-10...+10 V (max. 2 mA)
	Current output:	0/4... 20 mA (burden: max. 270 Ohm)
	Resolution:	16 Bit
	Accuracy:	± 0,1 %
Control outputs: (Option CO)	Number of outputs:	4
	Format / level:	5 ... 30 V (depends on the Com+ voltage), PNP
	Output current:	max. 200 mA
	Reaction time:	< 1 ms
Relay outputs: (Option RL)	Number of outputs:	2
	Configuration:	potential free changeovers
	Switching voltage:	max. 250 VAC / 3 A / 750 VA
	Switching current:	max. 150 VDC / 2 A / 50 W
	Switching power:	max. 50 W / 250 VA
	Reaction time:	< 5 ms
Serial interface: (Option CO)	Format:	RS232
	Baudrate:	9600, 19200 or 38400 baud
Display:	Type:	LCD (backlight)
	Display range:	8 Dekaden plus Vorzeichen (-99999999 ... 99999999)
	Digit height:	13 mm
	Color:	red/ green / yellow (switchable)
	Operation:	resistive touchscreen
Housing:	Material:	ABS, UL 94 V-0
	Mounting:	panel cut out
	Dimensions (w x h x d):	96 x 48 x 116 mm / 3.78 x 1.89 x 4.56 inch
	Cut out (w x h):	91 x 43 mm / 3.58 x 1.69 inch
	Protection class:	IP65 (front), IP20 (rear)
	Weight:	approx. 200 g
Ambient temperature:	Operation:	-20 °C ... +60 °C resp. -4 ... 140 °F
	Storage:	-25 °C ... +70 °C resp. -13 ... 158 °F
Conformity and standards:	EMC 2004/108/EC:	EN 61000-6-2, EN 61000-6-3, EN 61000-6-4
	LV 2006/95/EC:	EN 61010-1
	RoHS 2011/65/EU:	EN 50581