



WPLN

The versatile right angle gearbox with spiral teeth for a quiet drive

Thanks to its spiral teeth, our **WPLN** achieves the optimal synchronism for the best surface qualities. By minimizing vibrations, it runs uniformly and quietly. The precision right angle planetary gearbox features lifetime lubrication and can be mounted virtually anywhere.

1 Highest installation flexibility

Our lifetime lubricated right angle planetary gearbox extracts the most out of little space. The **WPLN** can be installed virtually anywhere, giving you greater freedom.

2 Particularly quiet drive

The high-quality spiral teeth makes the **WPLN** a particularly low-noise solution. Additional sound absorption measures are not needed on your machine. The value of the whole system increases as a result.

3 Best surface quality

Thanks to its spiral teeth, the **WPLN** delivers a particularly uniform and low-vibration performance. Your machine therefore produces the highest surface quality and the best prints.

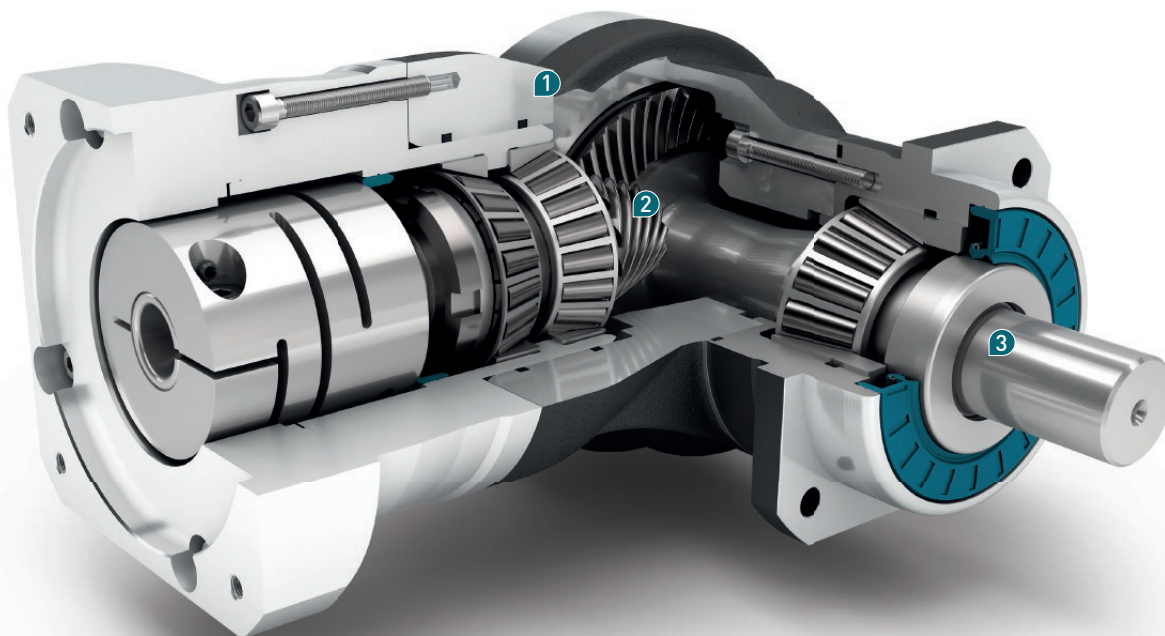

- + Individual adaptation of the input flange to the motor
- + Lifetime lubrication for maintenance-free operation
- + Counterdirectional rotation
- + Wide range of output shaft designs
- + Clamping systems with optimized mass moment of inertia

Code	Gearbox characteristics			WPLN070	WPLN090	WPLN115	WPLN142	z ⁽¹⁾
	Service life	t _L	h	20,000				
	Service life at T _{2N} × 0,88			30,000				
	Efficiency at full load ⁽²⁾	η	%	95				1
				94				2
	Min. operating temperature	T _{min}	°C (°F)	-25 (-13)				
	Max. operating temperature	T _{max}		90 (194)				
	Protection class			IP 65				
S	Standard lubrication			Oil				
F	Food grade lubrication			Oil				
	Installation position			Any				
S	Standard backlash	j _t	arcmin	< 5				
	Torsional stiffness ⁽²⁾	c _G	Nm/arcmin (lb _f .in/ arcmin)	1,8 - 2,4 (16 - 21)	4,6 - 6,2 (41 - 55)	10,1 - 13,5 (89 - 119)	25,5 - 34,0 (226 - 301)	1
				2,3 - 3,0 (20 - 27)	5,9 - 7,8 (52 - 69)	12,8 - 16,9 (113 - 150)	32,5 - 42,5 (288 - 376)	2
	Gearbox weight	m _G	kg (lb _m)	3 (6.6)	5 (11.0)	10,5 (23.2)	25 (55.1)	1
				3,9 (8.6)	5,3 (11.7)	9,2 (20.3)	21,5 (47.4)	2
S	Standard surface			Right angle housing: Aluminum – anodized (black)				
	Running noise ⁽³⁾	Q _G	dB(A)	66	67	68	70	
	Max. bending moment based on the gearbox input flange ⁽⁴⁾	M _b	Nm (lb _f .in)	12 (106)	25,5 (226)	53 (469)	120 (1062)	1
				12 (106)	12 (106)	25,5 (226)	53 (469)	2
	Motor flange precision			DIN 42955-R				

Output shaft loads			WPLN070	WPLN090	WPLN115	WPLN142	z ⁽¹⁾
Radial force for 20,000 h ⁽⁵⁾⁽⁶⁾	F _{r,20.000h}	N (lb _f)	3200 (720)	5200 (1170)	6000 (1350)	12500 (2813)	1
			3200 (720)	5500 (1238)	6000 (1350)	12500 (2813)	2
Axial force for 20,000 h ⁽⁵⁾⁽⁶⁾	F _{a,20.000h}		4300 (968)	5900 (1328)	7000 (1575)	14500 (3263)	1
			4400 (990)	6400 (1440)	8000 (1800)	15000 (3375)	2
Radial force for 30,000 h ⁽⁵⁾⁽⁶⁾	F _{r,30.000h}		3200 (720)	5200 (1170)	6000 (1350)	10900 (2453)	1
			3200 (720)	4800 (1080)	5400 (1215)	11400 (2565)	2
Axial force for 30,000 h ⁽⁵⁾⁽⁶⁾	F _{a,30.000h}		3700 (833)	5200 (1170)	6100 (1373)	12000 (2700)	1
			3900 (878)	5700 (1283)	7000 (1575)	13200 (2970)	2
Static radial force ⁽⁶⁾⁽⁷⁾	F _{r,Stat}		3200 (720)	5200 (1170)	6000 (1350)	12500 (2813)	1
			3200 (720)	5500 (1238)	6000 (1350)	12500 (2813)	2
Static axial force ⁽⁶⁾⁽⁷⁾	F _{a,Stat}	4300 (968)	5900 (1328)	7000 (1575)	14500 (3263)	1	
		4400 (990)	6400 (1440)	8000 (1800)	15000 (3375)	2	
Tilting moment for 20,000 h ⁽⁵⁾⁽⁷⁾	M _{K,20.000h}	Nm (lb _f .in)	322 (2850)	624 (5522)	1010 (8939)	2225 (19691)	1
			322 (2850)	660 (5841)	1010 (8939)	2225 (19691)	2
Tilting moment for 30,000 h ⁽⁵⁾⁽⁷⁾	M _{K,30.000h}		322 (2850)	624 (5522)	1010 (8939)	1940 (17169)	1
			322 (2850)	576 (5098)	909 (8045)	2029 (17957)	2

Moment of inertia			WPLN070	WPLN090	WPLN115	WPLN142	z ⁽¹⁾
Mass moment of inertia ⁽²⁾	J	kgcm ² (lb _f .in.s ² 10 ⁻⁴)	0.500 - 0.822 (4.425 - 7.275)	1.013 - 1.387 (8.965 - 12.275)	4.767 - 5.875 (42.188 - 51.994)	15.090 - 18.307 (133.547 - 162.017)	1
			0.498 - 0.642 (4.407 - 5.682)	0.497 - 0.649 (4.398 - 5.744)	1.014 - 1.419 (8.974 - 12.558)	4.807 - 6.387 (42.542 - 56.525)	2

(1) Number of stages
(2) The ratio-dependent values can be retrieved in Tec Data Finder – www.neugart.com
(3) Sound pressure level from 1 m, measured on input running at n₁=3000 rpm no load; i=5
(4) Max. motor weight* in kg = 0.2 × M_b / motor length in m
* with symmetrically distributed motor weight
* with horizontal and stationary mounting
(5) These values are based on an output shaft speed of n₂=100 rpm
(6) Based on center of output shaft
(7) Other (sometimes higher) values following changes to T_{2N}, F_r, F_a, cycle, and service life of bearing. Application specific configuration with NCP – www.neugart.com

Output torques			WPLN070	WPLN090	WPLN115	WPLN142	$i^{(1)}$	$z^{(2)}$		
Nominal output torque ⁽³⁾⁽⁴⁾	T_{2N}	Nm (lb.,in)	45 (398)	90 (797)	160 (1416)	320 (2832)	4	1		
			42 (372)	75 (664)	140 (1239)	280 (2478)	5			
			27 (239)	50 (443)	90 (797)	180 (1593)	8			
			22 (195)	40 (354)	75 (664)	160 (1416)	10			
			77 (681)	150 (1328)	300 (2655)	640 (5664)	16			
			77 (681)	150 (1328)	300 (2655)	800 (7080)	20			
				Nm (lb.,in)	65 (575)	140 (1239)	260 (2301)	700 (6195)	25	2
					77 (681)	108 (956)	200 (1770)	360 (3186)	32	
					65 (575)	135 (1195)	250 (2213)	450 (3983)	40	
					65 (575)	110 (974)	200 (1770)	375 (3319)	50	
					40 (354)	80 (708)	150 (1328)	450 (3983)	64	
					27 (239)	60 (531)	125 (1106)	305 (2699)	100	
Max. output torque ⁽⁴⁾⁽⁵⁾	T_{2max}	Nm (lb.,in)	72 (637)	144 (1274)	256 (2266)	512 (4531)	4	1		
			67 (593)	120 (1062)	224 (1982)	448 (3965)	5			
			43 (381)	80 (708)	144 (1274)	288 (2549)	8			
			35 (310)	64 (566)	120 (1062)	256 (2266)	10			
			123 (1089)	240 (2124)	480 (4248)	1024 (9062)	16			
			123 (1089)	240 (2124)	480 (4248)	1280 (11328)	20			
				Nm (lb.,in)	104 (920)	224 (1982)	416 (3682)	1120 (9912)	25	2
					123 (1089)	172 (1522)	320 (2832)	576 (5098)	32	
					104 (920)	216 (1912)	400 (3540)	720 (6372)	40	
					104 (920)	176 (1558)	320 (2832)	600 (5310)	50	
					64 (566)	128 (1133)	240 (2124)	720 (6372)	64	
					43 (381)	96 (850)	200 (1770)	488 (4319)	100	

(1) Ratios ($i=n_1/n_2$)
 (2) Number of stages
 (3) Application specific configuration with NCP – www.neugart.com
 (4) Values for feather key (code "A"): for repeated load
 (5) 30,000 rotations of the output shaft permitted; see page 136

Output torques			WPLN070	WPLN090	WPLN115	WPLN142	$i^{(1)}$	$z^{(2)}$		
Emergency stop torque ⁽³⁾	T_{2Stop}	Nm (lb _f .in)	100 (885)	200 (1770)	400 (3540)	800 (7080)	4	1		
			100 (885)	200 (1770)	400 (3540)	800 (7080)	5			
			75 (664)	150 (1328)	300 (2655)	700 (6195)	8			
			75 (664)	150 (1328)	300 (2655)	700 (6195)	10			
			150 (1328)	300 (2655)	650 (5753)	1600 (14160)	16			
			150 (1328)	300 (2655)	650 (5753)	1600 (14160)	20			
					150 (1328)	300 (2655)	650 (5753)	1600 (14160)	25	2
					150 (1328)	300 (2655)	600 (5310)	1200 (10620)	32	
					150 (1328)	300 (2655)	650 (5753)	1500 (13275)	40	
					150 (1328)	300 (2655)	600 (5310)	1200 (10620)	50	
					80 (708)	200 (1770)	380 (3363)	1000 (8850)	64	
					80 (708)	200 (1770)	480 (4248)	750 (6638)	100	

Input speeds			WPLN070	WPLN090	WPLN115	WPLN142	$i^{(1)}$	$z^{(2)}$		
Average thermal input speed at T_{2N} and S1 ⁽⁴⁾⁽⁵⁾	n_{1N}	rpm	1800 ⁽⁶⁾	1650 ⁽⁶⁾	1150 ⁽⁶⁾	950 ⁽⁶⁾	4	1		
			2000 ⁽⁶⁾	1900 ⁽⁶⁾	1250 ⁽⁶⁾	1000 ⁽⁶⁾	5			
			2350 ⁽⁶⁾	2250 ⁽⁶⁾	1450 ⁽⁶⁾	1100 ⁽⁶⁾	8			
			2500 ⁽⁶⁾	2400 ⁽⁶⁾	1500 ⁽⁶⁾	1100 ⁽⁶⁾	10			
			1850 ⁽⁶⁾	1800 ⁽⁶⁾	1650 ⁽⁶⁾	1000 ⁽⁶⁾	16			
			2000 ⁽⁶⁾	2100 ⁽⁶⁾	1950 ⁽⁶⁾	1050 ⁽⁶⁾	20			
					2150 ⁽⁶⁾	2250 ⁽⁶⁾	2150 ⁽⁶⁾	1150 ⁽⁶⁾	25	2
					2300 ⁽⁶⁾	2300 ⁽⁶⁾	2200 ⁽⁶⁾	1400 ⁽⁶⁾	32	
					2400 ⁽⁶⁾	2300 ⁽⁶⁾	2250 ⁽⁶⁾	1450 ⁽⁶⁾	40	
					2500 ⁽⁶⁾	2450 ⁽⁶⁾	2400 ⁽⁶⁾	1550 ⁽⁶⁾	50	
					2600 ⁽⁶⁾	2950 ⁽⁶⁾	2850 ⁽⁶⁾	1750 ⁽⁶⁾	64	
					2700 ⁽⁶⁾	3100 ⁽⁶⁾	3050 ⁽⁶⁾	1900 ⁽⁶⁾	100	
Max. mechanical input speed ⁽⁴⁾	n_{1Limit}	rpm	16000	14000	9500	8000		1		
			16000	16000	14000	9500		2		

⁽¹⁾ Ratios ($i=n_1/n_2$)

⁽²⁾ Number of stages

⁽³⁾ Permitted 1000 times

⁽⁴⁾ Application-specific speed configurations with NCP – www.neugart.com
⁽⁵⁾ See page 136 for the definition

⁽⁶⁾ Average thermal input speed at 50% T_{2N} and S1

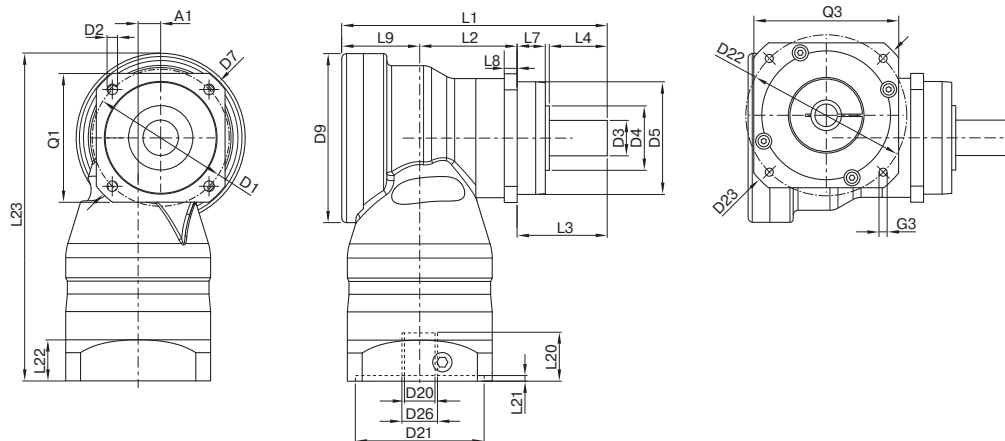

Drawing corresponds to a WPLN090 / 1-stage / smooth output shaft / 19 mm clamping system / motor adaptation – 2-part – round universal flange / B5 flange type motor
 All other variants can be retrieved in the Tec Data Finder at www.neugart.com

Geometry ⁽¹⁾			WPLN070	WPLN090	WPLN115	WPLN142	z ⁽²⁾	Code
Axis offset	A1		10 (0.394)	14 (0.551)	20 (0.787)	26 (1.024)	1	
			10 (0.394)	10 (0.394)	14 (0.551)	20 (0.787)	2	
Pitch circle diameter output	D1		68 - 75 (2.677 - 2.953)	85 (3.346)	120 (4.724)	165 (6.496)		
Mounting bore output	D2	4x	5.5 (0.217)	6.5 (0.256)	9.0 (0.354)	11.0 (0.433)		
Shaft diameter output	D3	k6	16 (0.630)	22 (0.866)	32 (1.260)	40 (1.575)		
Shaft collar output	D4		30 (1.181)	40 (1.575)	45 (1.772)	70 (2.756)	1	
			35 (1.378)	40 (1.575)	45 (1.772)	70 (2.756)	2	
Centering diameter output	D5	g7	60 (2.362)	70 (2.756)	90 (3.543)	130 (5.118)		
Diagonal dimension output	D7		92 (3.622)	100 (3.937)	140 (5.512)	185 (7.283)		
Max. diameter	D9		86 (3.386)	105 (4.134)	120 (4.724)	170 (6.693)	1	
			86 (3.386)	86 (3.386)	105 (4.134)	120 (4.724)	2	
Flange cross section output	Q1	■	70 (2.756)	80 (3.150)	110 (4.331)	142 (5.591)		
Total length	L1		137.5 (5.413)	165 (6.496)	218 (8.583)	273 (10.748)	1	
			185 (7.283)	207 (8.150)	248.5 (9.783)	342.5 (13.484)	2	
Housing length	L2		46.5 (1.831)	60.5 (2.382)	73.5 (2.894)	76 (2.992)	1	
			94 (3.701)	108 (4.252)	112 (4.409)	176 (6.929)	2	
Shaft length output	L3		48 (1.890)	56 (2.205)	88 (3.465)	110 (4.331)		
Centering depth output	L7		18 (0.709)	17.5 (0.689)	28 (1.102)	28 (1.102)		
Flange thickness output	L8		7 (0.276)	8 (0.315)	10 (0.394)	12 (0.472)		
Offset length	L9		43 (1.693)	48.5 (1.909)	56.5 (2.224)	87 (3.425)	1	
			43 (1.693)	43 (1.693)	48.5 (1.909)	56.5 (2.224)	2	
Min. overall height	L23		179.0 (7.047)	203.5 (8.012)	247.5 (9.744)	318.0 (12.520)	1	
			179.0 (7.047)	182.5 (7.185)	210.0 (8.268)	258.5 (10.177)	2	
Clamping system diameter input	D26		More information on page 125					
Motor shaft diameter j6/k6	D20							
Max. permis. motor shaft length	L20							
Min. permis. motor shaft length								
Centering diameter input	D21							
Centering depth input	L21							
Pitch circle diameter input	D22							
Motor flange length	L22							
Diagonal dimension input	D23							
Mounting thread x depth	G3	4x						
Flange cross section input	Q3	■						
Output shaft with feather key (DIN 6885-1)			A 5x5x25	A 6x6x28	A 10x8x50	A 12x8x65		A
Feather key width (DIN 6885-1)	B1		5 (0.197)	6 (0.236)	10 (0.394)	12 (0.472)		
Shaft height including feather key (DIN 6885-1)	H1		18 (0.709)	24.5 (0.965)	35 (1.378)	43 (1.693)		
Shaft length from shoulder	L4		28 (1.102)	36 (1.417)	58 (2.283)	80 (3.150)		
Feather key length	L5		25 (0.984)	28 (1.102)	50 (1.969)	65 (2.559)		
Distance from shaft end	L6		2 (0.079)	4 (0.157)	4 (0.157)	8 (0.315)		
Center hole (DIN 332, type DR)	Z		M5x12.5	M8x19	M12x28	M16x36		
Smooth output shaft								B
Shaft length from shoulder	L4		28 (1.102)	36 (1.417)	58 (2.283)	80 (3.150)		

The dimensions vary with the motor/gearbox flange.
 The input flange geometries can be retrieved for each specific motor in Tec Data Finder at www.neugart.com

⁽¹⁾ Dimensions in mm (in)
⁽²⁾ Number of stages