



Center Distance

$a_o = 63 \text{ mm}$

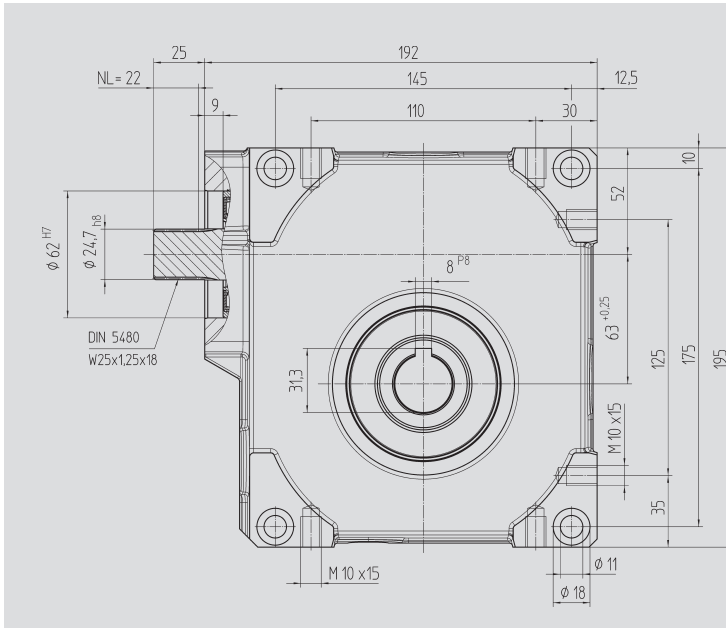

Fig. 1 Output shaft with key connection

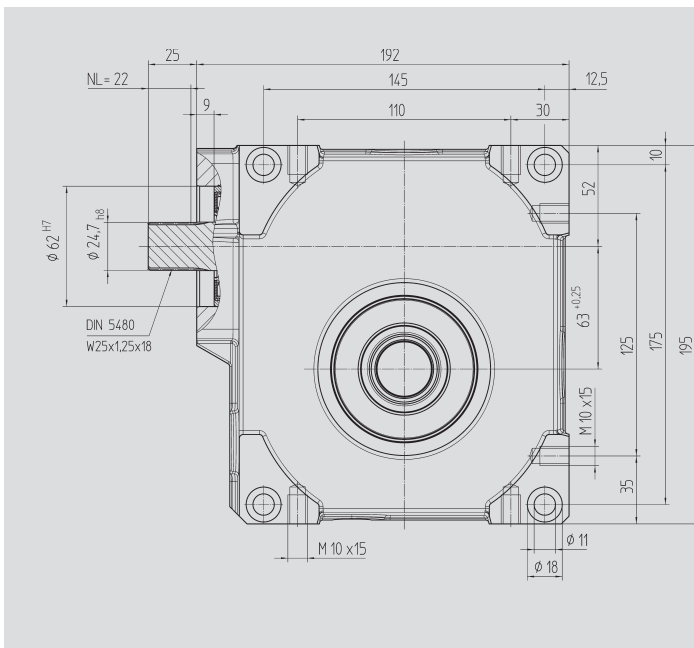
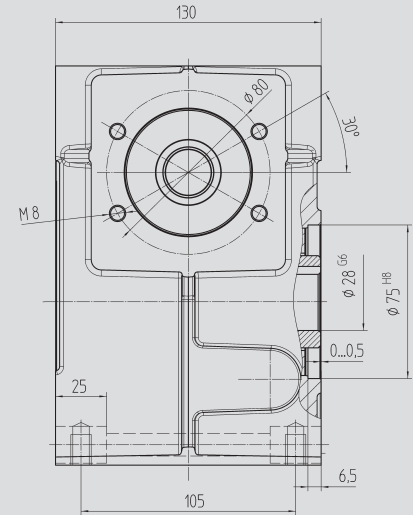
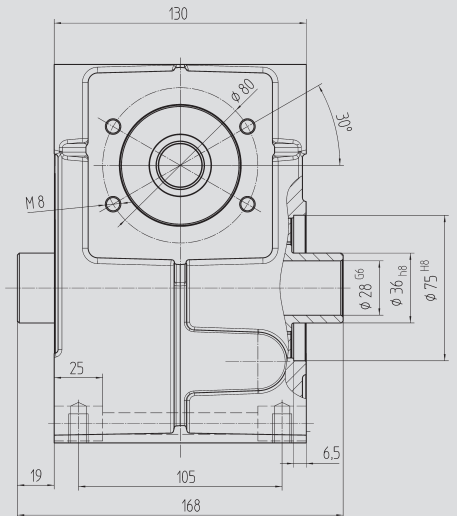

Fig. 2 Output shaft for clamp connection 80 84 136



Order Code
Fig. 1

Fig. 2

Ratio i



J_{red} 10⁻⁴
kg m²

59 04 005	59 14 005	4.75	11.5	2.5350
59 04 007	59 14 007	6.75	11.5	1.3720
59 04 009	59 14 009	9.25	11.5	0.9825
59 04 015	59 14 015	14.50	11.5	0.9590
59 04 020	59 14 020	19.50	11.5	0.6940
59 04 029	59 14 029	29.00	11.5	0.9966
59 04 039	59 14 039	39.00	11.5	1.0100
59 04 052	59 14 052	52.00	11.5	0.5305

With food grade oil, order code 59 04 1xx / 59 14 1xx



Motor Flange

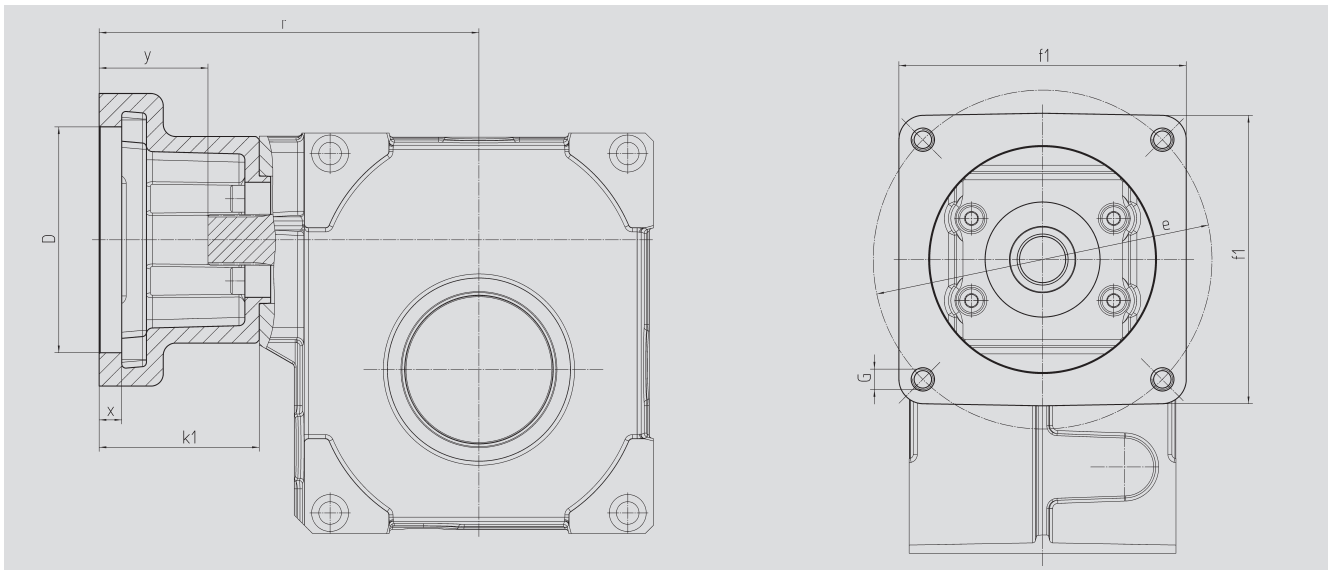

Center Distance

$a_o = 63 \text{ mm}$

Order Code	D ^{G7}	k ₁	r	x	y	f ₁	e	G	kg
65 59 301	95.0	62	169	12.5	42	100	115	M8	0.60
65 59 302	50.0	62	169	10.0	42	100	70, 95, 115	M4, M6, M8	0.70
65 59 303	80.0	62	169	10.0	42	100	100	M6	0.65
65 59 304	95.0	78	185	10.0	59	115	130	M8	0.80
65 59 305	95.0	72	179	8.0	52	100	115	M8	0.75
65 59 306	60.0	74	181	21.0	54	100	75, 90, 115	M5, M5, M8	0.90
65 59 307	70.0	70	177	21.0	50	100	90, 115	M6, M8	0.80
65 59 401	95.0	73	180	8.0	53	100	115	M8	0.75
65 59 402	110.0	78	185	8.0	59	115	130	M8	0.80
65 59 403	95.0	73	180	12.0	53	115	130	M8	0.75
65 59 404	110.0	73	180	12.0	53	115	130	M8	0.70
65 59 405	95.0	78	185	11.0	59	140	165	M10	1.20
65 59 406	110.0	78	185	11.0	59	140	165	M10	1.15
65 59 407	130.0	78	185	11.0	59	140	165	M10	1.00
65 59 409	130.0	98	205	14.0	78	140	165	M10	1.10
65 59 410	110.0	74	181	8.0	54	120	145	M8	1.00
65 59 411	110.0	84	191	8.0	64	120	145	M8	1.20
65 59 412	114.3	105	212	8.0	85	180	200	M12	3.70
65 59 413	114.3	139	246	8.0	119	180	200	M12	3.35
65 59 414	114.3	91	198	8.0	71	180	200	M12	2.65
65 59 415	110.0	89	196	8.0	69	120	145	M8	1.30

The order should contain gear box 59 04 0xx / 59 14 0xx and flange 65 59 3xx or 4xx.