



Passfederverbindung / Key connection

Baugröße / Construction-size

BG 50

5 Anschraubflächen / 5 Mounting surfaces

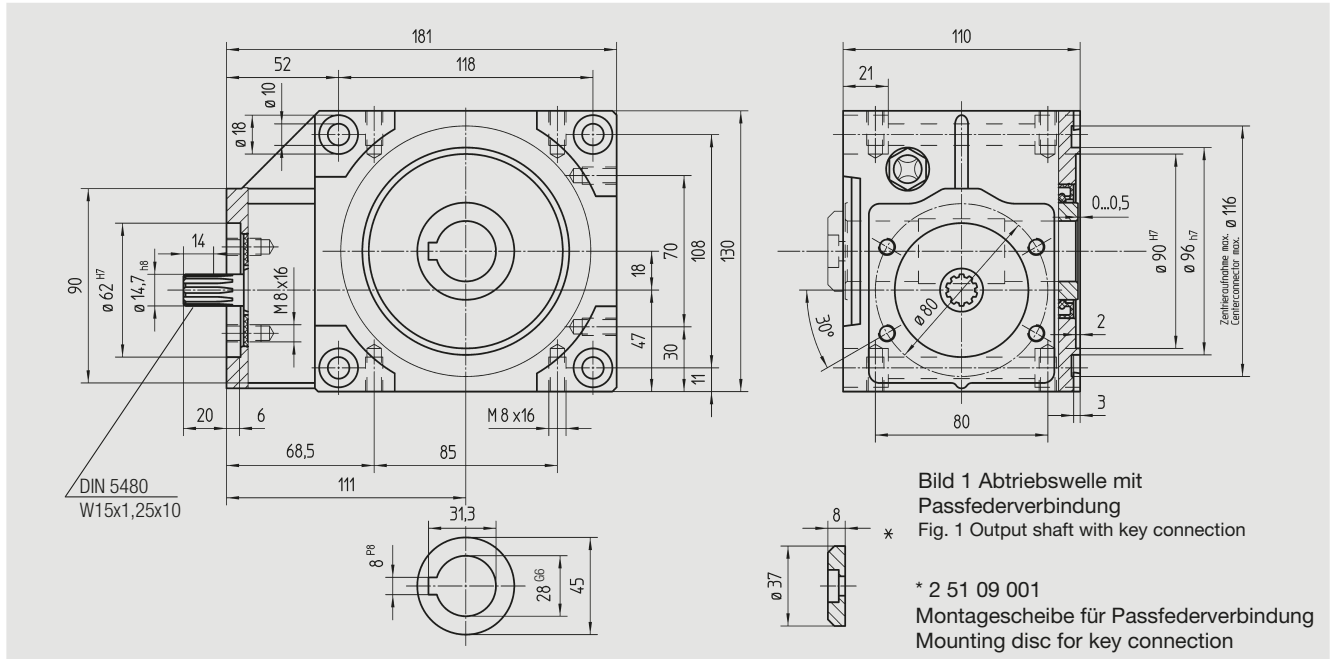

Klemmverbindung / Shrink-disc connection

Baugröße / Construction-size

BG 50

5 Anschraubflächen / 5 Mounting surfaces

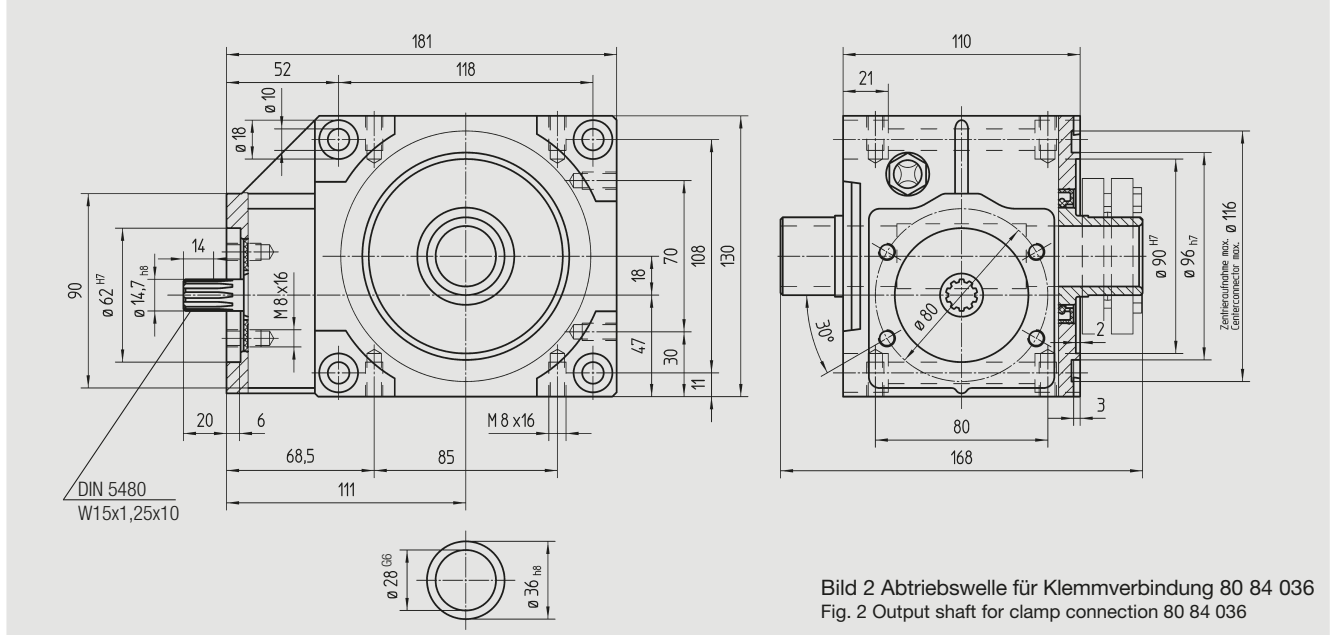

Bestell-Nr. 5 Anschlagflächen

Order-Code 5 Mounting surfaces

Übersetzung i

Ratio i



$J_{red} 10^{-4}$
kg m²

Passfederverbindung **Klemmverbindung**
Key connection Shrink-disc connection

51 03 005	51 13 005	4,75	6,4	0,820
51 03 007	51 13 007	6,75	6,4	0,551
51 03 009	51 13 009	9,25	6,4	0,406

* Erforderlich zur Montage ATLANTA Ritzelwellen 20 2x 4xx oder Abtriebswellen 65 04 xxx / Necessary for mounting of ATLANTA Pinion 20 2x 4xx or Output drive shaft 65 04 xxx.