

SIEMENS

SINAMICS

SINAMICS S120

Drive functions

Function Manual

Edition

07/2016

SIEMENS

SINAMICS

S120 Drive functions

Function Manual

Valid as of:
Firmware version 4.8



(FH1), 07/2016
6SL3097-4AB00-0BP5

Preface	
Fundamental safety instructions	1
Infeed	2
Extended setpoint channel	3
Servo control	4
Vector control	5
U/f control (vector control)	6
Basic functions	7
Function modules	8
Monitoring functions and protective functions	9
Safety Integrated Basic Functions	10
Communication	11
Applications	12
Basic information about the drive system	13
Appendix	A

Legal information

Warning notice system

This manual contains notices you have to observe in order to ensure your personal safety, as well as to prevent damage to property. The notices referring to your personal safety are highlighted in the manual by a safety alert symbol, notices referring only to property damage have no safety alert symbol. These notices shown below are graded according to the degree of danger.

 DANGER
indicates that death or severe personal injury will result if proper precautions are not taken.
 WARNING
indicates that death or severe personal injury may result if proper precautions are not taken.
 CAUTION
indicates that minor personal injury can result if proper precautions are not taken.
NOTICE
indicates that property damage can result if proper precautions are not taken.

If more than one degree of danger is present, the warning notice representing the highest degree of danger will be used. A notice warning of injury to persons with a safety alert symbol may also include a warning relating to property damage.

Qualified Personnel

The product/system described in this documentation may be operated only by **personnel qualified** for the specific task in accordance with the relevant documentation, in particular its warning notices and safety instructions. Qualified personnel are those who, based on their training and experience, are capable of identifying risks and avoiding potential hazards when working with these products/systems.

Proper use of Siemens products

Note the following:

 WARNING
Siemens products may only be used for the applications described in the catalog and in the relevant technical documentation. If products and components from other manufacturers are used, these must be recommended or approved by Siemens. Proper transport, storage, installation, assembly, commissioning, operation and maintenance are required to ensure that the products operate safely and without any problems. The permissible ambient conditions must be complied with. The information in the relevant documentation must be observed.

Trademarks

All names identified by ® are registered trademarks of Siemens AG. The remaining trademarks in this publication may be trademarks whose use by third parties for their own purposes could violate the rights of the owner.

Disclaimer of Liability

We have reviewed the contents of this publication to ensure consistency with the hardware and software described. Since variance cannot be precluded entirely, we cannot guarantee full consistency. However, the information in this publication is reviewed regularly and any necessary corrections are included in subsequent editions.

Preface

SINAMICS documentation

The SINAMICS documentation is organized in the following categories:

- General documentation/catalogs
- User documentation
- Manufacturer/service documentation

Additional information

You can find information on the following topics at the following address (<https://support.industry.siemens.com/cs/de/en/view/108993276>):

- Ordering documentation/overview of documentation
- Additional links to download documents
- Using documentation online (find and search in manuals/information)

Please send any questions about the technical documentation (e.g. suggestions for improvement, corrections) to the following e-mail address (<mailto:docu.motioncontrol@siemens.com>).

Siemens MySupport/Documentation

At the following address (<https://support.industry.siemens.com/My/ww/en/documentation>), you can find information on how to create your own individual documentation based on Siemens' content, and adapt it for your own machine documentation.

Training

At the following address (<http://www.siemens.com/sitrain>), you can find information about SITRAIN (Siemens training on products, systems and solutions for automation and drives).

FAQs

You can find Frequently Asked Questions in the Service&Support pages under Product Support (<https://support.industry.siemens.com/cs/de/en/ps/faq>).

SINAMICS

You can find information about SINAMICS at the following address (<http://www.siemens.com/sinamics>).

Usage phases and their documents/tools (as an example)

Table 1 Usage phases and the available documents/tools

Usage phase	Document/tool
Orientation	SINAMICS S Sales Documentation
Planning/configuration	<ul style="list-style-type: none"> • SIZER Engineering Tool • Configuration Manuals, Motors
Deciding/ordering	SINAMICS S120 catalogs <ul style="list-style-type: none"> • SIMOTION, SINAMICS S120 and Motors for Production Machines (Catalog PM 21) • SINAMICS and Motors for Single-axis Drives (Catalog D 31) • SINUMERIK & SINAMICS Equipment for Machine Tools (Catalog NC 61) • SINUMERIK 840D sl Type 1B Equipment for Machine Tools (Catalog NC 62)
Installation/assembly	<ul style="list-style-type: none"> • SINAMICS S120 Manual for Control Units and Additional System Components • SINAMICS S120 Manual for Booksize Power Units • SINAMICS S120 Manual for Booksize Power Units C/D Type • SINAMICS S120 Manual for Chassis Power Units, Air-cooled • SINAMICS S120 Manual for Chassis Power Units, Liquid-cooled • SINAMICS S120 Manual for AC Drives • SINAMICS S120 Manual Combi • SINAMICS S120M Manual Distributed Drive Technology • SINAMICS HLA System Manual Hydraulic Drive
Commissioning	<ul style="list-style-type: none"> • STARTER Commissioning Tool • SINAMICS S120 Getting Started with STARTER • SINAMICS S120 Commissioning Manual with STARTER • SINAMICS S120 CANopen Commissioning Manual • SINAMICS S120 Function Manual Drive Functions • SINAMICS S120 Safety Integrated Function Manual • SINAMICS S120/S150 List Manual • SINAMICS HLA System Manual Hydraulic Drive • Startdrive commissioning tool¹⁾ • SINAMICS S120 Getting Started with Startdrive¹⁾ • SINAMICS S120 Commissioning Manual with Startdrive¹⁾
Usage/operation	<ul style="list-style-type: none"> • SINAMICS S120 Commissioning Manual with STARTER • SINAMICS S120/S150 List Manual • SINAMICS HLA System Manual Hydraulic Drive • SINAMICS S120 Commissioning Manual with Startdrive¹⁾

Usage phase	Document/tool
Maintenance/servicing	<ul style="list-style-type: none"> • SINAMICS S120 Commissioning Manual with STARTER • SINAMICS S120/S150 List Manual • SINAMICS S120 Commissioning Manual with Startdrive¹⁾
References	<ul style="list-style-type: none"> • SINAMICS S120/S150 List Manual

¹⁾ available as of Startdrive V14 release

Target group

This documentation is intended for machine manufacturers, commissioning engineers, and service personnel who use the SINAMICS drive system.

Benefits

This manual provides all of the information, procedures and operator actions required for the particular usage phase.

Standard scope

The scope of the functionality described in this document can differ from that of the drive system that is actually supplied.

- Other functions not described in this documentation might be able to be executed in the drive system. However, no claim can be made regarding the availability of these functions when the equipment is first supplied or in the event of service.
- The documentation can also contain descriptions of functions that are not available in a particular product version of the drive system. The functionality of the supplied drive system should only be taken from the ordering documentation.
- Extensions or changes made by the machine manufacturer must be documented by the machine manufacturer.

For reasons of clarity, this documentation does not contain all of the detailed information on all of the product types, and cannot take into consideration every conceivable type of installation, operation and service/maintenance.

Technical Support

Country-specific telephone numbers for technical support are provided in the Internet at the following address (<https://support.industry.siemens.com/sc/ww/en/sc/2090>) in the "Contact" area.

Notation

The following notation and abbreviations are used in this documentation:

Notation for faults and alarms (examples):

- F12345 Fault 12345
- A67890 Alarm 67890
- C23456 Safety message

Notation for parameters (examples):

- p0918 Adjustable parameter 918
- r1024 Display parameter 1024
- p1070[1] Adjustable parameter 1070, index 1
- p2098[1].3 Adjustable parameter 2098, index 1 bit 3
- p0099[0...3] Adjustable parameter 99, indices 0 to 3
- r0945[2](3) Display parameter 945, index 2 of drive object 3
- p0795.4 Adjustable parameter 795, bit 4

Contents

	Preface	5
1	Fundamental safety instructions	23
1.1	General safety instructions	23
1.2	Industrial security	24
2	Infeed	25
2.1	Active Infeed	26
2.1.1	Active Infeed closed-loop control booksize	27
2.1.2	Active Infeed closed-loop control chassis	29
2.1.3	Line supply and DC link identification	31
2.1.4	Active Infeed open-loop control	32
2.1.5	Reactive current control	34
2.1.6	Harmonics controller	35
2.1.7	Parameterizable bandstop filters for Active Infeed Controls in chassis format	36
2.1.8	Function diagrams and parameters	37
2.2	Smart Infeed	39
2.2.1	Line supply and DC link identification routine for Smart Infeed Booksize	41
2.2.2	Extended Smart Mode	42
2.2.3	Smart Infeed open-loop control	42
2.2.4	Function diagrams and parameters	45
2.3	Basic Infeed	46
2.3.1	Basic Infeed open-loop control	49
2.3.2	Function diagrams and parameters	51
2.4	Line contactor control	52
2.5	Precharging and bypass contactor chassis	54
3	Extended setpoint channel	55
3.1	Fundamentals	55
3.1.1	Activating the function module for servo control	55
3.1.2	Description	56
3.2	Motorized potentiometer	58
3.3	Fixed setpoints	60
3.4	Speed setpoint	61
3.4.1	Main/supplementary setpoint and setpoint scaling	61
3.4.2	Jogging	62
3.4.3	Direction of rotation limiting and direction reversal	67
3.5	Speed limiting	68
3.6	Ramp-function generator	70
3.6.1	Ramp-function generator tracking	73
3.6.2	Signal overview, function diagrams and important parameters	75

4	Servo control	77
4.1	Setpoint addition	81
4.2	Speed setpoint filter	83
4.3	Speed controller	85
4.3.1	Speed controller	85
4.3.2	Speed controller adaptation	86
4.3.3	Torque-controlled operation	88
4.4	Torque setpoint limitation	91
4.5	Current setpoint filter	96
4.5.1	Lowpass 2nd order (PT2 filter)	98
4.5.2	Bandstop with infinite notch depth	99
4.5.3	Bandstop with defined notch depth	100
4.5.4	Bandstop with defined reduction	101
4.5.5	General low-pass with reduction	102
4.5.6	Transfer function general 2nd order filter	103
4.5.7	Function diagrams and parameters	103
4.6	Current controller	105
4.7	Autotuning	108
4.7.1	One button tuning	109
4.7.2	Online tuning	113
4.7.2.1	"Drive-based" online tuning	113
4.7.2.2	Automatic pre-assignment and adaptation during operation	116
4.7.2.3	Application examples	118
4.7.2.4	Problem handling	119
4.7.3	Current setpoint filter adaptation	120
4.7.3.1	Activating/deactivating the current setpoint filter adaptation	120
4.7.3.2	Principle of operation of the current setpoint filter adaptation	122
4.7.3.3	Stability of the speed control loop	124
4.7.3.4	Lower and upper limit frequencies	125
4.7.3.5	Remedy for insufficient adaptation	125
4.7.4	Function diagrams and parameters	126
4.8	Note about the electronic motor model	127
4.9	V/f control	128
4.10	Optimizing the current and speed controller	133
4.11	Encoderless operation	135
4.12	Motor data identification	141
4.12.1	Motor data identification induction motor	145
4.12.2	Motor data identification synchronous motor	147
4.13	Pole position identification	151
4.13.1	Notes regarding pole position identification	152
4.13.2	Pole position identification technique	155
4.13.3	Commutation angle offset commissioning support (p1990)	156
4.13.4	Overview of important parameters (see SINAMICS S120/S150 List Manual)	157
4.14	Vdc control	159
4.15	Dynamic Servo Control (DSC)	163

4.16	Travel to fixed stop.....	168
4.17	Vertical axes	173
4.18	Variable signaling function.....	174
4.19	Central probe evaluation.....	176
4.19.1	Examples	183
4.19.2	Function diagrams and parameters	185
5	Vector control.....	187
5.1	Vector control without encoder (SLVC)	191
5.2	Vector control with encoder	200
5.3	Synchronous reluctance motors without damping cage	201
5.4	Speed controller	203
5.4.1	Speed controller	203
5.4.2	Speed controller adaptation	206
5.4.3	Speed controller precontrol and reference model	209
5.5	Droop	213
5.6	Open actual speed value	215
5.7	Closed-loop torque control.....	217
5.8	Torque limiting	220
5.9	Vdc control	222
5.10	Current setpoint filter.....	227
5.11	Speed actual value filter	229
5.12	Current controller adaptation	230
5.13	Motor data identification and rotating measurement	232
5.13.1	Overview	232
5.13.2	Motor data identification.....	234
5.13.3	Rotating measurement.....	237
5.13.4	Shortened rotating measurement	239
5.13.5	Overview of important parameters.....	240
5.14	Efficiency optimization	241
5.15	Fast magnetization for induction motors.....	243
5.16	Flying restart	247
5.16.1	Fast flying restart	250
5.16.2	Flying restart for a reluctance motor	251
5.16.3	Messages and parameters	252
5.17	Synchronization	253
5.18	Voltage Sensing Module	255
5.19	Simulation mode	257
5.20	Redundancy mode power units	258
5.21	Bypass	259
5.21.1	Overview	259

5.21.2	Bypass with synchronization with overlap	261
5.21.3	Bypass with synchronization without overlap	263
5.21.4	Bypass without synchronization.....	266
5.21.5	Function diagrams and parameters	268
5.22	Asynchronous pulse frequency.....	269
6	U/f control (vector control).....	273
6.1	Voltage boost	277
6.2	Slip compensation.....	281
6.3	Resonance damping	282
6.4	Vdc control	283
7	Basic functions.....	289
7.1	Switching over units	289
7.2	Reference parameters/scaling	291
7.3	Configuring the short-circuit/ground fault test mode	296
7.4	Modular machine concept.....	297
7.5	Sine-wave filter.....	300
7.6	Motor reactors	302
7.7	dv/dt filter plus Voltage Peak Limiter	304
7.8	dv/dt filter compact plus Voltage Peak Limiter.....	305
7.9	Pulse frequency wobbling	307
7.10	Direction reversal without changing the setpoint	308
7.11	Automatic restart.....	310
7.12	Armature short-circuit, DC braking.....	313
7.12.1	Armature short-circuit braking for permanent-magnet synchronous motors	314
7.12.1.1	Internal armature short-circuit braking	314
7.12.1.2	External armature short-circuit braking.....	315
7.12.2	DC braking	318
7.12.2.1	Activation via parameters.....	318
7.12.2.2	Activation via fault response	319
7.12.2.3	Activation via OFF fault responses	320
7.12.2.4	Activation via a speed threshold	320
7.12.3	Configuring the fault response.....	321
7.12.4	Function diagrams and parameters	322
7.13	Motor Module as a Braking Module	323
7.13.1	Features	323
7.13.2	Configuring resistors	323
7.13.3	Activating the "Braking Module" function	328
7.13.4	Protective equipment	330
7.13.5	Overview of the important parameters.....	331
7.14	OFF3 torque limits.....	332
7.15	Technology function friction characteristic.....	333

7.16	Simple brake control	335
7.17	Runtime (operating hours counter)	338
7.18	Energy-saving display	340
7.19	Encoder diagnostics	344
7.19.1	Datalogger	344
7.19.2	Encoder dirty signal	345
7.20	Tolerant encoder monitoring	346
7.20.1	Encoder track monitoring	348
7.20.2	Zero mark tolerance	349
7.20.3	Freezing the speed raw value	349
7.20.4	Adjustable hardware filter	350
7.20.5	Edge evaluation of the zero mark	351
7.20.6	Pole position adaptation	352
7.20.7	Pulse number correction for faults	353
7.20.8	"Tolerance band pulse number" monitoring	354
7.20.9	Signal edge evaluation (1x, 4x)	355
7.20.10	Setting the measuring time to evaluate speed "0"	356
7.20.11	Sliding averaging of the speed actual value	356
7.20.12	Troubleshooting	357
7.20.13	Tolerance window and correction	359
7.20.14	Dependencies	360
7.20.15	Overview of important parameters	362
7.21	Parking axis and parking encoder	363
7.22	Position tracking	366
7.22.1	General information	366
7.22.2	Measuring gearbox	368
7.23	Creating an encoder as drive object	372
7.23.1	Preconditions for creating an ENCODER drive object using STARTER	372
7.23.2	Creating an ENCODER drive object	373
7.24	Terminal Module 41	374
7.24.1	SIMOTION mode	374
7.24.2	SINAMICS mode	375
7.24.3	Zero mark emulation (SINAMICS mode)	377
7.24.4	Synchronization of the zero marks (SINAMICS mode)	380
7.24.5	Limit frequencies for TM41	381
7.24.6	Example in the SINAMICS mode	382
7.24.7	Function diagrams and parameters	383
7.25	Upgrade the firmware and project	385
7.25.1	Overview	385
7.25.2	Updating the firmware via the Web server	386
7.25.2.1	Overview	386
7.25.2.2	Updating firmware/configuration on the memory card	387
7.25.3	Updating the firmware	390
7.25.4	Downgrade lock	392
7.25.5	Protection against power failure while updating via the Web server	392
7.26	Pulse/direction interface	393
7.27	Derating function for chassis units	395

7.28	Parallel connection of motors.....	396
7.29	Web server.....	399
7.29.1	Overview.....	399
7.29.2	Requirements and addressing.....	400
7.29.3	Configuring the Web server.....	401
7.29.3.1	Performing the basic configuration.....	401
7.29.3.2	Assigning a password.....	403
7.29.4	Access protection and rights.....	406
7.29.4.1	SINAMICS access protection.....	406
7.29.4.2	Web server access protection.....	407
7.29.4.3	Access protection for parameter lists in the web server.....	409
7.29.5	Starting the Web server.....	410
7.29.6	Displaying device information.....	414
7.29.7	Displaying diagnostic functions.....	415
7.29.7.1	Status and operating display of the drive object.....	415
7.29.7.2	Loading a multiple trace.....	415
7.29.8	Displaying messages.....	417
7.29.8.1	Displaying the diagnostic buffer.....	417
7.29.8.2	Displaying faults and alarms.....	418
7.29.9	Displaying and changing drive parameters.....	419
7.29.9.1	Creating a parameter list.....	419
7.29.9.2	Deleting a parameter list.....	422
7.29.9.3	Displaying and changing drive parameters.....	424
7.29.10	Updating the firmware or configuration.....	427
7.29.11	Certificates for the secure data transfer.....	428
7.29.11.1	Overview.....	428
7.29.11.2	Using the certificate default configuration.....	430
7.29.11.3	Generating your own certificates.....	431
7.29.12	Messages and parameters.....	432
8	Function modules.....	433
8.1	Technology controller.....	435
8.2	Extended monitoring functions.....	440
8.3	Extended Brake Control.....	442
8.4	Braking Module External.....	448
8.5	Cooling unit.....	450
8.6	Extended torque control (kT estimator, servo).....	452
8.7	Position control.....	454
8.7.1	General features.....	454
8.7.2	Position actual value conditioning.....	454
8.7.2.1	Features.....	454
8.7.2.2	Description.....	454
8.7.2.3	Indexed actual value acquisition.....	458
8.7.2.4	Load gear position tracking.....	459
8.7.2.5	Commissioning position tracking load gear using STARTER.....	466
8.7.2.6	Function diagrams and parameters.....	467
8.7.3	Position controller.....	468
8.7.4	Monitoring functions.....	469
8.7.5	Measuring probe evaluation and reference mark search.....	472

8.7.6	Commissioning	473
8.8	Basic positioner.....	474
8.8.1	Mechanical system	476
8.8.2	Limits.....	478
8.8.3	EPOS and safe setpoint velocity limitation	483
8.8.4	Referencing.....	483
8.8.4.1	Function diagrams and parameters	493
8.8.5	Referencing with several zero marks per revolution.....	493
8.8.6	Safely referencing under EPOS.....	498
8.8.7	Traversing blocks.....	501
8.8.8	Travel to fixed stop.....	507
8.8.9	Direct setpoint input (MDI)	510
8.8.10	Jog	513
8.8.11	Status signals.....	514
8.9	Master/slave function for Active Infeed.....	516
8.9.1	Operating principle.....	516
8.9.2	Basic structure	517
8.9.3	Types of communication.....	520
8.9.4	Description of functions.....	521
8.9.5	Commissioning	524
8.9.6	Function diagrams and parameters	525
8.10	Parallel connection of power units	526
8.10.1	Applications of parallel connections.....	528
8.10.1.1	Parallel connection of Basic Line Modules	530
8.10.1.2	Parallel connection of Smart Line Modules	532
8.10.1.3	Parallel connection of Active Line Modules	533
8.10.1.4	Parallel connection of Motor Modules.....	534
8.10.2	Commissioning	536
8.10.3	Additional drive in addition to the parallel connection.....	537
8.11	Extended stop and retract.....	540
8.11.1	Activating and enabling the ESR function module.....	541
8.11.2	Valid sources for triggering the ESR functions	542
8.11.3	Invalid sources	543
8.11.4	ESR responses	543
8.11.4.1	Extended stopping	543
8.11.4.2	Extended retract.....	544
8.11.4.3	Regenerative operation.....	545
8.11.5	Restrictions for ESR.....	545
8.11.6	PROFIdrive telegram for ESR	546
8.11.7	Function diagrams and parameters.....	547
8.12	Moment of inertia estimator	548
8.12.1	Introduction	548
8.12.2	Commissioning	552
8.12.3	Supplementary functions of the moment of inertia estimator for vector control	553
8.12.4	Function diagrams and parameters.....	554
8.13	Additional controls for Active Infeed	556
8.14	Advanced Position Control	557
8.14.1	Introduction	557
8.14.2	Commissioning the function module.....	560

8.14.3	APC without sensor on the load side	562
8.14.4	APC with encoder combination and differential position feedback:.....	568
8.14.5	APC with acceleration feedback	573
8.14.6	APC with load velocity control.....	580
8.14.7	Additional Information	583
8.14.8	Measuring frequency responses.....	585
8.14.9	Function diagrams and parameters	590
8.15	Cogging torque compensation	592
8.15.1	Overview	592
8.15.2	Commissioning.....	592
8.15.3	Filling compensation tables.....	594
8.15.4	Examples	596
8.15.5	Messages and parameters	598
9	Monitoring functions and protective functions	599
9.1	Power unit protection, general	599
9.2	Thermal monitoring and overload responses	600
9.3	Blocking protection.....	602
9.4	Stall protection (vector control only).....	603
9.5	Thermal motor protection	604
9.5.1	Thermal motor models	604
9.5.1.1	Thermal motor model 1	605
9.5.1.2	Thermal motor model 2.....	607
9.5.1.3	Thermal motor model 3.....	608
9.5.1.4	Function diagrams and parameters	609
9.5.2	Motor temperature sensing	611
9.5.3	Sensor Modules	612
9.5.3.1	Sensor Module Cabinet-Mounted	613
9.5.3.2	Sensor Module External.....	613
9.5.3.3	Sensor Module SME 20/25	613
9.5.3.4	Sensor Module External 120/125.....	614
9.5.4	Terminal Modules.....	616
9.5.5	Terminal Module 31	617
9.5.6	Terminal Module 120	618
9.5.7	Terminal Module 150	620
9.5.7.1	Measurement with up to 6 channels	622
9.5.7.2	Measurement with up to 12 channels	622
9.5.7.3	Forming groups of temperature sensors.....	623
9.5.7.4	Evaluating temperature channels	624
9.5.7.5	Setting the smoothing time for temperature channels	625
9.5.8	Motor Module/Power Module chassis format.....	626
9.5.9	Connection of the CU310-2 and the CUA31/CUA32 adapters	627
9.5.10	Motor with DRIVE-CLiQ	628
9.5.11	Temperature sensor evaluation	628
9.5.12	Function diagrams and parameters	629
10	Safety Integrated Basic Functions	633
10.1	Latest information.....	633
10.2	General information	635

10.2.1	Explanations, standards and terminology	635
10.2.2	Supported functions	638
10.2.3	Control possibilities	639
10.2.4	Parameter, Checksum, Version, Password	640
10.2.5	Forced checking procedure (test stop)	642
10.3	Safety instructions.....	644
10.4	Safe Torque Off (STO).....	647
10.5	Safe Stop 1 (SS1, time controlled)	651
10.5.1	SS1 with OFF3.....	651
10.5.2	SS1 with external stop	653
10.5.3	Function diagrams and parameters	653
10.6	Safe Brake Control (SBC).....	654
10.6.1	SBC for Motor Modules in the chassis format	656
10.7	Response times	658
10.7.1	Control of Basic Functions via terminals on the Control Unit and Motor Module (CU310-2 and CU320-2).....	659
10.7.2	Control of Basic Functions via PROFIsafe (CU310-2 and CU320-2)	660
10.7.3	Control of Basic Functions via TM54F	661
10.8	Control via terminals on the Control Unit and Motor/Power Module	662
10.8.1	Simultaneity and tolerance time of the two monitoring channels	666
10.8.2	Bit pattern test.....	667
10.9	Control via TM54F	668
10.9.1	Design	668
10.9.2	Fault acknowledgment	669
10.9.3	F-DI function	669
10.9.4	Function of the F-DO	671
10.10	Commissioning the "STO", "SBC" and "SS1" functions	674
10.10.1	General information about commissioning safety functions	674
10.10.2	Commissioning via direct parameter access	676
10.10.3	Safety faults	679
10.11	Acceptance test and acceptance report	681
10.11.1	Acceptance test structure	682
10.11.1.1	Content of the complete acceptance test	683
10.11.1.2	Content of the partial acceptance test	684
10.11.1.3	Test scope for specific measures	686
10.11.2	Safety logbook	687
10.11.3	Documentation	687
10.11.4	Acceptance tests.....	690
10.11.4.1	General information about acceptance tests	690
10.11.4.2	Acceptance test for Safe Torque Off (STO).....	691
10.11.4.3	Acceptance test for Safe Stop 1, time controlled (SS1)	692
10.11.4.4	Acceptance test for "Safe Brake Control" (SBC)	694
10.11.5	Completion of certificate	695
10.12	Overview of parameters and function diagrams	697
11	Communication.....	699
11.1	Communication according to PROFIdrive	699

11.1.1	PROFIdrive application classes	702
11.1.2	Cyclic communication	704
11.1.2.1	Telegrams and process data	704
11.1.2.2	Information about control words and status words	709
11.1.2.3	Examples	710
11.1.2.4	Motion control with PROFIdrive	713
11.1.3	Parallel operation of communication interfaces	716
11.1.4	Acyclic communication.....	720
11.1.4.1	General information about acyclic communication	720
11.1.4.2	Structure of requests and responses.....	722
11.1.4.3	Determining the drive object numbers	728
11.1.4.4	Example 1: read parameters.....	728
11.1.4.5	Example 2: Writing parameters (multi-parameter request).....	730
11.1.5	Diagnostics channels	734
11.1.5.1	PROFINET-based diagnostics.....	735
11.1.5.2	PROFIBUS-based diagnostics.....	737
11.2	Communication via PROFIBUS DP	742
11.2.1	General information about PROFIBUS	742
11.2.1.1	General information about PROFIBUS for SINAMICS	742
11.2.1.2	Example: telegram structure for cyclic data transmission	745
11.2.2	Commissioning PROFIBUS	748
11.2.2.1	Setting the PROFIBUS interface.....	748
11.2.2.2	PROFIBUS interface in operation	751
11.2.2.3	Commissioning PROFIBUS	752
11.2.2.4	Diagnostics options.....	753
11.2.2.5	SIMATIC HMI addressing	753
11.2.2.6	Monitoring telegram failure	755
11.2.3	Motion Control with PROFIBUS.....	757
11.2.4	Slave-to-slave communication.....	761
11.2.4.1	Setpoint assignment in the subscriber.....	763
11.2.4.2	Activating/parameterizing slave-to-slave communication.....	763
11.2.4.3	Commissioning PROFIBUS slave-to-slave communication	765
11.2.4.4	Diagnosing the PROFIBUS slave-to-slave communication in STARTER	771
11.2.5	Messages via diagnostics channels.....	772
11.3	Communication via PROFINET IO	774
11.3.1	General information about PROFINET IO	774
11.3.1.1	Real-time (RT) and isochronous real-time (IRT) communication	776
11.3.1.2	Addresses	777
11.3.1.3	Data transfer	779
11.3.1.4	Communication channels for PROFINET	780
11.3.2	Drive control with PROFINET	782
11.3.2.1	Media redundancy	785
11.3.3	RT classes for PROFINET IO.....	786
11.3.4	PROFINET GSDML	792
11.3.5	Motion Control with PROFINET	794
11.3.6	Communication with CBE20	797
11.3.7	Communication via PROFINET Gate	798
11.3.7.1	Functions supported by PN Gate.....	799
11.3.7.2	Preconditions for PN Gate	800
11.3.8	PROFINET with 2 controllers.....	802
11.3.8.1	Control Unit settings.....	802

11.3.8.2	Configuring Shared Device	804
11.3.8.3	Overview of important parameters	813
11.3.9	PROFINET system redundancy	814
11.3.9.1	Overview	814
11.3.9.2	Design, configuring and diagnostics	815
11.3.9.3	Messages and parameters	816
11.3.10	PROFenergy	817
11.3.10.1	Tasks of PROFenergy	819
11.3.10.2	PROFenergy commands	820
11.3.10.3	PROFenergy measured values	822
11.3.10.4	PROFenergy energy-saving mode	822
11.3.10.5	PROFenergy inhibit and pause time	823
11.3.10.6	Function diagrams and parameters	823
11.3.11	Messages via diagnostics channels	824
11.3.12	Support of I&M data sets 1...4	826
11.3.13	Dynamic IP address assignment	828
11.4	Communication via MODBUS TCP	830
11.4.1	Overview	830
11.4.2	Configuring Modbus TCP via interface X150	832
11.4.3	Configuring Modbus TCP via interface X1400	833
11.4.4	Mapping tables.....	834
11.4.5	Write and read access using function codes	837
11.4.6	Communication via data set 47	840
11.4.6.1	Communication details.....	841
11.4.6.2	Examples: Read parameter	842
11.4.6.3	Examples: Write parameter	844
11.4.7	Communication procedure.....	846
11.4.8	Messages and parameters	847
11.5	Communication via EtherNet/IP	848
11.5.1	Overview	848
11.5.2	Connect drive device to Ethernet/IP	848
11.5.3	Requirements for communication	850
11.5.4	Configuring communication	850
11.5.5	Supported objects	851
11.5.6	Integrate the drive device into the Ethernet network via DHCP	861
11.5.7	Messages and parameters	862
11.6	Communication via SINAMICS Link	863
11.6.1	Basic principles of SINAMICS Link.....	863
11.6.2	Topology	865
11.6.3	Configuring and commissioning.....	867
11.6.4	Example	871
11.6.5	Communication failure when booting or in cyclic operation.....	874
11.6.6	Examples: Transmission times for SINAMICS Link.....	874
11.6.7	Function diagrams and parameters.....	875
11.7	Communication services and used port numbers	876
11.8	Time synchronization between the control and converter	880
11.8.1	Description	880
11.8.2	Settings	882
11.8.3	Messages and parameters	883

12	Applications	885
12.1	Application examples	885
12.2	Infeed switch on by a drive	888
12.3	Control Units without infeed control	892
12.4	Quick stop in the event of a power failure or emergency stop (servo)	894
12.5	Motor changeover	895
12.6	Application examples with DMC20	901
12.7	DCC and DCB extension applications	905
13	Basic information about the drive system	907
13.1	Parameter	907
13.2	Data sets	910
13.2.1	CDS: Command data set	910
13.2.2	DDS: Drive Data Set	912
13.2.3	EDS: Encoder Data Set	913
13.2.4	MDS: Motor Data Set.....	914
13.2.5	Function diagrams and parameters	916
13.3	Drive objects	917
13.4	BICO technology: Interconnecting signals	920
13.4.1	Binectors, connectors	920
13.4.2	Interconnecting signals using BICO technology	922
13.4.3	Internal coding of the binector/connector output parameters	923
13.4.4	Sample interconnections.....	924
13.4.5	Notes on BICO technology	925
13.4.6	Scaling	926
13.4.7	Propagation of faults	927
13.5	Inputs/outputs.....	928
13.5.1	Digital inputs/outputs.....	929
13.5.2	Use of bidirectional inputs/outputs on the CU.....	934
13.5.3	Analog inputs	935
13.5.4	Analog outputs	937
13.6	Data backup	938
13.6.1	Backing up the non-volatile memory.....	938
13.6.2	Redundant data backup on memory card.....	940
13.7	Parameterizing using the BOP20 (Basic Operator Panel 20).....	942
13.7.1	General information about the BOP20.....	942
13.7.2	Displays and using the BOP20	947
13.7.3	Fault and alarm displays	952
13.7.4	Controlling the drive using the BOP20.....	953
13.8	Examples of replacing components	954
13.9	Notes on DRIVE-CLiQ topology.....	958
13.10	System rules, sampling times and DRIVE-CLiQ wiring	960
13.10.1	Overview of system limits and system utilization.....	960
13.10.2	System rules	961

13.10.3	Rules on the sampling times.....	963
13.10.3.1	Rules when setting the sampling times	963
13.10.3.2	Rules for isochronous mode	966
13.10.3.3	Default settings for the sampling times.....	967
13.10.3.4	Setting the pulse frequency	969
13.10.3.5	Setting sampling times.....	970
13.10.3.6	Overview of important parameters.....	971
13.10.4	Rules for wiring with DRIVE-CLiQ	972
13.10.4.1	Binding DRIVE-CLiQ interconnection rules	972
13.10.4.2	Recommended interconnection rules	974
13.10.4.3	Rules for automatic configuration	977
13.10.4.4	Changing the offline topology in the STARTER commissioning tool.....	978
13.10.4.5	Modular machine concept: Offline correction of the reference topology	979
13.10.5	Notes on the number of controllable drives	982
13.10.5.1	Number of drives depending on the control mode and cycle times.....	982
13.10.5.2	Cycle mix for servo control and vector control.....	988
13.11	Supported sample topologies	991
13.11.1	Topology example: Drives in vector control.....	991
13.11.2	Topology example: Parallel Motor Modules in vector control	993
13.11.3	Topology example: Power Modules.....	994
13.11.4	Example topologies: Drives in servo control.....	996
13.11.4.1	Example: Sampling time 125 μ s	996
13.11.4.2	Examples: Sampling time 62.5 μ s and 31.25 μ s	997
13.11.5	Topology example: Drives in U/f control (vector control).....	998
13.12	DRIVE-CLiQ diagnostics.....	999
13.13	Emergency operating mode for DRIVE-CLiQ components	1000
13.14	Licensing.....	1002
13.14.1	Overview	1002
13.14.2	Creating or displaying license keys via the "WEB License Manager"	1004
13.14.3	Entering the license key in STARTER.....	1005
13.14.4	Entering the license key with BOP20.....	1006
13.14.5	Parameters	1006
13.15	Write and know-how protection	1007
13.15.1	Write protection.....	1007
13.15.2	Know-how protection	1009
13.15.2.1	Copy protection.....	1013
13.15.2.2	Configuring know-how protection	1013
13.15.2.3	Loading know-how protected data to the file system.....	1018
13.15.3	Overview of important parameters.....	1024
A	Appendix.....	1025
A.1	List of abbreviations	1025
A.2	Documentation overview	1035
A.3	Availability of hardware components	1036
A.4	Availability of SW functions.....	1041
A.5	Functions of SINAMICS S120 Combi.....	1054
	Index.....	1057

Fundamental safety instructions

1.1 General safety instructions

 WARNING
Danger to life if the safety instructions and residual risks are not observed If the safety instructions and residual risks in the associated hardware documentation are not observed, accidents involving severe injuries or death can occur. <ul style="list-style-type: none">• Observe the safety instructions given in the hardware documentation.• Consider the residual risks for the risk evaluation.

 WARNING
Danger to life or malfunctions of the machine as a result of incorrect or changed parameterization As a result of incorrect or changed parameterization, machines can malfunction, which in turn can lead to injuries or death. <ul style="list-style-type: none">• Protect the parameterization (parameter assignments) against unauthorized access.• Respond to possible malfunctions by applying suitable measures (e.g. EMERGENCY STOP or EMERGENCY OFF).

1.2 Industrial security

Note

Industrial security

Siemens provides products and solutions with industrial security functions that support the secure operation of plants, solutions, machines, equipment and/or networks. They are important components in a holistic industrial security concept. With this in mind, Siemens' products and solutions undergo continuous development. Siemens recommends strongly that you regularly check for product updates.

For the secure operation of Siemens products and solutions, it is necessary to take suitable preventive action (e.g. cell protection concept) and integrate each component into a holistic, state-of-the-art industrial security concept. Third-party products that may be in use should also be considered. For more information about industrial security, visit this address (<http://www.siemens.com/industrialsecurity>).

To stay informed about product updates as they occur, sign up for a product-specific newsletter. For more information, visit this address (<http://support.automation.siemens.com>).

WARNING

Danger as a result of unsafe operating states resulting from software manipulation

Software manipulation (e.g. by viruses, Trojan horses, malware, worms) can cause unsafe operating states to develop in your installation which can result in death, severe injuries and/or material damage.

- Keep the software up to date.
You will find relevant information and newsletters at this address (<http://support.automation.siemens.com>).
- Incorporate the automation and drive components into a holistic, state-of-the-art industrial security concept for the installation or machine.
You will find further information at this address (<http://www.siemens.com/industrialsecurity>).
- Make sure that you include all installed products into the holistic industrial security concept.

WARNING

Danger to life due to software manipulation when using exchangeable storage media

Storing files onto exchangeable storage media amounts to an increased risk of infection, e.g. with viruses and malware. As a result of incorrect parameterization, machines can malfunction, which in turn can lead to injuries or death.

- Protect files stored on exchangeable storage media from malicious software by taking suitable protection measures, e.g. virus scanners.

Infeed

Infeed units (Line Modules)

Line Modules contain the central line infeed for the DC link. Various Line Modules can be selected to address the various application profiles:

- Basic Line Modules (BLM)
- Smart Line Modules (SLM)
- Active Line Modules (ALM)

The devices are parameterized in Startdrive using the "Infeed" drive object.

Active Line Module

Active Line Modules can supply energy and return regenerative energy to the line supply. A Braking Module and braking resistor are required only if the drives need to be decelerated in a controlled manner after a power failure (i.e. when energy cannot be fed back to the line supply).

Smart Line Module

Smart Line Modules can supply energy and return regenerative energy to the line supply. A Braking Module and braking resistor are required only if the drives need to be decelerated in a controlled manner after a power failure (i.e. when energy cannot be fed back to the line supply). When a Smart Line Module is used as the infeed, the matching line reactor must be installed.

Basic Line Module

Basic Line Modules are designed for infeed operation only, i.e., they are not capable of feeding regenerative energy back into the line supply. If regenerative energy is produced, e.g. when drives brake, it must be converted into heat by means of a Braking Module and a braking resistor.

2.1 Active Infeed

Features

- Controlled DC link voltage whose level can be adjusted (independent of line voltage fluctuations)
- Regenerative feedback capability
- Specific reactive current setting
- Low line harmonics, sinusoidal line current ($\cos \varphi = 1$)
- Several Active Line Modules connected in parallel
- Master/Slave operation for several Active Line Modules
- Parameterizable bandstop filters for Active Line Modules in chassis format

Description

The Active Infeed closed-loop control works in conjunction with the line reactor or an Active Interface Module and the Active Line Module as step-up controller. The level of the DC link voltage can be defined through parameters, and, by means of the control, it is independent of line voltage fluctuations.

The open and closed-loop control firmware of the Active Line Module runs on the Control Unit assigned to it. The Active Line Module and Control Unit communicate via DRIVE-CLiQ.

The operating modes "parallel connection" and "master/slave connection" of the power units are described in this manual in Section "Function modules (Page 433)".

2.1.1 Active Infeed closed-loop control booksize

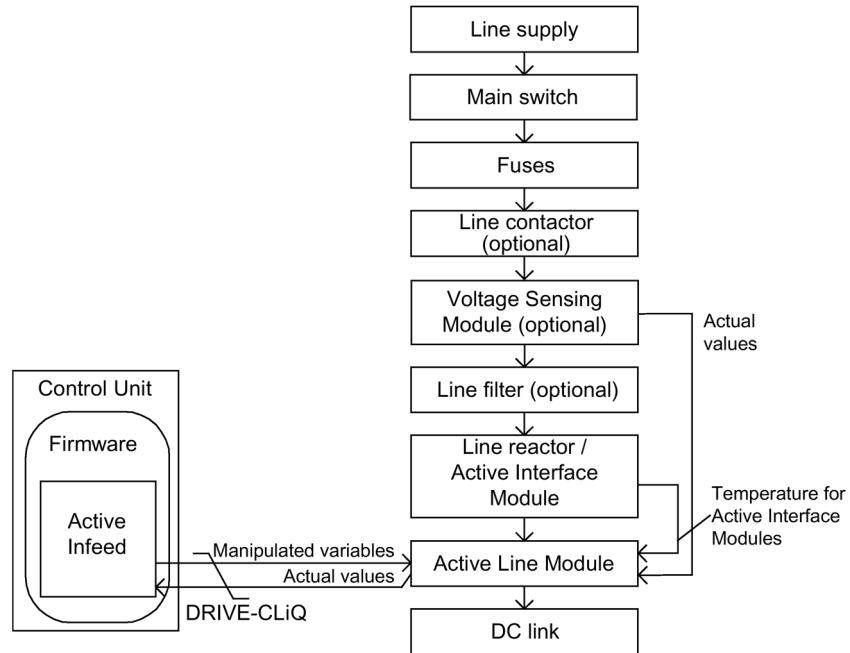

Figure 2-1 Schematic structure of Active Infeed booksize

Active Infeed closed-loop control for Active Line Modules booksize

The Active Line Module can be operated in two different modes depending on the parameterized line supply voltage (p0210):

- Active Mode

In the Active Mode, the DC link voltage is regulated to a variable setpoint (p3510) which results in a sinusoidal line current ($\cos \phi = 1$). The level of the reactive current is also controlled and can be specifically defined.

- Smart Mode

Energy recovery capability is maintained in Smart Mode, although there is a lower DC link voltage in comparison to the Active Mode. The DC link voltage is dependent on the current line voltage.

The Extended Smart Mode can be activated as an option (see Chapter "Extended Smart Mode (Page 42)")

The DC link voltage setpoint (p3510) and the control type are preset as follows during commissioning in line with the connection voltage (p0210):

Table 2- 1 Presetting the control type and DC link voltage booksize

Supply voltage p0210 [V]	380...400	401...415	416...440	460	480
Control type p3400.0	"0" = Active Mode		"1" = Smart Mode		
Vdc_set p3510 [V]	600	625	562-594 ¹⁾	621 ¹⁾	648 ¹⁾

¹⁾ Voltages specified for the Smart Mode are derived from the rectified line supply voltage. The DC link voltage setpoint (p3510) has no effect in this control mode.

The closed-loop controlled mode of booksize power units for p0210 > 415 V can be enabled if the maximum stationary DC link voltage (p0280) is increased as follows: $p0280 \geq 1.5 \times p0210$ and $p0280 > 660$ V.

In this case, the setpoint of the DC link voltage p3510 is not adapted automatically. $p3510 = 1.5 \times p0210$ is recommended. The voltage-controlled operation is activated with $p3400.0 = 0$ and $p3400.3 = 1$.

Voltage Sensing Module 10 (VSM10) used with S120 Active Line Module

Using a "Voltage Sensing Module 10" (VSM10) to sense the line voltage, drives can also be operated in systems with significant frequency fluctuations beyond the range defined in IEC 61000-2-4 if certain supplementary conditions are met. Significant frequency fluctuations may occur, e.g. in (isolated) diesel-electric systems but not in large interconnected systems such as the European interconnected supply network.

In non-European countries, e.g. in countries with power distribution over a wide geographical region

(countries with a large surface such as Australia, USA, China), line voltage dips occur more frequently, the dips are somewhat lower and, above all, they can occur for longer periods of time up to several seconds. In such line systems, the use of the Voltage Sensing Module is urgently recommended.

Commissioning

During commissioning, the device supply voltage (p0210) and the selection of an optional line filter (p0220) must be parameterized.

Following automatic commissioning, the appropriate filter for the matching Active Interface Module is preset as the line filter. If the drive line-up is set up differently, then the line filter type must be adjusted using p0220.

When it is first switched on with a new/modified network, an automatic controller setting must be implemented using the line and DC link identification routine (p3410).

While the identification routine is running, it is not permissible that other loads are switched-in/switched-out.

Note

In a supply system without regenerative feedback capability (e.g. generators), regenerative operation must be inhibited via the binector input p3533.

Note

When a Wideband Line Filter is connected, it must be parameterized with p0220 = 1...5. The temperature sensor must be connected to terminal X21 of the Active Line Module.

The DC link voltage (p3510) can be set within the following limits:

- Upper limit:
 - Maximum DC link voltage (p0280)
 - Product of line voltage (p0210) and max. step-up factor (r3508)
- Lower limit: Supply voltage (p0210) multiplied by 1.42

2.1.2 Active Infeed closed-loop control chassis

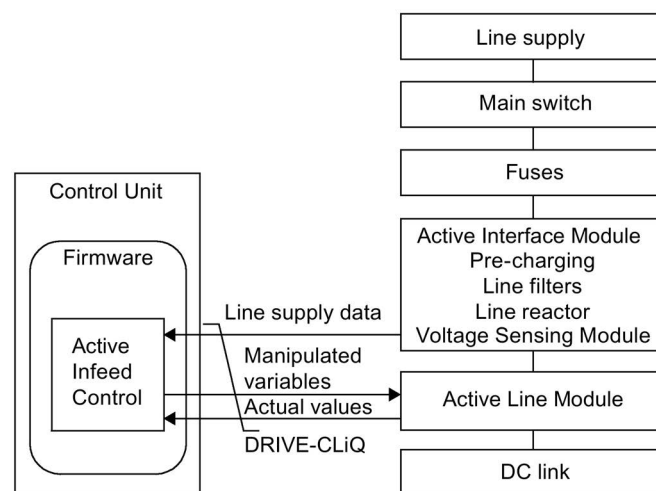

Figure 2-2 Schematic structure of Active Infeed chassis

Operating mode of Active Infeed closed-loop control for Active Line Modules chassis.

Active Line Modules chassis only function in Active Mode.

In the Active Mode, the DC link voltage is regulated to a variable setpoint (p3510) which results in a sinusoidal line current ($\cos \varphi = 1$).

The DC link voltage setpoint (p3510) is preset depending on the supply voltage (p0210) using the equation $p3510 = 1.5 \times p0210$.

Commissioning

The device supply voltage (p0210) must be parameterized during commissioning. The necessary line filter (p0220) is preset.

When it is first switched on with a new/modified network, an automatic controller setting should be implemented using the line / DC link identification routine (p3410).

While the identification routine is running, it is not permissible that other loads are switched-in/switched-out.

Note

In a supply system without regenerative feedback capability (e.g. generators), regenerative operation must be inhibited via the binector input p3533.

The DC link voltage (p3510) can be set within the following limits:

- Upper limit:
 - Maximum DC link voltage (p0280)
 - Product of the supply voltage (p0210) and step-up factor (max. $p3508 = 2.00$)
- Lower limit: Supply voltage (p0210) multiplied by 1.42

For the DC link voltage, the following values apply for chassis units (p0280):

Device voltage	Default setting	Minimum	Maximum
380 ... 480 V	750 V	50 V	785 V
500 ... 690 V	$0.875 \times p0210 + 502 \text{ V}$	50 V	1130 V

NOTICE

Damage to the device caused by components overheating

An excessively high step-up factor for Active Line Modules Chassis can overheat and destroy components.

- Set the step-up factor to a maximum value of 2.00.

2.1.3 Line supply and DC link identification

The characteristic line supply and DC link quantities are determined using the automatic parameter identification routine. They provide the basis to optimally set the controllers in the Line Module.

An optimal setting of the current and voltage control is achieved with the line supply and DC link identification routine. The dynamic response of the current control can be adjusted with p3560.

Note

Repetition of the supply / DC link identification

If the line supply environment or the components connected to the DC link change (e.g. after installation of the equipment at the customer's site or after expanding the drive line-up), the line supply / DC link identification routine should be repeated with p3410 = 5. Only then can it be guaranteed that the infeed operates with the optimum controller settings.

When the identification function is activated, alarm A06400 is output.

Note

While the identification routine is running, it is not permissible that other loads are switched-in/switched-out.

Identification methods

For additional identification methods, see the SINAMICS S120/S150 List Manual.

- p3410 = 4: Identify and save controller setting with L adaptation

An identification run for the total inductance and DC link capacitance is initiated when the pulses are next enabled (2 measuring routines with different current magnitudes). Data determined during identification (r3411 and r3412) is entered into p3421 and p3422 and the controller is recalculated. At the same time, the parameters for current controller adaptation are determined (p3620, p3622). All infeed parameters are then automatically stored in non-volatile memory.

The infeed continues to operate without interruption on the new controller parameters.

- p3410 = 5: Reset, save controller setting with L adaptation

The same measurements and write operations are always carried out for p3410 = 4. Before the first identification run, however, the parameter values for line inductance and DC link capacitance are reset (p3421 = p0223 and p3422 = p0227).

p3410 is automatically set to 0 when one of the two identification routines (p3410 = 4 or p3410 = 5) completes successfully.

Note

Identification using p3410 = 5 should preferably be used.

It may be necessary to reset the closed-loop controller to the factory settings if an identification run was unsuccessful, for example.

2.1.4 Active Infeed open-loop control

The Active Line Module can be controlled via the BICO interconnection using terminals or the fieldbus. The operating status is indicated on the operating display r0002. The missing enable signals for operation (r0002 = 00) are mapped in parameter r0046. The EP terminals (enable pulses) must be connected in accordance with the manual of the corresponding power units. The drive unit must have been commissioned for the first time.

Acknowledging faults

Faults that are still present but the causes of which have been rectified can be acknowledged using a 0/1 edge at the "1st acknowledge faults" signal (p2103).

Switching on the Active Line Module

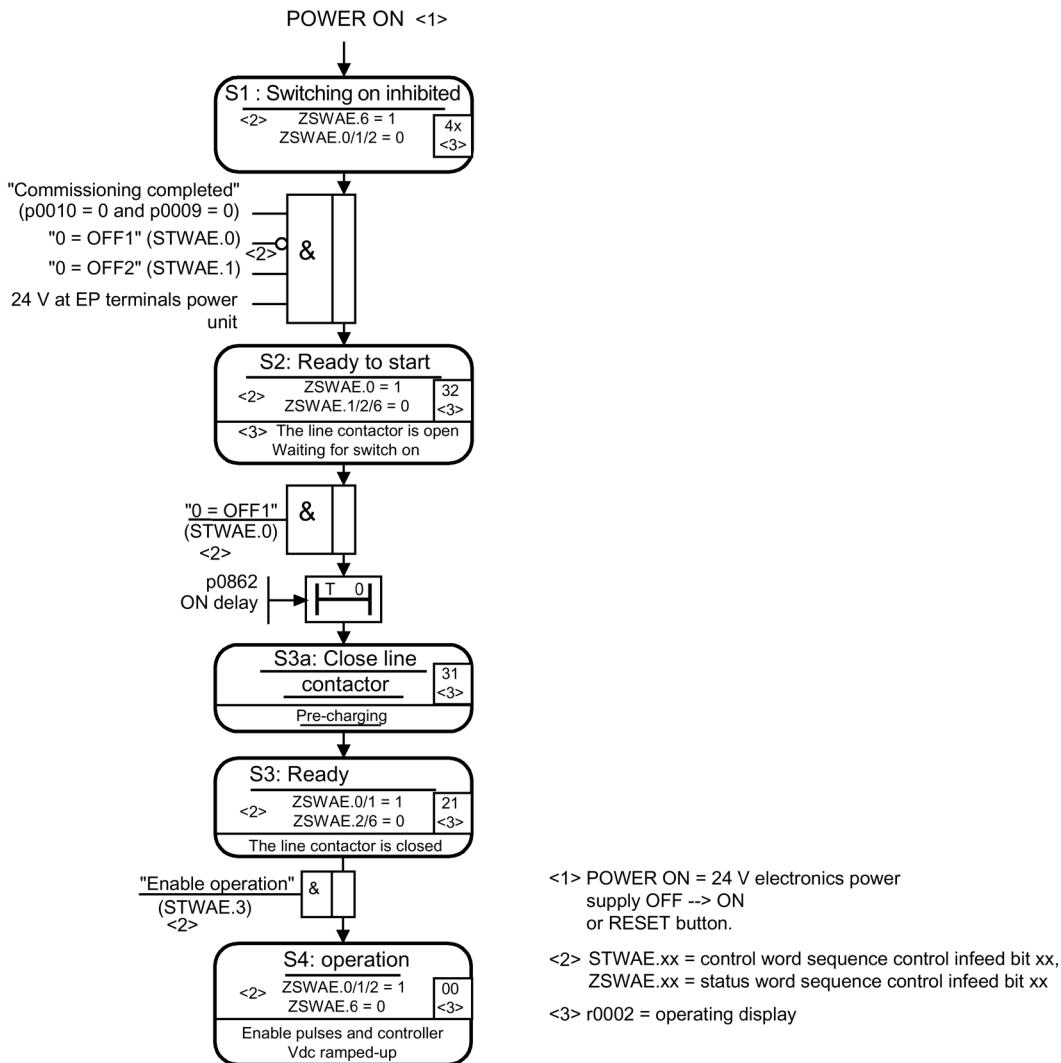

Figure 2-3 Active Infeed power-up

Note

Under the condition that the drive system was commissioned with STARTER and no PROFIdrive telegram was activated, the infeed can be switched on by issuing an enable signal at the EP terminals and a positive signal edge at OFF1 (p0840).

Switching off the Active Line Module

The Active Line Module is switched off by the same procedure used to switch it on, but in the reverse order. However, there is no precharging at switch off.

Switching off the controller with the OFF1 signal is delayed by the time entered in p3490. This allows the attached drives to be braked in a controlled manner. Before the infeed is switched off, the drives connected to the DC link should be in pulse inhibit mode.

Control and status messages

Table 2- 2 Active Infeed open-loop control

Signal name	Internal control word	Binector input	Display of internal control word	PROFIdrive telegram 370
ON/OFF1	STWAE.0	p0840 ON/OFF1	r0898.0	E_STW1.0
OFF2	STWAE.1	p0844 1 OFF2 and p0845 2 OFF2	r0898.1	E_STW1.1
Enable operation	STWAE.3	p0852 Enable operation	r0898.3	E_STW1.3
Disable motor operation	STWAE.5	p3532 Disable motor operation	r0898.5	E_STW1.5
Inhibit regenerating	STWAE.6	p3533 Inhibit regenerating	r0898.6	E_STW1.6
Acknowledge fault	STWAE.7	p2103 1 Acknowledge or p2104 2 Acknowledge or p2105 3 Acknowledge	r2138.7	E_STW1.7
Master control by PLC	STWAE.10	p0854 Master control by PLC	r0898.10	E_STW1.10

Table 2- 3 Active Infeed status message

Signal name	Internal status word	Parameter	PROFIdrive telegram 370
Ready to start	ZSWAE.0	r0899.0	E_ZSW1.0
Ready	ZSWAE.1	r0899.1	E_ZSW1.1
Operation enabled	ZSWAE.2	r0899.2	E_ZSW1.2
Fault active	ZSWAE.3	r2139.3	E_ZSW1.3
No OFF2 active	ZSWAE.4	r0899.4	E_ZSW1.4
Switching-on inhibited	ZSWAE.6	r0899.6	E_ZSW1.6
Alarm active	ZSWAE.7	r2139.7	E_ZSW1.7
Switch-on operation active	ZSWAE.8	r0899.8	E_ZSW1.8
Control requested	ZSWAE.9	r0899.9	E_ZSW1.9
Precharging completed	ZSWAE.11	r0899.11	E_ZSW1.11
Line contactor closed	ZSWAE.12	r0899.12	E_ZSW1.12

2.1.5 Reactive current control

A reactive current setpoint can be set to compensate the reactive current or to stabilize the line voltage in infeed mode. The total setpoint is the sum of the fixed setpoint p3610 and the dynamic setpoint via the connector input p3611.

- The direction of rotation of the line supply is compensated automatically with reactive current control.
 - A negative reactive current setpoint causes an inductive reactive current (overexcited operation).
 - A positive reactive current setpoint generates a capacitive reactive current (underexcited operation).
- The closed-loop control limits the reactive current setpoint dynamically in such a way that the sum of the active current setpoint and the reactive current setpoint does not exceed the maximum device current.
- The reactive current demand of a line filter selected in the configuration wizard is automatically supplied by the Active Infeed Module. This means that the display value of the current reactive current setpoint in r0075 no longer corresponds with the parameterized total reactive current setpoint.
- The reactive power setpoint of the Active Infeed Module with respect to the line supply can be obtained by multiplying the parameterized total reactive current setpoint by 1.73 x rated line voltage.

2.1.6 Harmonics controller

Harmonics in the line voltage cause harmonics in the line currents.

With the activation of the harmonics controller, the ALM generates a pulse pattern that contains harmonic components in addition to the fundamental component. Ideally, the Active Infeed now sets an equally large harmonic voltage to the harmonic voltage on the line side, and does not consume any power for this harmonic. Despite the harmonic component of the line voltage, the line current remains almost sinusoidal and does not load the line supply with additional harmonic currents. However, the specific compensation of voltage harmonics to improve the line supply quality is not possible.

Example: Setting the harmonics controller

The 5th and 7th harmonics are to be compensated.

Table 2- 4 Example parameters for the harmonics controller

Index	p3624	p3625
[0]	5	100 %
[1]	7	100 %

The phase currents in parameter p0069[0...2] (U, V, W) can be checked using the STARTER trace function.

2.1.7 Parameterizable bandstop filters for Active Infeed Controls in chassis format

Parameterizable bandstop filters that can be used to dampen system resonance are available for the current control loop. The main application for these bandstop filters is in weak networks in which the resonance point of the line filter can drop to one quarter of the controller frequency. Resonance effects in oscillating line supplies can be suppressed with the aid of these bandstop filters.

"Additional closed-loop controls" function module

The bandstop filters are managed in the "Additional closed-loop controls" function module.

Activating the function module

1. Mark the infeed in the project navigator and open the "Properties" context menu.
The "Object properties" dialog then opens.
2. Click the "Function modules" tab.
3. Activate the "Additional closed-loop controls" function module in the function modules selection with a mouse click.

Parameter r0108.03 indicates whether the function module has been activated.

Setting the bandstop filters

Because the same filter algorithms are involved, the settings of the bandstop filters are always comparable with the settings of the current setpoint filters (see Section Current setpoint filter (Page 96)).

To prevent resonance effects for nets with low short-circuit power (small RSC), a bandstop filter (with defined notch depth) for approx. 0.25-fold controller frequency (see p0115) is chosen typically. Appropriate values for the attenuation are preset for the numerator and the denominator. Only the natural frequencies for the numerator and the denominator may need to be adapted.

You can configure the bandstop filters for the Active Infeed using the following parameters:

- Negative phase-sequence system control (p3639 ff)
- Fixed setpoints (p2900 ff)
- Output voltage setpoint filter; activation with p5200.0 = 1
- Actual current value filter; activation with p5200.2 = 1
- Vdc actual value filter; activation with p1656.4 = 1

2.1.8 Function diagrams and parameters

Function diagrams (see SINAMICS S120/S150 List Manual)

- 8910 Active Infeed overview
- 8920 Active Infeed - Control word, sequence control, infeed
- ...
- 8940 Active Infeed - controller modulation depth reserve / controller DC link voltage (p3400.0 = 0)
- 8946 Active Infeed - current precontrol / current controller / gating unit (p3400.0 = 0)
- ...
- 8964 Active Infeed - signals and monitoring function, line frequency/Vdc monit. (p3400.0 = 0)

Overview of important parameters (see SINAMICS S120/S150 List Manual)

- r0002 Infeed operating display
- r0046.0...29 CO/BO: Missing enable signals
- r0069[0...8] CO: Phase current actual value
- p0210[0...1] Device supply voltage
- p0220 Infeed line filter type
- p0280 DC link voltage maximum steady-state
- p0840 BI: ON/OFF (OFF1)
- p0844 BI: No coast down / coast down (OFF2)
- p0852 BI: Enable operation / disable operation
- r0898.0...10 CO/BO: Control word sequence control infeed
- r0899.0...12 CO/BO: Status word sequence control infeed
- r2138.7...15 CO/BO: Control word, faults/alarms
- r2139.0...15 CO/BO: Status word, faults/alarms 1
- p3400 Infeed configuration word
- r3405.0...7 CO/BO: Infeed status word
- p3410 Infeed identification method
- r3411[0...1] Infeed inductance identified
- r3412[0...1] Infeed DC link capacitance identified
- p3508 Infeed step-up factor maximum
- p3510 Infeed DC link voltage setpoint
- p3533 BI: Infeed, inhibit regenerative operation

- p3560 Infeed Vdc controller proportional gain
- p3610 Infeed reactive current fixed setpoint
- p3611 CI: Infeed reactive current supplementary setpoint
- p3624[0...1] Infeed harmonics controller order
- p3625[0...1] Infeed harmonics controller scaling
- r3626[0...1] Infeed harmonics controller output

Parameterizable bandstop filters

- p1656[0...n] Signal filter activation
- p1677 Vdc actual value filter 5 type
- p1678 Vdc actual value filter 5 denominator natural frequency
- p1679 Vdc actual value filter 5 denominator natural frequency
- p1680 Vdc actual value filter 5 numerator natural frequency
- p1681 Vdc actual value filter 5 numerator damping
- p2900 CO: Fixed value 1 [%] / fixed value 1 [%]
- p2901 CO: Fixed value 2 [%] / fixed value 2 [%]
- p5200 Signal filter activation
- p5201 Output voltage setpoint filter 5 type
- p5202 Output voltage setpoint filter 5 denominator natural frequency
- p5203 Output voltage setpoint filter 5 denominator damping
- p5204 Output voltage setpoint filter 5 numerator natural frequency
- p5205 Output voltage setpoint filter 5 numerator damping
- p5211 Current actual value filter 7 type
- p5212 Current actual value filter 7 denominator natural frequency
- p5213 Current actual value filter 7 denominator damping
- p5214 Current actual value filter 7 numerator natural frequency
- p5215 Current actual value filter 7 numerator damping

2.2 Smart Infeed

Features

- For Smart Line Modules with a power ≥ 16 kW
- Unregulated DC link voltage
- Regenerative feedback capability

Description

The firmware of the Smart Line Module is located on the assigned Control Unit. The Smart Line Module and Control Unit communicate via DRIVE-CLiQ.

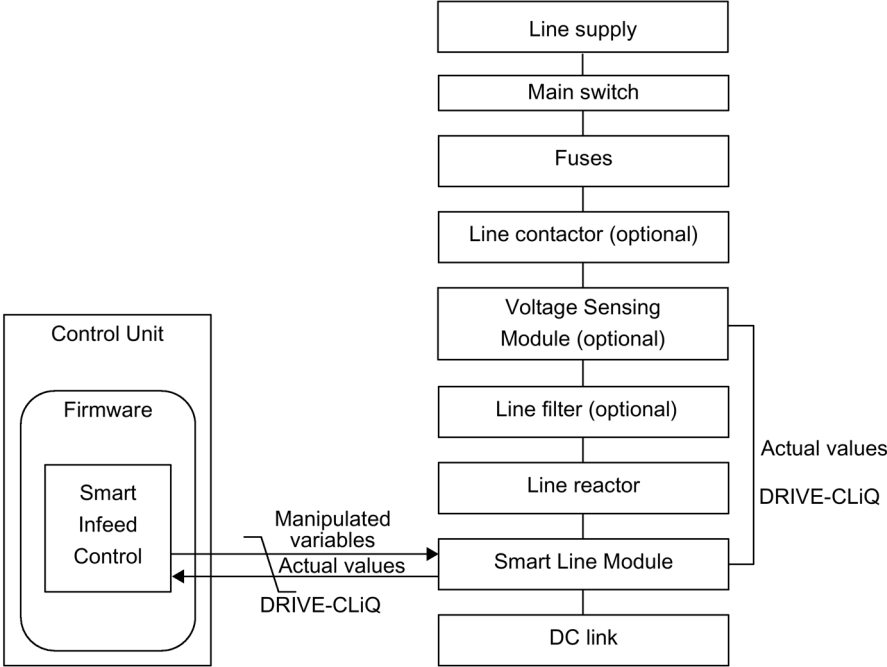

Figure 2-4 Schematic structure of Smart Infeed booksizer

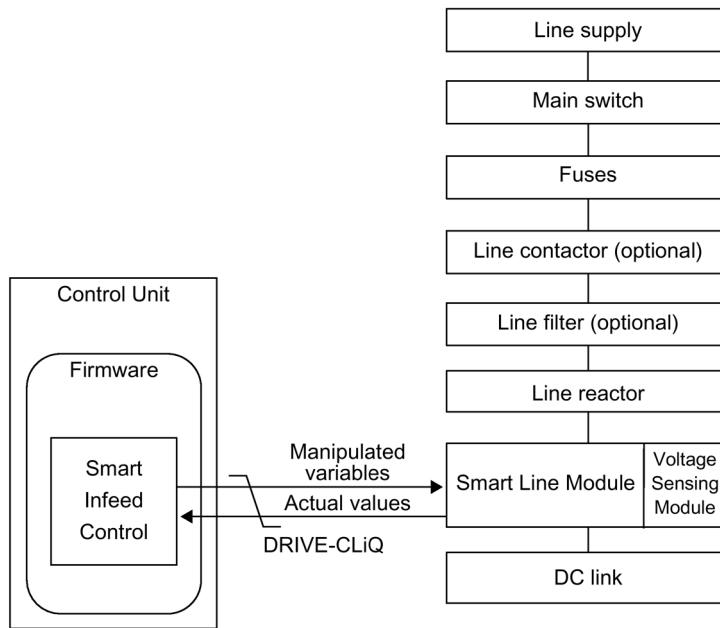

Figure 2-5 Schematic structure of Smart Infeed chassis

Commissioning

The device connection voltage (p0210) must be parameterized during commissioning.

The Extended Smart Mode can be activated as an option (see Chapter "Extended Smart Mode (Page 42)")

Note

In a supply system without regenerative feedback capability (e.g. generators), the regenerative operation of the infeed must be deactivated via the binector input p3533.

Smart Line Modules do not support kinetic buffering in generator mode.

2.2.1 Line supply and DC link identification routine for Smart Infeed Booksize

The characteristic line supply and DC link quantities are determined using the automatic parameter identification routine. They provide the basis to optimally set the controllers in the Line Module.

Note

If the line supply environment or the components connected to the DC link change (e.g. after installation of the equipment at the customer's site or after expanding the drive line-up), the line supply / DC link identification routine should be repeated with p3410 = 5. Only then can it be guaranteed that the infeed operates with an optimum controller setting.

When the identification function is activated, alarm A06400 is output.

Note

While the identification routine is running, it is not permissible that other loads are switched-in/switched-out.

Note

The line supply and DC link identification routine is not permissible for Smart Line Modules of the Chassis type.

Identification methods

Identification method	Description
p3410 = 4	An identification run for the total inductance and DC link capacitance is initiated when the pulses are next enabled (2 measuring routines with different current magnitudes). Data determined during the identification routine (r3411 and r3412) is entered into p3421 and p3422 and the controller is recalculated. At the same time, the parameters for current controller adaptation are determined (p6320, p6322). All infeed parameters are then automatically stored in non-volatile memory. The infeed continues to operate without interruption with the new controller parameters.
p3410 = 5 Preferred	The same measurements and write operations are always carried out for p3410 = 4. However, before the first identification run, the parameter values for line inductance and DC link capacitance are reset (p3421 = p0223 and p3422 = p0227) and the coarse settings are made for the controller.

p3410 is automatically set to 0 when one of the two identification routines (p3410 = 4 or p3410 = 5) is successfully completed.

For additional identification methods, see the SINAMICS S120/S150 List Manual.

It may be necessary to reset the closed-loop controller to the factory settings if an identification run was unsuccessful, for example.

2.2.2 Extended Smart Mode

The operating mode "Extended Smart Mode" represents an extension of the Smart Mode, and facilitates a higher efficiency no-load operation and partial load operation as well as a more rugged operating behavior:

- Significantly reduced reactive power drawn in no-load operation and partial load operation.

At rated load or overload, the operating behavior is equivalent to the normal Smart Mode.

- More stable DC link voltage in no-load operation and partial load operation.

At rated load or overload, the operating behavior is equivalent to the normal Smart Mode.

- Increased degree of ruggedness with respect to brief line disturbances.
- After each POWER ON, automatic adaptation to the actual line parameters.

Note

Restriction

Extended Smart Mode does not work with a Smart Line Module (5 and 10 kW).

Activating the Extended Smart Mode

1. Precondition: The Smart Mode is active (p3400.0 = 1).
2. Activate the Extended Smart Mode with p3440.1 = 1.

All other adjustable parameters (p3441 and following) are appropriately preset for standard applications, or are automatically optimized with the first operating enable (p3440.2 = 0).

2.2.3 Smart Infeed open-loop control

The Smart Line Module can be controlled via the BICO interconnection, e.g. using terminals or the fieldbus. The operating status is indicated on the operating display r0002. The missing enable signals for operation (r0002 = 00) are mapped in parameter r0046. The EP terminals (enable pulses) must be connected in accordance with the manual of the corresponding power units. The drive unit must have been commissioned for the first time.

Acknowledging faults

Faults that are still present but the causes of which have been rectified can be acknowledged using a 0/1 edge at the "1st acknowledge faults" signal (p2103).

Switching on the Smart Line Module

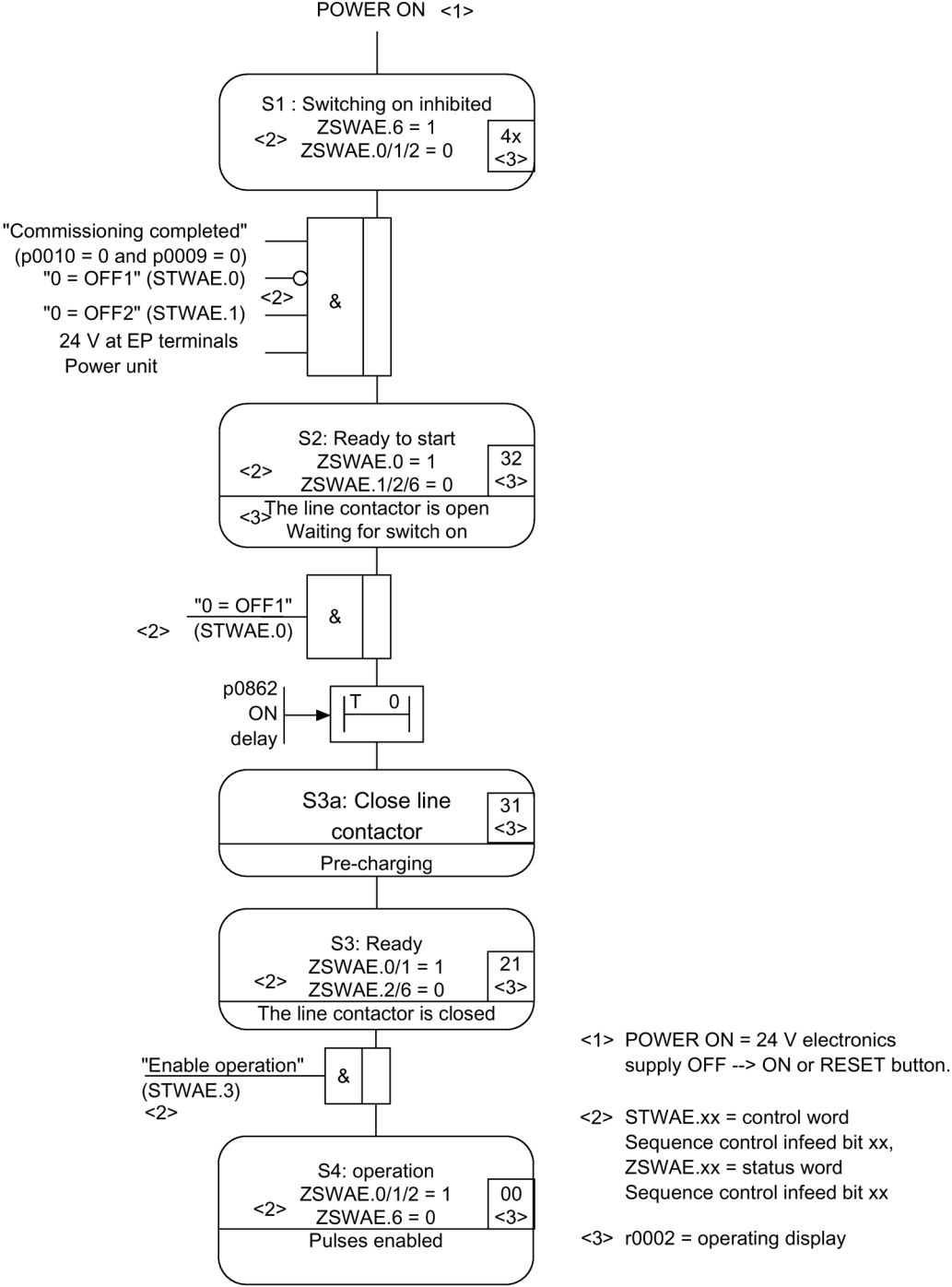

Figure 2-6 Smart Infeed power-up

Note

Under the condition that the drive system was commissioned with STARTER and no PROFIdrive telegram was activated, the infeed can be powered up by issuing an enable signal at the EP terminals and a positive signal edge at OFF1 (p0840).

Switching off the Smart Line Module

The Smart Line Module is switched off by the same procedure used to switch it on, but in the reverse order.

However, there is no precharging at switch off.

Switching off the controller with the OFF1 signal is delayed by the time entered in p3490. This allows the attached drives to be braked in a controlled manner.

Control and status messages

Table 2- 5 Smart Infeed open-loop control

Signal name	Internal control word	Binector input	Display of internal control word	PROFIdrive telegram 370
ON/OFF1	STWAE.0	p0840 BI: ON/OFF1	r0898.0	E_STW1.0
OFF2	STWAE.1	p0844 BI: 1. OFF2 and p0845 BI: 2. OFF2	r0898.1	E_STW1.1
Enable operation	STWAE.3	p0852 BI: Enable operation	r0898.3	E_STW1.3
Inhibit regenerating	STWAE.6	p3533 BI: Infeed, inhibit regenerative operation	r0898.6	E_STW1.6
Acknowledge fault	STWAE.7	p2103 BI: 1. Acknowledge faults or p2104 BI: 2. Acknowledge faults or p2105 BI: 3. Acknowledge faults	r2138.7	E_STW1.7
Master control by PLC	STWAE.10	p0854 BI: Master control by PLC	r0898.10	E_STW1.10

Table 2- 6 Smart Infeed status message

Signal name	Internal status word	Parameter	PROFIdrive telegram 370
Ready to start	ZSWAE.0	r0899.0	E_ZSW1.0
Ready	ZSWAE.1	r0899.1	E_ZSW1.1
Operation enabled	ZSWAE.2	r0899.2	E_ZSW1.2
Fault active	ZSWAE.3	r2139.3	E_ZSW1.3
No OFF2 active	ZSWAE.4	r0899.4	E_ZSW1.4
Switching-on inhibited	ZSWAE.6	r0899.6	E_ZSW1.6
Alarm active	ZSWAE.7	r2139.7	E_ZSW1.7
Control requested	ZSWAE.9	r0899.9	E_ZSW1.9
Precharging completed	ZSWAE.11	r0899.11	E_ZSW1.11
Line contactor closed	ZSWAE.12	r0899.12	E_ZSW1.12

2.2.4 Function diagrams and parameters

Function diagrams (see SINAMICS S120/S150 List Manual)

- 8810 Smart Infeed overview
- 8820 Smart Infeed - Control word, sequence control, infeed
- 8826 Smart Infeed - Status word, sequence control, infeed
- 8828 Smart Infeed - Status word, infeed
- 8832 Smart Infeed - Sequencer
- 8838 Smart Infeed - Missing enables, line contactor control
- 8850 Smart Infeed - Interface to the Smart Infeed (control signals, actual values)
- 8860 Smart Infeed - Signals and monitoring functions, line voltage monitoring
- 8864 Smart Infeed - Signals and monitoring functions, line frequency and Vdc monitoring

Overview of important parameters (see SINAMICS S120/S150 List Manual)

- r0002 Infeed operating display
- r0046.0...29 CO/BO: Missing enable signals
- p0210[0...1] Device supply voltage
- p0840 BI: ON/OFF (OFF1)
- p0844 BI: No coast down / coast down
- p0852 BI: Enable operation / disable operation
- r0898.0...10 CO/BO: Control word sequence control infeed
- r0899.0...12 CO/BO: Status word sequence control infeed
- r2138.7...15 CO/BO: Control word, faults/alarms
- r2139.0...15 CO/BO: Status word, faults/alarms 1
- p3400 Infeed configuration word
- r3405.0...7 CO/BO: Infeed status word
- p3410 Infeed identification method
- p3421 Infeed inductance
- p3422 Infeed DC link capacitance
- p3440 Smart Mode configuration
- p3533 BI: Infeed, inhibit regenerative operation

2.3 Basic Infeed

Features

- For Basic Line Modules chassis and booksize
- Unregulated DC link voltage
- Control of external braking resistors with 20 kW and 40 kW Basic Line Modules (with temperature monitoring)

Description

The Basic Infeed open-loop control can be used to switch on/off the Basic Line Module. The Basic Line Module is an unregulated infeed unit without regenerative feedback capability.

The open-loop control firmware for the Basic Line Module is on the assigned Control Unit. The Basic Line Module and Control Unit communicate via DRIVE-CLiQ.

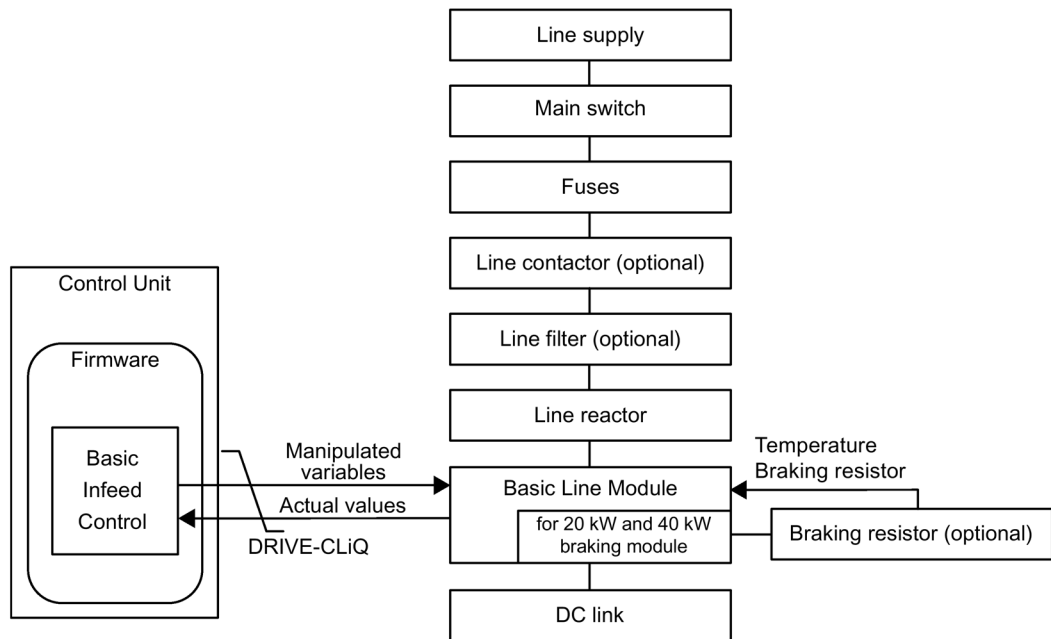

Figure 2-7 Schematic structure of Basic Infeed booksize

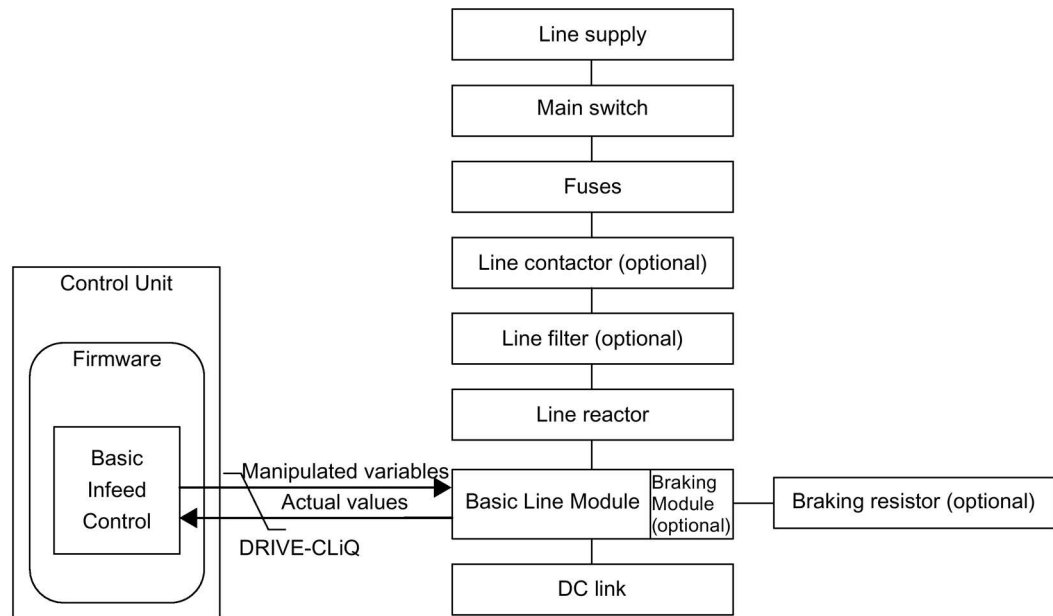

Figure 2-8 Schematic structure of Basic Infeed chassis

Commissioning

The rated line voltage (p0210) must be parameterized during commissioning.

For the 20 kW and 40 kW Basic Line Modules booksize, the temperature switch of the external braking resistor must be connected to X21 on the Basic Line Module.

If a braking resistor has not been connected for 20 kW and 40 kW Basic Line Modules booksize, the Braking Module must be deactivated via p3680 = 1.

An optional Braking Module can be externally mounted on the Basic Line Module chassis. A braking resistor must then be connected to the Braking Module.

If several Motor Modules are supplied from a non-regenerative infeed unit (e.g. a Basic Line Module), or for power failure or overload (for SLM/ALM), the Vdc_max control may only be activated for a Motor Module whose drive should have a high moment of inertia.

For the other Motor Modules this function must be disabled or monitoring must be set.

If the Vdc_max control is active for several Motor Modules, then for an unfavorable parameterization, the controllers can mutually influence one another negatively. The drives can become unstable, individual drives can unintentionally accelerate.

Remedial measures:

- Activating the Vdc_max control:
 - Vector control: p1240 = 1 (factory setting)
 - Servo control: p1240 = 1
 - U/f control: p1280 = 1 (factory setting)
- Inhibiting the Vdc_max control:
 - Vector control: p1240 = 0
 - Servo control: p1240 = 0 (factory setting)
 - U/f control: p1280 = 0
- Activating the Vdc_max monitoring function
 - Vector control: p1240 = 4 or 6
 - Servo control: p1240 = 4 or 6
 - U/f control: p1280 = 4 or 6

**WARNING****Danger to life as a result of unplanned motion of individual drives**

If several Motor Modules are supplied from one infeed unit, then if the Vdc_max control is incorrectly parameterized, individual drives can accelerate in an uncontrolled fashion - which can lead to death or severe injury.

- Only activate the Vdc_max control for the Motor Module whose drive has the highest moment of inertia.
- Inhibit this function for all other Motor Modules, or set this function to monitoring only.

2.3.1 Basic Infeed open-loop control

The Basic Line Module can be controlled via a BICO interconnection, e.g. using terminals or fieldbus. The operating status is indicated on the operating display r0002. The missing enable signals for operation (r0002 = 00) are mapped in parameter r0046. The EP terminals (enable pulses) must be connected in accordance with the manual of the corresponding power units.

Acknowledging faults

Faults that are still present but the causes of which have been rectified can be acknowledged using a 0/1 edge at the "1st acknowledge faults" signal (p2103).

Switching on the Basic Line Module

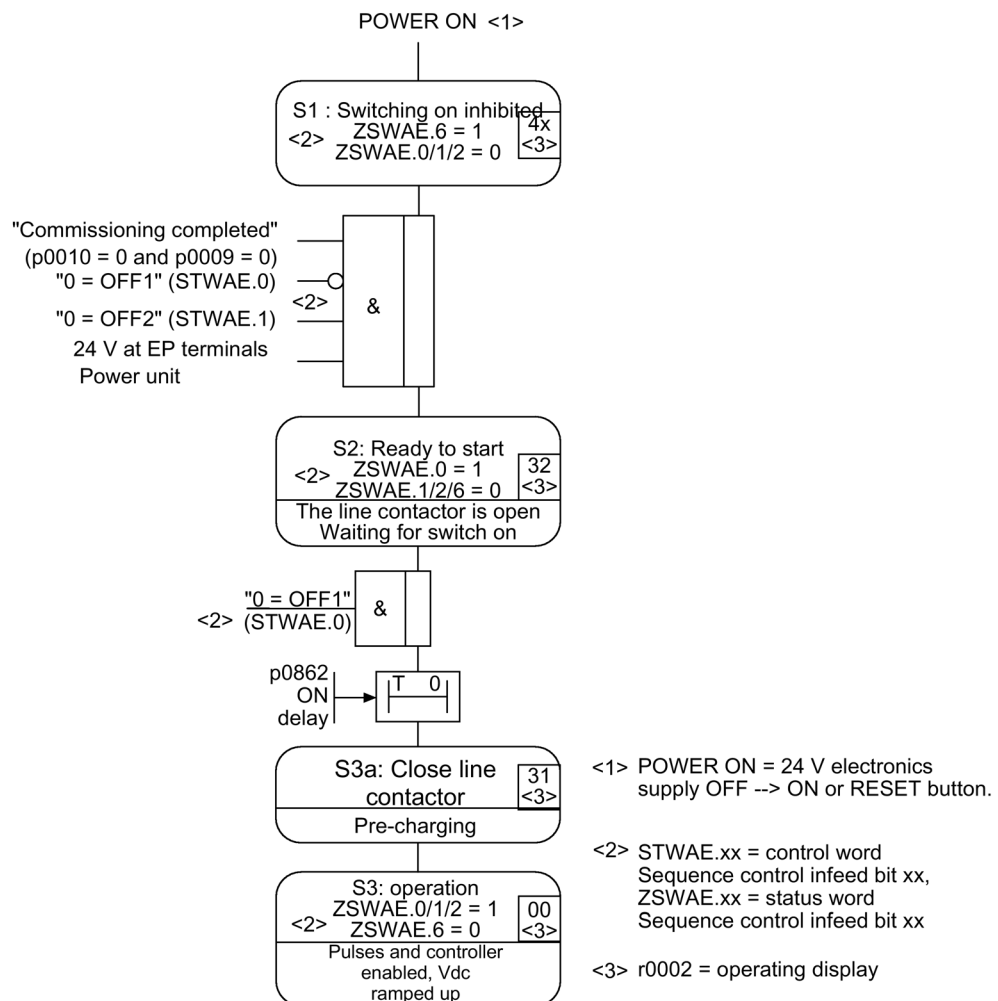

Figure 2-9 Basic Infeed power-up

Note

Under the condition that the drive system was commissioned with STARTER and no PROFIdrive telegram was activated, the infeed can be powered up by issuing an enable signal at the EP terminals and a positive signal edge at OFF1 (p0840).

Switching off the Basic Line Module

For switching off, carry out the steps for switching on in the reverse order. However, there is no pre-charging at switch off.

Control and status messages

Table 2- 7 Basic Infeed open-loop control

Signal name	Internal control word	Binector input	Display of internal control word	PROFIdrive telegram 370
ON/OFF1	STWAE.0	p0840 BI: ON/OFF1	r0898.0	E_STW1.0
OC/OFF2	STWAE.1	p0844 BI: 1st OFF2 and p0845 BI: 2nd OFF2	r0898.1	E_STW1.1
Acknowledge fault	STWAE.7	p2103 BI: 1st acknowledge faults or p2104 BI: 2nd acknowledge faults or p2105 BI: 3rd acknowledge faults	r2138.7	E_STW1.7
Master control by PLC	STWAE.10	p0854 BI: Master control by PLC	r0898.10	E_STW1.10

Table 2- 8 Basic Infeed status message

Signal name	Internal status word	Parameter	PROFIdrive telegram 370
Ready to start	ZSWAE.0	r0899.0	E_ZSW1.0
Ready	ZSWAE.1	r0899.1	E_ZSW1.1
Operation enabled	ZSWAE.2	r0899.2	E_ZSW1.2
Fault active	ZSWAE.3	r2139.3	E_ZSW1.3
No OFF2 active	ZSWAE.4	r0899.4	E_ZSW1.4
Switching on inhibited	ZSWAE.6	r0899.6	E_ZSW1.6
Alarm active	ZSWAE.7	r2139.7	E_ZSW1.7
Control requested	ZSWAE.9	r0899.9	E_ZSW1.9
Pre-charging completed	ZSWAE.11	r0899.11	E_ZSW1.11
Line contactor closed	ZSWAE.12	r0899.12	E_ZSW1.12

2.3.2 Function diagrams and parameters

Function diagrams (see SINAMICS S120/S150 List Manual)

- 8710 Basic Infeed overview
- 8720 Basic Infeed - Control word, sequence control, infeed
- 8726 Basic Infeed - Status word, sequence control, infeed
- 8732 Basic Infeed - Sequencer
- 8738 Basic Infeed - Missing enables, line contactor control
- 8750 Basic Infeed - Interface to the Basic Infeed power unit (control signals, actual values)
- 8760 Basic Infeed - Signals and monitoring functions (p3400.0 = 0)

Overview of important parameters (see SINAMICS S120/S150 List Manual)

- r0002 Infeed operating display
- r0046.0...29 CO/BO: Missing enable signals
- p0210[0...1] Device supply voltage
- p0840 BI: ON/OFF (OFF1)
- p0844 BI: No coast down / coast down (OFF2)
- r0898.0...10 CO/BO: Control word sequence control infeed
- r0899.0...12 CO/BO: Status word sequence control infeed
- p1240[0...n] Vdc controller or Vdc monitoring configuration
- p1280[0...n] Vdc controller or Vdc monitoring configuration (V/f)
- r2138 CO/BO: Control word, faults/alarms
- r2139 CO/BO: Status word, faults/alarms 1
- p3680 BI: Inhibit Braking Module internally

2.4 Line contactor control

This function can be used to control an external line contactor. Opening and closing the line contactor can be monitored by evaluating the feedback contact in the line contactor.

The line contactor can be controlled via r0863.1 with the following drive objects:

- for the INFEED drive object
- for the SERVO and VECTOR drive objects

Note

Further information on the line connection can be found in the manuals:

Example of commissioning line contactor control

Assumption:

- Line contactor control via a digital output of the Control Unit (DI/DO 8)
- Line contactor feedback via a digital input of the Control Unit (DI/DO 9)
- Line contactor switching time less than 100 ms

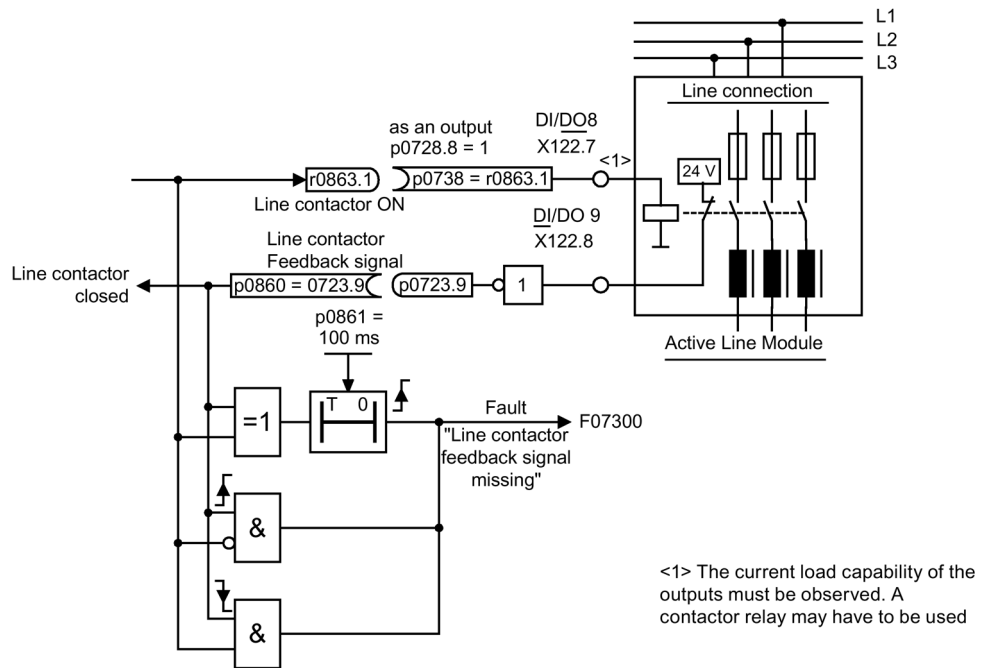

Figure 2-10 Line contactor control

Commissioning steps:

1. Connect the line contactor control contact to DI/DO 8

Note

The current-carrying capacity of the digital output must be observed (see SINAMICS S120 Control Units and Supplementary System Components Manual). A contactor relay may be required!

2. Parameterize DI/DO 8 as output (p0728.8 = 1).
3. Assign parameter p0738 the control signal for the line contactor r0863.1
4. Connect the line contactor feedback contact to DI/DO 9.
5. Assign p0860 an inverted input signal r0723.9.
6. Enter the monitoring time for the line contactor (100 ms) in p0861.

Line contactor behavior for Safe Torque Off (STO)

If the Safety Integrated function initiates an STO, the line contactor opens automatically.

If, however, the line contactor should remain closed when the STO is initiated, make the following setting:

1. Set p0869 = 1.
2. Use p0867 to specify how long the line contactor should remain closed after initiating the STO.

Function diagrams (see SINAMICS S120/S150 List Manual)

- 8938 Active Infeed - Missing enables, line contactor control

Overview of important parameters (see SINAMICS S120/S150 List Manual)

- p0860 BI: Line contactor, feedback signal
- r0863.0...2 CO/BO: Drive coupling status word / control word
- p0867 Power section main contactor hold time after OFF1
- p0869 Configuration sequence control

2.5 Precharging and bypass contactor chassis

Precharging is the procedure for charging the DC link capacitors via resistors. Precharging is normally carried out from the feeding supply network, although it can also be carried out from a precharged DC link. The precharging input circuit limits the charging current of the DC link capacitors.

The precharging input circuit for Active and Smart Infeed in the chassis design comprises a precharging contactor with precharging resistors and a bypass contactor. The Active Line Module controls the precharging input circuit in the Active Interface Module via terminals.

The precharging input circuit in the Active Interface Module of module types FI and GI contains the bypass contactor. The bypass contactor must be provided separately for frame sizes HI and JI.

With the Smart Line Module, precharging is integrated in the Smart Line Module itself, although the bypass contactor must be provided externally.

Further information:

- SINAMICS S120 Manual for Chassis Power Units, Air-cooled
- FAQ with suggested circuit: Connecting an S120 Motor Module to a charged DC link (see Siemens page (<https://support.industry.siemens.com/cs/ww/en/ps/13204/faq>))

Procedure during power ON/OFF

Power ON:

- The precharging contactor is closed and the DC link is charged via the precharging resistors.
- Once precharging is complete, the bypass contactor is closed and the precharging contactor opened. The DC link is precharged and ready for operation. If precharging could not be completed, fault F06000 is output.

Power OFF:

- The pulses are inhibited and the bypass contactor is then opened.

Extended setpoint channel

3.1 Fundamentals

In servo control, the extended setpoint channel is deactivated through the factory setting. If an extended setpoint channel is required, it has to be activated (see Chapter "Activating the function module for servo control (Page 55)").

The extended setpoint channel is always activated in vector control.

Properties of servo control without the "extended setpoint channel" function module

- The setpoint is directly interconnected to p1155[D] (e.g. from a higher-level controller or technology controller)

- Dynamic Servo Control (DSC) only

When using DSC, the "extended setpoint channel" is not used. This unnecessarily uses the computation time of the Control Unit and, for servo control, can be deactivated.

- Deceleration ramp OFF1 via p1121[D]

The deceleration ramp in p1121 is also effective when the "Extended setpoint channel" is deactivated.

- Deceleration ramp OFF3 via p1135[D]
- For PROFIdrive telegrams 2 to 103 and 999 only (free assignment)
- STW 1 bit 5 (freeze ramp-function generator), no function

3.1.1 Activating the function module for servo control

In servo control, the "extended setpoint channel" function module can be activated via the commissioning wizard or the drive configuration (configure DDS).

You can check the current configuration in parameter r0108.8. Once you have set the configuration, you have to download it to the Control Unit where it is stored in a non-volatile memory (see the SINAMICS S120 Commissioning Manual).

Note

When the "extended setpoint channel" function module for servo control is activated, under certain circumstances, the number of drives in the multi-axis group that can be controlled from a Control Unit is reduced.

3.1.2 Description

In the extended setpoint channel, setpoints from the setpoint source are conditioned for motor control.

The setpoint for the motor control can also come from the technology controller (see Chapter "Technology controller (Page 435)").

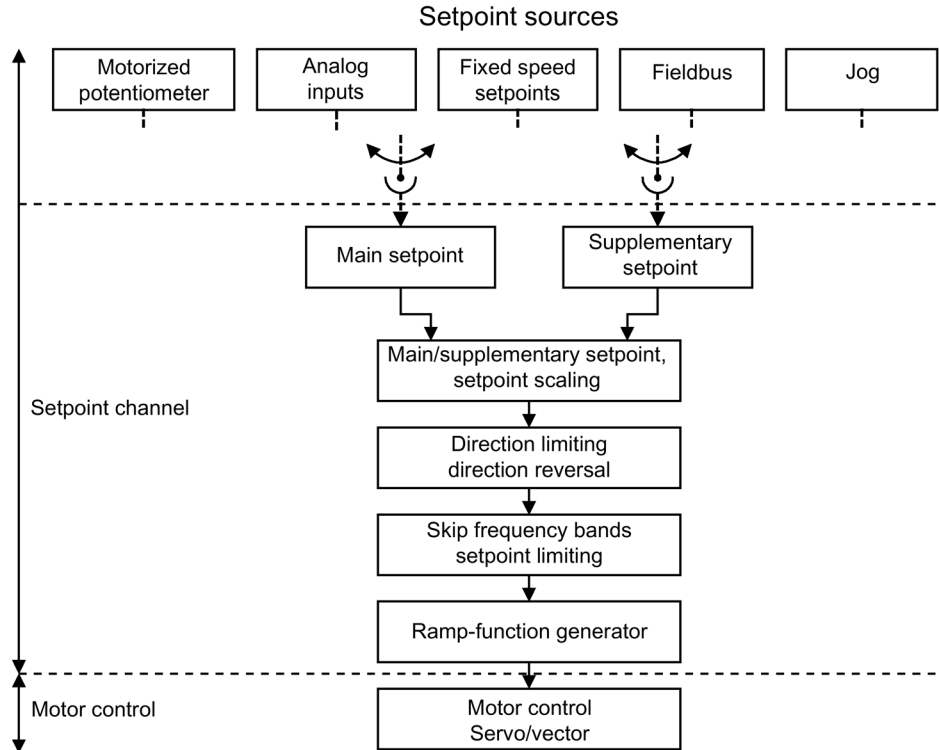

Figure 3-1 Extended setpoint channel

Properties of the extended setpoint channel

- Main/supplementary setpoint, setpoint scaling
- Direction limitation and direction reversal
- Suppression bandwidths and setpoint limitation
- Ramp-function generator

Setpoint sources

The closed-loop control setpoint can be interconnected from various sources using BICO technology, e.g. at p1070 CI: Main setpoint (see function diagram 3030)).

There are various options for setpoint input:

- Fixed speed setpoints
- Motorized potentiometer
- Jog
- Fieldbus
 - Setpoint via PROFIBUS, for example
- Analog inputs of the following exemplary components:
 - e.g. Terminal Board 30 (TB30)
 - e.g. Terminal Module 31 (TM31)
 - e.g. Terminal Module 41 (TM41)

3.2 Motorized potentiometer

This function is used to simulate an electromechanical potentiometer for setpoint input.

You can switch between manual and automatic mode for setpoint input. The specified setpoint is routed to an internal ramp-function generator. Setting values, start values and braking with OFF1 do not require the ramp-function generator of the motorized potentiometer.

The output of the ramp-function generator for the motorized potentiometer is available for further interconnection via a connector output (e.g. interconnection to connector input p1070 - CI: Main setpoint, an additional ramp-function generator is then active).

Properties for manual mode (p1041 = 0)

- Separate binector inputs for Raise and Lower are used to adjust the input setpoint:
 - p1035 BI: Motorized potentiometer, setpoint, raise
 - p1036 BI: Motorized potentiometer, setpoint, lower
- Invert setpoint (p1039)
- Configurable ramp-function generator, e.g.:
 - Ramp-up/ramp-down time (p1047/p1048) referred to p1082
 - Setting value (p1043/p1044)
 - Activate/deactivate initial rounding (p1030.2 = 1/0)
- Non-volatile storage of the setpoints via p1030.3 = 1
- Configurable setpoint for Power ON (p1030.0)
 - Starting value is the value in p1040 (p1030.0 = 0)
 - Starting value is the stored value (p1030.0 = 1)

Properties for automatic mode (p1041 = 1)

- The input setpoint is specified via a connector input (p1042).
- The motorized potentiometer acts like a "normal" ramp-function generator.
- Configurable ramp-function generator, e.g.:
 - Activate/deactivate (p1030.1 = 1/0)
 - Ramp-up/ramp-down time (p1047/p1048)
 - Setting value (p1043/p1044)
 - Activate/deactivate initial rounding (p1030.2 = 1/0)
- Non-volatile storage of the setpoints via p1030.3 = 1
- Configurable setpoint for Power ON (p1030.0)
 - Starting value is the value in p1040 (p1030.0 = 0)
 - Starting value is the stored value (p1030.0 = 1)

Parameterization with STARTER

In the STARTER commissioning tool, the "Motorized potentiometer" parameter screen in the project navigator under the relevant drive is activated by double-clicking "Setpoint channel" > "Motorized potentiometer".

Function diagrams (see SINAMICS S120/S150 List Manual)

- 3001 Setpoint channel overview
- 2501 Internal control/status words - Control word, sequence control
- 3020 Setpoint channel - Motorized potentiometer

Overview of important parameters (see SINAMICS S120/S150 List Manual)

- p1030[0...n] Motorized potentiometer configuration
- p1035[0...n] BI: Motorized potentiometer, setpoint, raise
- p1036[0...n] BI: Motorized potentiometer, setpoint, lower
- p1037[0...n] Motorized potentiometer, maximum speed
- p1038[0...n] Motorized potentiometer, minimum speed
- p1039[0...n] BI: Motorized potentiometer, inversion
- p1040[0...n] Motorized potentiometer start value
- p1041[0...n] BI: Motorized potentiometer, manual/automatic
- p1042[0...n] CI: Motorized potentiometer, automatic setpoint
- p1043[0...n] BI: Motorized potentiometer, accept setting value
- p1044[0...n] CI: Motorized potentiometer, setting value
- r1045 CO: Motorized potentiometer, speed setpoint in front of the ramp-function generator
- p1047[0...n] Motorized potentiometer, ramp-up time
- p1048[0...n] Motorized potentiometer, ramp-down time
- r1050 CO: Motorized potentiometer, setpoint after the ramp-function generator
- p1082[0...n] Maximum speed

3.3 Fixed setpoints

This function can be used to specify preset speed setpoints. These fixed setpoints are defined using parameters and selected via binector inputs. Both the individual fixed setpoints and the effective fixed setpoint are available for further interconnection via a connector output (e.g. to connector input p1070 - Cl: Main setpoint).

Properties

- Number of fixed setpoints: Fixed setpoint 1 to 15
- Selection of fixed setpoints: Binector input bits 0 to 3
 - Binector input bits 0, 1, 2 and 3 = 0 → setpoint = 0 active
 - Unused binector inputs have the same effect as a "0" signal

Parameterization with STARTER

In the STARTER commissioning tool, the "Fixed setpoints" parameterizing screen form in the project navigator under the relevant drive is called by double-clicking "Setpoint channel" > "Fixed setpoints".

Function diagrams (see SINAMICS S120/S150 List Manual)

- 3001 Setpoint channel overview
- 3010 Setpoint channel - Fixed speed setpoints

Overview of important parameters (see SINAMICS S120/S150 List Manual)

- p1001[0...n] CO: Fixed speed setpoint 1
- ...
- p1015[0...n] CO: Fixed speed setpoint 15
- p1020[0...n] BI: Fixed speed setpoint selection Bit 0
- p1021[0...n] BI: Fixed speed setpoint selection Bit 1
- p1022[0...n] BI: Fixed speed setpoint selection Bit 2
- p1023[0...n] BI: Fixed speed setpoint selection Bit 3
- r1024 CO: Fixed speed setpoint effective
- r1197 Current fixed speed setpoint number

3.4 Speed setpoint

3.4.1 Main/supplementary setpoint and setpoint scaling

The supplementary setpoint can be used to incorporate correction values from lower-level controllers. This can be easily carried out using the addition point for the main/supplementary setpoint in the setpoint channel. Both variables are imported via two separate sources and added in the setpoint channel.

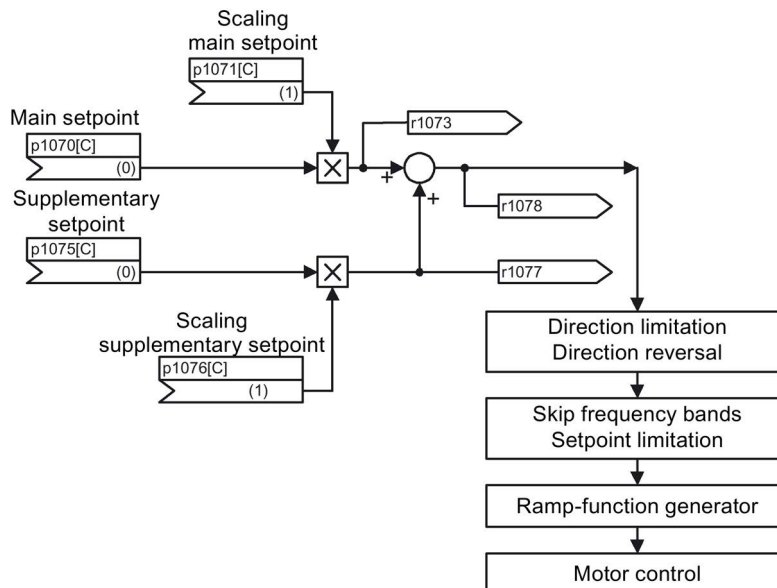



Figure 3-2 Setpoint addition, setpoint scaling

Parameterization with STARTER

The "Speed setpoint" parameterizing screen form is selected with the  icon in the toolbar of the STARTER commissioning tool.

Function diagrams (see SINAMICS S120/S150 List Manual)

- 3001 Setpoint channel overview
- 3030 Setpoint channel - Main setpoint / supplementary setpoint, setpoint scaling, jogging

Overview of important parameters (see SINAMICS S120/S150 List Manual)

- p1070[0...n] CI: Main setpoint
- p1071[0...n] CI: Main setpoint scaling
- r1073 CO: Main setpoint effective
- p1075[0...n] CI: Supplementary setpoint
- p1076[0...n] CI: Supplementary setpoint scaling
- r1077 CO: Supplementary setpoint effective
- r1078 CO: Total setpoint effective

3.4.2 Jogging

The "Jog" function is typically used to slowly move a machine part, e.g. a conveyor belt. The "Jog mode" can also be used to move a drive into the required position independent of the sequence.

The jog mode can be selected via digital inputs or fieldbus (e.g. PROFIBUS). This means that the setpoint is specified via p1058[0...n] and p1059[0...n].

When a jog signal is present, the motor is accelerated to the jog setpoint with the acceleration ramp of the ramp-function generator (referred to the maximum speed p1082; see figure "Flow diagram: Jog 1 and jog 2"). After the jog signal has been deselected, the motor is decelerated via the set ramp of the ramp-function generator.

Note

The "Jog" function is not PROFIdrive-compliant!

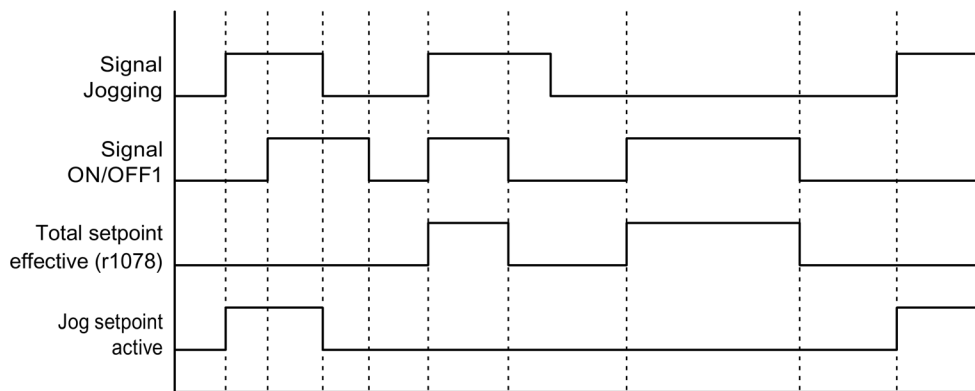

Figure 3-3 Flow diagram: Jog and OFF1

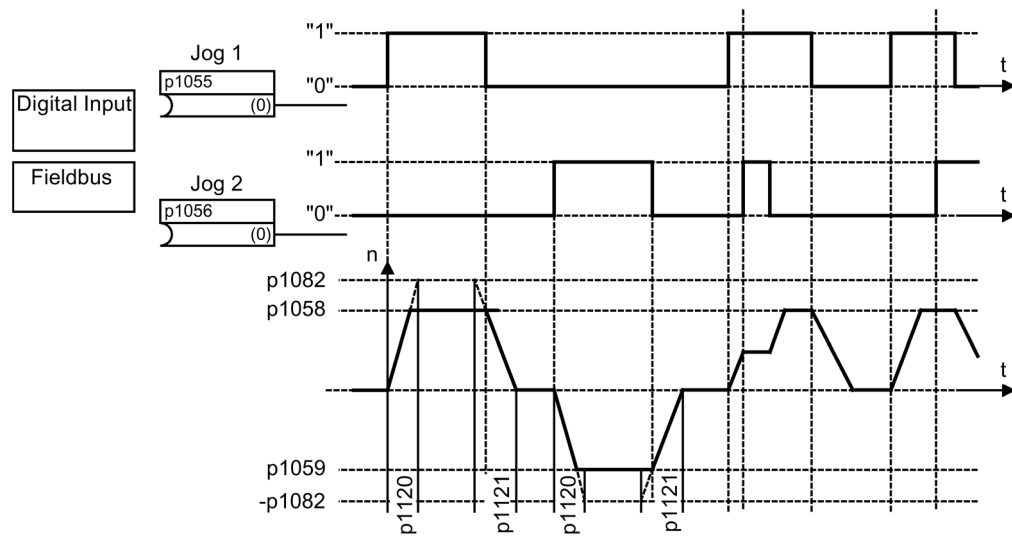

Figure 3-4 Flow diagram: Jog 1 and jog 2

Properties

- If both jog signals are issued at the same time, the current speed is maintained (constant speed phase).
- Jog setpoints are approached and exited via the ramp-function generator.
- Jog is possible from the "Ready to start" state.
- If ON/OFF1 = "1" and jog are selected simultaneously, ON/OFF1 has priority. Therefore ON/OFF1 = "1" must not be active for jog to be activated.
- OFF2 and OFF3 have priority over jog.
- The switch-on command is issued via p1055 and p1056.
- The jog speed is defined via p1058 and p1059.
- The following applies in "Jog mode":
 - The main speed setpoints (r1078) are disabled.
 - The supplementary setpoint 1 (p1155) is disabled.
 - The supplementary setpoint 2 (p1160) is forwarded and added to the current speed.
- The suppression bandwidths (p1091 ... p1094) and the minimum limit (p1080) in the setpoint channel are also active in Jog mode.
- The ramp-function generator cannot be frozen (via p1141) in Jog mode (r0046.31 = 1).

Sequence

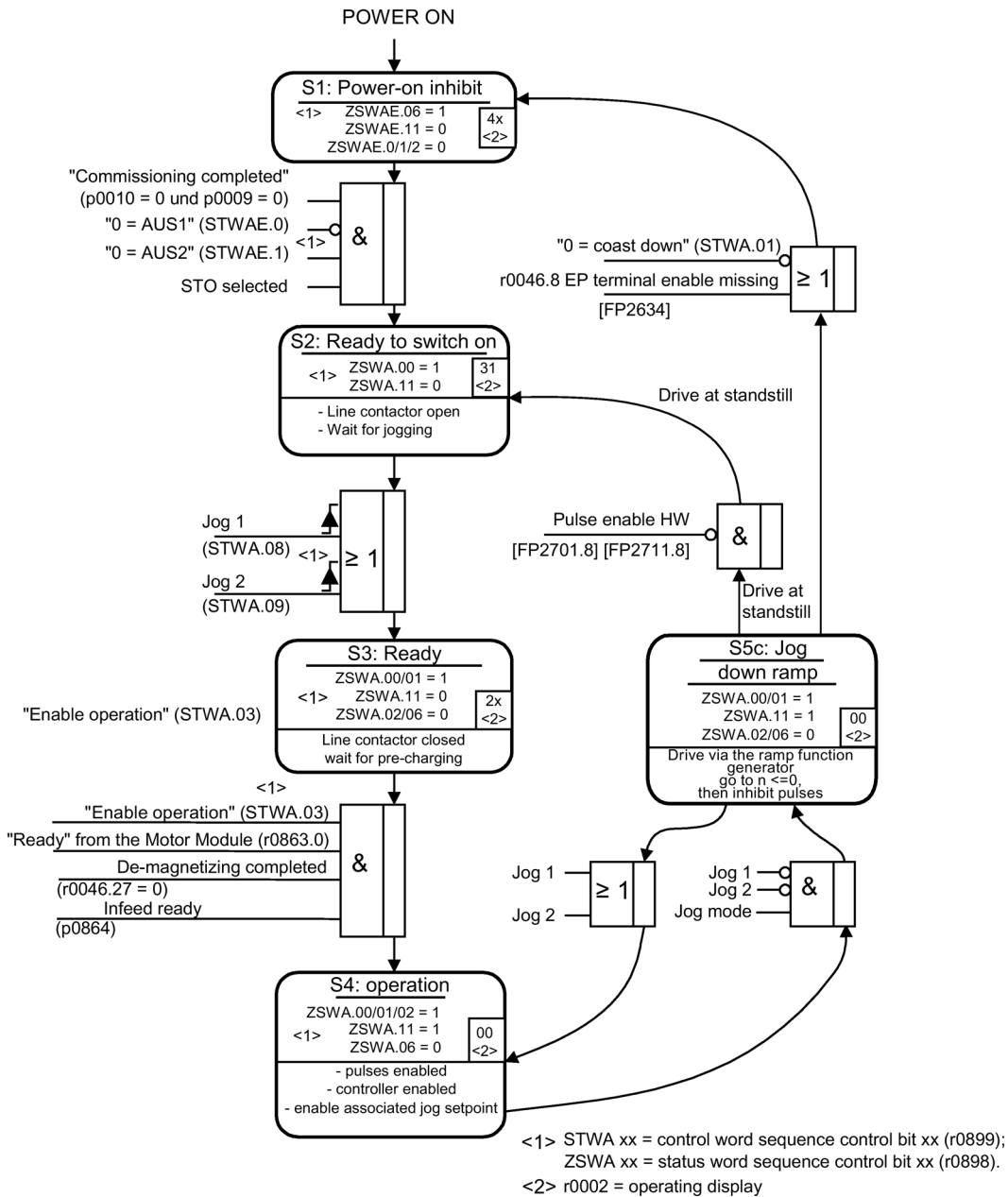

Figure 3-5 Jog sequence

Control and status messages

Table 3- 1 Jog control

Signal name	Internal control word	Binector input	PROFdrive/Siemens telegram 1 ... 352
0 = OFF1	STWA.0	p0840 BI: ON/OFF1	STW1.0
0 = OFF2	STWA.1	p0844 BI: 1. OFF2 p0845 BI: 2. OFF2	STW1.1
0 = OFF3	STWA.2	p0848 BI: 1. OFF3 p0849 BI: 2. OFF3	STW1.2
Enable operation	STWA.3	p0852 BI: Enable operation	STW1.3
Jog 1	STWA.8	p1055 BI: Jog bit 0	STW1.8 ¹⁾
Jog 2	STWA.9	p1056 BI: Jog bit 1	STW1.9 ¹⁾

¹⁾ Interconnected automatically in telegrams 7, 9, 110, and 111 only.

Table 3- 2 Jog status message

Signal name	Internal status word	Parameter	PROFdrive/Siemens telegram 1 ... 352
Ready to start	ZSWA.0	r0899.0	ZSW1.0
Ready	ZSWA.1	r0899.1	ZSW1.1
Operation enabled	ZSWA.2	r0899.2	ZSW1.2
Switching-on inhibited	ZSWA.6	r0899.6	ZSW1.6
Pulses enabled	ZSWA.11	r0899.11	ZSW2.10 ²⁾

²⁾ Only available in Interface Mode p2038 = 0.

Parameterization with STARTER

The "Speed setpoint jog" parameterizing screen form is selected via the  icon in the toolbar of the STARTER commissioning tool:

Function diagrams (see SINAMICS S120/S150 List Manual)

- 3001 Setpoint channel overview
- 2610 Sequence control - Sequencer
- 3030 Setpoint channel - Main/supplementary setpoint, setpoint scaling, jogging

Overview of important parameters (see SINAMICS S120/S150 List Manual)

- p1055[0...n] BI: Jog bit 0
- p1056[0...n] BI: Jog bit 1
- p1058[0...n] Jog 1 speed setpoint
- p1059[0...n] Jog 2 speed setpoint
- p1082[0...n] Maximum speed
- p1120[0...n] Ramp-function generator ramp-up time
- p1121[0...n] Ramp-function generator ramp-down time

3.4.3 Direction of rotation limiting and direction reversal

A reversing operation involves a direction of rotation reversal. Selecting setpoint inversion p1113[C] can reverse the direction of rotation in the setpoint channel.

Parameter p1110[C] or p1111[C] can be set respectively to prevent input of a negative or positive setpoint via the setpoint channel. However, the following settings for minimum speed (p1080) in the setpoint channel are still operative. With the minimum speed, the motor can turn in a negative direction, although p1110 = 1 is set.

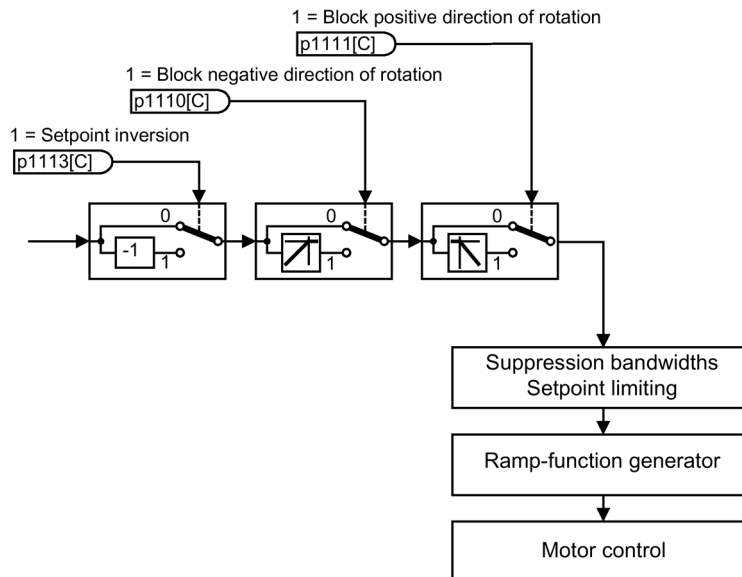



Figure 3-6 Direction of rotation limiting and direction of rotation reversal

Parameterization with STARTER

The "Speed setpoint" parameterizing screen form is selected with the  icon in the toolbar of the STARTER commissioning tool.

Function diagrams (see SINAMICS S120/S150 List Manual)

- 3001 Setpoint channel overview
- 3040 Setpoint channel - Direction limitation and direction reversal

Overview of important parameters (see SINAMICS S120/S150 List Manual)

- p1110[0...n] BI: Block negative direction
- p1111[0...n] BI: Block positive direction
- p1113[0...n] BI: Setpoint inversion

3.5 Speed limiting

In the range from 0 rpm to the speed setpoint, a drive train (e.g. motor, clutch, shaft, machine) can have one or more points of resonance. These resonances lead to oscillations. The suppression bandwidths can be used to prevent operation in the resonance frequency range.

The limit frequencies can be set via p1080[D] and p1082[D]. Further, using connectors p1085[C] and p1088[C] it is possible to influence these limits in operation.

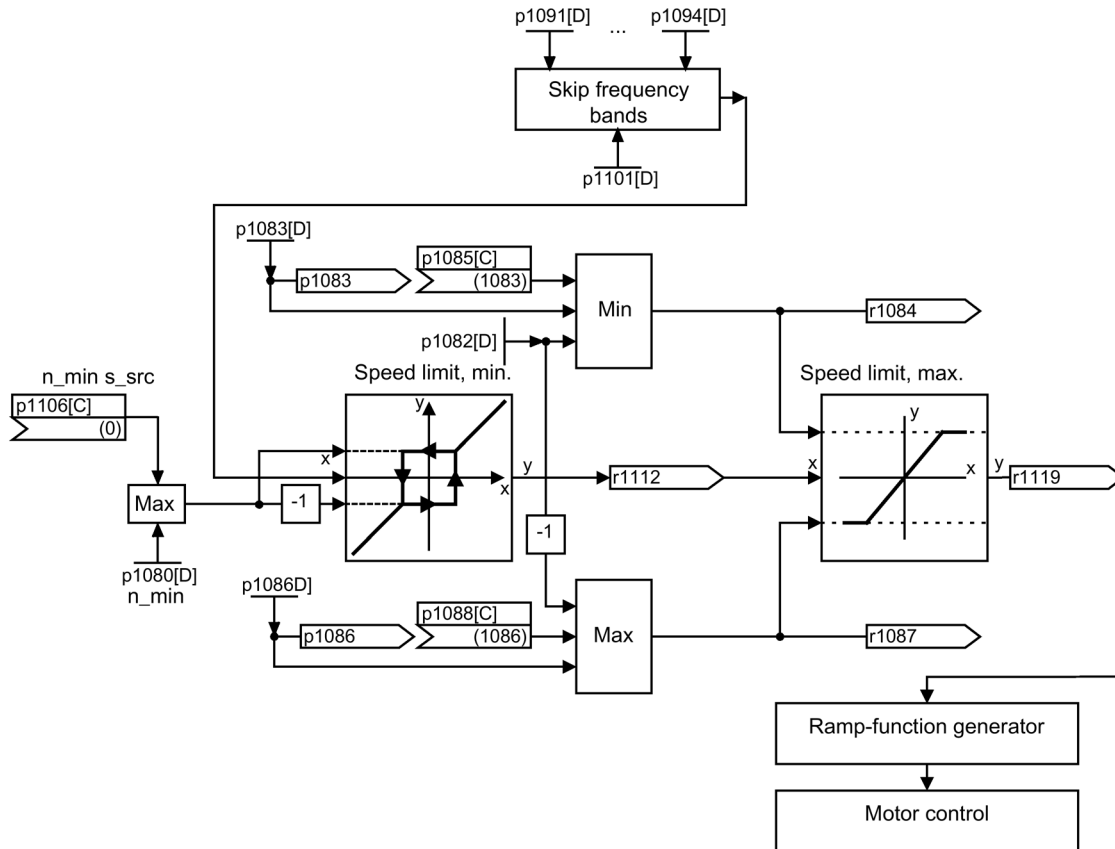



Figure 3-7 Skip frequency bands, setpoint limitation, minimum speed

Minimum speed

Using parameter p1106[0...n], a minimum speed n_min s_src or minimum velocity can be set, which is wired via BICO.

Parameterization with STARTER

The "Speed limitation" parameterizing screen is selected with the  icon in the toolbar of the STARTER commissioning tool.

Function diagrams (see SINAMICS S120/S150 List Manual)

- 3001 Setpoint channel overview
- 3050 Setpoint channel - Skip frequency bands and speed limiting

Overview of important parameters (see SINAMICS S120/S150 List Manual)**Setpoint limitation**

- p1080[0...n] Minimum speed
- p1082[0...n] Maximum speed
- p1083[0...n] CO: Speed limit in positive direction of rotation
- r1084 CO: Speed limit positive effective
- p1085[0...n] CI: Speed limit in positive direction of rotation
- p1086[0...n] CO: Speed limit in negative direction of rotation
- r1087 CO: Speed limit negative effective
- p1088[0...n] CI: Speed limit in negative direction of rotation
- p1106[0...n] CI: Minimum speed signal source
- r1119 CO: Ramp-function generator setpoint at the input

Skip frequency bands

- p1091[0...n] Skip speed 1
- ...
- p1094[0...n] Skip speed 4
- p1101[0...n] Skip speed bandwidth

3.6 Ramp-function generator

Function of the ramp-function generator

The ramp-function generator is used to limit the acceleration in the event of abrupt setpoint changes and so helps to prevent load surges throughout the complete drive train. The ramp-up time $p1120[0\dots n]$ and ramp-down time $p1121[0\dots n]$ can be used to set mutually independent acceleration and deceleration ramps. This allows a controlled transition to be made in the event of setpoint changes.

The maximum speed $p1082[0\dots n]$ is used as a reference value for calculating the ramps from the ramp-up and ramp-down time. For a quick stop (OFF3), a special adjustable ramp is available via the ramp-down time $p1135[0\dots n]$ (e.g. for quick, controlled stopping after an EMERGENCY OFF button has been pressed).

There are two types of ramp-function generator:

- Basic ramp-function generator with
 - Ramp up and ramp down
 - Ramp down for quick stop (OFF3)
 - Tracking configurable via parameter $p1145$
 - Setting values for the ramp-function generator
- The extended ramp-function generator also has
 - Initial and final rounding

Note

The ramp-function generator cannot be frozen (via $p1141$) in jog mode ($r0046.31 = 1$).

Properties of the basic ramp-function generator

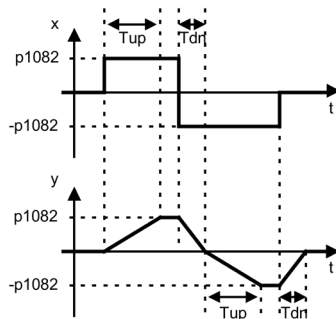

Figure 3-8 Ramp-up and ramp-down with the basic ramp-function generator

- Ramp-up time T_{up} $p1120[0\dots n]$
- Ramp-down time T_{dn} $p1121[0\dots n]$

- OFF3 ramp-down:
 - OFF3 ramp-down time p1135[0...n]
- Set ramp-function generator:
 - Setting value ramp-function generator p1144[0...n]
 - Signal, set ramp-function generator p1143[0...n]
- Freezing of the ramp-function generator using p1141 (not in jog mode r0046.31 = 1)

Properties of the extended ramp-function generator

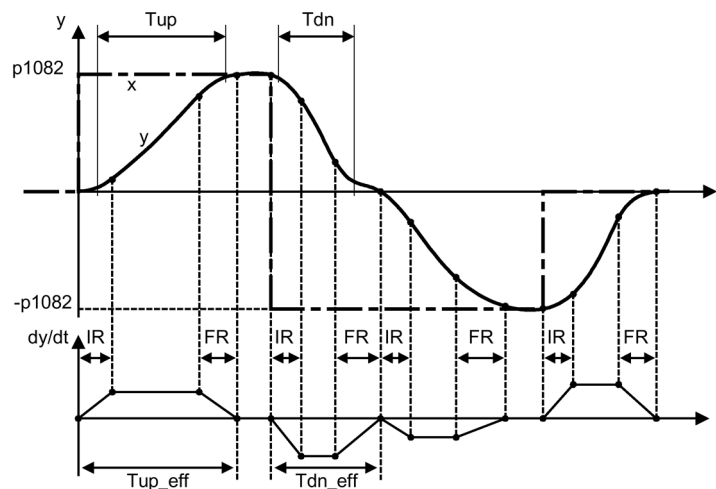

Figure 3-9 Extended ramp-function generator

- Ramp-up time T_{up} p1120[0...n]
- Ramp-down time T_{dn} p1121[0...n]
- Initial rounding IR p1130[0...n]
- Final rounding FR p1131[0...n]
- Effective ramp-up time
 $T_{up_eff} = T_{up} + (IR/2 + FR/2)$
- Effective ramp-down time
 $T_{dn_eff} = T_{dn} + (IR/2 + FR/2)$
 - OFF3 ramp-down
 - OFF3 ramp-down time p1135[0...n]
 - OFF3 initial rounding p1136[0...n]
 - OFF3 final rounding p1137[0...n]
- Set ramp-function generator
 - Setting value ramp-function generator p1144[0...n]
 - Signal, set ramp-function generator p1143[0...n]

- Select ramp-function generator rounding type p1134[0...n]
 - p1134 = "0": continuous smoothing; rounding is always active. Overshoots can occur. If the setpoint changes, final rounding is carried out and then the direction of the new setpoint is adopted.
 - p1134 = "1": discontinuous smoothing; for a setpoint change, the change is immediately made to the direction of the new setpoint.
- Ramp-function generator configuration, deactivate rounding at zero point p1151[0...n]
- Freezing of the ramp-function generator using p1141 (not in jog mode r0046.31 = 1)

Scaling of the up ramp and the down ramp

In order to be able to influence the ramp times set in parameters p1120 and p1121 cyclically via PROFIdrive telegrams, scaling is available for the ramp times.

- Using p1138[0...n], the signal source for scaling the ramp-up time p1120[0...n] of the ramp-function generator is set.
- Using p1139[0...n], the signal source for scaling the ramp-down time p1121[0...n] of the ramp-function generator is set.

The ramp times can be changed independently of one another in a cyclic PROFIdrive telegram. If the ramp-up time and the ramp-down time are to be changed together, then the scaling factor transferred in the PROFIdrive telegram is connected to both connectors.

The scaling also affects the initial and final rounding. However, it does not have the same effect as in the acceleration ramp. This is the reason why an incorrect effective ramp-up time is displayed. With scaling of approx. 50% to 200%, you get the most accurate effective ramp-up times.

Override of the ramp-function generator

- Down ramp for Safety Integrated functions:
If Safety Integrated functions are activated and the down ramp is monitored, only the OFF3 ramp according to p1135 is effective. The speed setpoint limit is selected using p1051/p1052.
- Down ramp for the "Extended stop and retract" function module (ESR):
If ESR is activated, p0893 is used to enter the setpoint for the end speed of the ramp-function generator. Instead of the ramp time of the ramp-function generator, ramp-down is controlled using the OFF3 ramp.

Parameterization with STARTER

The "Ramp-function Generator" parameter screen is selected with the  icon in the toolbar of the STARTER commissioning tool.

3.6.1 Ramp-function generator tracking

A ramp-function generator (RFG) can be operated with or without tracking.

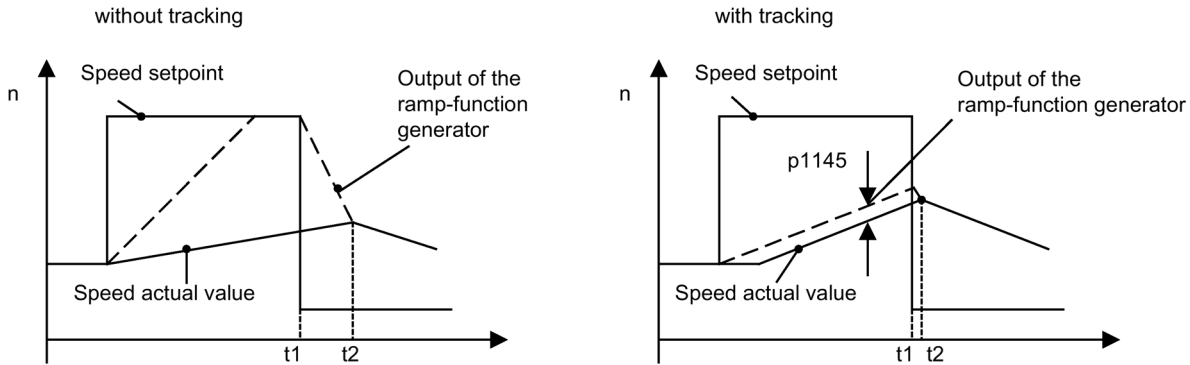

Figure 3-10 Ramp-function generator tracking

Without ramp-function generator tracking

- $p1145 = 0$
- Drive accelerates until $t2$ although setpoint $<$ actual value

With standard ramp-function generator tracking

- At $p1145 > 1$ (values between 0 and 1 are not applicable), ramp-function generator tracking is activated when the torque limit is approached. The ramp-function generator output thereby only exceeds the actual speed value by a deviation value that can be defined in $p1145$.
- $t1$ and $t2$ almost identical

Note

Smaller motors

For smaller motors and depending on the controller settings required for the application there may still be a greater deviation between the setpoint and the actual value. In this case any sudden cancellation of the torque could result in a greater uncontrolled speed jump. By setting the parameter $p1400.16 = 1$ the setpoint value becomes even more closely connected with the actual value and the speed jump is reduced. With this parameter setting the integral component of the speed controller is only stopped if it reaches the torque limit.

Standard ramp-function generator tracking

If the load torque exceeds the torque limit of the drive and so causes the actual speed to diminish, the ramp-function generator output is not tracked to the actual speed value. If the torque limit is overshoot during the ramp-up because the ramp-up time was selected too small, the effective ramp-up time of the ramp-function generator lengthens.

Result: Once the load torque decreases, the drive accelerates again at the current limit to the setpoint. The ramp-up is stopped when the torque, power or current limit is reached. p1145 can be used to set the permitted following error. The speed setpoint is so tracked to the set permitted following error. The acceleration ramp is flattened. If the torque decreases, the ramp-up continues on the speed setpoint with a flattened ramp to the torque/current limit.

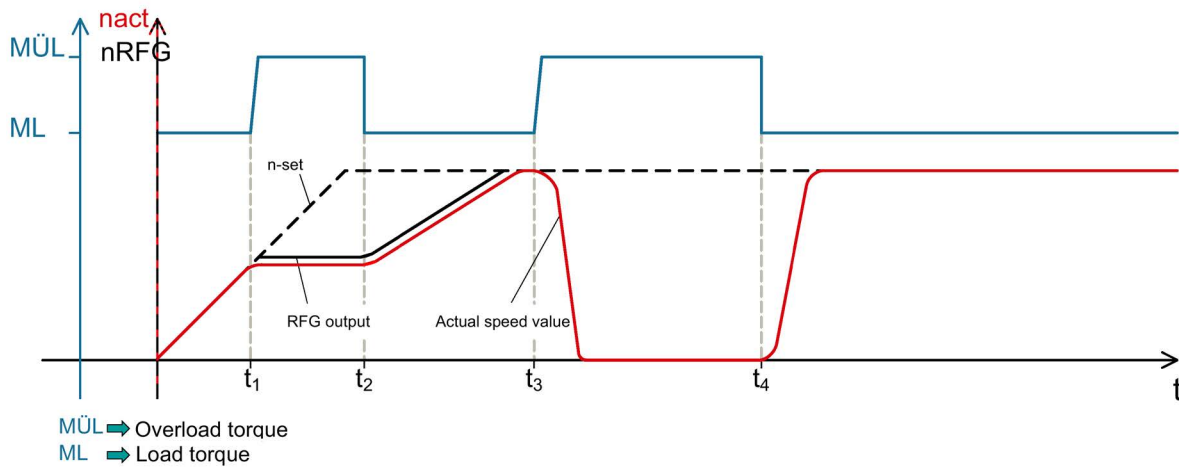

Figure 3-11 Standard ramp-function generator tracking

At the times t_1 and t_3 , an overload torque M_{OVL} starts to act on the drive in addition to the load torque M_L . The torque limit of the drive is exceeded.

For t_1 the drive is being ramped up along specified ramp-function generator ramp. The additional torque prevents the further acceleration of the motor to the rated speed on the ramp-function generator ramp.

The ramp-function generator output is tracked to the actual speed value when $p1145 > 1$ which causes a flattening of the rise ramp for the decrease of M_{OVL} . The drive accelerates with flattened ramp at the current/torque limit to the speed setpoint (t_2).

For t_3 , the drive runs with the specified speed setpoint and is already in field weakening. The additional torque causes the drive to be braked to standstill.

For t_4 , the torque reduces again to M_L . Because the ramp-function generator output is not tracked to the actual speed value, the drive now accelerates at the torque/current limit to the speed setpoint.

Extended ramp-function generator tracking

The extended ramp-function generator tracking returns the ramp-function generator output to the actual speed value when the drive reaches the torque limit. Consequently, the drive does not return to the current limit but rather back on the set acceleration ramp to the original setpoint.

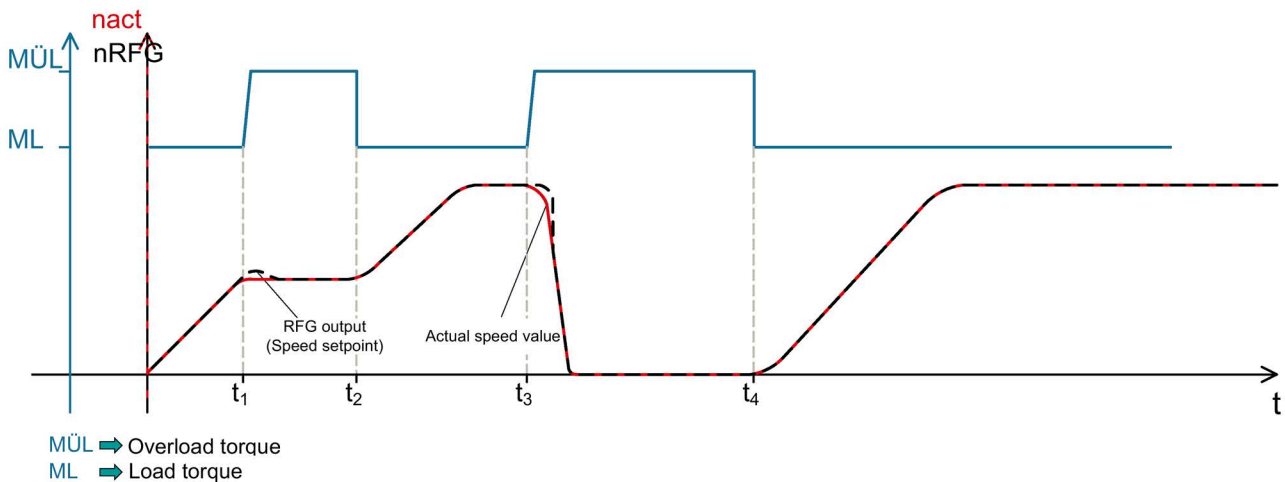

Figure 3-12 Extended ramp-function generator tracking

The additional torque starts to act at the times t_1 and t_3 and the ramp-function generator output is tracked to the actual speed value. This causes the drive to be accelerated to the speed setpoint on the specified ramp-function generator ramp when the torque falls again to M_L (t_2 and t_4).

2 versions can be used for the extended ramp-function generator tracking:

- The ramp-function generator tracking is always active ($p1151.1 = 1$). For load surges, the output of the ramp-function generator is tracked to the actual value. The tracking ends for setpoint zero.
- The ramp-function generator tracking is always active ($p1151.2 = 1$). For load surges, the output of the ramp-function generator is tracked to the actual value. The tracking continues for a polarity change.

3.6.2 Signal overview, function diagrams and important parameters

Signal overview (see SINAMICS S120/S150 List Manual)

- Control signal STW1.2 OFF3
- Control signal STW1.4 Enable ramp-function generator
- Control signal STW1.5 Start/stop ramp-function generator
- Control signal STW1.6 Enable setpoint
- Control signal STW2.1 Bypass ramp-function generator

Function diagrams (see SINAMICS S120/S150 List Manual)

- 3001 Setpoint channel overview
- 3060 Setpoint channel - Basic ramp-function generator
- 3070 Setpoint channel - Extended ramp-function generator
- 3080 Setpoint channel - Ramp-function generator selection, status word, tracking

Overview of important parameters (see SINAMICS S120/S150 List Manual)

- p1051[0...n] CI: Speed limit in RFG, positive direction of rotation
- p1052[0...n] CI: Speed limit RFG, negative direction of rotation
- p1083[0...n] CO: Speed limit in positive direction of rotation
- p1115 Ramp-function generator selection
- r1119 CO: Ramp-function generator setpoint at the input
- p1120[0...n] Ramp-function generator ramp-up time
- p1121[0...n] Ramp-function generator ramp-down time
- p1122[0...n] BI: Bypass ramp-function generator
- p1130[0...n] Ramp-function generator initial rounding time
- p1131[0...n] Ramp-function generator final rounding time
- p1134[0...n] Ramp-function generator rounding type
- p1135[0...n] OFF3 ramp-down time
- p1136[0...n] OFF3 initial rounding time
- p1137[0...n] OFF3 final rounding time
- p1138[0...n] CI: Ramp-function generator ramp-up time scaling
- p1139[0...n] CI: Ramp-function generator, ramp-down time
- p1140[0...n] BI: Enable ramp-function generator/disable ramp-function generator
- p1141[0...n] BI: Continue ramp-function generator/Freeze ramp-function generator
- p1143[0...n] BI: Accept ramp-function generator setting value
- p1144[0...n] CI: Ramp-function generator setting value
- p1145[0...n] Ramp-function generator tracking intensity
- p1148 [0...n] Ramp-function generator tolerance for ramp-up and ramp-down active
- r1149 CO: Ramp-function generator acceleration
- r1150 CO: Ramp-function generator speed setpoint at the output
- p1151 [0...n] Ramp-function generator configuration
- p1400[0...n] Speed control configuration

Servo control

Definition

This type of closed-loop control enables operation with a high dynamic response and precision for a motor with a motor encoder.

The motor connected to servo control is simulated in a vector model based on data from the equivalent circuit diagram. This means that the servo control is also a vector control.

However, for servo control, the vector model is optimized according to other criteria. In favor of maximum dynamic performance, a small deterioration in the control accuracy and control quality is taken into consideration.

Characteristics of the servo control:

- Maximum computing speed
- Shortest sampling times
- Maximum dynamic performance
- Preferably used with permanent magnet synchronous motors with the appropriate dynamic performance

The servo control can only be operated with an encoder as no model calculation of the actual values is used in the servo control due to the computing speed required.

Comparison of servo control and vector control

The table below shows a comparison between the characteristic features of servo and vector controls.

Table 4- 1 Comparison of servo control and vector control

Subject	Servo control	Vector control
Typical applications	<ul style="list-style-type: none"> • Drives with highly dynamic motion control • Drives with high speed and torque accuracy (servo synchronous motors) • Angular-locked synchronism with isochronous PROFIdrive • For use in machine tools and clocked production machines • High output frequency 	<ul style="list-style-type: none"> • Speed and torque-controlled drives with high speed and torque accuracy, particularly in operation without an encoder (sensorless operation)
Maximum number of drives that can be controlled by one Control Unit To be taken into consideration: Chapter "Rules for wiring with DRIVE-CLiQ (Page 972)" in this document below	<ul style="list-style-type: none"> • 1 infeed + 6 drives (for current controller sampling rates 125 µs or speed controller 125 µs) • 1 infeed + 3 drives (for current controller sampling rates 62.5 µs or speed controller 62.5 µs) • 1 infeed + 1 drive (for current controller sampling rates 31.25 µs or speed controller 62.5 µs) • Mixed operation, servo control with 125 µs with V/f, max.11 drives 	<ul style="list-style-type: none"> • 1 infeed + 3 drives (for current controller sampling times 250 µs or speed controller 1 ms) • 1 infeed + 6 drives (for current controller sampling times 400 µs/500 µs or speed controller 1.6 ms/2 ms) • V/f control: 1 infeed + 12 drives (for current controller sampling times 500 µs or speed controller 2000 µs) • Mixed operation, vector control with 500 µs with V/f, max.11 drives
Dynamic response	High	Medium
Note: Additional information on the sampling conditions is provided in subchapter "Rules regarding sampling times (Page 963)" in this manual.		
Connectable motors	<ul style="list-style-type: none"> • Synchronous servomotors • Permanent-magnet synchronous motors • Induction motors • Torque motors • Linear motors 	<ul style="list-style-type: none"> • Synchronous motors (including torque motors) • Permanent-magnet synchronous motors • Induction motors • Reluctance motors (only for V/f control) • Separately excited synchronous motors • Linear motors <p>Note: Synchronous motors of the 1FT6, 1FK6 and 1FK7 series cannot be connected.</p>
Position interface via PROFIdrive for higher-level motion control	Yes	Yes

Subject	Servo control	Vector control
Encoderless speed control	Yes, as of 10% rated motor speed, open-loop controlled operation below this	Yes (for ASM and PMSM from standstill)
Motor data identification	Yes	Yes
Speed controller tuning	Yes	Yes
V/f control	Yes	Yes (various characteristics)
Encoderless closed-loop torque control	No	Yes, as of 10% rated motor speed, open-loop controlled operation below this
Field-weakening range for induction motors	<ul style="list-style-type: none"> ≤ 16 x field-weakening threshold speed (with encoder) ≤ 5 x field-weakening threshold speed (without encoder) 	≤ 5 x rated motor speed
Maximum output frequency with closed-loop control	<ul style="list-style-type: none"> • 2600 Hz with 31.25 μs / 16 kHz • 1300 Hz with 62.5 μs / 8 kHz • 650 Hz with 125 μs / 4 kHz • 300 Hz with 250 μs / 2 kHz <p>Note: SINAMICS S can achieve the specified values without tuning. Higher frequencies can be set under the following secondary conditions and additional tuning runs:</p> <ul style="list-style-type: none"> • Up to 3000 Hz <ul style="list-style-type: none"> – Operation without an encoder – In conjunction with controlled in-feeds • Up to 3200 Hz <ul style="list-style-type: none"> – Operation with encoder – In conjunction with controlled in-feeds • Absolute upper limit 3200 Hz <p>For frequencies > 600 Hz a license is required as a result of export regulations.</p>	<ul style="list-style-type: none"> • 300 Hz with 250 μs / 4 kHz or with 400 μs / 5 kHz • 240 Hz with 500 μs / 4 kHz <p>Note: If a higher output frequency is required, consult the specialist support from SIEMENS.</p>
<p>Note: The derating characteristics in the various manuals must be carefully observed! Max. output frequency when using dv/dt and sine-wave filters: 150 Hz</p>		
Response when operating at the thermal limit of the motor	Reduction of the current setpoint or shutdown	Reduction in the pulse frequency and / or the current setpoint or shutdown (not applicable with parallel connection / sine-wave filter)

Subject	Servo control	Vector control
Speed setpoint channel (ramp-function generator)	Optional (reduces the number of drives from 6 to 5 Motor Modules for current controller sampling times of 125 μ s - or speed controller sampling times of 125 μ s)	Standard
Parallel connection of power units	No	<ul style="list-style-type: none"> • Booksize: No • Chassis: Yes

4.1 Setpoint addition

Definition

Setpoint addition allows up to 2 speed setpoints to be combined. While main and supplementary setpoints used in the setpoint channel are influenced by speed limits and the ramp-function generator, the speed setpoint is directly active here. As a consequence, up ramps and down ramps of a ramp-function generator are eliminated.

Speed actual values of a higher-level position control are suitable as source, which can be entered using a PROFIdrive telegram. Interconnect the telegram control word as BICO source. The speed setpoint is then refreshed in the bus cycle, e.g. in the PROFINET cycle.

A supplementary speed setpoint can, through setpoint addition, minimize disturbing influences on the speed setpoint from the position control.

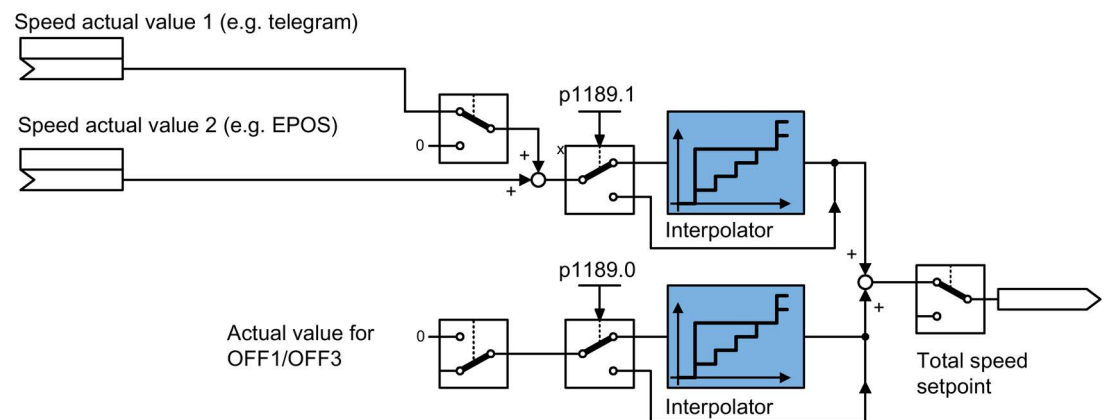

Figure 4-1 Setpoint addition

Interpolator

When using a speed setpoint from a higher-level control system, the speed setpoints are only refreshed (updated) in the bus cycle. The bus cycle is normally significantly slower than the current controller cycle of the SINAMICS drive, which can result in steps. When using an interpolator, the speed setpoint is linearly interpolated between the bus cycles, so that steps that possibly occur can be eliminated.

The interpolator is only active when the "Basic positioner" function module is activated - or isochronous PROFIdrive operation is active.

Parameterizing setpoint addition

1. Interconnect the signal source for p1155.
2. Interconnect the signal source for p1160.
3. To activate the interpolator for the speed setpoint, in the drop-down list for 1189[1] select "yes".

Speed actual value at the OFF1/OFF3 instant

If an event initiates OFF1 or OFF3 - and the "Extended setpoint channel" function module is not active - then the drive ramps down via the OFF1 and OFF3 times parameterized in the "Ramp down" dialog.

1. Enter a value in p1121[0] for the ramp-down time.
2. Enter a value in p1135 for the OFF3 ramp-down time.
3. To activate the interpolator for the down ramp, in the drop-down list for p1189[0], select "Yes". The parameters for the down ramp are only displayed if the extended setpoint channel is deactivated.

Function diagrams (see SINAMICS S120/S150 List Manual)

- 3080 Setpoint channel - ramp-function generator selection, status word, tracking

Overview of important parameters (see SINAMICS S120/S150 List Manual)

- p1121[0...n] Ramp-function generator ramp-down time
- p1135[0...n] OFF3 ramp-down time
- p1155[0...n] Cl: Speed controller, speed setpoint 1
- p1160[0...n] Cl: Speed controller, speed setpoint 2
- p1189[0...n] Speed setpoint configuration

4.2 Speed setpoint filter

Definition

The speed setpoint filters are used to remove or weaken certain frequency ranges. Various filter types are available.

The speed setpoint filters do not have any effect on the stability of the speed controller, because they lie in the setpoint channel. The dynamic response in the control behavior is reduced by the smoothing.

The speed setpoint filters are identical in structure and can be set via parameters p1415[0...n] (filter 1) and p1421[0...n] (filter 2) as follows:

- Bandstop
- Low-pass 1st order (PT1)
- Low-pass 2nd order (PT2)

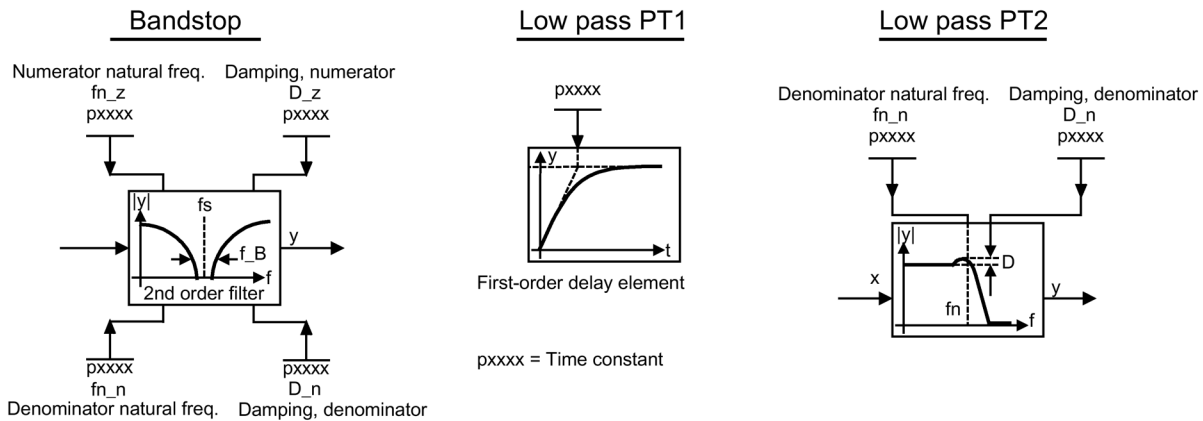

Figure 4-2 Filter overview for speed setpoint filters

Activating and parameterizing the speed setpoint filters via the expert list

You can activate 2 speed setpoint filters in the STARTER expert list using parameter p1414[0...n].

1. Select group parameter p1414[0] and open the sub categorization.
2. Select the required speed setpoint filter - and in the drop-down list of the parameter line, select setting "[1] Yes".

Repeat this procedure for every speed setpoint filter that you wish to additionally activate.

3. For each activated speed setpoint filter (parameter range p1415 ... P1426) parameterize the following values:
 - Type
 - Time constant
 - Denominator natural frequency
 - Denominator damping
 - Numerator natural frequency
 - Numerator damping
4. Then save the modified project settings.

Parameterization with STARTER screen forms

The "Speed setpoint filter" parameter screen form is selected with the  icon in the toolbar of the STARTER commissioning tool.

Function diagrams (see SINAMICS S120/S150 List Manual)

- 5020 Servo control - Speed setpoint filter and speed precontrol

Overview of important parameters (see SINAMICS S120/S150 List Manual)

- p1414[0...n] Speed setpoint filter activation
- p1415[0...n] Speed setpoint filter 1 type
- p1416[0...n] Speed setpoint filter 1 time constant
- p1417[0...n] Speed setpoint filter 1 denominator natural frequency
- p1418[0...n] Speed setpoint filter 1 denominator damping
- p1419[0...n] Speed setpoint filter 1 numerator natural frequency
- p1420[0...n] Speed setpoint filter 1 numerator damping
- p1421[0...n] Speed setpoint filter 2 type
- p1422[0...n] Speed setpoint filter 2 time constant
- p1423[0...n] Speed setpoint filter 2 denominator natural frequency
- p1424[0...n] Speed setpoint filter 2 denominator damping
- p1425[0...n] Speed setpoint filter 2 numerator natural frequency
- p1426[0...n] Speed setpoint filter 2 numerator damping

4.3 Speed controller

4.3.1 Speed controller

The speed controller controls the motor speed using the actual values from the encoder (operation with encoder) or from the calculated actual speed values (operation without encoder).

Properties

- Speed setpoint filter
- Speed controller adaptation

Note

Speed and torque cannot be controlled simultaneously. If speed control is activated, this has priority over torque control.

Limits

The maximum speed p1082[D] is defined with default values for the selected motor and becomes active during commissioning. The ramp-function generator ramp times refer to this value.

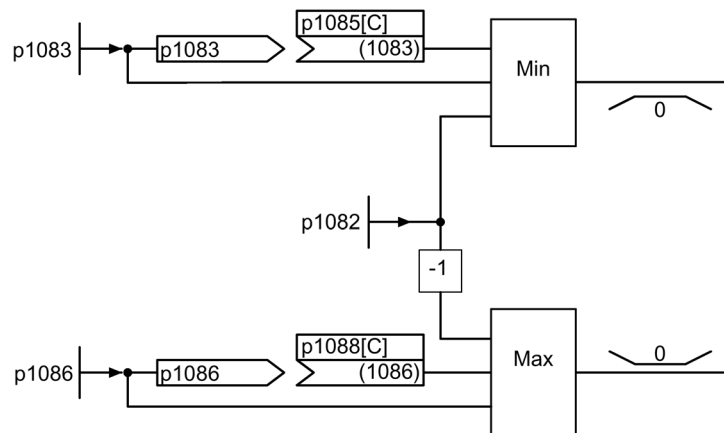

Figure 4-3 Speed controller limitations

4.3.2 Speed controller adaptation

There are two types of adaptation available: The free $K_{p,n}$ adaptation and the speed-dependent $K_{p,n}/T_{n,n}$ adaptation.

Free $K_{p,n}$ adaptation is also active in "operation without encoder" mode and is used in "operation with encoder" mode as an additional factor for speed-dependent $K_{p,n}$ adaptation.

Speed-dependent $K_{p,n}/T_{n,n}$ adaptation is only active in "operation with encoder" mode and also affects the $T_{n,n}$ value.

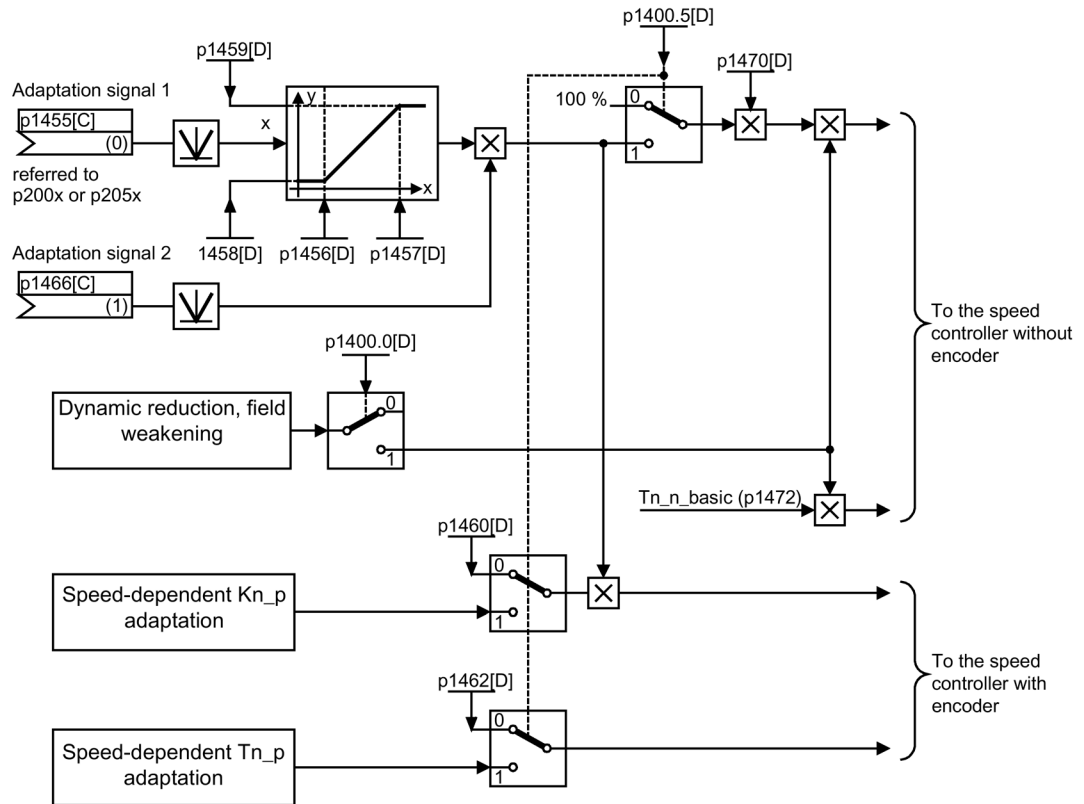

Figure 4-4 Free $K_{p,n}$ adaptation

Example of speed-dependent adaptation

Note

This type of adaptation is only active when the drive is operated with an encoder!

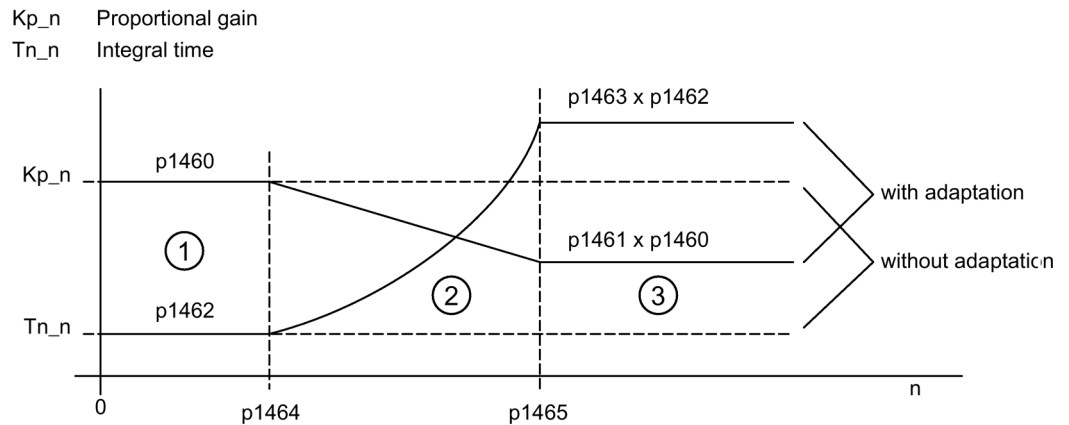



Figure 4-5 Speed controller- K_{p_n}/T_{n_n} adaptation

Parameterization with STARTER

The "Speed controller" parameter screen is selected with the  icon in the toolbar of the STARTER commissioning tool.

Function diagrams (see SINAMICS S120/S150 List Manual)

- 5050 Servo control - Speed controller adaptation (K_{p_n}/T_{n_n} adaptation)

Overview of important parameters (see SINAMICS S120/S150 List Manual)

Free K_{p_n} adaptation

- p1455[0...n] CI: Speed controller P gain adaptation signal
- p1456[0...n] Speed controller P gain adaptation lower starting point
- p1457[0...n] Speed controller P gain adaptation upper starting point
- p1458[0...n] Lower adaptation factor
- p1459[0...n] Upper adaptation factor

Speed-dependent K_{p_n}/T_{n_n} adaptation

- p1460[0...n] Speed controller P gain adaptation speed, lower
- p1461[0...n] Speed controller Kp adaptation speed, upper scaling
- p1462[0...n] Speed controller integral time adaptation speed, lower
- p1463[0...n] Speed controller Tn adaptation speed, upper scaling
- p1464[0...n] Speed controller adaptation speed, lower
- p1465[0...n] Speed controller adaptation speed, upper
- p1466[0...n] CI: Speed controller P gain scaling

4.3.3 Torque-controlled operation

An operating mode switchover (p1300) or binector input (p1501) can be used to switch from speed control to torque control mode. All torque setpoints from the speed control system are rendered inactive. The setpoints for torque control mode are selected by parameterization.

Properties

- Switchover to torque control mode via:
 - Operating mode selection
 - Binector input
- Torque setpoint can be specified:
 - The torque setpoint source can be selected
 - The torque setpoint can be scaled
 - An additional torque setpoint can be entered
- Display of the overall torque

Commissioning of torque control mode

1. Set the torque-controlled mode 1300 = 23; p1501 = "1" signal)
2. Enter the torque setpoint using the following parameter:
 - p1511: Signal source for supplementary torque 1
 - p1512: Signal source for scaling supplementary torque 1.
 - p1513: Signal source for supplementary torque 2

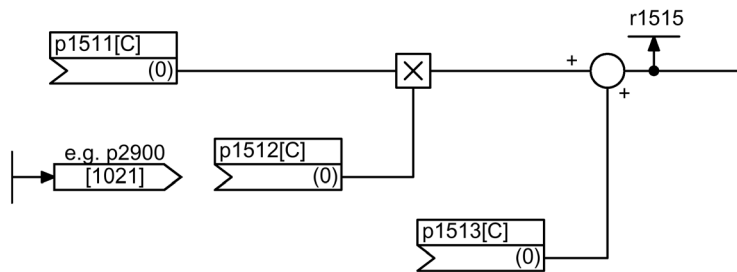



Figure 4-6 Torque setpoint

3. Issue the enable signals.

OFF responses

- OFF1 and p1300 = 23
 - Response as for OFF2
- OFF1, p1501 = "1" signal and p1300 ≠ 23
 - No separate braking response; the braking response is provided by a drive that specifies the torque.
 - The pulses are suppressed when the brake application time (p1217) expires. Standstill is detected when the actual speed value is less than the speed threshold (p1226) or when the monitoring time (p1227) that started when speed setpoint ≤ speed threshold (p1226) has expired.
 - Switching-on inhibited is activated.
- OFF2
 - Immediate pulse suppression, the drive coasts to standstill.
 - The motor brake (if parameterized) is closed immediately.
 - Switching-on inhibited is activated.
- OFF3
 - Switch to speed-controlled operation
 - n_set = 0 is input immediately to brake the drive along the OFF3 deceleration ramp (p1135).
 - When standstill is detected, the motor brake (if parameterized) is closed.
 - The pulses are suppressed when the motor brake application time (p1217) has elapsed. Standstill is detected when the actual speed value is less than the speed threshold (p1226) or when the monitoring time (p1227) that started when speed setpoint ≤ speed threshold (p1226) has expired.
 - Switching-on inhibited is activated.

Parameterization with STARTER

The "Torque setpoint" parameter screen is selected with the  icon in the toolbar of the STARTER commissioning tool.

Function diagrams (see SINAMICS S120/S150 List Manual)

- 5060 Servo control - Torque setpoint, switchover control mode
- 5610 Servo control – torque limiting/reduction, interpolator

Overview of important parameters (see SINAMICS S120/S150 List Manual)

- p1300[0...n] Open-loop/closed-loop control operating mode
- r1406.8...12 CO/BO: Control word, speed controller
- p1501[0...n] BI: Change over between closed-loop speed/torque control
- p1511[0...n] CI: Supplementary torque 1
- p1512[0...n] CI: Supplementary torque 1 scaling
- p1513[0...n] CI: Supplementary torque 2
- r1515 Supplementary torque total

4.4 Torque setpoint limitation

The steps required for limiting the torque setpoint are as follows:

- Define the torque setpoint and an additional torque setpoint
- Generate torque limits

The torque setpoint can be limited to a maximum permissible value in all four quadrants. Different limits can be parameterized for motor and regenerative modes.

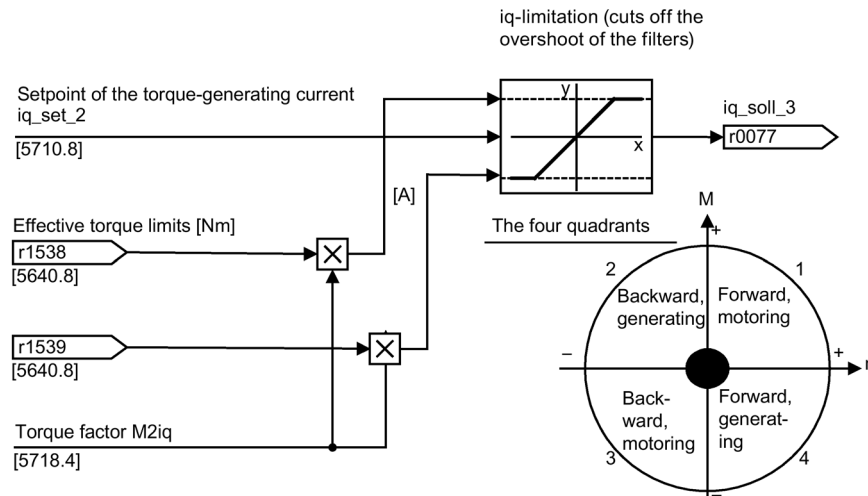

Figure 4-7 Current/torque setpoint limiting

Note

This function is always active with the preset factory settings.

Properties

The connector inputs of the function are initialized with fixed torque limits. If required, the torque limits can also be defined dynamically (during operation).

- A control bit can be used to select the torque limitation mode. The following alternatives are available:
 - Upper and lower torque limit
 - Motor and regenerative torque limit
- Additional power limitation configurable
 - Motor mode power limit
 - Regenerative mode power limit

- The following factors are monitored by the current controller and therefore always apply in addition to torque limitation:
 - Stall power
 - Maximum torque-generating current
- Offset of the setting values also possible (see "Example: Torque limits with or without offset").
- The following torque limits are displayed via parameters:
 - Lowest of all upper torque limits with and without offset
 - Highest of all lower torque limits with and without offset

Torque limiting versions

The following versions are available:

- No settings are possible:

The application does not require any additional restrictions to the torque limits.
- Fixed limits are required for the torque:

The fixed upper and lower limits or alternatively the fixed motor and regenerative limits can be specified separately from different sources.
- Dynamic limits are required for the torque:
 - The dynamic upper and lower limits or alternatively the dynamic motor and regenerative limit can be specified separately from different sources.
 - Parameters are used to select the source of the actual limit.
- A torque offset can be parameterized.
- In addition, the power limits can be parameterized independently of one another for motor and regenerative mode.

Negative values at r1534 or positive values at r1535 represent a minimum torque for the other torque directions and can cause the drives to rotate if no counteractive load torque is generated (see function diagram 5630 in the SINAMICS S120/S150 List Manual).

 WARNING
Risk of injury resulting from uncontrolled drive motion due to incorrect parameterization
If there is no opposing (load) torque, incorrect parameterization of the torque limits can result in uncontrolled drive motion, therefore resulting in death or severe injury.
<ul style="list-style-type: none">• Ensure that the limits are correctly parameterized.

Example: Torque limits with or without offset

The signals selected using p1522 and p1523 include the torque limits parameterized using p1520 and p1521.

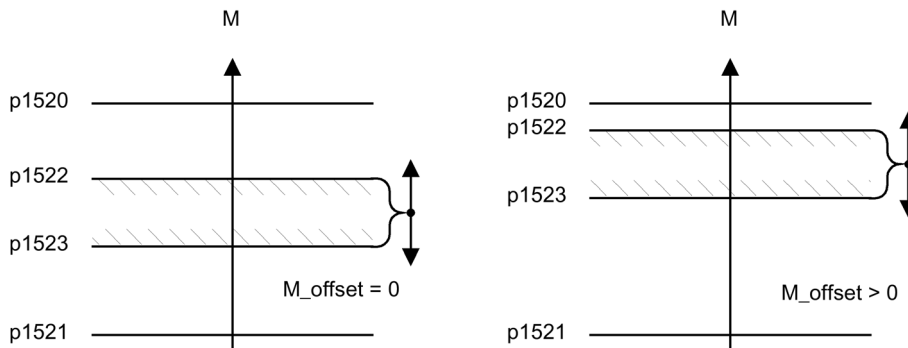

Figure 4-8 Example: Torque limits with or without offset

The hatched area in the example shows the permissible torque range.

Fixed and variable torque limit settings

Table 4- 2 Fixed and variable torque limit settings

Selection	Torque limitation mode			
	Maximum upper or lower torque limits p1400.4 = 0		Maximum motor or regenerative mode torque limits p1400.4 = 1	
Fixed torque limit	Upper torque limit (as positive value)	p1520	Motor mode torque limit (as positive value)	p1520
	Lower torque limit (as negative value)	p1521	Regenerative mode torque limit (as negative value)	p1521
Source for variable torque limit	Upper torque limit	p1522	Motor mode torque limit	p1522
	Lower torque limit	p1523	Regenerative mode torque limit	p1523
Source for variable scaling factor of torque limit	Upper torque limit	p1528	Motor mode torque limit	p1528
	Lower torque limit	p1529	Regenerative mode torque limit	p1529
Torque offset for torque limit	Shifts the upper and lower torque limits together	p1532	Shifts the motor and regenerative mode torque limits together	p1532

Activating the torque limits

1. Select the source for torque limiting via parameter (see Table "Setting fixed and variable torque limits").
2. Specify the torque limiting mode via the control word.
3. If required, make the following settings:
 - Select and activate additional limitations.
 - Set the torque offset.

Examples

- Travel to fixed stop
- Tension control for continuous goods conveyors and winders

Parameterization with STARTER

The "Torque limit" parameter screen is selected with the  icon in the toolbar of the STARTER commissioning tool.

Function diagrams (see SINAMICS S120/S150 List Manual)

- 5609 Servo control, generation of the torque limits, overview
- 5610 Servo control – torque limiting/reduction, interpolator
- 5620 Servo control - Motoring/generating torque limit
- 5630 Servo control - Upper/lower torque limit
- 5640 Servo control - Mode changeover, power/current limiting

Overview of important parameters (see SINAMICS S120/S150 List Manual)

- p0640[0...n] Current limit
- p1400[0...n] Speed control configuration
- r1508 CO: Torque setpoint before supplementary torque
- r1509 CO: Torque setpoint before torque limiting
- r1515 Supplementary torque total
- p1520[0...n] CO: Torque limit, upper/motoring
- p1521[0...n] CO: Torque limit, lower/regenerative
- p1522[0...n] CI: Torque limit, upper/motoring
- p1523[0...n] CI: Torque limit, lower/regenerative
- r1526 CO: Torque limit, upper/motoring without offset
- r1527 CO: Torque limit, lower/regenerative without offset
- p1528[0...n] CI: Torque limit, upper/motoring, scaling
- p1529[0...n] CI: Torque limit, lower/regenerative scaling
- p1530[0...n] Power limit, motoring
- p1531[0...n] Power limit, regenerative
- p1532[0...n] CO: Torque limit, offset
- r1533 Current limit torque-generating, total
- r1534 CO: Torque limit, upper total
- r1535 CO: Torque limit, lower total
- r1538 CO: Upper effective torque limit
- r1539 CO: Lower effective torque limit

4.5 Current setpoint filter

Activate and set current setpoint filter

The current setpoint filters 1 to 4 are available as standard. You can activate the current setpoint filters 5 to 10 offline in the object properties of the drive.

1. If you require more than 4 current setpoint filters, mark the desired servo drive in the project navigator and open the "Properties" shortcut menu.

The "Object properties" dialog then opens.

2. Click the "Function modules" tab.
3. Activate the "Extended current setpoint filters" function module in the function modules selection with a mouse click.
4. Download the data to the target system.
5. Select group parameter p1656[0] online and open the sub categorization.
6. Select the required current setpoint filter (e.g. P1656[0].0) - and in the drop-down list of the parameter line, select setting "[1] Active".

Repeat this procedure for every speed setpoint filter that you wish to additionally activate.

7. If you require more than 4 current setpoint filters, select group parameter p5200[0] and open the sub-categorization.
8. Select the required additional current setpoint filter, in the parameter line, open the value selection and select setting "[1] Active".

Repeat this procedure for every additional speed setpoint filter that you wish to activate.

9. The activated current setpoint filters must then be subsequently parameterized.

Current setpoint filter	Setting in the parameter area
1 ... 4	p1657 to p1676
5 ... 10	p5201 to p5230

For each activated current setpoint filter, parameterize the following values:

- Type
- Denominator natural frequency
- Denominator damping
- Numerator damping

As long as the parameter setting p1699 = 1 is active, the background calculation of the filter data is not performed, even when filter parameters are changed.

Note

The set parameter values of the current setpoint filters 5 to 10 are lost if you deactivate the extended current setpoint filters again in the Properties dialog.

10. Make the setting p1699 = 0 to start calculating the filter data.
11. Then save the modified project settings.

Parameterization example

Four current setpoint filters connected in series can be parameterized as follows, for example:

- Lowpass 2nd order (PT2: -40 dB/decade) (type 1)
- General filter 2nd order (type 2)
- Bandstop
- Low-pass with reduction by a constant value

Bandstop and low-pass with reduction are converted into the parameters of the general 2nd order filter via the STARTER commissioning tool.

In addition to the amplitude response, the phase response is also shown in the following. A phase shift results in a control system delay and should be kept to a minimum.

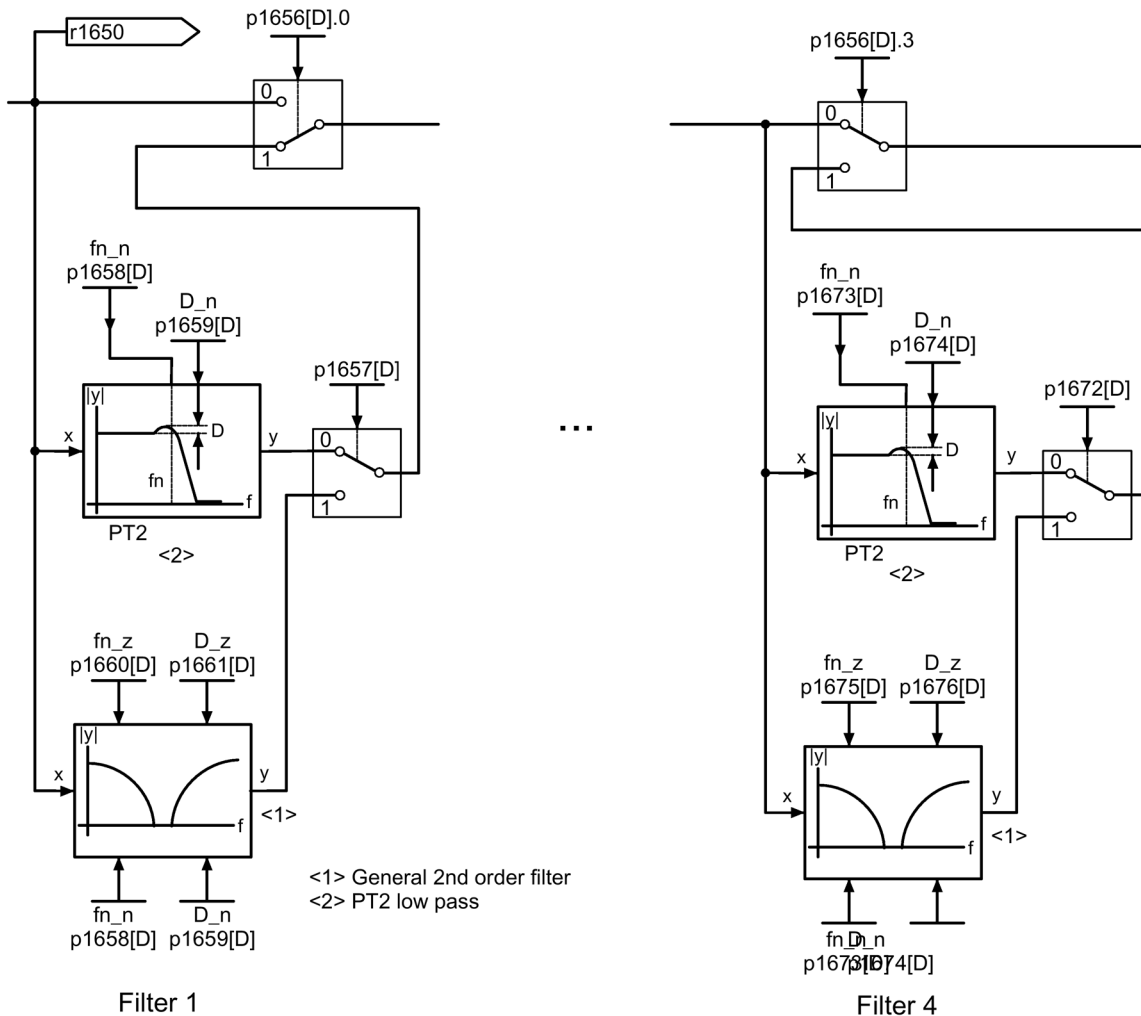



Figure 4-9 Current setpoint filter

Parameterization with STARTER

The "Current setpoint filter" parameter screen is selected with the  icon in the toolbar of the STARTER commissioning tool.

4.5.1 Lowpass 2nd order (PT2 filter)

Transfer function:

$$H_{(s)} = \frac{1}{\left(\frac{s}{2\pi f_N}\right)^2 + \frac{2D_N}{2\pi f_N} \cdot s + 1}$$

Denominator natural frequency f_N
 Denominator damping D_N

Table 4- 3 Example of a PT2 filter

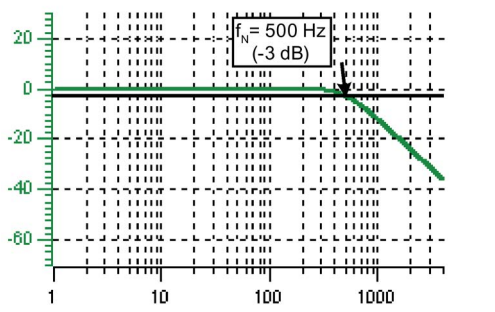
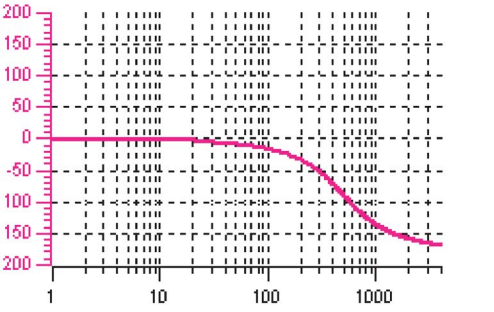
STARTER filter parameters	Amplitude log frequency curve	Phase frequency curve
Characteristic frequency f_N 500 Hz Damping D_N 0.7 dB	 <p>The graph shows a green line representing the amplitude response. The x-axis is frequency in Hz on a logarithmic scale from 1 to 1000. The y-axis is gain in dB from -60 to 20. A horizontal line is drawn at 0 dB. A point on the curve is marked with a box: $f_N = 500 \text{ Hz}$ (-3 dB). The curve starts at 0 dB at 1 Hz and decreases to approximately -40 dB at 1000 Hz.</p>	 <p>The graph shows a pink line representing the phase response. The x-axis is frequency in Hz on a logarithmic scale from 1 to 1000. The y-axis is phase in degrees from -200 to 200. The curve starts at 0 degrees at 1 Hz and decreases to approximately -180 degrees at 1000 Hz.</p>

4.5.2 Bandstop with infinite notch depth

Table 4- 4 Example of band-stop with infinite notch depth

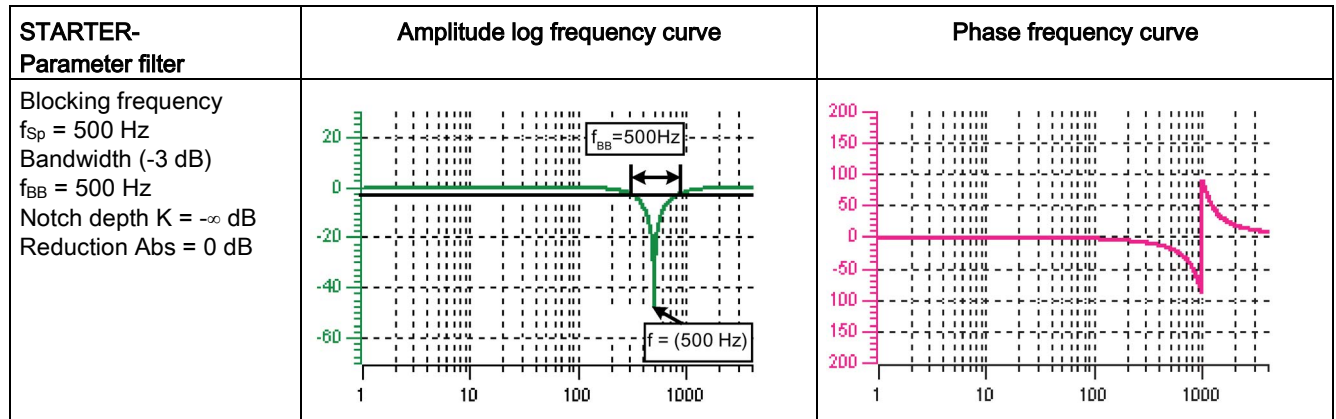

Simplified conversion to parameters for general order filters:

- Reduction or increase after the blocking frequency (Abs)
- Infinite notch depth at the blocking frequency
- Numerator natural frequency $f_z = f_{Sp}$
- Numerator damping $D_z = 0$
- Denominator natural frequency $f_N = f_{Sp}$
- Denominator damping:

$$D_N = \frac{f_{BB}}{2 \cdot f_{Sp}}$$

4.5.3 Bandstop with defined notch depth

Table 4- 5 Example of band-stop with defined notch depth

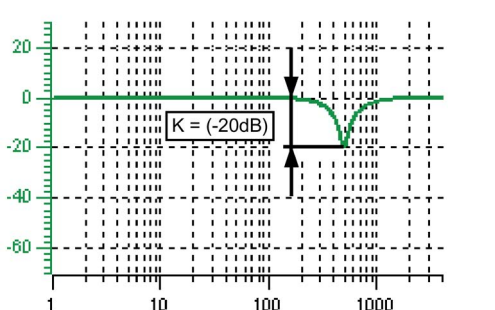
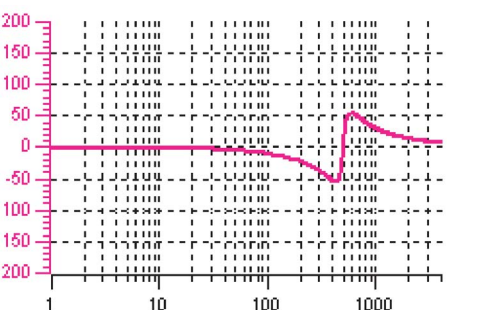
STARTER-Parameter filter	Amplitude log frequency curve	Phase frequency curve
Blocking frequency $f_{Sp} = 500$ Hz Bandwidth $f_{BB} = 500$ Hz Notch depth $K = -20$ dB Reduction Abs = 0 dB		

Simplified conversion to parameters for general order filters:

- No reduction or increase after the blocking frequency
- Defined notch at the blocking frequency K [dB] (e.g. -20 dB)
- Numerator natural frequency $f_z = f_{Sp}$
- Numerator damping:

$$D_z = \frac{f_{BB}}{2 \cdot f_{Sp} \cdot 10^{\frac{K}{20}}}$$

- Denominator natural frequency $f_N = f_{Sp}$
- Denominator damping:

$$D_N = \frac{f_{BB}}{2 \cdot f_{Sp}}$$

4.5.4 Bandstop with defined reduction

Table 4- 6 Example of band-stop

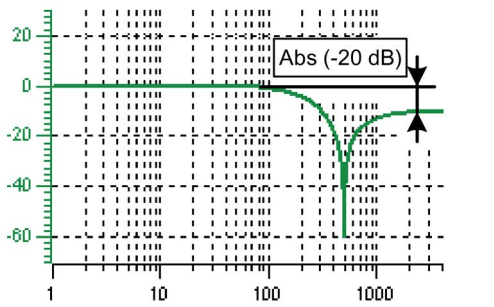
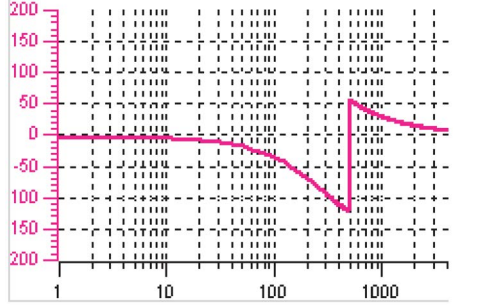
STARTER- Parameter filter	Amplitude log frequency curve	Phase frequency curve
Blocking frequency $f_{SP} = 500 \text{ Hz}$ Bandwidth $f_{BB} = 500 \text{ Hz}$ Notch depth $K = -\infty \text{ dB}$ Reduction ABS = -10 dB		

General conversion to parameters for general order filters:

- Numerator natural frequency:

$$f_Z = \frac{\omega_Z}{2\pi} = f_{SP}$$

- Numerator damping:

$$D_Z = 10^{\frac{K}{20}} \cdot \frac{1}{2} \cdot \sqrt{\left(1 - \frac{1}{10^{\frac{Abs}{20}}}\right)^2 + \frac{f_{BB}^2}{f_{SP}^2 \cdot 10^{\frac{Abs}{10}}}}$$

- Denominator natural frequency:

$$f_N = \frac{\omega_N}{2\pi} = f_{SP} \cdot 10^{\frac{Abs}{40}}$$

- Denominator damping:

$$D_N = \frac{f_{BB}}{2 \cdot f_{SP} \cdot 10^{\frac{Abs}{40}}}$$

4.5.5 General low-pass with reduction

Table 4- 7 Example of general low-pass with reduction

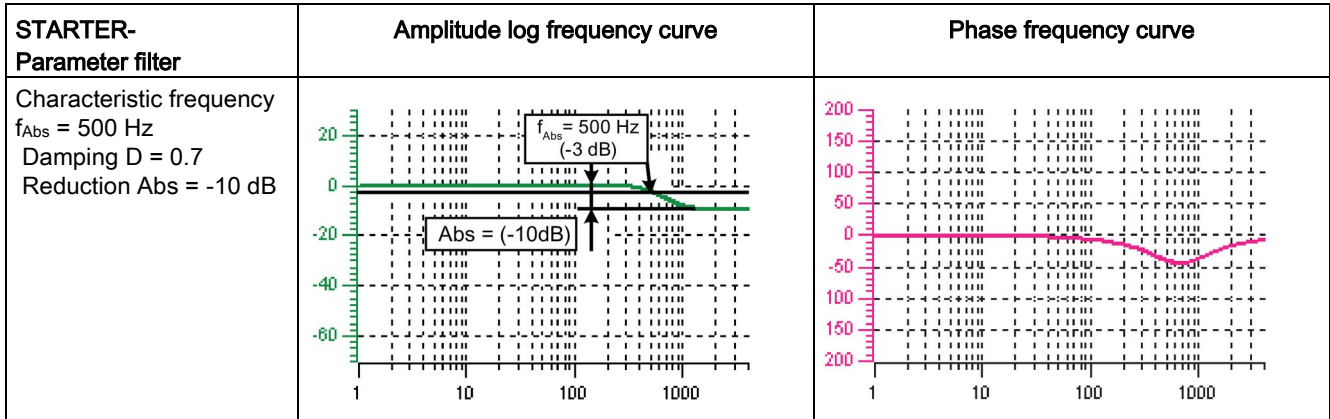

Conversion to parameters for general order filters:

- Numerator natural frequency $f_z = f_{Abs}$ (start of reduction)
- Numerator damping:

$$f_z = \frac{f_{Abs}}{10^{\frac{Abs}{40}}}$$

- Denominator natural frequency f_N
- Denominator damping D_N

4.5.6 Transfer function general 2nd order filter

$$H(s) = \frac{\left(\frac{s}{2\pi f_z}\right)^2 + \frac{2D_z}{2\pi f_z} \cdot s + 1}{\left(\frac{s}{2\pi f_N}\right)^2 + \frac{2D_N}{2\pi f_N} \cdot s + 1}$$

Numerator natural frequency f_z

Numerator damping D_z

Denominator natural frequency f_N

Denominator damping D_N

Table 4- 8 Example of general 2nd order filter

STARTER- Parameter filter	Amplitude log frequency curve	Phase frequency curve
Numerator frequency $f_z = 500$ Hz Numerator damping $D_z = 0.02$ dB Denominator frequency $f_N = 900$ Hz Denominator damping $D_N = 0.15$ dB	<p>The graph shows the magnitude response in dB versus frequency in Hz on a logarithmic scale. A resonance peak is observed at $f_N = 900$ Hz, reaching approximately 20 dB. A zero is located at $f_z = 500$ Hz, where the magnitude drops to about -40 dB. The plot is on a grid with frequency from 1 to 1000 Hz and magnitude from -80 to 20 dB.</p>	<p>The graph shows the phase response in degrees versus frequency in Hz on a logarithmic scale. The phase starts at 0 degrees at low frequencies, drops to a minimum of approximately -150 degrees at the resonance frequency of 900 Hz, and then rises back towards 0 degrees at higher frequencies. The plot is on a grid with frequency from 1 to 1000 Hz and phase from -200 to 200 degrees.</p>

4.5.7 Function diagrams and parameters

Function diagrams (see SINAMICS S120/S150 List Manual)

- 5700 Servo control - Current control, overview
- 5710 Servo control - Current setpoint filters 1 ... 4
- 5711 Servo control - Current setpoint filters 5 ... 10 (r0108.21 = 1)

Overview of important parameters (see SINAMICS S120/S150 List Manual)

- p0108[0...n] Drive object function module
- p1400[0...n] Speed control configuration
- p1656[0...n] Current setpoint filter activation
- p1657[0...n] Current setpoint filter 1 type
- p1658[0...n] Current setpoint filter 1 denominator natural frequency
- p1659[0...n] Current setpoint filter 1 denominator damping
- p1660[0...n] Current setpoint filter 1 numerator natural frequency
- p1661[0...n] Current setpoint filter 1 numerator damping
- p1662[0...n] to p1666[0...n] Current setpoint filter 2 (for distribution see current setpoint filter 1)
- p1667[0...n] to p1671[0...n] Current setpoint filter 3 (for distribution see current setpoint filter 1)
- p1672[0...n] to p1676[0...n] Current setpoint filter 4 (for distribution see current setpoint filter 1)
- p1699 Filter data acceptance
- p5200[0...n] Current setpoint filter 5 ... 10 activation
- p5201[0...n] to p5205[0...n] Current setpoint filter 5 (for distribution see current setpoint filter 1)
- p5206[0...n] to p5210[0...n] Current setpoint filter 6 (for distribution see current setpoint filter 1)
- p5211[0...n] to p5215[0...n] Current setpoint filter 7 (for distribution see current setpoint filter 1)
- p5216[0...n] to p5220[0...n] Current setpoint filter 8 (for distribution see current setpoint filter 1)
- p5221[0...n] to p5225[0...n] Current setpoint filter 9 (for distribution see current setpoint filter 1)
- p5226[0...n] to p5230[0...n] Current setpoint filter 10 (for distribution see current setpoint filter 1)

4.6 Current controller

Generally, the current controller is only required for the first commissioning. No additional settings are required in normal operation. You can further optimize the current controller settings for special application.

Characteristics of the current controller

- Current controller acts as PI controller.
- 4 current setpoint filters
- Current and torque limitation
- Current controller adaptation is possible
- Closed-loop flux control is possible for an induction motor

Current and torque limitation

The current and torque limitations are initialized when the system is commissioned for the first time and should be adjusted according to the application.

Current controller adaptation

The P gain of the current controller can be reduced (depending on the current) by means of current controller adaptation. Current controller adaptation can be deactivated with the setting $p1402.2 = 0$.

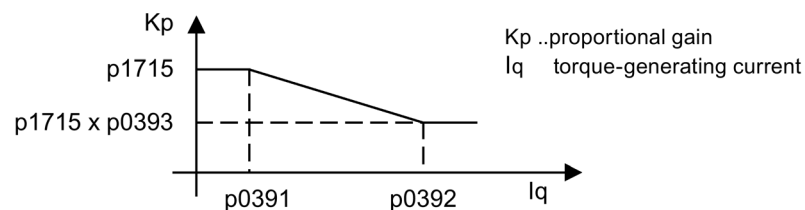



Figure 4-10 Current controller adaptation

Flux controller (for induction motor)

The parameters for the flux controller are initialized when the system is commissioned for the first time and do not need to be adjusted.

Commissioning with STARTER

The "Current controller" parameter screen is selected with the  icon in the toolbar of the STARTER commissioning tool.

Function diagrams (see SINAMICS S120/S150 List Manual)

- 5700 Servo control - Current control, overview
- 5710 Servo control - Current setpoint filter 1 ... 4
- 5714 Servo control - Iq and Id controller
- 5722 Servo control - Field current / flux specification, flux reduction, flux controller

Overview of important parameters (see SINAMICS S120/S150 List Manual)

Current control

- p1701[0...n] Current controller reference model dead time
- p1715[0...n] Current controller P gain
- p1717[0...n] Current controller integral time

Current and torque limitation

- p0323[0...n] Maximum motor current
- p0326[0...n] Motor stall torque correction factor
- p0640[0...n] Current limit
- p1520[0...n] CO: Torque limit, upper/motoring
- p1521[0...n] CO: Torque limit, lower/regenerative
- p1522[0...n] CI: Torque limit, upper/motoring
- p1523[0...n] CI: Torque limit, lower/regenerative
- p1524[0...n] CO: Torque limit, upper/motoring, scaling
- p1525[0...n] CO: Torque limit, lower/regenerative scaling
- r1526 CO: Torque limit, upper/motoring without offset
- r1527 CO: Torque limit, lower/regenerative without offset
- p1528[0...n] CI: Torque limit, upper/motoring, scaling
- p1529[0...n] CI: Lower or regenerative torque limit scaling
- p1530[0...n] Power limit, motoring
- p1531[0...n] Power limit, regenerative
- p1532[0...n] CO: Torque limit, offset
- r1533 Current limit torque-generating, total
- r1534 CO: Torque limit, upper total
- r1535 CO: Torque limit, lower total
- r1538 CO: Upper effective torque limit
- r1539 CO: Lower effective torque limit

Current controller adaptation

- p0391[0...n] Current controller adaptation, starting point KP
- p0392[0...n] Current controller adaptation, starting point KP adapted
- p0393[0...n] Current controller adaptation, P gain adaptation
- p1590[0...n] Flux controller P gain
- p1592[0...n] Flux controller integral time

4.7 Autotuning

The term "Autotuning" comprises all drive-internal functions that adapt controller parameters during operation based on internal measured variables.

The main applications of the autotuning functions are:

- Support of the commissioning
- Adaptation of the controller during major changes in the mechanical system

The set parameters are visible in the parameters, but not saved permanently.

Overview of the most important autotuning process

Processes	Servo control	Vector control	Explanation
Speed controller optimization:	-	X	With p1960 = 3.4 the total moment of inertia is measured and the speed controller and acceleration precontrol are set as a result.
Automatic controller setting	X	-	The speed controller is set automatically via the STARTER with this process. Filters are set automatically in the current setpoint arm (e.g. for damping resonance) via the automatic controller setting on the speed controller.
One button tuning	X	-	With servo control the speed and EPOS controller can be optimized with this optimization process. A control system is measured once and the controllers are set as a result.
Online tuning	X	-	With this optimization process the controller parameters are determined from the constant estimated or parameterized moments of inertia (motor torque and moment of inertia). It is recommended in all cases where EPOS is used. Online tuning can also be set if the engineering tool (e.g. STARTER) cannot be used upon commissioning to optimize the EPOS position controller. If the measurement/optimization is not required on a constant basis then deactivating online tuning again once the controller data has been calculated and then permanently saving the values determined for the controller optimization and the filter settings (RAM to ROM) is recommended.
Current setpoint filter adaptation	X	-	The current setpoint filter adaptation is provided for systems that display a variable mechanical resonance frequency during operation. This way a selected current setpoint filter can be automatically shifted to a mechanical resonance frequency.

4.7.1 One button tuning

The speed controller and position controller of a drive can be automatically tuned with the "One button tuning" function. This is a drive-internal function. Therefore, no external engineering tool is required. With "One button tuning", the mechanical drive train is measured with the aid of short test signals. In this way, the controller parameters can be optimally adapted to the existing mechanical system.

NOTICE
Material damage as a result of an unstable controller when manually changing the controller parameters during autotuning
If you wish to manually change a controller parameter, that the "One Button Tuning" automatically sets, then this can result in an unstable controller and therefore material damage.
<ul style="list-style-type: none"> Therefore, do not change the following parameters during the One Button Tuning: p0430, p1160, p1413 - p1426, p1428, p1429, p1433 - p1435, p1441 , p1460 - p1465, p1498, p1513, p1656 - p1676, p2533 - p2539, p2567, p2572, p2573.

Restrictions:

Only the motor measuring system is taken into account when optimizing the position controller. If an external measuring system is used for the position control, this can result in an unstable controller setting. The "One button tuning" function also does not support different sampling times for current controller and torque/speed controller. It is recommended not to use the "One button tuning" function with this configuration.

Activating autotuning

You can configure the activation and deactivation of the autotuning function via parameter p5300. The following settings are possible:

Setting	Explanation
-1	The "Autotuning" function is set inactive. The setting is automatically corrected to p5300 = 0. The default settings for the speed controller and position controller are also restored.
0	The "Autotuning" function is set inactive. The current setting of all controller parameters are retained as volatile values. The parameters must be saved in the non-volatile memory for permanent storage of the values determined for the speed controller and position controller (p0977 = 1 or RAM after ROM).
1	The "One button tuning" function is active. A new calculation of the controller parameters is performed once after the end of the one button tuning. p5300 = 0 is then set.
2	The "Online tuning" function is active. A new calculation of the controller parameters is performed cyclically if the estimated moment of inertia changes.

Note

Changing parameter p5300 changes parameters p5280 and p1400. Therefore after deactivating the autotuning function check the accuracy of the configuration of parameters p5280 and p1400 and amend these if required.

Configuring the "One button tuning"

The following settings are possible via p5301:

Bit	Effect
00	The speed controller gain is determined and set with the aid of a noise signal.
01	Any required current setpoint filters are determined and set with the aid of a noise signal. In this way, a higher dynamic response can be achieved in the speed control loop.
02	With this bit, the moment of inertia is determined with the aid of a test signal. If this bit is not set, the load moment of inertia must be parameterized manually in parameter p1498. The test signal must first be set with parameters p5308 and p5309.
04	Possibly existing load oscillations (low-frequency resonance) are determined using a test signal. The function detects frequencies in the range of approx. 2Hz to 95Hz. No external measuring system is required for the load. The frequencies detected (zero positions and pole positions) are displayed in p5294[0...2] and p5295[0...2]. A sufficiently large traversing distance must be preset using parameter p5308 for this function.
05	In addition to the loan oscillation detection (see bit 04) an active attenuation is configured for the load oscillation detected. In doing so, the frequency of the smallest zero position is automatically entered in p3752. A requirement for this is the function module "Advanced Positioning Control" (r0108.7 = 1) and p3700.2 = 1. The load moment of inertia must also be determined using p5301.2 - or first manually entered in p1498. After the function is performed, Advanced Positioning Control must be activated by setting p3700.0 to 1.
07	With this function, these axes are adapted to the dynamic response set in p5275. This is required for interpolating axes. The time in p5275 should be set with the lowest dynamic response in accordance with the axis.

Additional settings and displays

Parameter	Adjustment range	Factory setting	Setting/display
p5292	25 %...125%	80%	Dynamic response factor for the P gain of the speed controller. The speed control may become instable if the values are too high.
r5293	-	-	Display of the determined proportional gain of the speed controller calculated from the FFT measurement through "One button tuning".
r5294	-	-	Display of the identified mechanical zero positions.
r5295	-	-	Display of the identified mechanical pole positions.
p5296[0]	1%...300%	10%	Setting the amplitude of the noise signal for the functions p5301.0 and p5301.1. The value refers to the rated torque of the motor r0333.
p5296[1]	1%...300%	30%	Setting the amplitude of the noise signal for the functions p5301.4 and p5301.5. The value refers to the rated torque of the motor r0333.
p5297[0]	-210000...210000 rpm -210000...210000 m/min	0 rpm 0 m/min	Setting the rotational feed offset for the functions p5301.0 and p5301.1. This should prevent non-linear effects, such as backlash or stiction, influencing the measured values.
p5297[1]	-210000...210000 rpm -210000...210000 m/min	0 rpm 0 m/min	Setting the rotational feed offset for the functions p5301.4 and p5301.5. This should prevent non-linear effects, such as backlash or stiction, influencing the measured values.
p5308	0...30000 degrees 0...30000 mm	0 degree 0 mm	Distance limit for "One button tuning". After activating the "One button tuning" (p5300), the traversing range in the positive and negative directions is limited to the set distance limit in degrees. A value of 360 degrees corresponds to one motor revolution.
p5309	0 ms...5000 ms	2000 ms	Complete test signal (triangular).

Automatic pre-assignment

When the "One button tuning" function is activated, settings are made that should ensure the safe and dynamic operation of the drive.

The mechanical drive train is measured with the aid of test signals. In this way, the controller parameters can be calculated so that the drive train is set as dynamically as possible.

The test signals comprise, on the one hand, a noise excitation during which the drive executes a motion with a superimposed noise signal for a few seconds. The following settings are required for this:

- The speed controller gain is set with $p5301.0 = 1$.
Parameter $p5292$ is a multiplier for this gain. An amplitude reserve of 7 dB and 45° phase margin is taken into account with $p5292 = 100\%$.
- Current setpoint filters 1...4 are parameterized with $p5301.1 = 1$.
These filters are set in order to achieve greater gains in the speed control loop. Typically, bandstop filters are applied to mechanical resonances. Filters are only set when a greater speed controller gain $p1460$ can be achieved.
- Active oscillation damping is parameterized by setting $p5301.5$ to 1.
The frequency of the load oscillation detected is set in $p3752$ "Advanced positioning control closed-loop controller pre-assignment for natural frequency of vibration". A requirement for this is the function module "Advanced Positioning Control" ($r0108.7 = 1$) and $p3700.2 = 1$. The load moment of inertia must also be determined using $p5301.2$ - or first manually entered in $p1498$. Following this, Advanced Positioning Control must be activated by setting $p3700.0$ to 1. An existing load oscillation can be dampened during the positioning action using the oscillation damping control. Due to the spring moment feedback, the synchronous operation could be worsened, which can have a negative effect.

On the other hand, a very low frequency speed setpoint signal (triangular) is applied to the drive. The motor makes a clearly visible movement. Distance amplitude and duration must be set with parameters $p5308$ and $p5309$.

In this way, the moment of inertia of the drive train is estimated. All the remaining controller parameters are set. The setting is performed in the same way as for "Online tuning".

4.7.2 Online tuning

4.7.2.1 "Drive-based" online tuning

The "Online tuning" can be used with EPOS for simple positioning tasks. With the "Online tuning" function, it is possible to automatically set robust controller parameters of a drive during operation without user interaction. Through the online tuning, the relevant controller parameters for the speed controller and position controller including precontrol are set automatically. The automatic calculation of the controller parameters also depends on the moment of inertia of the motor and the load. The load moment of inertia (p1498) can either be parameterized manually or determined once or cyclically by activating the inertia estimator (Page 548).

Note

The "Online tuning" function is activated via the "Inertia estimator (Page 548)" function module.

NOTICE

Material damage caused by an unstable controller for excessively low stiffness between the motor and load

Only the motor measuring system is taken into account for the calculation of the controller parameters.

If a load-side measuring system is used for the position control, this can result in an unstable controller setting if the motor shaft is not adequately stiff and there is a relatively high load moment of inertia – which in turn can lead to material damage.

- If the stiffness is too low, reduce the load dynamic factor using p5273.
- For all DDS where the same EDS is assigned with TTL/HTL encoder, ensure that the identical parameterization is used (e.g. p5300[0] = -1 and p5300[1] = -1, etc.).

NOTICE

Material damage as a result of an unstable controller when manually changing the controller parameters during autotuning

If you wish to manually change a controller parameter, that the "Online tuning" automatically sets, then this can result in an unstable controller and therefore material damage.

- Therefore, do not change the following parameters during the online tuning:
p1413, p1414 - p1426, p1428, p1429, p1433 - p1435, p1441, p1460 - p1465, p1656 - p1676, p2533 - p2539, p2567.

Activating autotuning

You can configure the activation and deactivation of the autotuning function via parameter p5300.

The following settings are possible:

Setting	Explanation
-1	The "Autotuning" function is set inactive. The setting is automatically corrected to p5300 = 0. The default settings for the speed controller and position controller are also restored.
0	The "Autotuning" function is set inactive. The current setting of all controller parameters are retained as volatile values. The parameters must be saved in the non-volatile memory for permanent storage of the values determined for the speed controller and position controller (p0977 = 1).
1	The "One button tuning" function is active. A new calculation of the controller parameters is performed once. p5300 = 0 is then set.
2	The "Online tuning" function is active. A new calculation of the controller parameters is performed cyclically if the estimated moment of inertia changes.

Note

Changing parameter p5300 changes parameters p5280 and p1400. Therefore after deactivating the autotuning function check the accuracy of the configuration of parameters p5280 and p1400 and amend these if required.

Configuring the online tuning

Sequence:

1. Activate the online tuning via p5300 = 2.
2. Configure the sequence control via parameter p5302.
3. Configure the controllers via parameter p5271.

Note

Saving

The parameters must be saved in the non-volatile memory for permanent storage of the values determined for the speed controller and position controller (RAM to ROM or p0977 = 1).

In this way, the start values for the online tuning are retained, e.g. after POWER ON.

Note

Function and supplementary conditions for the inertia estimator

Note the information in Section Inertia estimator (Page 548).

Note

Resetting the inertia estimator

Through deactivation and renewed activation of the online tuning, the estimated load moment of inertia and the load torques are reset.

Setting the sequence control:

The following sequence control settings can be made via p5302:

Bit	Effect
00	The speed controller gain is determined and set with the aid of a noise signal. "Function is being prepared"
01	Any required current setpoint filters are determined and set with the aid of a noise signal. In this way, a higher dynamic response can be achieved in the speed control loop. "Function is being prepared"
02	With this bit, the moment of inertia is determined with the aid of the inertia estimator. If this bit is not set, the load moment of inertia must be parameterized manually in parameter p1498. The test signal must first be set with parameters p5308 and p5309.
03	<ul style="list-style-type: none"> If "Once" is parameterized, the inertia estimator is deactivated after successful determination of the moment of inertia p1498. The parameters must then be saved retentively (p0977=1). If "Cyclically" is parameterized, the moment of inertia is determined continuously and the controller parameters adapted. After the moment of inertia has been determined successfully ($r1407.26 = 1$), it is recommended that you save the parameters so that the controller does not have to resettle after a POWER ON.
06	The function Current setpoint filter adaptation (Page 120) is enabled once this bit is activated. This function can be useful for damping a variable resonance in the mechanical system.
07	With this function, these axes are adapted to the dynamic response set in p5275. This is required for interpolating axes. The time in p5275 should be set with the lowest dynamic response in accordance with the axis.

Parameterizing the controller

You can parameterize the controller as follows via parameter p5271:

- Evaluate the estimated load for the speed controller gain with p5273.
- Activate the speed precontrol for the basic positioner (EPOS).
- Activate the torque precontrol for the basic positioner (EPOS).
- Only with activated speed precontrol (bit 3) or torque precontrol (bit 4): Use the controller as PD controller in the position control loop to increase the dynamic response of the position controller.
- Determine the maximum acceleration limits for the basic positioner (EPOS).
- Do not change the Kp (speed controller gain).

Additional settings and displays

- Set the dynamic response factor (p5272) for the entire P gain of the speed controller.
- Set the estimated load moment of inertia component for the P gain of the speed controller with the load dynamic response factor (p5273).
- Display the estimated dynamic response (r5274) of the speed control loop as PT1 time constant.
- Set the same time constants for the dynamic response time constant (p5275) so that the interpolating drives receive a defined dynamic response via the precontrol. However, this does not always ensure positioning without overshoot.

4.7.2.2 Automatic pre-assignment and adaptation during operation

Automatic pre-assignment

When the "Online tuning" function is activated, settings are made that ensure the safe operation of the online tuning.

Current setpoint filter

The natural frequency of the first PT2 filter behaves proportional to the current controller and speed controller cycles. The faster the sampling, the higher the positive feedback frequency and therefore the higher the frequency must be set for the current setpoint filter.

A lower dynamic response via p5272 makes the control loop less sensitive to resonance from the drive train.

A higher dynamic response via p5272 makes the control loop more sensitive to resonance from the drive train.

The instability of the control loop through resonance can also be avoided through the parameterization of additional bandstop filters in the current setpoint.

Actual speed value filter

An actual speed value filter is required, for example, when the resolution of the encoder is relatively poor. Depending on the encoder resolution and the motor moment of inertia, an actual speed value filter (p1441) is calculated. The time constant of the actual speed value filter is taken into account in the calculation of the controller parameters.

Adaptive resonance filter

The limit frequencies for the adaptive resonance filter are pre-assigned according to the set sampling time. These can be changed manually.

Adapted controller parameters

As soon as the "Online tuning" is active, the controller parameters are adapted to the estimated moment of inertia. However, the controller parameters are only recalculated when the moment of inertia has changed more than 5% compared to the last calculation. Otherwise the controller settings are not changed.

All adaptive controller settings also depend on the moment of inertia, e.g. determined by the estimator. If $p5271.2 = 1$ is set, the K_p factor depends directly on this moment of inertia.

All other variables are only indirectly dependent on the moment of inertia.

K_p (speed controller gain)

The speed controller gain is set proportional to the motor moment of inertia. The gains are proportional to the dynamic response factor $p5272$. An adaptation of the K_p factor depending on the estimated moment of inertia is only performed when $p5271.2$ is set.

Parameter $p5273$ is used to set how many percent of the estimated load moment of inertia is to be taken into account as effective moment of inertia for the calculation of the K_p factor. With 0%, only the motor moment of inertia is effective, with 100%, the total moment of inertia is used for the calculation of the K_p factor.

When calculating the speed controller gain, the time constants of the parameterized current setpoint or actual speed value filter are also taken into account.

T_n (integral time, speed controller)

The integral time results from the estimated dynamic response of the speed control loop ($r5274$).

Reference model

The reference model adapts the speed setpoint for the integrator input of the speed controller to the dynamic response of the speed controller. This reduces speed overshoots during setpoint changes.

Position controller

Two cases can be selected for the position control via bit $p5271.0$.

- $p5271.0 = 0$ (not active)

In this case, the position controller acts like a normal closed-loop P controller. The position controller gain (servo gain factor) is adapted depending on the estimated dynamic response of the speed control loop and the sample times.

- $p5271.0 = 1$ (active)

If this bit is set and the estimated dynamic response ($r5274$) is greater than 16 ms, then the first speed setpoint filter is parameterized as D filter. With the parameterization, the gain for higher frequencies is greater and the filter has a more differentiated effect in the bandwidth of the speed controller (larger phase reserve). This corresponds to a PD controller. The servo gain factor may then be increased significantly.

The precontrol balancing is also adapted.

The balancing of the speed controller precontrol depends on parameters $p5271$ and $p5275$.

Determining the maximum acceleration limits

Prerequisite is that the pulses have been disabled in the drive and the maximum moment of inertia has been determined.

The maximum target acceleration for the basic positioner (EPOS) is determined with the aid of the inertia estimator. This is performed only once after the activation of bit p5271.5. The load torques and a control reserve of 20% are taken into account.

The user must decide to what extent this maximum acceleration is permissible for the mechanical system of the machine (elastomechanical system) or for the thermal load capability of the motor (depending on the load cycle). The calculated acceleration (p2572) or deceleration (p2573) may have to be reduced by the commissioning engineer.

4.7.2.3 Application examples

Positioning axes

A positioning axis application can always be used when an axis performs a point-to-point motion independent of other axes. p5302.7 = 0 must be set.

The axis is tuned for positioning without overshoot.

Interpolating axes

EPOS position controller with higher-level controller

Interpolating axis applications are required when several axes jointly perform a path motion, for example, in which the deviation to the contour should be as small as possible. Parameter p5302.7 = 1 must be set. The precontrol must not be switched off subsequently.

The controlled dynamic response is set with parameter p5275. All interpolating axes must have the same value.

With values that are too small, the axis can overshoot during positioning. If this has a negative effect on the application, the value in p5275 must be increased in all axes. The axis with the largest estimated time constant (r5274) in the settled state is the determining axis.

4.7.2.4 Problem handling

Drive vibrates

If the drive vibrates audibly, then the speed controller may have become unstable at a mechanical resonance.

Remedy:

- The instability in the control loop through resonance can be avoided by parameterizing bandstop filters in the current setpoint.
- Activate the adaptive resonance filter (see Section "Current setpoint filter adaptation (Page 120)") and, if required, traverse forward and backward and wait a few seconds to see whether the oscillation stops. If the whistling stops and also can no longer be heard during operation, then the axis is ready.
- If required, the dynamic response of the axis can now be increased. To do this, the value of parameter p5272 can be increased. If the drive then vibrates again, parameter p5272 should be reduced again.

Behavior at low speeds

If the drive has an encoder with poor resolution, the motor may hum at very low speeds or at standstill.

Remedy:

- Increase the actual speed value smoothing (p1441) or reduce the dynamic response (p5272).
- Set parameter p5271.1 to reduce the controller gains for low speeds.

Poor positioning behavior

Poor positioning behavior is possible when the dynamic response of the drive is relatively low.

The achievable dynamic response depends on the quality and the dimensioning of the elastomechanical drive train.

Remedy:

Increase the value of parameter p5272 in order to increase the dynamic response of the drive. The drive may become unstable if the values are too high (see, for example, "Drive vibrates").

4.7.3 Current setpoint filter adaptation

4.7.3.1 Activating/deactivating the current setpoint filter adaptation

The "Current setpoint filter adaptation" function is used to automatically shift a selected current setpoint filter to a mechanical resonance frequency.

The function is particularly recommended for systems that display a variable mechanical resonance frequency during operation. If this system also contains non-variable mechanical resonance frequencies, they must be suppressed via fixed current setpoint filters.

If the system only contains non-variable mechanical resonance frequencies, they must be suppressed exclusively with fixed current setpoint filters. Instead of the current setpoint filter adaptation, use the "One button tuning" (Page 109) for this.

Note

The "Current setpoint filter adaptation" function is activated for S120 drives together with the "Moment of inertia estimator (Page 548)" function module.

Settings of the adaptive current setpoint filter

You can configure the activation and deactivation of the current setpoint filter adaptation via parameter p5280.

The following settings are possible:

Setting	Explanation
-1	The "Current setpoint filter adaptation" function is deactivated together with the assigned filter (see p5281). With this setting, not only the adaptation, but also an assigned filter is deactivated. The associated bit is automatically deleted in parameters p1656 and p5200. However, the filter is not reset in its characteristic, it retains the values saved last. In contrast, the adaptation parameter is automatically reset to 0.
0	The "Current setpoint filter adaptation" function is inactive. The adaptation is deactivate with this setting. However, a filter assigned to the adaptation can still be active. The filter function is not affected by this setting.
1	The "Current setpoint filter adaptation" function is permanently active. A mechanical resonance frequency is determined with this activation and the appropriate blocking frequency is set automatically. If the bandstop filter has not been activated yet (see parameter p1656 or p5200), it is activated automatically. While the function generator generates a signal with the "noise" signal shape (p4820 = 4), the adaptation is temporarily inactive.

Further parameters of the current setpoint filter adaptation and their purpose:

- p5281 = specifies which of the current setpoint filters is to be used for the adaptation
- p5282 = defines the lower limit frequency
- p5283 = defines the upper limit frequency
- p5284 = defines the activation threshold of the adaptation
- r5285 = displays the current blocking frequency

Note

Deviation with activated online tuning (p5300 = 2)

The denominator damping of the adapted filter is set automatically.

You can also overwrite this setting.

Activating the current setpoint filter adaptation

Note

Current setpoint filters 1 ... 4 are standard. The extended current setpoint filters 5 ... 10 can be activated additionally (see Chapter "Extended current setpoint filters (Page 96)").

Several settings still have to be made or checked before activating the adaptation.

1. Parameterize the desired current setpoint filter as bandstop filter.
2. Assign the desired current setpoint filter to the adaptation via parameter p5281 (example of filter 4: p5821 = 4).
3. Activate the adaptation via the setting p5280 = 1.

Note

If not all the requirements were satisfied before the adaptation was activated, fault F07419 "Drive: Current setpoint filter adaptation error" is output. The fault value indicates which requirement has not been satisfied.

Deactivating the adaptation

The current setpoint filter adaptation can be deactivated in two ways:

1. Deactivate the adaptation. Set the following values:
 - p5280 = 0 or
 - p5280 = -1

4.7.3.2 Principle of operation of the current setpoint filter adaptation

- As soon as the pulse enable has been set and a resonance frequency has been excited enough that the internal activation threshold is exceeded, the adaptation moves the bandstop filter to this resonance frequency.
- If the resonance frequency has not been excited enough or there is no interfering resonance frequency, the bandstop filter stops and the current blocking frequency does not change.

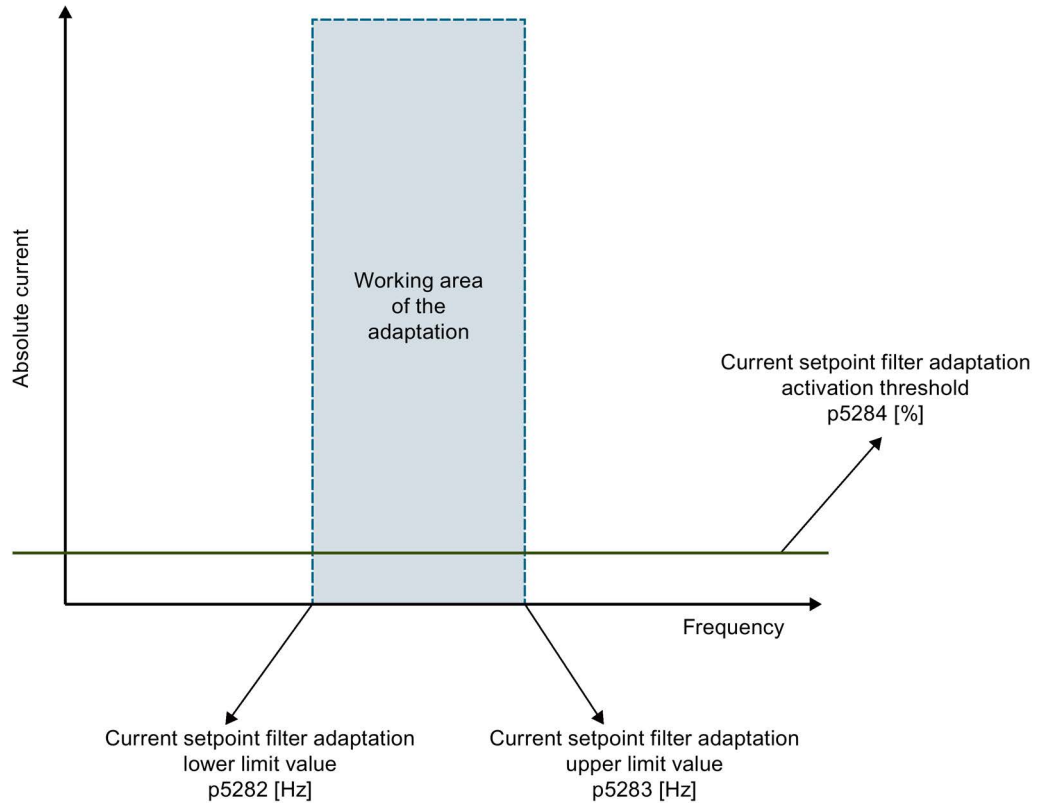

Figure 4-11 Principle of operation

- The calculated values for the numerator and denominator damping of the bandstop filter are tracked during the movement so that the bandwidth of the bandstop filter increases with increasing blocking frequency.
- The current frequency of the bandstop filter can be read and recorded via r5285. This frequency is also written to the appropriate frequency parameters of the adapted current setpoint filter.

Limitations:

- Because of the operating principle, the base adaptation algorithm can work reliably with systems that have only one mechanical resonance frequency. Undesirable movements of the adapted filter between the resonances can occur for systems with several mechanical resonance frequencies.
- Because of the operating principle, inaccuracies can occur during the adaptation of the blocking frequency. In such cases, the resonance frequency is only partly suppressed. This is particularly the case for encoders with poor resolution (e.g. resolvers). These inaccuracies can be reduced by increasing the actual speed value smoothing time constant in parameter p1441.
- Stepped setpoint changes of the speed or velocity can cause unwanted movements of the adaptive current setpoint filter.
- If in addition to a variable mechanical resonance frequency, the system also contains non-variable mechanical resonance frequencies, the non-variable frequencies must be suppressed with fixed current setpoint filters. The adapted bandstop filter should be the last filter in the filter cascade of the bandstop filters. Otherwise the adaptation may be subject to interference from non-variable resonance frequencies, which may cause unwanted movements of the blocking frequency.

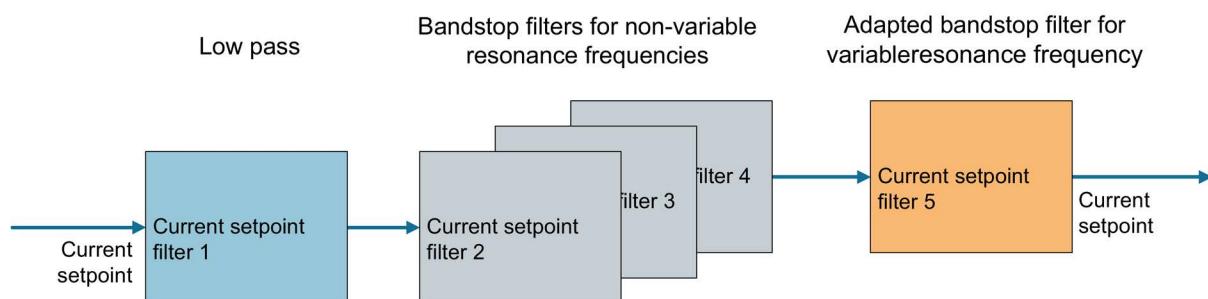

Figure 4-12 Example: Current setpoint filter 5 is the last filter used in the cascade

Internal activation threshold

The internal activation threshold can be weighted via parameter p5284:

- If the adaptation reacts too sensitively to other disturbances such as jumps in the speed or load torque, the activation threshold should be set high.
- If the adaptation is too insensitive and resonance frequencies do not occur despite strong excitation, the activation threshold can be reduced.

Range of movement of the adapted filter

The range of movement of the adapted filter can be limited with parameter p5282 or p5283.

Start value of the adaptation

The frequency with which the adaptation starts at the pulse enable, i.e. the start value of the adaptation, is always the current blocking frequency of the filter. It can be read in r5285 and in the filter frequency parameters. After a pulse inhibit and renewed pulse enable, this starting frequency is the blocking frequency last determined before the pulses were inhibited. After switching the drive off and on, the adaptation starts with the frequency stored in the frequency parameters of the adapted filter.

You have the following options in order to find a suitable start value for the frequency of the adaptation:

- Use the current position of the resonance frequency as start value.
 - To do this, read the current resonance frequency from the frequency response measurement or
 - Determine the current resonance frequency from one cycle of the "One button tuning".
- OR
- Use 500 Hz as start value.

The start value may be above or below the sought resonance frequency. This value should be set as blocking frequency of the respective bandstop filter before the adaptation is activated and the pulse enable set.

4.7.3.3 Stability of the speed control loop

Moving the bandstop filter changes the phase and amplitude frequency response of the speed control loop. The stability of the speed control loop is not checked by the current setpoint filter adaptation. If the current setpoint filter adaptation is operated with activated online tuning (p5300 = 2), parameter settings are made automatically that guarantee the stability.

If the autotuning is not activated, you have to make settings yourself that prevent an instability. You must ensure a sufficiently large phase reserve. Note the following points:

- The phase and amplitude frequency response of the adapted filter
- The lower limit frequency of the adaptation (p5282)

A resonance frequency can be moved by the active closed-loop control. An instability of the controller can be provoked by too high a controller gain that has a higher amplitude than the mechanical resonance frequency and therefore influences the adaptation.

4.7.3.4 Lower and upper limit frequencies

Parameter p5283 for the upper limit frequency has an internal upper limit that depends on the settings for the adapted current setpoint filter. It is only active with an active adaptation.

- If the adaptation is active, p5283 is limited immediately to this internal value when written.
- If the adaptation is not active, p5283 is automatically limited to the internal value when the adaptation is activated.

For the case that one of the limit frequency parameters (p5282 or p5283) is written and the current blocking frequency of the bandstop filter is beyond the relevant new limit frequency, the following applies:

- If the adaptation is active, the bandstop filter is automatically set to the relevant limit frequency when p5282 or p5283 is written.
- If the adaptation is not active, the bandstop filter is automatically set to the relevant limit frequency when the adaptation is activated.

4.7.3.5 Remedy for insufficient adaptation

Generally, the following is valid: If the adaptation does not change the blocking frequency of the adapted current setpoint filter during operation, then the resonance is obviously not strong enough and therefore has no negative effect on the operation.

If you still want to change the behavior of the adaptation, you have the following options:

- Change the activation threshold (p5284).
- Change the blocking frequency in the relevant filter parameters in order to obtain a different start value for the adaptation.
- Increase the speed controller gain via p1460 or p5272. This excites the mechanical resonance frequency more strongly, to which the adaptation then reacts. However, observe the stability of the control loop with this setting.

4.7.4 Function diagrams and parameters

Overview of important faults (see SINAMICS S120/S150 List Manual)

- F07419 Drive: Incorrect current setpoint filter adaptation

Overview of important parameters (see SINAMICS S120/S150 List Manual)

- p0108[0...n] Drive object function module
- p1400[0...n] Speed control configuration
- p5271[0...n] "Online tuning" configuration
- p5272[0...n] Online tuning dynamic response factor
- p5273[0...n] Online tuning load dynamic response factor
- r5274[0...n] CO: Online tuning estimated dynamic response
- p5275[0...n] Online tuning dynamic response time constant
- p5280[0...n] Current setpoint filter adaptation configuration
- p5281[0...n] Current setpoint filter adaptation assignment
- p5282[0...n] Current setpoint filter adaptation lower limit frequency
- p5283[0...n] Current setpoint filter adaptation upper limit frequency
- p5284[0...n] Current setpoint filter adaptation activation threshold
- r5285[0...n] Current setpoint filter adaptation current frequency
- p5292 FFT tuning dynamic response factor
- r5293 FFT tuning speed controller P gain identified
- r5294[0...3] FFT tuning zero position identified
- r5295[0...3] FFT tuning pole position identified
- p5296 FFT tuning PRBS amplitude
- p5297 FFT tuning PRBS offset
- p5300[0...n] Autotuning selection
- p5301[0...n] "One button tuning" configuration
- p5302[0...n] "Online tuning" configuration
- p5308[0...n] Test signal distance limit
- p5309[0...n] Test signal duration

4.8 Note about the electronic motor model

A model change takes place within the speed range $p1752 \times (100\% - p1756)$ and $p1752$. With induction motors with encoder, the torque image is more accurate in higher speed ranges; the effect of the rotor resistance and the saturation of the main field inductance are corrected. With synchronous motors with encoder, the commutation angle is monitored. If the kT estimator has been activated, the torque image for synchronous motors is more accurate too.

4.9 V/f control

For V/f control, the drive is operated with an open control loop. In this open-loop control system, the drive does not require speed feedback and no actual current sensing. Operation is possible with a small amount of motor data.

With V/f control, the following components and data can be checked:

- Motor Module
- Power cable between the Motor Module and motor
- Motor
- DRIVE-CLiQ cable between the Motor Module and motor
- Encoder and actual encoder value

The following motors can be operated with V/f control:

- Induction motors
- Synchronous motors

Note

In the U/f mode, the calculated actual speed value is always displayed in r0063. The speed of the encoder (if installed) is displayed in r0061. If an encoder is not installed, r0061 displays "0".

Note

The operation of synchronous motors with V/f control is allowed only at up to 25% of the rated motor speed.

Note

Restricted applications for U/f control

U/f control must only be used as a diagnostic function (e.g. to check that the motor encoder is functioning correctly).

The activated U/f control blocks all other settings, for example current controller or speed controller.

Structure of V/f control

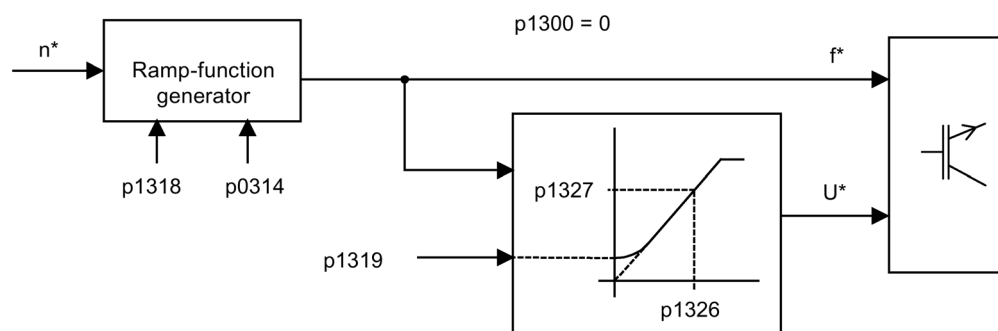

Figure 4-13 Structure of V/f control

Commissioning U/f control

Note

With synchronous motors, U/f mode is normally only stable at low speeds. Higher speeds can induce oscillations.

Oscillation damping is activated on the basis of suitable default parameter values and does not require further parameterization in most applications. If you become aware of interference caused by a transient response, you have the option of gradually increasing the value of $p1338$ in small steps and evaluating how this affects your system.

Note

The drive can be ramped up to the current limit ($p0640$) relatively quickly without the need for extensive parameterization (when operating the drive with a variable moment of inertia, for example).

Note the following: Only the ramp-function generator stops when the current limit ($p0640$) is reached. This does not prevent the current from increasing even further. In view of this, the parameters you assign must include a safety margin relative to the current limits for the monitoring functions to prevent the drive from switching off with an overcurrent fault.

1. Check the requirements for U/f control.
 - First commissioning has been carried out:
The parameters for V/f control have been initialized with appropriate values.
 - First commissioning has not been carried out:
The following relevant motor data must be checked and corrected:
 - r0313 Motor pole pair number, actual (or calculated)
 - p0314 Motor pole pair number
 - p1318 V/f control ramp-up/ramp-down time
 - p1319 V/f control voltage at zero frequency
 - p1326 V/f control programmable characteristic frequency 4
 - p1327 V/f control programmable characteristic voltage 4
 - p1338[0...n] V/f mode resonance damping gain
 - p1339[0...n] V/f mode resonance damping filter time constant
 - p1349[0...n] V/f mode resonance damping maximum frequency
2. Set the rated motor speed via parameter p0311.
3. Activate U/f control with the parameter setting of p1317 = 1.

Note

Automatic activation of additional functions

With p1317 = 1, the following functions are also activated automatically:

- Resonance damping (p1338)
In order to obtain a pure diagnostic mode without any influence on actual values, the resonance damping must be deactivated (p1338 = 0)
 - Vdc controller (p1240, p1244, p1248, p1250)
 - Limitation of the up ramp as a result of M, P and I limits
 - The ramp-function generator is stopped as soon as the current limit p0640 is exceeded.
-

4. Issue the enable signals for operation.
5. Enter the speed setpoint.

V/f characteristic

The speed setpoint is converted to the frequency specification taking into account the number of pole pairs. The synchronous frequency associated with the speed setpoint is output (no slip compensation).

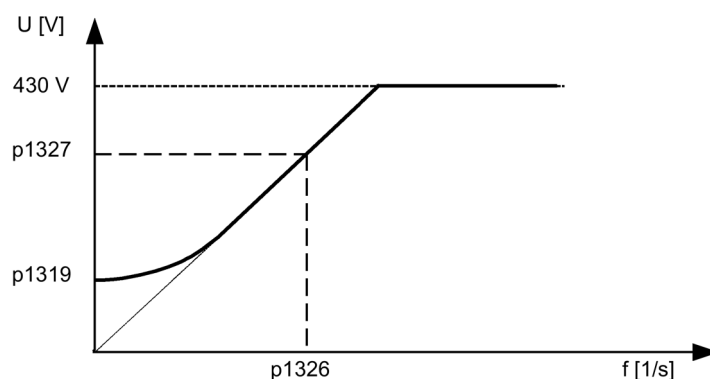

Figure 4-14 V/f characteristic

Function diagrams (see SINAMICS S120/S150 List Manual)

- 5300 Servo control - V/f control for diagnostics
- 5650 Servo control - Vdc_max controller and Vdc_min controller

Overview of important parameters (see SINAMICS S120/S150 List Manual)

- p0304[0...n] Rated motor voltage
- p0310[0...n] Rated motor frequency
- p0311[0...n] Rated motor speed
- r0313[0...n] Motor pole pair number, current (or calculated)
- p0314[0...n] Motor pole pair number
- p0317[0...n] Motor voltage constant
- p0322[0...n] Maximum motor speed
- p0323[0...n] Maximum motor current
- p0640[0...n] Current limit
- p1082[0...n] Maximum speed
- p1317[0...n] V/f control activation
- p1318[0...n] V/f control ramp-up/ramp-down time
- p1319[0...n] V/f control voltage at zero frequency
- p1326[0...n] V/f control programmable characteristic frequency 4
- p1327[0...n] V/f control programmable characteristic voltage 4

4.10 Optimizing the current and speed controller

Note

Controller tuning may only be performed by skilled personnel with a knowledge of control engineering.

The following tools are available for tuning the controllers:

- Function generator in STARTER
- Trace in STARTER
- Measuring function in STARTER
- Measuring sockets on the Control Unit

Tuning the current controller

The current controller is initialized when the system is commissioned for the first time and is adequately tuned for most applications.

Tuning the speed controller

The speed controller is set in accordance with the motor moment of inertia when the motor is configured for the first time. The calculated proportional gain is set to approximately 30% of the maximum possible gain in order to minimize vibrations when the controller is mounted on the mechanical system of the machine for the first time.

The integral time of the speed controller is always preset to 10 ms.

The following tuning measures are necessary in order to achieve the full dynamic response:

- Increase the proportional gain $K_{p,n}$ (p1460)
- Change the integral time $T_{n,n}$ (p1462)

Automatic controller setting of the speed controller (frequency response analysis) in STARTER

- The automatic speed controller setting has the following features:
 - Section identification using FFT analysis
 - Automatic setting of filters in the current setpoint arm, e.g. for damping resonance
 - Automatic setting of the controller (gain factor K_p , integral time T_n)
- The automatic controller settings can be verified with the measuring functions.

The "Automatic Controller Setting" parameter screen is selected with the  icon in the toolbar of the STARTER commissioning tool.

Example of measuring the speed controller frequency response

By measuring the speed controller frequency response and the control system, critical resonance frequencies can, if necessary, be determined at the stability limit of the speed control loop and dampened using one or more current setpoint filters. This normally enables the proportional gain to be increased (e.g. $K_{p_n} = 3 \times$ default value).

After the K_{p_n} value has been set, the ideal integral time T_{n_n} (e.g. reduced from 10 ms to 5 ms) can be determined.

Example of speed setpoint step change

A rectangular step change can be applied to the speed setpoint via the speed setpoint step change measuring function. The measuring function has preselected the measurement for the speed setpoint and the torque-generating current.

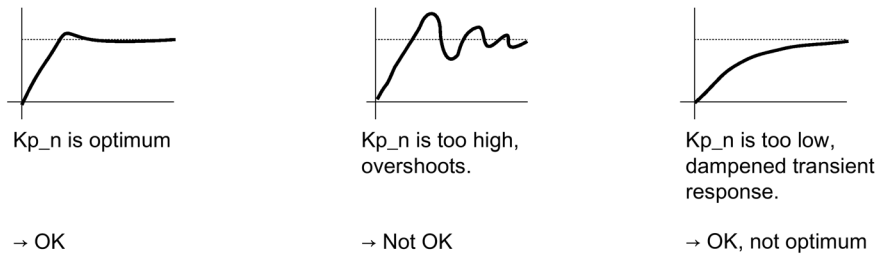

Figure 4-15 Setting the proportional gain K_p

4.11 Encoderless operation

Note

Unstable operation

The operation of synchronous motors without an encoder must be verified in a test application. Stable operation in this mode cannot be guaranteed for every application. Therefore, the user will be solely responsible for the use of this operating mode.

Description

Both encoderless and mixed operation (with/without encoder) is possible. Encoderless operation with the motor model allows a higher dynamic response and greater stability than a standard drive with V/f control. Compared with drives with an encoder, however, speed accuracy is lower and the dynamic response and smooth running features deteriorate.

Since the dynamic response in operation without an encoder is lower than in operation with an encoder, acceleration torque precontrol is implemented to improve the control dynamic performance. It controls, knowing the drive torque, and taking into account the existing torque and current limits as well as the load moment of inertia (motor moment of inertia: $p0341 \times p0342 + \text{load torque: } p1498$), the required torque for a demanded speed dynamic performance optimized from a time perspective.

Note

If the motor is operated with and without an encoder (e.g. $p0491 \neq 0$ or $p1404 < p1082$), the maximum current during operation without an encoder can be reduced via $p0642$ (reference value is $p0640$) in order to minimize interfering, saturation-related motor data changes during operation without an encoder.

A torque smoothing time can be parameterized via $p1517$ for the torque precontrol. The speed controller needs to be optimized for operation without an encoder due to the lower dynamic response. This can be achieved via $p1470$ (P gain) and $p1472$ (integral time).

In the low-speed range, the actual speed value, the orientation, and the actual flux can no longer be calculated during operation without an encoder due to the accuracy of the measured values and the parameter sensitivity of the procedure. This is the reason that the system switches over to current/frequency control (I/f-controlled operation), where only the current and frequency are impressed. The switchover threshold is parameterized via $p1755$ and the hysteresis via $p1756$.

To accept a high load torque even in the open-loop controlled range, the motor current (current setpoint) can be set using $p1612$. To do so, the drive torque (e.g. friction torque) must be known or estimated. An additional reserve of approx. 20% should also be added. In synchronous motors, the torque is converted to the current via the motor torque constant ($p0316$). For induction motors, the magnetizing current ($r0331$) must be additionally taken into account in $p1612$. In the lower speed range, the required current cannot be measured directly on the Motor Module. The default setting is 50% (synchronous motor) or 80% (induction motor) of the motor rated current ($p0305$). When parameterizing the motor current

(p1612), you must take into account the thermal motor load, as the current entered in p1612 is impressed in I/f-controlled operation also without load.

Note

Encoderless operation is not permitted for vertical axes or similar. Encoderless operation is not suitable for a higher-level closed-loop position control either.

The starting behavior of synchronous motors from standstill can be improved further by parameterizing the pole position identification (p1982 = 1).

Behavior once pulses have been canceled

Once the pulses have been canceled in operation without an encoder, the current actual speed value of the motor can no longer be calculated. Once the pulses are enabled again, the system must search for the actual speed value.

p1400.11 can be used to parameterize whether the search is to begin with the speed setpoint (p1400.11 = 1) or with speed = 0.0 (p1400.11 = 0). Under normal circumstances, p1400.11 = 0 because the motor is usually started from standstill. If the motor is rotating faster than the changeover speed p1755 when the pulses are enabled, p1400.11 = 1 must be set.

If the motor is rotating and the start value for the search is as of the setpoint (p1400.11 = 1), the speed setpoint must be in the same direction as the actual speed before the pulses can be enabled. A large discrepancy between the actual and setpoint speed can cause a malfunction.

	<p>CAUTION</p>
<p>Risk of injury by evaluating incorrect motor speed information</p> <p>Once the pulses have been canceled, no information about the motor speed is available. The drive sets its speed actual value = "0" Messages and signals derived from the actual value no longer provide any information. Evaluating these messages and signals can result in the risk of injury and material damage.</p> <ul style="list-style-type: none"> • Take this behavior into consideration when engineering your plant or system. 	

Switchover between closed-loop/open-loop operation and operation with/without encoder

Operation without an encoder is activated using parameter setting p1300 = 20. If p1300 = 20 or p1404 = 0, operation without an encoder is active across the entire speed range. If the speed value is less than the changeover speed p1755, the motor is operated in accordance with the current/frequency.

During operation with an encoder, a switchover can be made to operation without an encoder when the speed threshold p1404 is exceeded. If p1404 > 0 and p1404 < p1755, a switchover is not made to operation without an encoder until the speed exceeds p1755.

To prevent encoder evaluation alarms in encoderless operation, set p1402.1 = 1 to park the encoder evaluation. Reading-in the motor temperature via the encoder evaluation remains active.

Operation without an encoder is displayed in parameter r1407.1.

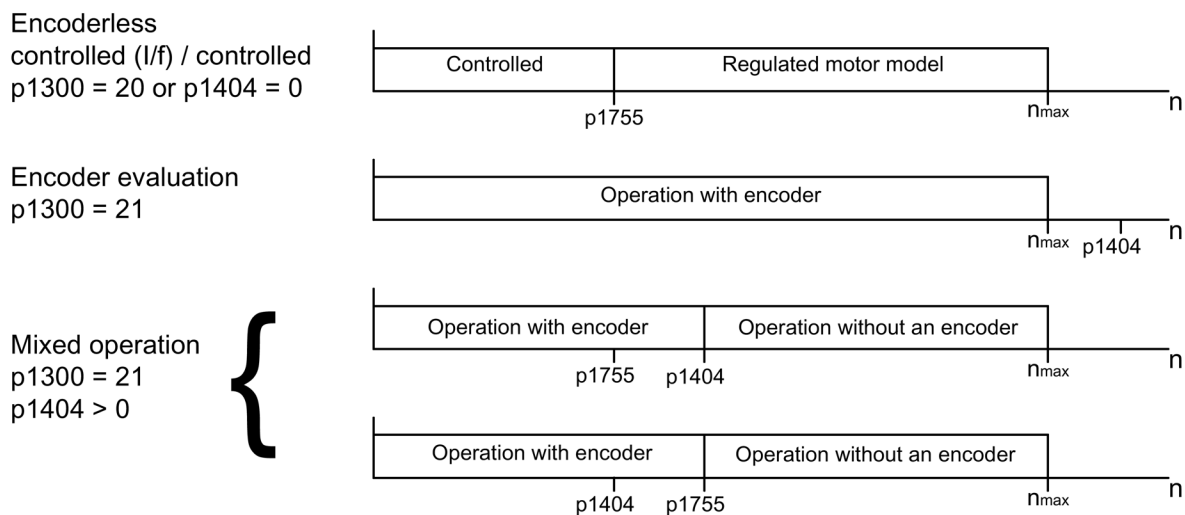

Figure 4-16 Area switchover

Note

In closed-loop control operating mode "Speed controller without encoder", a rotor position encoder is not required. Temperature evaluation remains active, even when the encoder is parked. This state can be identified at parameter r0458.26 = 1. When parameter r0458.26 = 0, temperature sensing is also deactivated.

Series reactor

When high-speed special motors are used, or other low leakage induction motors, a series reactor may be required to ensure stable operation of the current controller.

The series reactor can be integrated via p0353.

Commissioning/optimization

1. Estimate the motor current p1612 on the basis of the mechanical conditions ($I = M/kt$).
2. For synchronous motors with high overload setting (p0640 significantly higher than p0305), it may be necessary to reduce the current limiting in encoderless operation (p0642).
3. For a third-party motor, carry out the stationary measurement - and if possible - also the rotating measurement and accept the determined data (see Chapter "Motor data identification (Page 141)"). Check the current controller setting.
4. If the total moment of inertia has not already been determined using the rotating measurement, you have the possibility of determining the total moment of inertia as follows:
 - If an encoder is being used, and the motor has a restricted traversing path (e.g. encoderless operation is only used when an encoder develops a fault or only for the upper speed range):

Determine the moment of inertia using the rotating measurement of the motor data identification (p1959 = 420 hex (i.e. only commutation angle and Lq characteristic), p1960 = 1). If you carry out the motor data identification using the STARTER screen, set p1959, start the measurement and accept the result.
 - If the motor can endlessly rotate (with and without encoder)

Determine the moment of inertia using the rotating measurement of the motor data identification (p1959 = 404 hex (i.e. only commutation angle and moment of inertia), p1960 = 1). If you carry out the motor data identification using the STARTER screen, set p1959, start the measurement and accept the result.
 - You can also determine the moment of inertia using the "Moment of inertia estimator" function module (see Chapter "Moment of inertia estimator (Page 548)"). As the moment of inertia is also determined in operation using this function module, we recommend that the "Moment of inertia estimator" function module is used if the total moment of inertia changes during operation.

5. Set the speed controller:

- When the "Moment of inertia estimator" function module is active, accept the moment of inertia that has been determined.
- Deactivate the "Moment of inertia estimator" function module ($p1400.18 = 0$).
- Start a trace recording of parameter r0063 (speed actual value) and r0079 (torque).
- Adjust the moment of inertia ($p1498$; if possible, increase), and in the controlled range, enter a speed setpoint (speed higher than $p1755$).
- Optimize the settling behavior using the P gain ($p1470$) and the integral time ($p1472$).

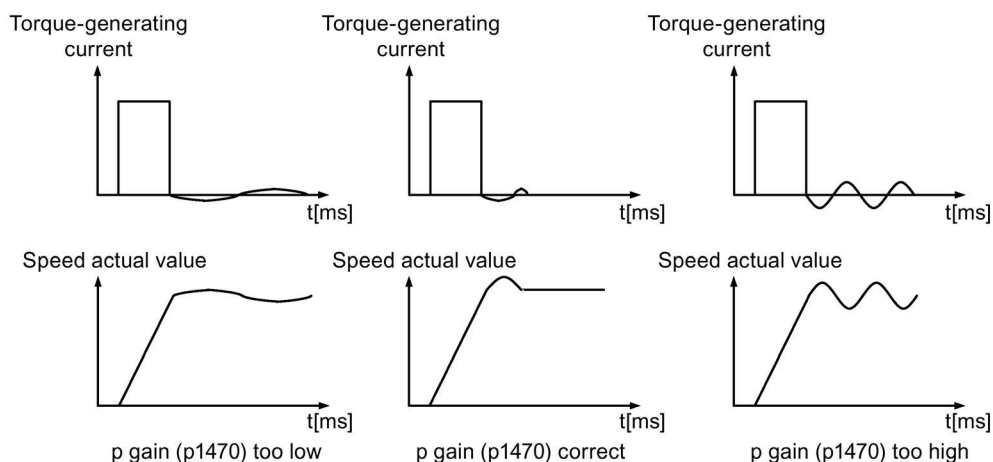

- Exit the trace recording.
- Finally, again set the appropriate total moment of inertia - or activate the "Moment of inertia estimator" function module

Function diagrams (see SINAMICS S120/S150 List Manual)

- 5019 Servo control - Speed control and V/f control, overview
- 5050 Servo control - Speed controller adaptation (Kp_n/Tn_n adaptation)
- 5060 Servo control - Torque setpoint, switchover control mode
- 5210 Servo control - Speed controller without encoder

Overview of important parameters (see SINAMICS S120/S150 List Manual)

- p0341[0...n] Motor moment of inertia
 - p0342[0...n] Ratio between the total and motor moment of inertia
 - p0353[0...n] Motor series inductance
 - p0600[0...n] Motor temperature sensor for monitoring
 - p0640[0...n] Current limit
 - p0642[0...n] Encoderless operation current reduction
 - p1300[0...n] Open-loop/closed-loop control operating mode
 - p1400[0...n] Speed control configuration
 - p1404[0...n] Encoderless operation changeover speed
 - r1407.0...26 CO/BO: Status word, speed controller
 - p1470[0...n] Speed controller encoderless operation P gain
 - p1472[0...n] Speed controller sensorless operation integral time
 - p1498[0...n] Load moment of inertia
 - p1517[0...n] Acceleration torque smoothing time constant
 - p1612[0...n] Current setpoint, open-loop control, encoderless
 - p1755[0...n] Motor model changeover speed encoderless operation
 - p1756 Motor model changeover speed hysteresis
- "Moment of inertia estimator" function module**
- p0108[0...n] Drive object function module
 - p1400[0...n] Speed control configuration

4.12 Motor data identification

Description

The motor data identification (MotID) is used as a tool to determine the motor data, e.g. of third-party motors and can help to improve the torque accuracy (k_T estimator). The drive system must have been commissioned for the first time as basis for using motor data identification. To do this, either the electrical motor data (motor data sheet) or the rating plate data must be entered and the calculation of the motor/control parameters (p0340) must have been completed.

Commissioning involves the following steps:

1. Enter the motor data or the rating plate data and the encoder data.
2. Complete calculation of the motor and control data as starting value for the motor data identification (p0340 = 3, if motor data, p0340 = 1, if rating plate data was entered).
3. Carry out a static measurement (p1910).
4. For synchronous motors: Carry out a commutation angle calibration (p1990) and if required, fine synchronization by passing the zero mark (refer to r1992). Absolute encoders do not have to be finely synchronized. For fine synchronization, also refer to Section "Pole position identification (Page 156)" under "Pole position correction with zero marks".
5. Carry out a rotating measurement (p1960).

Before starting the rotating measurement, the speed controller setting should be checked and tuned (p1460, p1462 and p1470, p1472).

It is preferable if the rotating motor data identification is carried out with the motor decoupled from the mechanical system. This therefore means that only the motor moment of inertia is determined. The total moment of inertia with mechanical system can be subsequently identified with p1959 = 4 and p1960 = 1. The stress on the mechanical system can be reduced by parameterizing the ramp-up time (p1958), using direction limiting (p1959.14/p1959.15) or using the current and speed limit. The higher the selected ramp-up time, the less accurate the moment of inertia determined.

6. To store the results of the motor data identification retentively, you must perform the "Copy RAM to ROM" command.

Note

Completion of the individual identification runs can be read via parameters r3925 to r3928.

The enable signals OFF1, OFF2, OFF3 and "enable operation" remain effective and can interrupt the motor data identification routine.

If there is an extended setpoint channel ($r0108.08 = 1$), $p1959.14 = 0$ and $p1959.15 = 0$ and direction limiting ($p1110$ or $p1111$) is active there, then this is observed at the instant of the start via $p1960$. For $p1958 = -1$, the ramp-up and ramp-down time of the setpoint channel ($p1120$ and $p1121$) are also used for the motor data identification.

Note

If a ramp-up/ramp-down time or direction limiting is active, parts of the motor data identification routine cannot be executed. For other parts of the motor data identification routine, the accuracy of the results is diminished because a ramp-up/ramp-down time is selected. If possible, $p1958$ should be 0 and no direction limiting selected ($p1959.14 = 1$ and $p1959.15 = 1$).

Motor movement during the motor data identification

The stationary motor data identification can result in slight movement of up to 210 degrees electrical.

For the rotating motor data identification routine, motor motion is initiated, which can reach the maximum speed ($p1082$) and the motor torque corresponding to the maximum current ($p0640$).

The rotating measurement should be carried out with a motor running at no load (de-coupled from the mechanical system) in order to prevent damage/destruction to the load or be influenced by the load. If the motor cannot be de-coupled from the mechanical system, then the stress on the mechanical system can be reduced by parameterizing the ramp-up time ($p1958$) and/or using direction limiting ($p1959.14/p1959.15$) or using the current and speed limit.

 WARNING
--

Danger to life as a result of motor movement when identifying the motor data

Motor movement caused by the motor data identification routine can result in death, severe injury or material damage.

- | |
|---|
| <ul style="list-style-type: none">• Ensure that nobody is in the hazardous zone - and that the mechanical system can freely move.• Do not carry out the rotating measurement if the traversing distance is mechanically limited. |
|---|

Motor data

Motor data input requires the following parameters:

Table 4- 9 Motor data

Induction motor	Permanent-magnet synchronous motor
<ul style="list-style-type: none"> • p0304 rated motor voltage • p0305 rated motor current • p0307 rated motor power • p0308 rated motor power factor • p0310 rated motor frequency • p0311 rated motor speed • p0320 rated motor magnetizing current • p0322 maximum motor speed • p0350 motor stator resistance, cold • p0353 motor series inductance • p0354 motor rotor resistance, cold • p0356 motor stator leakage inductance • p0358 motor rotor leakage inductance • p0360 motor magnetizing inductance • p0400ff encoder data 	<ul style="list-style-type: none"> • p0305 rated motor current • p0311 rated motor speed • p0314 motor pole pair number • p0316 motor torque constant • p0322 maximum motor speed • p0323 maximum motor current • p0341 motor moment of inertia • p0350 motor stator resistance, cold • p0353 motor series inductance • p0356 motor stator leakage inductance • p0400ff encoder data

Rating plate data

Input of the rating plate data requires the following parameters:

Table 4- 10 Rating plate data

Induction motor	Permanent-magnet synchronous motor
<ul style="list-style-type: none"> • p0304 rated motor voltage • p0305 rated motor current • p0307 rated motor power • p0308 rated motor power factor • p0310 rated motor frequency • p0311 rated motor speed • p0322 maximum motor speed • p0353 motor series inductance • p0400ff encoder data 	<ul style="list-style-type: none"> • p0304 rated motor voltage • p0305 rated motor current • p0307 rated motor power (alternative p0316) • p0311 rated motor speed • p0314 motor pole pair number or p0315 motor pole pair width • p0322 maximum motor speed • p0323 maximum motor current • p0353 motor series inductance • p0400ff encoder data

Since the rating plate data contains the initialization values for identification, you must ensure that it is entered correctly and consistently to enable the above data to be determined.

Parameters to control the motor data identification

The following parameters influence the motor data identification:

Table 4- 11 Parameters for control

Static measurement (motor data identification)	Rotating measurement
<ul style="list-style-type: none"> • p0640 current limit • p1215 motor holding brake configuration • p1909 motor data identification control word • p1910 motor data identification, stationary • p1959.14/.15 positive/negative direction permitted¹⁾ 	<ul style="list-style-type: none"> • p0640 current limit • p1082 maximum speed • p1958 motor data identification ramp-up/ramp-down time • p1959 rotating measurement configuration • p1960 rotating measurement selection

¹⁾ The setting of p1959 has the following effects for the direction of rotation p1821:
 - Positive direction permitted, with setting p1821=0 means: Clockwise direction of rotation
 - Negative direction permitted, with setting p1821=1 means: Counter-clockwise direction of rotation

Note

If a brake is being used and is operational (p1215 = 1, 3), the stationary measurement is made with closed brake. If possible (e.g. no hanging/suspended axis), we recommend that the brake is opened before the motor data identification (p1215 = 2). This also means that the encoder size can be adjusted and the commutation angle calibrated.

4.12.1 Motor data identification induction motor

The data are identified in the inverse gamma equivalent circuit diagram and displayed in r19xx. The motor parameters p0350, p0354, p0356, p0358 and p0360 taken from the motor data identification refer to the T equivalent circuit diagram of the induction machine and cannot be directly compared. This is the reason that an r parameter is listed in the table, which displays the parameterized motor parameters in the inverse gamma equivalent circuit diagram.

Table 4- 12 Data determined using p1910 for induction motors (stationary measurement)

Determined data (gamma)	Data that is accepted (p1910 = 1)
r1912 identified stator resistance	p0350 motor stator resistance, cold+ p0352 cable resistance
r1913 rotor time constant identified	r0384 motor rotor time constant / damping time constant, d axis
r1915 stator inductance identified	-
r1925 threshold voltage identified	-
r1927 rotor resistance identified	r0374 motor resistance cold (gamma) p0354
r1932 d inductance	r0377 motor leakage inductance total (gamma) p0353 motor series inductance p0356 motor leakage inductance p0358 motor rotor leakage inductance p1715 current controller P gain p1717 current controller integral time
r1934 q inductance identified	-
r1936 magnetizing inductance identified	r0382 motor magnetizing inductance transformed (gamma) p0360 motor magnetizing inductance p1590 flux controller P gain p1592 flux controller integral time
r1973 encoder pulse number identified	-
Note: The encoder pulse number is only determined with a very high degree of inaccuracy (p0407/p0408) and is only suitable for making rough checks. The sign is negative if inversion is required (p0410.0).	
-	p0410 Encoder inversion actual value
Note: If the encoder inversion is changed using motor data identification, fault F07993 is output, which refers to a possible change in the direction of rotation and can only be acknowledged by p1910 = -2.	

4.12 Motor data identification

Table 4- 13 Data determined using p1960 for induction motors (rotating measurement)

Determined data (gamma)	Data that is accepted (p1960 = 1)
r1934 q inductance identified	-
r1935 q inductance identification current	
Note: The q inductance characteristic can be used as basis to manually determine the data for the current controller adaptation (p0391, p0392 and p0393).	
r1936 magnetizing inductance identified	r0382 motor magnetizing inductance transformed (gamma) p0360 motor magnetizing inductance p1590 flux controller P gain p1592 flux controller integral time
r1948 magnetizing current identified	p0320 rated motor magnetizing current
r1962 saturation characteristic magnetizing current identified	-
r1963 saturation characteristic stator inductance identified	-
Note: The magnetic design of the motor can be identified from the saturation characteristic.	
r1969 moment of inertia identified	p0341 motor moment of inertia * p0342 ratio between the total moment of inertia and that of the motor + p1498 load moment of inertia
r1973 encoder pulse number identified	-
Note: The encoder pulse number is only determined with a very high degree of inaccuracy (p0407/p0408) and is only suitable for making rough checks. The sign is negative if inversion is required (p0410.0).	

4.12.2 Motor data identification synchronous motor

Table 4- 14 Data determined using p1910 for synchronous motors (standstill measurement)

Determined data	Data that is accepted (p1910 = 1)
r1912 stator resistance identified	p0350 motor stator resistance, cold + p0352 cable resistance
r1925 threshold voltage identified	-
r1932 d inductance	p0356 motor stator leakage inductance + p0353 motor series inductance p1715 current controller P gain p1717 current controller integral time
r1934 q inductance identified	-
r1950 voltage emulation error voltage values	p1952 voltage emulation error, final value
r1951 voltage emulation error, current values	p1953 voltage emulation error, current offset
Note regarding r1950 to p1953: Active when the function module "extended torque control" is activated and activated compensation of the voltage emulation error (p1780.8 = 1).	
r1973 encoder pulse number identified	-
Note: The encoder pulse number is only determined with a very high degree of inaccuracy (p0407/p0408) and is only suitable for making rough checks. The sign is negative if inversion is required (p0410.0).	
r1984 pole position identification angular difference	p0431 commutation angle offset
Note: r1984 indicates the difference of the commutation angle offset before being transferred into p0431.	
-	p0410 encoder inversion actual value
Note: If the encoder inversion is changed using motor data identification, fault F07993 is output, which refers to a possible change in the direction of rotation and can only be acknowledged by p1910 = -2.	

4.12 Motor data identification

Table 4- 15 Data determined using p1960 for synchronous motors (rotating measurement)

Determined data	Data that is accepted (p1960 = 1)
r1934 q inductance identified	-
r1935 q inductance identification current	-
Note: The q inductance characteristic can be used as basis to manually determine the data for the current controller adaptation (p0391, p0392 and p0393).	
r1937 torque constant identified	p0316 motor torque constant
r1938 voltage constant identified	p0317 motor voltage constant
r1939 reluctance torque constant identified	p0328 motor reluctance torque constant
r1947 optimum load angle identified	p0327 optimum motor load angle
r1969 moment of inertia identified	p0341 motor moment of inertia * p0342 ratio between the total moment of inertia and that of the motor + p1498 load moment of inertia
r1973 encoder pulse number identified	-
Note: The encoder pulse number is only determined with a very high degree of inaccuracy (p0407/p0408) and is only suitable for making rough checks. The sign is negative if inversion is required (p0410.0).	
r1984 pole position identification angular difference	p0431 commutation angle offset
Note: r1984 indicates the difference of the commutation angle offset before being transferred into p0431.	

For linear motors (p0300 = 4xx), p1959 is pre-set so that only the q inductance, the commutation angle offset and the high inertia mass are measured (p1959.05 = 1 and p1959.10 = 1), as generally the travel limits do not permit longer travel distances in one direction.

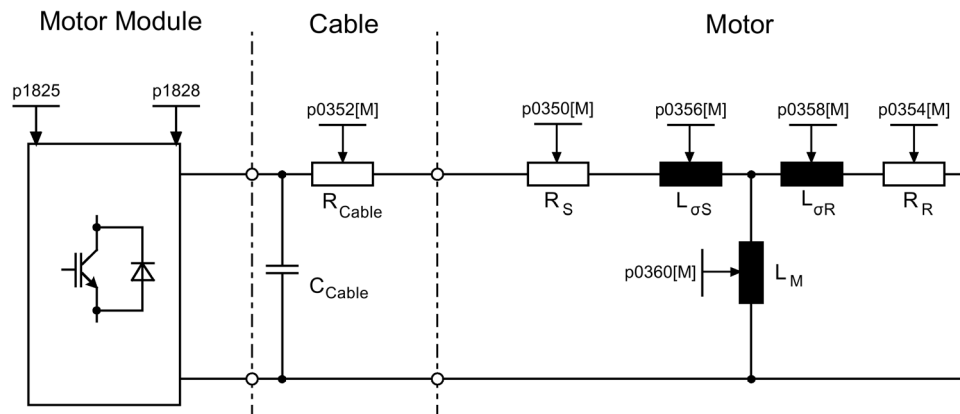

Figure 4-17 Equivalent circuit diagram for induction motor and cable

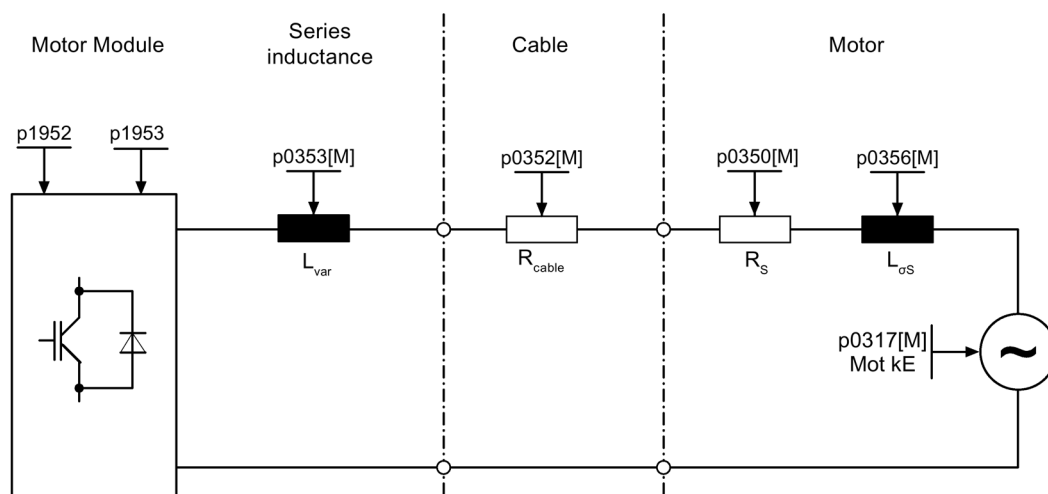

Figure 4-18 Equivalent circuit diagram for synchronous motor and cable

Overview of important parameters (see SINAMICS S120/S150 List Manual)

- r0047 Identification status
- Standstill measurement**
- p1909[0...n] Motor data identification, control word
- p1910 Motor data identification, stationary
- Rotating measurement**
- p1958[0...n] Rotating measurement ramp-up/ramp-down time
- p1959[0...n] Rotating measurement configuration
- p1960 Rotating measurement selection

4.13 Pole position identification

For synchronous motors, the pole position identification determines its electrical pole position that is required for the field-oriented control. Generally, the electrical pole position is provided from a mechanically adjusted encoder with absolute information.

A one-off pole position identification run is required for motors with encoders that are either not calibrated or have not been adjusted.

1. Select a procedure with p1980.
2. Start the one-off pole position identification by setting p1990 = 1.

The value in p1982 is not taken into account.

For Siemens 1FN1, 1FN3 and 1FN6 linear motors, p1990 is automatically set to 1 after commissioning or after an encoder has been replaced.

For the following encoder properties, pole position identification is not required:

- Absolute encoder (e.g. EnDat, DRIVE-CLiQ encoder)
- Encoder with C/D track and pole pair number ≤ 8
- Hall sensor
- Resolver with a multiple integer ratio between the motor pole pair number and the encoder pole pair number
- Incremental encoder with a multiple integer ratio between the motor pole pair number and the encoder pulse number

The pole position identification is used for:

- Determining the pole position (p1982 = 1)
- Determining the commutation angle offset during commissioning (p1990 = 1)
- Plausibility check for encoders with absolute information (p1982 = 2)

WARNING

Danger to life as a result of motor movement when carrying out measurements at motors that are not braked

When the motors are not braked, the motor can move as a result of the current impressed during the measurement. This can result in death or severe injury.

- Ensure that nobody is in the hazardous zone - and that the mechanical system can freely move.

Note

Use default setting

When using standard Siemens motors, the automatically pre-selected setting should be kept.

4.13.1 Notes regarding pole position identification

The relevant procedure can be selected using parameter P1980. The following procedures are available for pole position identification:

- Saturation-based 1st + 2nd harmonics (p1980 = 0)
- Saturation-based 1st harmonic (p1980 = 1)
- Saturation-based, two-stage (p1980 = 4)
- Motion-based (p1980 = 10)
- Elasticity-based (p1980 = 20)

The following supplementary conditions apply to the saturation-based motion procedure:

- This procedure can be used for both braked and non-braked motors.
- It can only be used for a speed setpoint = 0 or from standstill.
- The specified current magnitudes (p0325, p0329) must be sufficient to provide a significant measuring result.
- For motors without iron, the pole position cannot be identified using the saturation-based procedure.
- For 1FN3 motors, it is not permissible to traverse with the 2nd harmonic (p1980 = 0, 4).
- With 1FK7 motors, a two-stage procedure must not be used (p1980 = 4). The value in p0329, which is set automatically, must not be reduced.

For the motion-based procedure, the following supplementary conditions apply:

Note

Inaccuracy when determining the commutation angle

If several 1FN3 linear motors are coupled with one another, and at the same time saturation-based pole position identification is used for commutation (p1980 ≤ 4 and p1982 = 1), then this can influence the DC link voltage. Fast current changes in the DC link cannot be completely compensated. In this case, the commutation angle is not precisely determined using the pole position identification.

- If a high precision is required, then carry out the pole position identification routines one after the other. This can be achieved, for example, by enabling the individual drives one after the other (with a time offset).
-

- The motor must be free to move and it may not be subject to external forces (no hanging/suspended axes).
- It can only be used for a speed setpoint = 0 or from standstill.
- If there is a motor brake, then this must be open (p1215 = 2).
- The specified current magnitude (p1993) must move the motor by a sufficient amount.

For the elasticity-based procedure, the following supplementary conditions apply:

- A brake must be available and must also be closed during the pole position identification. Either the drive controls the brake ($p1215 = 1$ or 3) or the brake is externally closed well in advance of the start of the pole position identification and is re-opened after the operation has been completed.
- Parameters $p3090$ to $p3096$ must be correctly set for a successful pole position identification.
- The specified current magnitude ($p3096$) must deflect the motor by a sufficient amount.
- The ratio between the sign of the deflection and the force/torque must be taken into account in $p3090.0$.

 **WARNING**

Danger to life as a result of an incorrect control sense of the speed control loop

If, to determine the commutation angle, the pole position identification routine is used, then the commutation angle must be redetermined each time that the control sense is changed. An incorrect commutation angle can lead to uncontrollable motor movement - and therefore result in death or severe injury.

- Check the commutation angle offset ($F7966$) after an actual value inversion, and when necessary redetermine the offset ($p1990 = 1$).

Pole position correction with zero marks

The pole position identification routine provides coarse synchronization. If zero marks exist, the pole position can be automatically compared with the zero mark position once the zero mark(s) have been passed (fine synchronization). The zero mark position must be either mechanically or electrically ($p0431$) calibrated. If the encoder system permits this, then we recommend fine synchronization ($p0404.15 = 1$). This is because it avoids measurement spread and allows the determined pole position to be additionally checked.

Suitable zero marks

- One zero mark in the complete traversing range
- Equidistant zero marks
- Distance-coded zero marks

Selecting the reference mark for fine synchronization for determining the pole position using zero marks

A precondition for determining the pole position using zero marks is that the zero mark distance of the encoder is a multiple integer of the pole pitch / pole pair width of the motor.

For example, for linear motors with measuring systems where this is not available, the drive permits the zero mark which is used for the reference point approach, to be used for fine synchronization. With this zero mark, due to the mechanical arrangement, the commutation angle = 0 or is available as offset in p0431.

This procedure is available for absolute encoders (with the exception of DRIVE-CLiQ encoders), incremental encoders with equidistant zero mark and resolvers.

The sequence is then as follows:

1. Set the "Commutation with selected zero mark" mode in p0430.24.
2. Via the PROFIdrive encoder interface, the drive receives the request for a reference mark search.
3. Together with the Sensor Module, the drive determines the reference mark as a result of the parameterization.
4. The drive provides the reference mark position via the PROFIdrive encoder interface.
5. The drive transfers the same position to the Sensor Module.
6. The Sensor Module corrects the commutation angle (fine synchronization).

4.13.2 Pole position identification technique

Determining the suitable procedure for the pole position identification

	Saturation-based	Motion-based	Elasticity-based
Brake available	Possible	Not possible	Required
Motor can freely move	Possible	Required	Not possible
Motor has no iron	Not possible	Possible	Possible

Important parameters depending on the pole position identification procedure

	Saturation-based	Motion-based	Elasticity-based
p0325	+	-	-
p0329	+	-	-
p1980	Value 0, 1 or 4	Value 10	Value 20
p1981	+	+	-
p1982	+	+	+
p1983	+	+	+
r1984	+	+	+
r1985	+	+	+
r1986	+	+	+
r1987	+	+	+
p1990	+	+	+
r1992	+	+	+
p1993	-	+	-
p1994	-	+	-
p1995	-	+	-
p1996	-	+	-
p1997	-	+	-
p3090	-	-	+
p3091	-	-	+
p3092	-	-	+
p3093	-	-	+
p3094	-	-	+
p3095	-	-	+
p3096	-	-	+
r3097	-	-	+
Marking + = relevant, - = not relevant			

4.13.3 Commutation angle offset commissioning support (p1990)

The function for determining the commutation angle offset is activated via p1990=1. The commutation angle offset is entered in p0431. This function can be used in the following cases:

- Single calibration of the pole position for encoders with absolute information (exception: The Hall sensor must always be mechanically adjusted.)
- Calibrating the zero mark position for fine synchronization

Table 4- 16 Mode of operation of p0431

	Incremental without zero mark	Incremental with one zero mark	Incremental with distance-coded zero marks	Absolute encoder
C/D track	Shifts the commutation with respect to the C/D track	Shifts the commutation with respect to the C/D track and zero mark	Currently not available	Not permitted
Hall sensor	Does not influence the Hall sensor. The Hall sensor must be mechanically adjusted.	Does not influence the Hall sensor. Shifts the commutation with respect to the zero mark.	Does not influence the Hall sensor. Shifts the commutation with respect to the absolute position (after two zero marks have been passed).	Not permitted
Pole position identification	No effect	Shifts the commutation with respect to the zero mark	Shifts the commutation with respect to the absolute position (after two zero marks have been passed).	Shifts the commutation with respect to absolute position

Note

When fault F07414 occurs, p1990 is automatically started; if p1980 ≠ 99 and p0301 does not refer to a catalog motor with an encoder that is adjusted in the factory.

4.13.4 Overview of important parameters (see SINAMICS S120/S150 List Manual)

Overview of important parameters (see SINAMICS S120/S150 List Manual)

- p0325[0...n] Motor pole position identification current 1st phase
- p0329[0...n] Motor pole position identification current
- p0404[0...n] Encoder configuration active
- p0430[0...n] Sensor Module configuration
- p0431[0...n] Commutation angle offset
- p0437[0...n] Sensor Module extended configuration
- r0458 Sensor Module properties
- r0459 Sensor Module extended properties
- p0640[0...n] Current limit
- p1082[0...n] Maximum speed
- p1215 Motor holding brake configuration
- p1980[0...n] PolID procedure
- p1981[0...n] PolID maximum distance
- p1982[0...n] PolID selection
- p1983 PolID test
- r1984 PolID angular difference
- r1985 PolID saturation curve
- r1986 PolID saturation curve 2
- r1987 PolID trigger curve
- p1990 Encoder adjustment, determine commutation angle offset
- p1991[0...n] Motor changeover, commutation angle offset
- r1992.0...15 CO/BO: PolID diagnostics
- p1993[0...n] PolID motion-based current
- p1994[0...n] PolID motion-based rise time
- p1995[0...n] PolID motion-based gain
- p1996[0...n] PolID motion-based integral time
- p1997[0...n] PolID motion-based smoothing time
- p3090[0...n] PolID elasticity-based configuration
- p3091[0...n] PolID elasticity-based ramp time
- p3092[0...n] PolID elasticity-based wait time
- p3093[0...n] PolID elasticity-based measurement count

4.13 Pole position identification

- p3094[0...n] PolID elasticity-based deflection expected
- p3095[0...n] PolID elasticity-based deflection permitted
- p3096[0...n] PolID elasticity-based current
- r3097.0...31 BO: Pole ID elasticity-based status

4.14 Vdc control

Principle

The Vdc control monitors the DC voltage in the DC link for overvoltage and undervoltage. If an overvoltage or undervoltage is identified in the DC link line-up, a subsequent response can be set with the Vdc control via p1240.

The torque limits of the motors for which the Vdc controller is active can be affected if discrepancies in the DC link voltage are significant enough. The motors may no longer be able to maintain their setpoint speed or the acceleration/braking phases are prolonged.

In a drive line-up, one or more drives can be used to relieve or support the DC link. This allows a fault due to an unfavorable DC link voltage to be avoided. The drives remain ready for operation.

Generally, a maximum motoring power p_{mot} of the Motor Module from the DC link is given by

$$P_{mot} = V_{DC, actual\ value} \times (V_{DC, actual\ value} - p1248) \times p1250$$

Correspondingly, a maximum regenerative feedback power P_{gen} of the Motor Module into the DC link of

$$P_{gen} = V_{DC, actual\ value} \times (p1244 - V_{DC, actual\ value}) \times p1250 \text{ is obtained}$$

The V_{dc} controller is a P controller that influences the torque limits. It only intervenes when the DC link voltage approaches the "upper threshold" (p1244) or "lower threshold" (p1248) and the corresponding controller is activated with p1240.

The recommended setting for the P gain is $p1250 = 0.5 \times \text{DC link capacitance [mF]}$.

Once the DC link has been identified (p3410), the DC link capacitance can be read in parameter p3422 in the Infeed Module.

Note

To ensure that the drives remain active if the Line Module has failed, the response to fault F07841 must be changed to "none" or the operation message from the Infeed Module must be permanently set to "1" with p0864.

The V_{dc} controller can be used, for example, when a Line Module without energy feedback capability (V_{dc_max} controller) is used and as a safety measure in the event of a power failure (V_{dc_min} and V_{dc_max} controller). To ensure that critical drives can be operated for as long as possible, parameterizable faults exist that switch off individual drives if there is a problem with the DC link.

The voltage limit values for V_{dc} control also have an impact on V/f control, although the dynamic response of V_{dc} control is slower in this case.

V_{dc_min} control

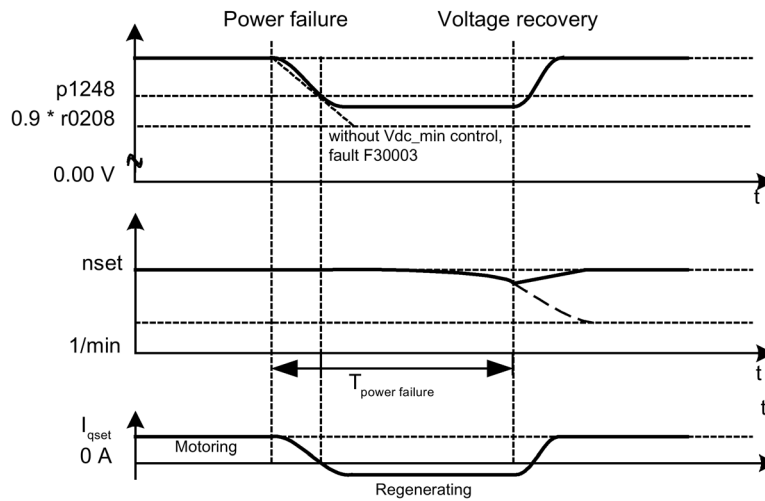

Figure 4-19 Switching V_{dc_min} control on/off (kinetic buffering)

In the event of a power failure, the Line Module can no longer supply the DC link voltage, particularly if the Motor Modules in the DC link line-up are drawing active power. To maintain the DC link voltage in the event of a power failure (e.g. for a controlled emergency retraction), the V_{dc_min} controller can be activated for one or more drives (p1240 = 2, 3). When the set voltage threshold of p1248 is fallen below, these drives are switched into the generator mode so that they can buffer the DC link voltage with their kinetic energy. The threshold should be set considerably higher than the shutdown threshold of the Motor Modules (recommendation: 50 V below the DC link voltage). When the line supply returns, the V_{dc} controller is automatically inactive. The drives approach the speed setpoint again. If the line supply does not return, then the DC link voltage collapses as soon as the kinetic energy of the drives is exhausted with an active V_{dc_min} controller.

Note

If it is expected that the line supply will return, you must make sure that the drive lineup is not disconnected from the line supply. It could become disconnected, for example, if the line contactor drops out. The line contactor must be supplied, e.g. from an uninterruptible power supply (UPS).

V_{dc_min} control without braking

As for V_{dc_min} control with braking, however, active motor braking can be prevented by reducing the DC link voltage (p1240 = 8, 9). The effective upper torque limit must not be less than the torque limit offset (p1532). The motor does not go into the generator mode and does not draw any active power from the DC link.

V_{dc_max} control

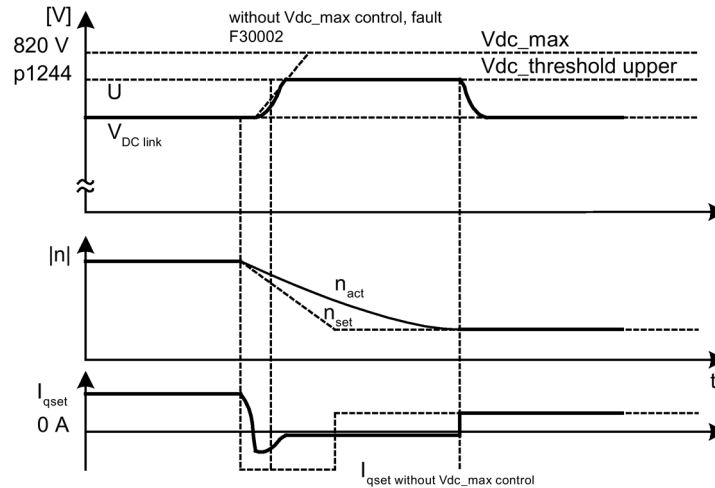

Figure 4-20 Switching the V_{dc_max} control on/off

With Infeed Modules without feedback or in the event of a power failure, the DC link voltage can increase until it reaches the shutdown threshold when drives in the DC link line-up are decelerated. To prevent the system from shutting down due to a DC link overvoltage, the V_{dc_max} controller can be activated for one or more drives (p1240 = 1, 3). The V_{dc_max} controller is normally activated for drives that have to decelerate/accelerate high levels of kinetic energy themselves. When the overvoltage threshold in p1244 is reached (recommended setting: 50 V higher than the DC link voltage), the braking torque of the drives with an active V_{dc_max} controller is reduced by shifting the torque limit. These drives feed back exactly the same amount of energy, that is drawn as a result of losses or loads in the DC link. This function minimizes the braking time.

Note

If other drives in the drive line-up, where the V_{dc_max} controller is not active, feed energy back, the drives with an active V_{dc_max} controller can even be accelerated to absorb the braking energy and, in turn, relieve the DC link.

V_{dc_max} control without acceleration

As for the normal V_{dc_max} control (p1240 = 1, 3), if the drive must not be accelerated by means of feedback from other drives in the DC link, acceleration can be prevented by the setting p1240 = 7, 9. The effective lower torque limit must not be greater than the torque limit offset (p1532).

V_{dc} controller monitoring

In the event of a power failure, the Line Module can no longer supply the DC link voltage, particularly if the Motor Modules in the DC link line-up are drawing active power. To ensure that the DC link voltage is not burdened with uncritical drives in the event of a power failure, these drives can be switched off by a fault (F30003) with a parameterizable voltage threshold (p1248). This is carried out by activating the V_{dc_min} monitoring function (p1240 = 5, 6).

In the event of a power failure, the DC link voltage can increase until it reaches the shutdown threshold when drives are decelerated. To ensure that the DC link voltage is not loaded with uncritical drives in the event of a power failure, these drives can be switched off with fault F30002 with a parameterizable voltage threshold in p1244. This is done by activating the V_{dc_max} monitoring (p1240 = 4, 6).

Function diagrams (see SINAMICS S120/S150 List Manual)

- 5300 Servo control - V/f control for diagnostics
- 5650 Servo control - V_{dc_max} controller and V_{dc_min} controller

Overview of important parameters (see SINAMICS S120/S150 List Manual)

- r0056.14 CO/BO: Status word, closed-loop control: V_{dc_max} controller active
- r0056.15 CO/BO: Status word, closed-loop control: V_{dc_min} controller active
- p1240[0...n] V_{dc} controller or V_{dc} monitoring configuration
- p1244[0...n] Upper DC link voltage threshold
- p1248[0...n] Lower DC link voltage threshold
- p1250[0...n] V_{dc} controller proportional gain

4.15 Dynamic Servo Control (DSC)

The function Dynamic Servo Control" (DSC) is a closed-loop control structure which is computed in a fast speed controller cycle and is supplied with setpoints by the controller in the position controller cycle.

This allows higher position controller gain factors to be achieved.

Requirements

The following prerequisites are necessary to use the "Dynamic Servo Control" function:

- n-set mode
- Isochronous PROFIBUS DP or PROFINET IO with IRT
- The position controller gain factor (KPC) and the position deviation (XERR) must be included in the setpoint telegram of PROFIBUS DP or PROFINET IO with IRT (refer to p0922).
- The actual position value must be transferred to the master in the actual value telegram of PROFIBUS DP or PROFINET IO with IRT via the encoder interface Gx_XIST1.
- When DSC is activated, the speed setpoint N_SOLL_B from the PROFIdrive telegram from PROFIBUS DP or PROFINET IO with IRT is used as a speed precontrol value.
- The internal quasi position controller, DSC position controller (FP3090), uses the actual position value G1_XIST1 from the motor measuring system or the actual position value from an additional encoder system (telegrams 6, 106, 116, 118, 126, 136 and 138 or free telegrams).

The following PROFIdrive telegrams support DSC:

- Standard telegrams 5 and 6
- SIEMENS telegrams 105, 106, 116, 118, 125, 126, 136, 138, 139

Further PZD data telegram types can be used with the telegram extension. It must then be ensured that SERVO supports a maximum of 20 PZD setpoints and 28 PZD actual values.

Note

Synchronization is required on the control side and on the drive side for the operation of DSC.

A detailed description of the DSC mode of operation is provided in function diagram 3090 (see SINAMICS S120/S150 List Manual).

Operating states

The following operating states are possible for DSC (for details, see function diagram 3090 in the SINAMICS S120/S150 List Manual):

Operating state for DSC	Meaning
Speed/torque precontrol with linear interpolation	As a result of the step-like torque precontrol in the position controller cycle, a pulsed torque characteristic is obtained with the excitation cycle.
Speed precontrol with splines ¹⁾	<ul style="list-style-type: none"> • The position setpoint is made symmetrical. • The speed precontrol value is not made symmetrical.
Speed/torque precontrol with splines ¹⁾	<ul style="list-style-type: none"> • The position setpoint is made symmetrical. • The speed precontrol value is made symmetrical.²⁾ • The torque precontrol value is not made symmetrical.

- 1) The following improvements are obtained as a result of the spline interpolation:
- A finer interpolation of the torque in the speed controller cycle and so smoother movements and the avoidance of the impact torques.
 - Very high path accuracy for torque speed precontrol (i.e. smaller following error in the control behavior).
 - High-frequency path movements are possible
- 2) For active symmetrization ($T_SYMM > 0$), using p1427 you can set an additive symmetrizing time constant T_SYMM_ADD to symmetrize the speed precontrol value when torque precontrol is active.
- In this case, the speed precontrol value is symmetrized with the sum of the following time constants:
- T_SYMM (see p1195) + T_SYMM_ADD (p1427) + $0.5 \times T_speed_controller_cycle$ (p0115[1])
- The speed generation is considered automatically using the position differences with a half speed controller cycle.

Activation

If the preconditions for dynamic servo control are fulfilled, then the DSC structure is activated using a logical interconnection of the following parameters via a selected PROFIdrive telegram:

- p1190 "DSC position deviation XERR"
- p1191 "DSC position controller gain KPC"
- p1194 "CI: DSC control word DSC_STW"
- p1195 "CI: DSC symmetrizing time constant T_SYMM"
- p1430 "CI: Speed precontrol"

If $KPC = 0$ is transferred, only speed control with the speed precontrol values can be used (p1430, PROFIdrive N_SOLL_B and p1160 n_set_2). Position-controlled operation requires a transfer of $KPC > 0$.

Note**KPC when DSC is activated**

After activating dynamic servo control, check the position controller gain KPC in the master. It may be necessary to correct the setting.

Channel p1155 for speed setpoint 1, as well as channel r1119 for the extended setpoint, are disconnected when DSC is active.

When DSC is activated, p1160 for speed setpoint 2 and p1430 for the speed precontrol are added to the speed setpoint from the DSC, see function diagram 3090.

Deactivation

If the interconnection is removed at the connector input for KPC or XERR (p1191 = 0 or p1190 = 0), the DSC structure is dissolved and the "DSC" function deactivated. The sum from r1119 and p1155 is then added to the values from p1160 and p1430 from the speed precontrol.

Since it is possible to set higher gain factors using DSC, the control loop can become unstable when DSC is disabled. For this reason, before deselecting DSC, the value for KPC in the master must be reduced.

Speed setpoint filter

A speed setpoint filter for smoothing the speed setpoint steps is not required when DSC is active.

When using the "DSC" function, it only makes sense to use speed setpoint filter 1 to support the position controller, e.g. to suppress resonance effects.

External encoder systems (except motor encoder)

If, with DSC active, an external encoder is to be used, this requires the selection of a telegram with additional actual encoder values: Telegrams 6,106,116,118, 126, 138 or free telegrams.

For optimum control in the DSC mode, the same encoder(s) (encoder 2 and/or encoder 3) must be selected for the control (master) and the drive via parameter p1192 "DSC encoder selection".

If the encoder for the position actual value generation in the control and the encoder selected for DSC differ regarding their pulse numbers and/or fine resolution, then this must be taken into account in p1193. The factor represents the ratio of the pulse difference between the encoders used for the same distance reference. Further, it should be noted that for different encoders there are no dead times regarding their position actual value sensing (for example as is the case for EnDat encoders and SSI encoders), as this will otherwise lead to undesirable behavior.

The effect of the parameters p1192 and p1193 is illustrated in function diagram 3090.

Wind-up effect

If the drive reaches its torque limits when in the DSC mode, e.g. because of excessively fast setpoint inputs, then positioning motion can be overshoot. With this so-called wind-up effect, the drive overshoots the specified target, the controller enters a specific correction, the drive reverses, overshoots the target again, etc. In order to avoid this behavior, the drive limits the position controller to values that the drive can always reliably maintain depending on the acceleration capability. Set $p1400.17 = 1$ to activate dynamic setpoint limiting in the DSC mode. In this case, the total weight (m_{tot}) must be precisely parameterized (determine the weight $p0341$, $p0342$ and $p1498$ possibly using the m_{ot} ID). If the limiting responds, then this is indicated in $r1407.19$. On this topic, also observe the description of parameter $p1400.17$ and function diagram 3090.

Diagnostics

Parameter $r1407$ indicates which DSC closed-loop control structure is active, e.g. $r1407.20 = 1$ means "DSC with Spline on".

Requirements for the display:

- $p1190$ and $p1191$ must be connected to a signal source with a value of > 0 (DSC structure activated).
- OFF1, OFF3 and STOP2 must not be active.
- The motor data identification must not be active.
- Master control must not be active.

The following conditions can mean that although the bit is set, the DSC function is not active:

- Isochronous mode has not been selected ($r2054 \neq 4$).
- PROFIBUS is not isochronous ($r2064[0] \neq 1$).
- On the control side, DSC is not active, which causes the value of $KPC = 0$ to be transferred to $p1191$.

Function diagrams (see SINAMICS S120/S150 List Manual)

- 2401 PROFIdrive overview
- 2415 PROFIdrive - Standard telegrams and process data 1
- 2416 PROFIdrive - Standard telegrams and process data 2
- 2419 PROFIdrive - Manufacturer-specific telegrams and process data 1
- 2420 PROFIdrive - Manufacturer-specific telegrams and process data 2
- 2421 PROFIdrive - Manufacturer-specific telegrams and process data 3
- 2422 PROFIdrive - Manufacturer-specific telegrams and process data 4
- 2423 PROFIdrive - Manufacturer-specific/free telegrams and process data
- 3090 Setpoint channel - Dynamic Servo Control (DSC) linear and DSC Spline ($r0108.6 = 1$)
- 5020 Servo control - Speed setpoint filter and speed precontrol
- 5030 Servo control - Reference model/precontrol balancing/speed limiting

Overview of important parameters (see SINAMICS S120/S150 List Manual)

- p1160[0...n] CI: Speed controller, speed setpoint 2
- p1190 CI: DSC position deviation XERR
- p1191 CI: DSC position controller gain KPC
- p1192[0...n] DSC encoder selection
- p1193[0...n] DSC encoder adaptation factor
- p1194 CI: DSC control word DSC_STW
- p1195 CI: DSC symmetrizing time constant T_SYMM
- p1400[0...n] Speed control configuration
 - 17 DSC position controller limiting active
- r1407.0...26 CO/BO: Status word, speed controller
 - 04 Speed setpoint from DSC
 - 19 DSC position controller limited
 - 20 DSC with spline on
 - 21 Speed precontrol for DSC with spline on
 - 22 Torque precontrol for DSC with spline on
- p1430[0...n] CI: Speed precontrol

4.16 Travel to fixed stop

This function can be used to move a motor to a fixed stop at a specified torque without a fault being signaled. When the stop is reached, the specified torque is established and is then continuously available.

The desired torque derating is brought about by scaling the upper/motor-mode torque limit and the lower/regenerative-mode torque limit.

Application examples

- Screwing parts together with a defined torque.
- Moving to a mechanical reference point.

Signals

For PROFIdrive telegrams 2 to 6, the following signals are automatically interconnected:

- Control word 2, bit 8 (STW2.8)
- Status word 2, bit 8 (ZSW2.8)

For PROFIdrive telegrams 102 to 106, the following signals are also interconnected:

- Message word, bit 1 (MELDW1)
- Process data M_red to the scaling of the torque limit

When the "basic positioner" function module is activated, the signals listed above are automatically interconnected to the basic positioner.

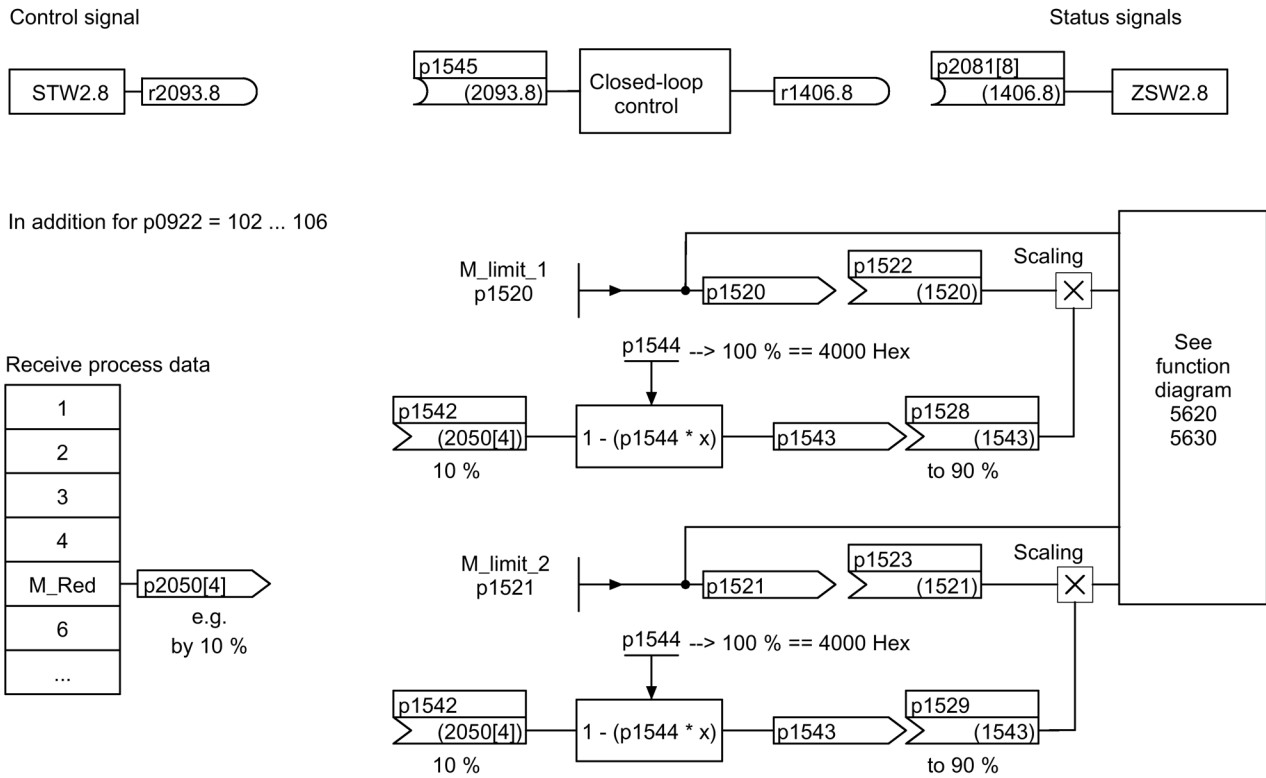

Figure 4-21 Signals for "Travel to fixed stop"

When PROFIdrive telegrams 2 to 6 are used, no torque reduction is transferred. When the "Travel to fixed stop" function is activated, the motor ramps up to the torque limits specified in p1520 and p1521. If the torque has to be reduced, protocols 102 to 106, for example, can be used to transfer it. Another option would be to enter a fixed value in p2900 and interconnect it to the torque limits p1528 and p1529.

Signal chart

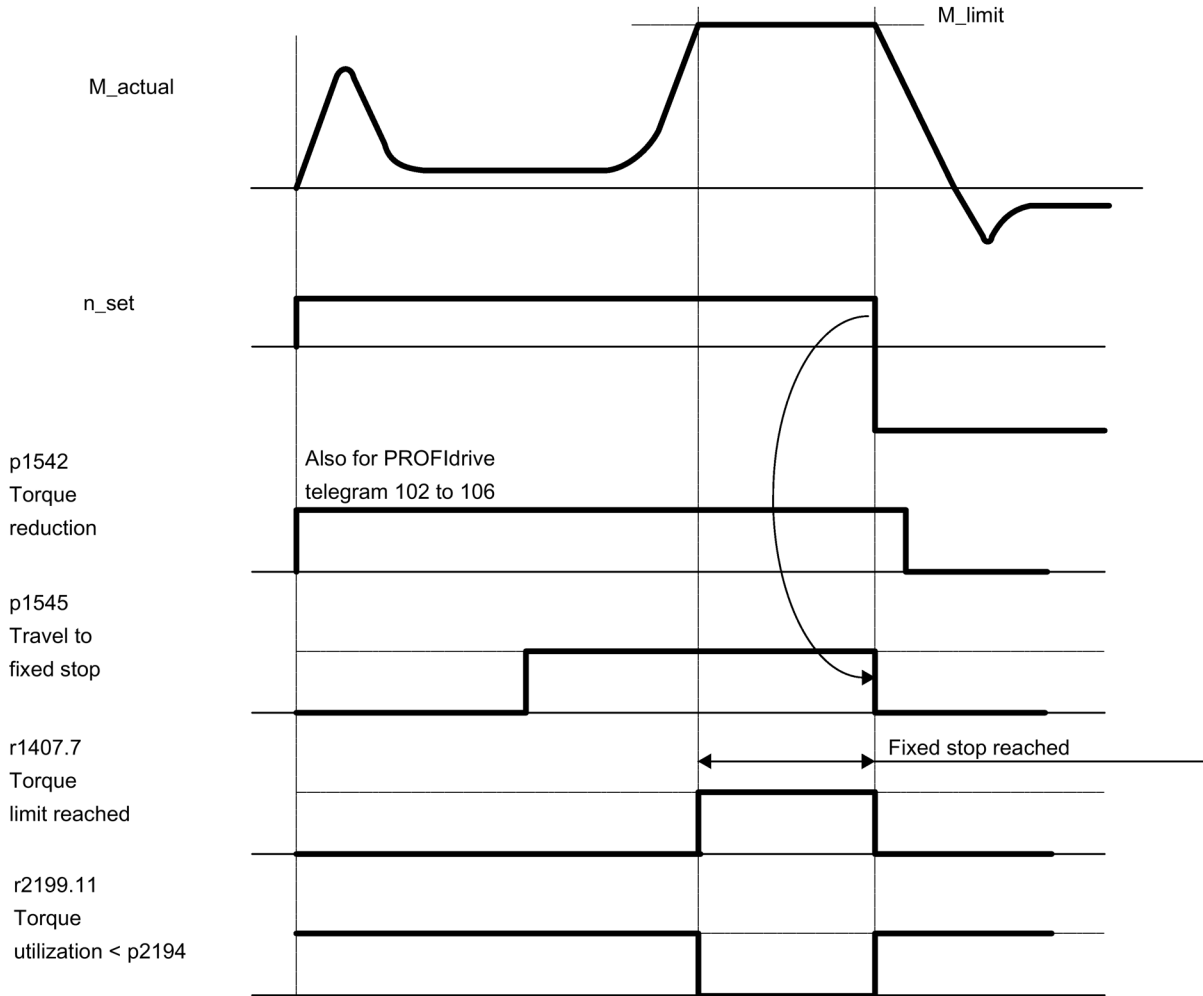

Figure 4-22 Signal chart for "Travel to fixed stop"

Commission PROFIdrive telegrams 2 to 6

1. Activate the "Travel to fixed stop" function via the parameter setting p1545 = "1".
2. Set the required torque limit.

Example:

p1400.4 = 0 → upper or lower torque limit

p1520 = 100 Nm → effective in upper positive torque direction

p1521 = -1500 Nm → effective in lower negative torque direction

3. Traverse the motor to stop.

The motor runs at the set torque until it reaches the stop and continues to work against the stop until the torque limit has been reached, this status being indicated in status bit r1407.7 "Torque limit reached".

Control and status messages

Table 4- 17 Control: Travel to fixed stop

Signal name	Internal control word STW n_ctrl	Binector input	PROFIdrive p0922 and/or p2079
Activate travel to fixed stop	8	p1545 Activate travel to fixed stop	STW2.8

Table 4- 18 Status message: Travel to fixed stop

Signal name	Internal status word	Parameter	PROFIdrive p0922 and/or p2079
Travel to fixed stop active	-	r1406.8	ZSW2.8
Torque limits reached	ZSW n_ctrl.7	r1407.7	ZSW1.11 (inverted)
Torque utilization < torque threshold value 2	ZSW monitoring functions 3.11	r2199.11	MELDEW.1

Function diagrams (see SINAMICS S120/S150 List Manual)

- 5609 Servo control, generation of the torque limits, overview
- 5610 Servo control – torque limiting/reduction, interpolator
- 5620 Servo control - Motoring/generating torque limit
- 5630 Servo control - Upper/lower torque limit
- 8012 Signals and monitoring functions – Torque messages, motor locked/stalled

Overview of important parameters (see SINAMICS S120/S150 List Manual)

- p1400[0...n] Speed control configuration
- r1407.7 CO/BO: Status word speed controller;
torque limit reached
- p1520[0...n] CO: Torque limit, upper/motoring
- p1521[0...n] CO: Torque limit, lower/regenerative
- p1522[0...n] CI: Torque limit, upper/motoring
- p1523[0...n] CI: Torque limit, lower/regenerative
- r1526 CO: Torque limit, upper/motoring without offset
- r1527 CO: Torque limit, lower/regenerative without offset
- p1532[0...n] Torque limit, offset
- p1542[0...n] CI: Travel to fixed stop, torque reduction
- r1543 CO: Travel to fixed stop, torque scaling
- p1544 Travel to fixed stop, evaluation torque reduction
- p1545[0...n] BI: Activate travel to fixed stop
- p2194[0...n] Torque threshold value 2
- p2199.11 CO/BO: Status word monitoring;
Torque utilization < torque threshold value 2

4.17 Vertical axes

With a vertical axis without mechanical weight compensation, electronic weight compensation can be set by offsetting the torque limits (p1532). The torque limits specified in p1520 and p1521 are shifted by this offset value.

The offset value can be read in r0031 and transferred in p1532.

To reduce compensation once the brake has been released, the torque offset can be interconnected as a supplementary torque setpoint (p1511 or p1513). In this way, the holding torque is set as soon as the brake has been released.

Function diagrams (see SINAMICS S120/S150 List Manual)

- 5060 Servo control - Torque setpoint, switchover control mode
- 5620 Servo control - Motoring/generating torque limit
- 5630 Servo control - Upper/lower torque limit

Overview of important parameters (see SINAMICS S120/S150 List Manual)

- r0031 Actual torque smoothed
- p1511[0...n] CI: Supplementary torque 1
- p1512[0...n] CI: Supplementary torque 1 scaling
- p1513[0...n] CI: Supplementary torque 2
- p1520[0...n] CO: Torque limit, upper/motoring
- p1521[0...n] CO: Torque limit, lower/regenerative
- p1532[0...n] CO: Torque limit, offset

4.18 Variable signaling function

Variable signaling function for monitoring

Using the "Variable signaling" function, BICO interconnections and parameters that have the attribute "traceable" can be monitored; otherwise they can also be recorded using the "Device trace" commissioning function.

Note

The variable signaling function works with an accuracy of 8 ms (also to be taken into account for pickup and dropout delay).

Enter the desired data source into parameter p3291 of the drive object expert list. In parameter p3295 define a threshold value for the data source. The hysteresis of the threshold value can be set with p3296. If the threshold value is violated, then an output signal is generated from r3294.

A pickup delay can be set with p3297 and a dropout delay with p3298 for the output signal r3294.

The setting of a hysteresis results in a tolerance band around the threshold value. If the upper band limit is exceeded, the output signal r3294 is set to "1", if it drops below the lower band limit the output signal is set to "0"

You set the sampling time of the variable signaling function in p3299.

After completing the configuration, activate the variable signaling function with p3290.0 = 1.

Example 1:

Heating should be switched on depending on the temperature. For this the analog signal of an external sensor is connected with the variable signaling function. A temperature threshold and a hysteresis is defined to prevent the heating from switching on and off constantly.

Example 2:

The pressure as process variable is to be monitored, whereby a temporary overpressure is tolerated. For this, the output signal of an external sensor is connected with the variable signaling function. The pressure thresholds and a pull-in delay are set as tolerance time.

When the output signal of the variable signaling function is set, bit 5 in message word MELDW is set during cyclic communication. The message word MELDW is a component of the telegrams 102, 103, 105, 106, 110, 111, 116, 118, 126.

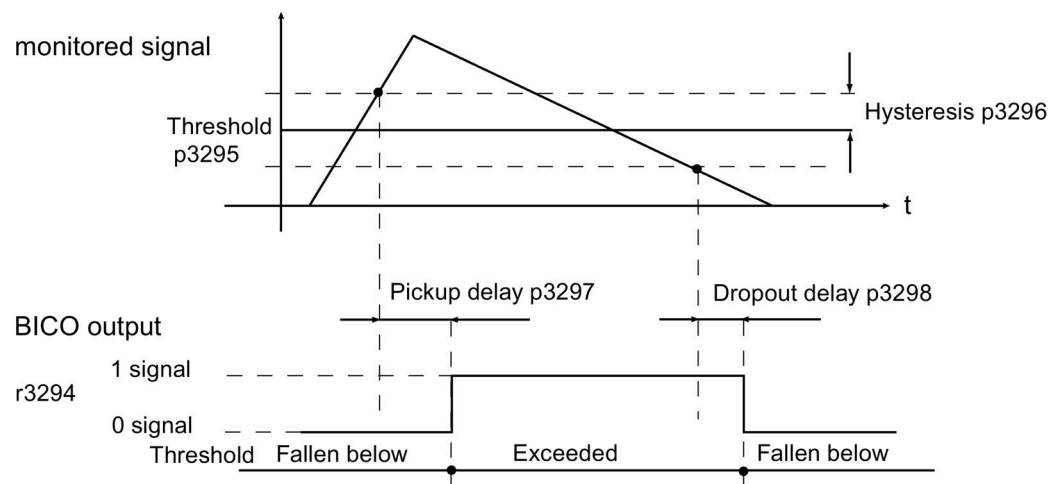

Figure 4-23 Variable signaling function

Function diagrams (see SINAMICS S120/S150 List Manual)

- 5301 Servo control - variable signaling function

Overview of important parameters (see SINAMICS S120/S150 List Manual)

- p3290 Variable signaling function, start
- p3291 CI: Variable signaling function signal source
- r3294 BO: Variable signaling function, output signal
- p3295 Variable signaling function, threshold value
- p3296 Variable signaling function, hysteresis
- p3297 Variable signaling function, pickup delay
- p3298 Variable signaling function, dropout delay
- p3299 Variable signaling function, sampling time

4.19 Central probe evaluation

Frequently, motion control systems have to detect and save the positions of drive axes at an instant in time defined by an external event. For example, this external event may be the signal edge of a probe. The following can be necessary:

- Several probes have to be evaluated
- The actual position values of several axes must be saved with a probe event.

For the central probe evaluation, the instant in time of the probe signal is detected and saved by a central function. From the sampling values of the position signals of the various axes, the control interpolates the times of the actual position values at the probe instant. Three evaluation procedures are implemented in SINAMICS S120 for this purpose.

The evaluation procedures can be set using parameter p0684:

Evaluation procedures	Parameter setting	Explanation
With handshake	p0684 = 0	Factory setting
Without handshake, two edges	p0684 = 1	A change to p0684 = 0 or 1 is possible in the RUN state.
Without handshake, more than two edges	p0684 = 16	Measuring several signal edges per probe, without handshake: A change to p0684 = 16 only becomes active after "Save parameters" and "POWER ON". A change of p0684 = 16 to p0684 = 0 or 1 only becomes active "After save parameters" and "POWER ON".

The fail safety of the standard PROFIdrive connection without handshake cannot be guaranteed. The "Without handshake" function has been released for "integrated" platforms (e.g. SINAMICS integrated in SIMOTION D425). You must use the "With handshake" function to ensure absolute reliability when detecting the probe.

PROFIdrive telegrams for the central measuring function

- Telegram 390: No probe
- Telegram 391: 2 probes (when p0684=0/1)
- Telegram 392: 6 probes (when p0684=0/1)
- Telegram 393: 8 probes (when p0684=0/1)
- Telegram 394: No probe
- Telegram 395: 16 probes, time stamp (p0684 = 16)

Common features for central measuring with and without handshake

Both measuring procedures have the following points in common:

- Setting the input terminal in p0680.
- Signal source, synchronization signal in p0681.
- Signal source, control word probe p0682.
- Transfer with the communication interface PROFIdrive.
- Synchronizing and monitoring isochronous PROFIdrive
- Prerequisite for measurements is the synchronization between the control and drive.
- Setpoint transfer at start time T_o and actual value transfer at instant in time T_i in the PROFIBUS cycle (max. 8 ms).
- Time stamp: Format (drive increments, NC decrements)
- Each valid time stamp in the drive is incremented by 1 in order to make a differentiation between a valid measuring time zero and an invalid time format. This increment is removed again by the higher-level control.
- The value "0" in the interface is an invalid time format and indicates that a measured value is not available.
- Sequencer for the control/status word processing
- Monitoring functions (sign of life)
- Faults

Note

Time-critical data transfer

The status information E_DIGITAL and A_DIGITAL in telegrams 39x are not subject to any precise time restraints according to the specifications. The transfer of E_DIGITAL and the output of A_DIGITAL is realized independently of the PROFIBUS cycle with the PROFIdrive PZD sampling rate according to p2048. Depending on the module, this can be set to between 1 ms and 16 ms. As a consequence, dead times must be expected for the transfer of output values and the feedback signal of input values.

Although the probe status word MT_ZSW is identical with the content of E_DIGITAL, it is however directly transferred in PZDs. As a consequence, for time-critical applications measuring probes or cams should be used.

Central measuring with handshake

With $p0684 = 0$, you activate the evaluation procedure with handshake for the central probe evaluation. You can evaluate a maximum of one positive and/or negative edge per probe within four DP cycles.

T_{DP} = PROFIBUS cycle (also DP cycle)

T_{MAPC} = master application cycle time (time grid, in which the master application generates new setpoints).

- Transfer, control word probe (BICO p0682 to PZD3) at the start instant T_0 in the MAPC cycle.
- The measurement is activated with a 0/1 transition of the control bit for a falling or rising edge in the probe control word.
- If the measurement is activated, in data bus cycle (e.g. PROFIBUS cycle: DP cycle) a check is made as to whether a measured value is available.
- If a measured value is available, then the time stamp is entered into either p0686 or p0687.
- The time stamp is transferred until the control bit for falling or rising edge is set to "0" in the control word. Then, the associated time stamp is set to "0".
- The measurement is deactivated by a 1/0 transition of the control bit in the probe control word.
- Transfer with PROFIdrive telegrams 391, 392 or 393.

Central measurement without handshake, two edges

With $p0684 = 1$, you activate the evaluation procedure without handshake for the central probe evaluation. You can evaluate a maximum of two edges per probe simultaneously within two DP cycles. Precondition:

$T_{DP} = T_{MAPC}$ (cycle ratio = 1:1, cycle reduction not possible).

If the measurement is activated, a check is made in the DP cycle as to whether a measured value was acquired:

- If a measured value is available, then the time stamp is entered in either p0686 or p0687 and a new measurement is automatically activated.
- If a measured value is not available, then the time stamp zero is entered into either p0686 or p0687.
- This means that a time stamp is only transferred once before it is overwritten with zero or a new time stamp.
- The measurement is immediately reactivated after the measured values have been read out.
- Parallel to acquiring new probe events, the measuring results are transferred to the higher-level control for one DP cycle without evaluating the success.
- For each probe, a maximum of one rising and one falling edge can be detected for each 2 DP cycles.
- Transfer with PROFIdrive telegrams 391, 392 or 393.

Central measurement without handshake, more than two edges

With $p0684 = 16$, you activate the evaluation procedure without handshake for the central probe evaluation. You can evaluate up to 16 signal edges from a maximum of 2 probes simultaneously within a DP cycle.

DP cycle = PROFIBUS cycle = T_{DP}

T_{MAPC} = master application cycle time (time grid, in which the master application generates new setpoints).

- For each probe, up to 8 rising and/or 8 falling edges can be detected in each DP cycle and saved in a measurement buffer.
- For each probe it can be selected whether the rising or falling signal edges are to be taken into account.
- The cyclic measurement is activated with a 0/1 transition of the control bit for the signal edges in the probe control word.
- After activating the measurement, the measured value buffer is emptied once for initialization.
- When the buffer is full, the oldest measured value is overwritten first (first in/first out). The bit "measured value buffer full" in the probe-diagnostic word signals the risk of losing measured values.
- The measured value buffer is then cyclically emptied and the measured values are converted in the sense of a measuring task into a time stamp. The time stamps are saved according to their chronological order, starting with the oldest, in the indexes of parameter $r0565[0...15]$ for the transfer.
- If several probes of being used, then the time stamps of the measurements are entered into the telegram block, corresponding to their chronological sequence, from the lowest up to the highest probe.
- Up to 16 time stamps (MT_ZS), can be entered into telegram 395.
- As soon as there is no longer any space for the time stamps of a probe in telegram 395, then the "Telegram full" is set in MT_DIAG.

Example:

- From the 1st probe 4 values are transferred
- From the 2nd probe 6 values are transferred
- From the 3rd only the first 6 values are transferred - the rest is cut off and "Full telegram" is signaled in MT_DIAG.
- From a selected probe, all signal edges are always taken into account. Individual signal edges cannot be selected or deselected.
- The time stamps are transferred in parallel (to acquire new probe events associated with a time stamp without handshake). A time stamp is only transferred for one DP cycle. Then the time stamp overwritten with zero or a new time stamp.
- The cyclic measurement is deactivated with a 1/0 transition of the control bit for a falling or rising signal edge in the probe control word.
- Transfer with PROFIdrive telegram 395.

The PZDs of the probe time stamp are BICO parameters, which are automatically connected with the indices of the new parameter $r0565[16]$ when the telegram block is selected.

After the measuring function has been activated, for several measured values per DP cycle, the acquired time stamps are saved in the indices of $r0565[0...15]$ for transfer, corresponding to their sequence in time starting with the oldest measured value.

Probe time stamp references

For telegram 395, the probe time stamps MT_ZS_1...16 are assigned to the telegram locations using the probe time stamp references MT_ZSB1...4.

Four probe time stamps each (MT_ZS) are assigned a probe time stamp reference (MT_ZSB):

Table 4- 19 Assignment, probe time stamp reference to time stamp

Probe time stamp reference	Probe time stamp	Bits
MT_ZSB1	Reference ZS1	Bits 0...3
	Reference ZS2	Bits 4...7
	Reference ZS3	Bits 8...11
	Reference ZS4	Bits 12...15
MT_ZSB2	Reference ZS5	Bits 0...3
	Reference ZS6	Bits 4...7
	Reference ZS7	Bits 8...11
	Reference ZS8	Bits 12...15
MT_ZSB3	Reference ZS9	Bits 0...3
	Reference ZS10	Bits 4...7
	Reference ZS11	Bits 8...11
	Reference ZS12	Bits 12...15
MT_ZSB4	Reference ZS13	Bits 0...3
	Reference ZS14	Bits 4...7
	Reference ZS15	Bits 8...11
	Reference ZS16	Bits 12...15

Table 4- 20 Bit assignment of MT_ZSB1 (r0566[0])

Reference time stamp	Probe bit, binary values	Edge selection bit
Reference MT_ZS1	Bits 0...2:	Bit 3:
	000: MT_ZS1 from MT1 001: MT_ZS1 from MT2 010: MT_ZS1 from MT3 011: MT_ZS1 from MT4 100: MT_ZS1 from MT5 101: MT_ZS1 from MT6 110: MT_ZS1 from MT7 111: MT_ZS1 from MT8	0: MT_ZS1 falling edge 1: MT_ZS1 rising edge
Reference MT_ZS2	Bits 4...6:	Bit 7:
	000: MT_ZS2 from MT1 001: MT_ZS2 from MT2 - 110: MT_ZS2 from MT7 111: MT_ZS2 from MT8	0: MT_ZS2 falling edge 1: MT_ZS2 rising edge
Reference MT_ZS3	Bits 8...10	Bit 11:
	000: MT_ZS3 from MT1 001: MT_ZS3 from MT2 - 110: MT_ZS3 from MT7 111: MT_ZS3 from MT8	0: MT_ZS3 falling edge 1: MT_ZS3 rising edge
Reference MT_ZS4	Bits 12...14	Bit 15
	000: MT_ZS4 from MT1 001: MT_ZS4 from MT2 - 110: MT_ZS4 from MT7 111: MT_ZS4 from MT8	0: MT_ZS4 falling edge 1: MT_ZS4 rising edge

Examples for determining the reference values of the probe evaluation in hex:

0000 = 0 hex = time stamp from probe 1 falling edge

1000 = 8 hex = time stamp from probe 1 rising edge

0001 = 1 hex = time stamp from probe 2 falling edge

1001 = 9 hex = time stamp from probe 2 rising edge

Measurement buffer

Each measuring pulse input of a Control Unit 320-2 or 310-2 has one memory for maximum 16 measured value entries (8 rising and 8 falling edges).

The measured values for rising and falling signal edges are sequentially written to the memory. If the memory is full and a new measured value is entered, all entries move down by one location and the oldest value drops out. This means that in the case of an overflow the latest 16 values are contained in the memory. When reading out an entry, the oldest value is taken from the memory. The remaining entries move down and make space for a new entry (FIFO principle).

Remarks

Other applications can also read the probe status and evaluate the probe measured values.

Example:

EPOS controls its probes axis-specifically. A control system can connect to the probe to read its data and integrate the information into the drive telegram.

4.19.1 Examples

Examples of probe evaluation

Hex values in MT_ZSB from the above example:

- 0 hex = time stamp from probe 1, falling edge
- 8 hex = time stamp from probe 1 rising edge
- 1 hex = time stamp from probe 2, falling edge
- 9 hex = time stamp from probe 2, rising edge

Example 1

MT_STW = 100H: a search is only made for rising edges for probe 1

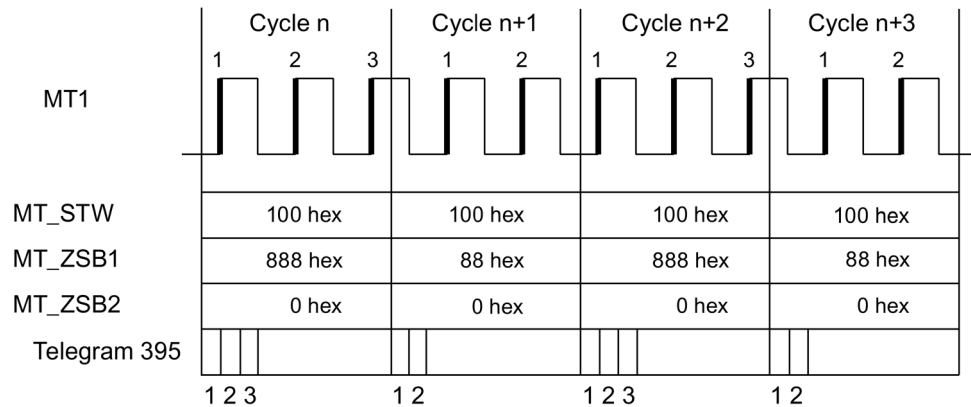

Figure 4-24 A search is made for rising edges for probe 1

In the DP cycle, all time stamps for rising edges are transferred corresponding to their sequence in time for probe 1.

Example 2

MT_STW = 101H: a search is made for rising and falling edges for probe 1.

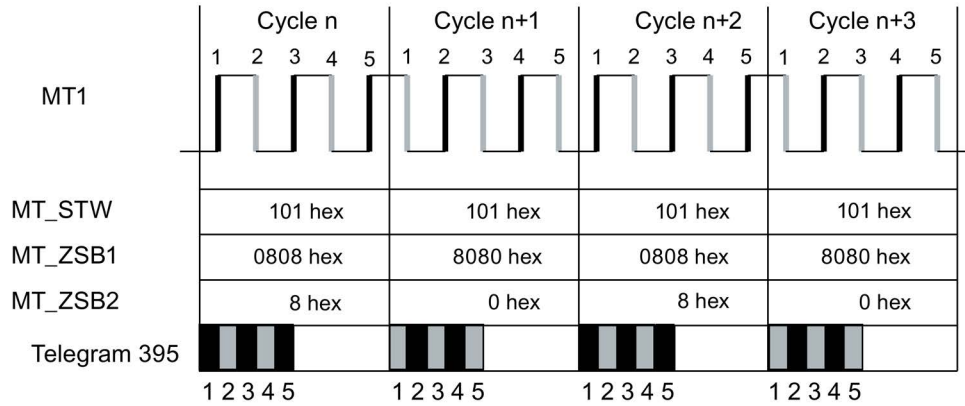

Figure 4-25 A search is made for rising and falling edges for probe 1

In the DP cycle, all time stamps for rising and falling edges are transferred corresponding to their sequence in time for probe 1.

Example 3

MT_STW = 303H: a search is made for rising and falling edges for probes 1 and 2.

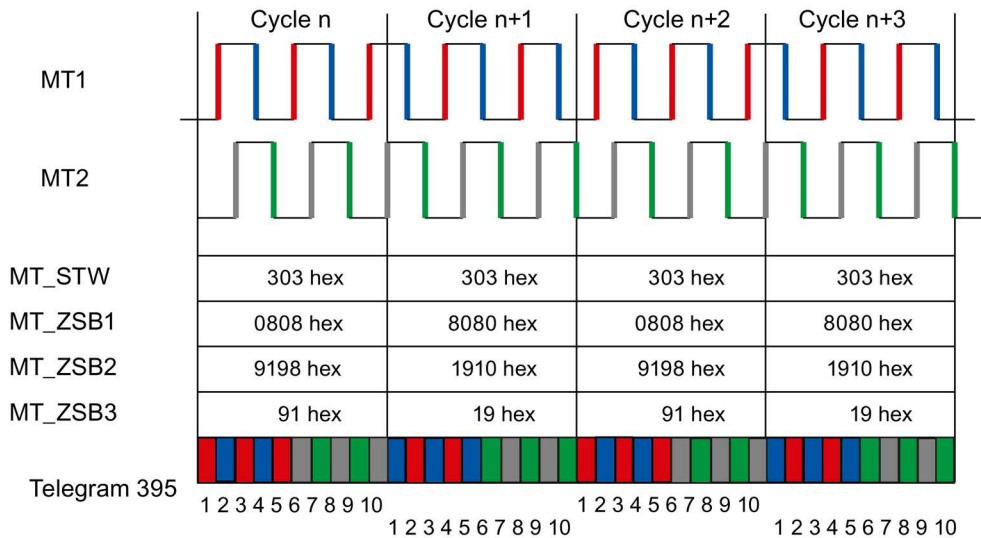

Figure 4-26 A search is made for rising and falling edges for probes 1 and 2

In the DP cycle, initially all time stamps for rising and falling edges of probe 1 are entered. Afterwards, all time stamps for rising and falling edges of probe 2.

4.19.2 Function diagrams and parameters

Function diagrams (see SINAMICS S120/S150 List Manual)

- 2423 PROFIdrive - Manufacturer-specific/free telegrams and process data
- 4740 Encoder evaluation - Probe evaluation, measured value memory, encoders 1 ... 3

Overview of important parameters (see SINAMICS S120/S150 List Manual)

- r0565[0...15] CO: Probe time stamp
- r0566[0...3] CO: Probe time stamp reference
- r0567 CO: Probe diagnostic word
- p0680[0...7] Central probe, input terminal
- p0681 BI: Central probe synchronization signal, signal source
- p0682 CI: Central probe control word signal source
- p0684 Central probe evaluation procedure
- r0685 Central probe control word display
- r0686[0...7] CO: Central probe measuring time, rising edge
- r0687[0...7] CO: Central probe measuring time, falling edge
- r0688 CO: Central probe status word display
- r0898.0...14 CO/BO: Control word, sequence control
- r0899.0...15 CO/BO: Drive object status word
- p0922 IF1 PROFIdrive PZD telegram selection
- p0925 PROFIdrive isochronous sign-of-life tolerance

Vector control

Definition

The motor connected to a vector control is simulated in a vector model based on data from the equivalent circuit diagram. The motor module is emulated as precisely as possible to obtain the best results regarding control precision and control quality.

There are 2 types of vector control:

- Vector control without encoder (Page 191) (SLVC) as frequency control
- Vector control with encoder (Page 200) as speed-torque control with speed feedback

Properties of vector control:

- Normal computing speed
- Best speed accuracy
- Best speed ripple
- Best torque accuracy
- Best torque ripple

Vector control can be used with or without a speed encoder.

Using a speed encoder

A speed encoder is required if the following criteria apply:

- High speed accuracy is required
- High dynamic response requirements
 - Better control behavior
 - Better response to disturbances
- Torque control is required in a control range greater than 1:10
- A defined and/or variable torque should be maintained for speeds below approx. 10% of the rated motor frequency (p0310).

With regard to setpoint input, vector control is subdivided into:

- Speed control
- Torque/current control (in short: torque control)

Differences with respect to vector U/f control

Compared with vector V/f control, vector control offers the following benefits:

- Stability for load and setpoint changes
- Short rise times for setpoint changes (→ better control behavior)
- Short settling times for load changes (→ better response to disturbances)
- Acceleration and braking are possible with maximum settable torque
- Motor protection due to variable torque limitation in motor and regenerative mode
- Drive and braking torque controlled independently of the speed
- Maximum breakaway torque possible at speed 0

Comparison of servo control and vector control

The table below shows a comparison between the characteristic features of servo and vector controls.

Table 5- 1 Comparison of servo control and vector control

Subject	Servo control	Vector control
Typical applications	<ul style="list-style-type: none"> • Drives with highly dynamic motion control • Drives with high speed and torque accuracy (servo synchronous motors) • Angular-locked synchronism with isochronous PROFIdrive • For use in machine tools and clocked production machines • High output frequency 	<ul style="list-style-type: none"> • Speed and torque-controlled drives with high speed and torque accuracy, particularly in operation without an encoder (sensorless operation)
Maximum number of drives that can be controlled by one Control Unit To be taken into consideration: Chapter "Rules for wiring with DRIVE-CLiQ (Page 972)" in this document below	<ul style="list-style-type: none"> • 1 infeed + 6 drives (for current controller sampling rates 125 µs or speed controller 125 µs) • 1 infeed + 3 drives (for current controller sampling rates 62.5 µs or speed controller 62.5 µs) • 1 infeed + 1 drive (for current controller sampling rates 31.25 µs or speed controller 62.5 µs) • Mixed operation, servo control with 125 µs with V/f, max.11 drives 	<ul style="list-style-type: none"> • 1 infeed + 3 drives (for current controller sampling times 250 µs or speed controller 1 ms) • 1 infeed + 6 drives (for current controller sampling times 400 µs/500 µs or speed controller 1.6 ms/2 ms) • V/f control: 1 infeed + 12 drives (for current controller sampling times 500 µs or speed controller 2000 µs) • Mixed operation, vector control with 500 µs with V/f, max.11 drives
Dynamic response	High	Medium

Subject	Servo control	Vector control
Note: Additional information on the sampling conditions is provided in subchapter "Rules regarding sampling times (Page 963)" in this manual.		
Connectable motors	<ul style="list-style-type: none"> • Synchronous servomotors • Permanent-magnet synchronous motors • Induction motors • Torque motors • Linear motors 	<ul style="list-style-type: none"> • Synchronous motors (including torque motors) • Permanent-magnet synchronous motors • Induction motors • Reluctance motors (only for V/f control) • Separately excited synchronous motors • Linear motors Note: Synchronous motors of the 1FT6, 1FK6 and 1FK7 series cannot be connected.
Position interface via PROFIdrive for higher-level motion control	Yes	Yes
Encoderless speed control	Yes, as of 10% rated motor speed, open-loop controlled operation below this	Yes (for ASM and PMSM from standstill)
Motor data identification	Yes	Yes
Speed controller tuning	Yes	Yes
V/f control	Yes	Yes (various characteristics)
Encoderless closed-loop torque control	No	Yes, as of 10% rated motor speed, open-loop controlled operation below this
Field-weakening range for induction motors	$\leq 16 \times$ field-weakening threshold speed (with encoder) $\leq 5 \times$ field-weakening threshold speed (without encoder)	$\leq 5 \times$ rated motor speed

Subject	Servo control	Vector control
Maximum output frequency with closed-loop control	<ul style="list-style-type: none"> • 2600 Hz with 31.25 μs / 16 kHz • 1300 Hz with 62.5 μs / 8 kHz • 650 Hz with 125 μs / 4 kHz • 300 Hz with 250 μs / 2 kHz <p>Note: SINAMICS S can achieve the specified values without tuning. Higher frequencies can be set under the following secondary conditions and additional tuning runs:</p> <ul style="list-style-type: none"> • Up to 3000 Hz <ul style="list-style-type: none"> – Operation without an encoder – In conjunction with controlled in-feeds • Up to 3200 Hz <ul style="list-style-type: none"> – Operation with encoder – In conjunction with controlled in-feeds • Absolute upper limit 3200 Hz <p>For frequencies > 600 Hz a license is required as a result of export regulations.</p>	<ul style="list-style-type: none"> • 300 Hz with 250 μs / 4 kHz or with 400 μs / 5 kHz • 240 Hz with 500 μs / 4 kHz <p>Note: If a higher output frequency is required, consult the specialist support from SIEMENS.</p>
<p>Note: The derating characteristics in the various manuals must be carefully observed! Max. output frequency when using dv/dt and sine-wave filters: 150 Hz</p>		
Response when operating at the thermal limit of the motor	Reduction of the current setpoint or shutdown	Reduction in the pulse frequency and / or the current setpoint or shutdown (not applicable with parallel connection / sine-wave filter)
Speed setpoint channel (ramp-function generator)	Optional (reduces the number of drives from 6 to 5 Motor Modules for current controller sampling times of 125 μ s - or speed controller sampling times of 125 μ s)	Standard
Parallel connection of power units	No	<ul style="list-style-type: none"> • Booksize: No • Chassis: Yes

5.1 Vector control without encoder (SLVC)

During operation via the "Sensorless vector control" function (SLVC), the position of the flux and actual speed must be determined using the electric motor model. The motor model is buffered by the incoming currents and voltages. At low frequencies (approx. 0 Hz), the motor model cannot determine the speed with sufficient accuracy. For this reason, in this range, the vector control can be changed over from closed-loop to open-loop control. When using passive loads, additional limitations and constraints must be taken into consideration (see Supplementary conditions for the operation of third-party motors).

Three-phase induction motor

The changeover between closed-loop/open-loop control is controlled by means of the time and frequency conditions (p1755, p1756, p1758). If the setpoint frequency at the ramp-function generator input and the actual frequency are below $p1755 \times (1 - (p1756/100\%))$ simultaneously, then the system does not wait for the time condition.

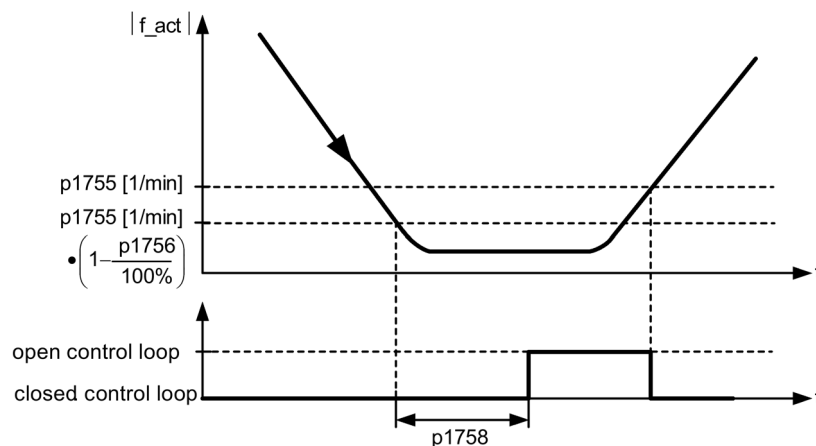

Figure 5-1 Changeover conditions for SLVC

Torque setpoint setting

In open-loop operation, the calculated actual speed value is the same as the setpoint value. For static loads (e.g. for cranes) or during acceleration, you adapt the parameters p1610 (torque setpoint static) and p1611 (additional acceleration torque) to the required maximum torque. The drive can then generate the static or dynamic load torque that occurs.

- If, for induction motors (ASM), p1610 is set to 0%, then only the magnetizing current r0331 is impressed.
If 100% is set, the rated motor current p0305 is impressed.
- If, for reluctance motors (RESM) p1610 is set to 0 %, then only the no-load magnetizing current is impressed.
If 100% is set, the rated motor current p0305 is impressed.
- For permanent-magnet synchronous motors (PMSM), for p1610 = 0%, a precontrol absolute value, derived from the additional torque r1515, remains instead of the magnetizing current of the induction motor.

To prevent stalling of the drive during acceleration, the supplementary acceleration torque p1611 can be increased or acceleration precontrol for the speed controller can be used. This avoids thermal overloading of the motor at low speeds.

If the moment of inertia of the drive is almost constant, acceleration precontrol with p1496 offers more advantages than the supplementary acceleration torque with p1611. You can determine the drive moment of inertia using the rotating measurement:
p1900 = 3 and p1960 = 1.

Encoderless vector control has the following characteristics at low frequencies:

- Closed-loop controlled operation for passive loads up to approx. 0 Hz output frequency (p0500 = 2), for p1750.2 = 1 and p1750.3 = 1.
- Start an induction motor in the closed-loop controlled mode (after the motor has been completely excited), if the speed setpoint before the ramp-function generator is greater than p1755.
- Reversing without the need to change into the open-loop controlled mode is possible, if the range of the changeover speed p1755 is passed through in a shorter time than the changeover delay time set in p1758, and the speed setpoint in front of the ramp-function generator lies outside the open-loop controlled speed range of p1755.
- In the "Torque control" mode, at low speeds, the system always changes over into the open-loop controlled mode.

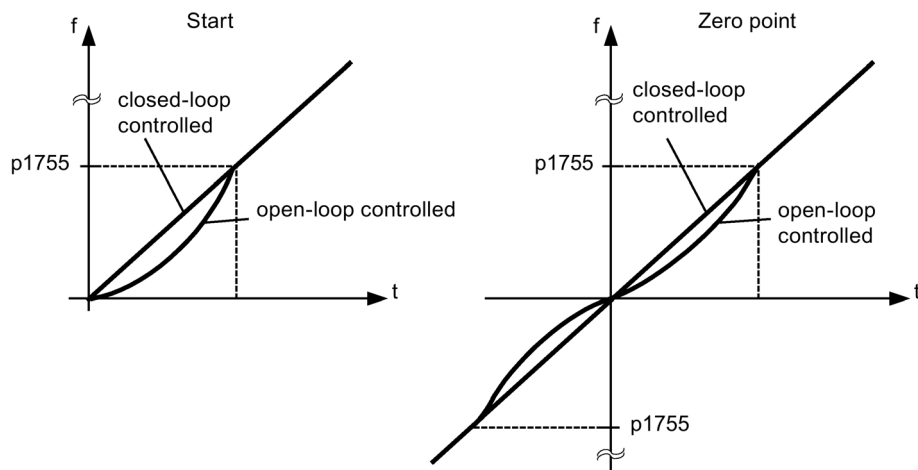

Figure 5-2 Zero crossover and when induction motors start in closed-loop or open-loop controlled operation

Closed-loop operation to approx. 0 Hz (can be set using parameter p1755) and the possibility to start or reverse at 0 Hz directly in closed-loop operation (can be set using parameter p1750) result in the following benefits:

- No changeover operation required within closed-loop control (bumpless behavior, no frequency dips, no discontinuities in the torque).
- Closed-loop speed control without encoder down to and including 0 Hz
- Passive loads down to a frequency of 0 Hz
- Steady-state closed-loop speed control down to approx. 0 Hz possible
- Higher dynamic performance when compared to open-loop controlled operation

Note

If, in the closed-loop controlled mode, start from 0 Hz or reversing takes longer than 2 s, or the time set in p1758 - then the system automatically changes over from closed-loop controlled into open-loop controlled operation.

Note

Operation in encoderless torque control only makes sense if, in the speed range below the changeover speed of the motor model (p1755), the setpoint torque is greater than the load torque. The drive must be able to follow the setpoint and the associated setpoint speed (p1499 , FBD 6030).

Passive loads

In the closed-loop controlled mode, for passive loads, induction motors can be operated under steady-state conditions down to 0 Hz (standstill) without changing over into the open-loop controlled mode.

Make the following settings for this:

1. Set p0500 = 2 (technological application = passive loads for encoderless control to $f = 0$).
2. Set p0578 = 1 (calculate technology-dependent parameters).

The following parameters are then set automatically:

- p1574 = 2 V for induction motors
- p1574 = 4 V for separately excited synchronous motors
- p1750.2 = 1, closed-loop operation down to 0 Hz for passive loads
- p1802 = 4 SVM/FLB without overcontrol
- p1803 = 106% (factory setting)

As a consequence, the "Passive load" function is automatically activated.

Note

If p0500 is parameterized when commissioning the motor, the calculation is carried out automatically via p0340 and p3900. p0578 is then set automatically.

Closed-loop control without changeover between closed-loop and open-loop speed control is restricted to applications with passive load:

A passive load only has a reactive effect on the drive torque of the driving motor at the starting point, e.g. high inertia masses, pumps, fans, centrifuges, extruders, travel drives, or horizontal conveyors.

Standstill without a holding current is possible for as long as required. Then, at standstill, only the magnetizing current is impressed in the motor.

Note

Generator operation

Steady-state generator operation at frequencies close to 0 Hz is not permissible in this operating mode.

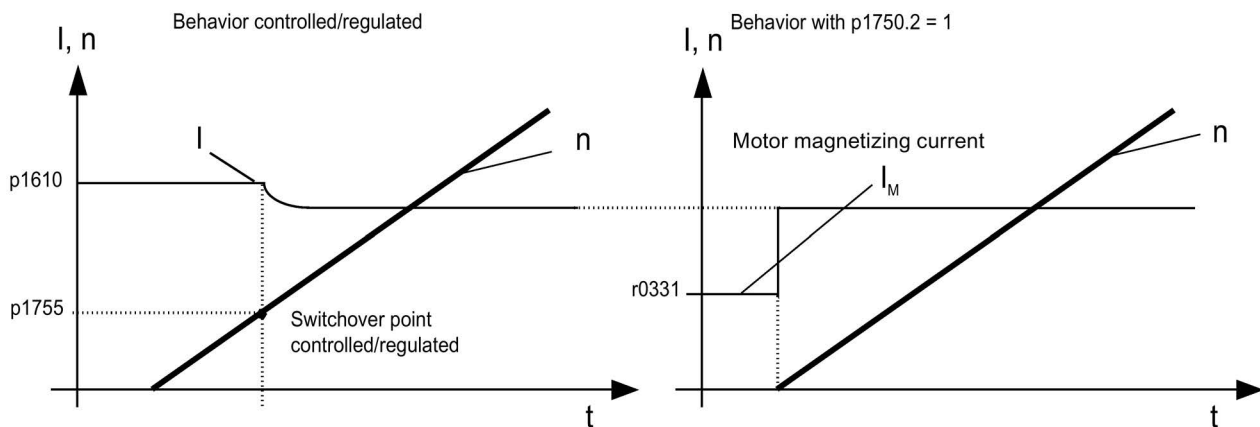

Figure 5-3 Vector control without an encoder

Blocking drives

If the load torque is higher than the torque limiting of the sensorless vector control, the drive is braked to zero speed (standstill). In order that the open-loop controlled mode is not selected after the time p1758, p1750.6 can be set to 1. Under certain circumstances the "Motor blocked delay time" (p2177) must be increased.

Note

Exception for reversing drives

It is not permissible to use this setting if the load can force the drive to reverse.

Active loads

Active loads, which can reverse the drive, e.g. hoisting gear, must be started in the open-loop speed control mode. In this case, bit p1750.6 must be set to 0 (open-loop controlled operation when the motor is blocked). The static (steady state) torque setpoint p1610 must be greater than the maximum occurring load torque.

Note

Loads that can drive the motor

For applications with high regenerative load torques at low speeds, p1750.7 can also be set to 1. As a result, the speed changeover limits of the motor model are increased and a faster changeover can be made into open-loop controlled operation.

Permanent-magnet synchronous motors

Permanent-magnet synchronous motors (PMSM) are always started and reversed in the open-loop controlled mode. The changeover speeds are set to 10% as well as 5% of the rated motor speed. Changeover is not subject to any time condition (p1758 is not evaluated). Prevailing load torques (motor or regenerative) are adapted in open-loop operation, facilitating constant-torque crossover to closed-loop operation even under high static loads. Whenever the pulses are enabled, the rotor position is identified.

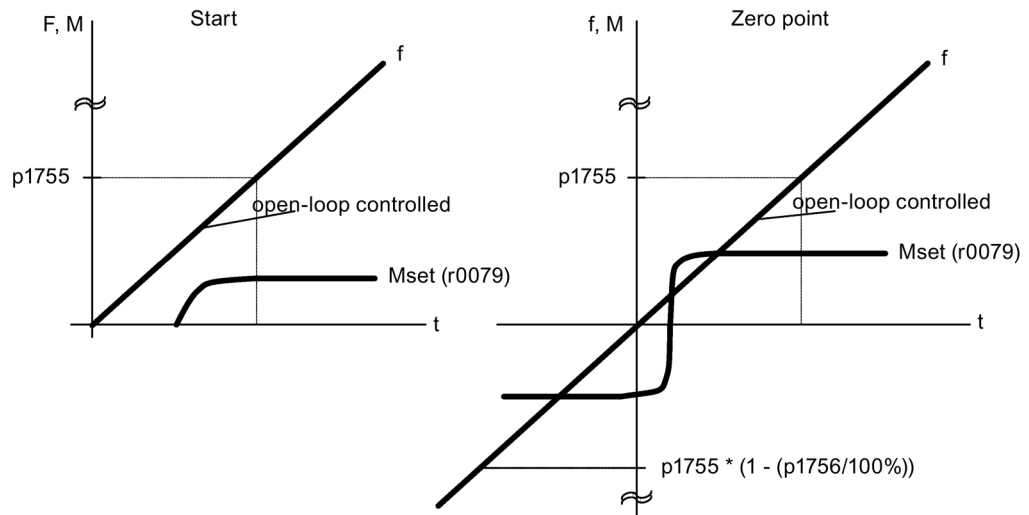

Figure 5-4 Zero point and starting in the open-loop controlled mode at low speeds

Extended method: Closed-loop controlled operation down to 0 Hz

The actual rotor position can be continuously determined down to 0 Hz (standstill). With Siemens 1FW4 and 1PH8 torque motors, the load can be maintained at standstill or, from standstill, the motor can accelerate any load up to rated torque.

When the function is activated, at low speeds, additional noise can be heard, depending on the motor design.

The procedure is suitable for motors with internal magnets.

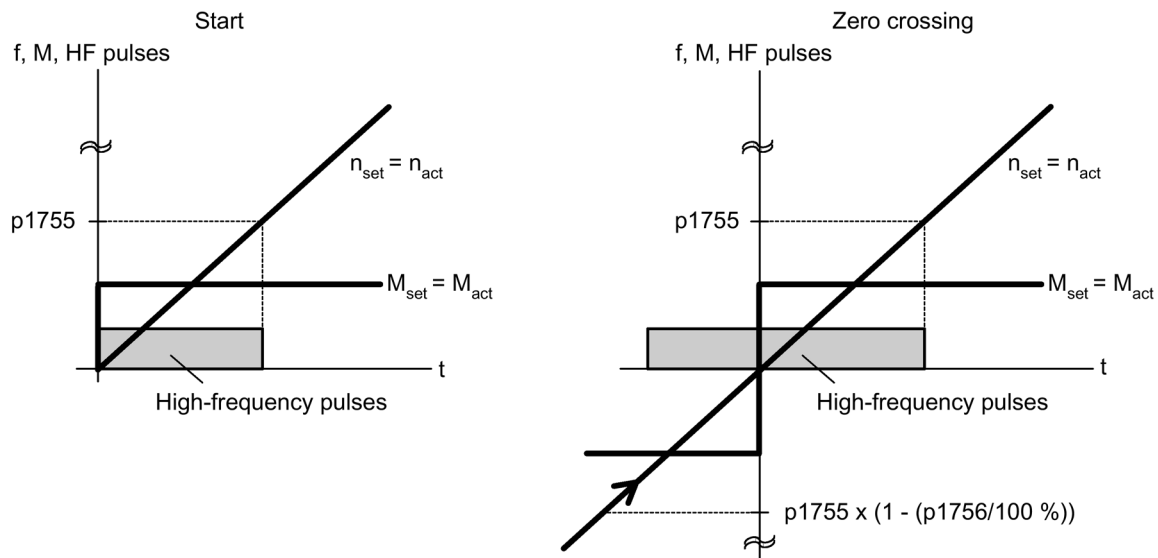

Figure 5-5 Zero point in closed-loop operation down to zero speed

Note

Only open-loop controlled operation is permitted when using a sine-wave filter.

Note

1FW4 torque motors

Siemens "1FW4" torque motors can be started from standstill and operated in the closed-loop torque controlled mode. The function is activated with parameter $p1750.5 = 1$.

Third-party motors must be checked on a case-for-case basis.

Supplementary conditions for the use of third-party motors

- The procedure is very suitable for motors with magnets within the rotor core (IPMSM - Interior Permanent Magnet Synchronous Motors).
- The ratio of stator quadrature reactance (Lsq): Stator direct-axis reactance (Lsd) must be > 1.5.
- The asymmetrical reactance ratio (Lsq:Lsd) is maintained in the motor up to a certain current; this determines the possible operating limits of the method. If the procedure should be operable up to the rated motor torque, then the reactance ratio must be retained up to the rated motor current.

The following parameter input is prerequisite for optimal performance:

- Saturation characteristic: p0362 to p0369
- Load characteristic: p0398, p0399

Commissioning sequence for closed-loop controlled operation to zero speed:

- Perform the commissioning with motor data identification at standstill.
- Enter the parameters for the saturation characteristic and the load characteristic.
- Activate closed-loop controlled operation down to zero speed via parameter p1750.5 = 1.

The following advantages are obtained by maintaining closed-loop controlled operation:

- No torque irregularities as a result of changeover operations in the closed-loop control structure
- Closed-loop speed and torque control without encoder (sensorless) up to and including 0 Hz.
- Higher dynamic performance when compared to open-loop controlled operation
- Encoderless operation of drive line-ups (e.g. in the paper industry, master-slave operation) is possible.
- Active (including hanging/suspended) loads down to zero frequency.

Note

Motor reactor, sine-wave filter, dv/dt filter

The process cannot be used with the present motor reactors, sine-wave filters and dv/dt filters.

Function diagrams (see SINAMICS S120/S150 List Manual)

- 6030 Vector control - Speed setpoint, droop
- 6730 Vector control - Interface to Motor Module (ASM, p0300 = 1)
- 6731 Vector control - interface to the Motor Module (PMSM, p0300 = 2)

Overview of important parameters (see SINAMICS S120/S150 List Manual)

- p0305[0...n] Rated motor current
- r0331[0...n] Actual motor magnetizing current / short-circuit current
- p0500 Technology application
- p1610[0...n] Torque setpoint static (without encoder)
- p1611[0...n] Supplementary acceleration torque (without encoder)
- p1750[0...n] Motor model configuration
- p1755[0...n] Motor model changeover speed encoderless operation
- p1756 Motor model changeover speed encoderless operation
- p1758[0...n] Motor model changeover delay time, closed/open-loop control
- p1802[0...n] Modulator mode
- p1803[0...n] Maximum modulation depth

5.2 Vector control with encoder

Benefits of vector control with an encoder

- The speed can be controlled right down to 0 Hz (standstill)
- Constant torque in the rated speed range
- Compared with speed control without an encoder, the dynamic response of drives with an encoder is significantly better because the speed is measured directly and integrated in the model created for the current components.
- Higher speed accuracy

Motor model change

A model change takes place between the current model and the observer model within the speed range $p1752 \times (100\% - p1753)$ and $p1752$. In the current model range (i.e at lower speeds), torque accuracy depends on whether thermal tracking of the rotor resistance is carried out correctly. In the observer-model range and at speeds of less than approx. 20% of the rated speed, torque accuracy depends primarily on whether thermal tracking of the stator resistance is carried out correctly. If the resistance of the supply cable is greater than 20 ... 30% of the total resistance, this should be entered in $p0352$ before motor data identification is carried out ($p1900/p1910$).

To deactivate thermal adaptation, set $p0620 = 0$. This may be necessary if adaptation cannot function accurately enough.

Causes for inaccuracies:

- A sensor is not used for the temperature measurement and the ambient temperatures vary greatly.
- The overtemperatures of the motor ($p0626$ to $p0628$) deviate greatly from the default settings due to the motor design.

5.3 Synchronous reluctance motors without damping cage

Synchronous-reluctance motors (RESM) without damping cage are operated with vector control (with/without encoder). The advantages of this motor type include:

- No rotor losses
- Energy efficient operation in the partial load range with reduced flux
- Fast magnetization at high load torques

Features

For this motor type, at low speeds the system changes over into open-loop speed controlled operation - and the drive system is also started in this way. The load torque requirement expected must be known for open-loop speed controlled operation, and can be parameterized using p1610 and p1611. The following preconfigurations can be made using p0500:

Settings	Application	The following parameters are automatically set for the calculation:
p0500 = 0	Standard operation (VECTOR)	p1574 = 10 V p1802 = 4 (SVM/FLB without overcontrol) p1803 = 106 %
p0500 = 1	Pumps and fans	p1574 = 2 V p1802 = 4, if r0192.0 = 0 p1803 = 106 %
p0500 = 2	Encoderless control down to f = 0 (passive loads)	p1574 = 2 V p1802 = 4 (SVM/FLB without overcontrol) p1803 = 106 %
p0500 = 4	Dynamic response in the field weakening range	p1574 = 30 V p1802 = 2 (SVM/FLB without overcontrol) p1803 = 106 %
p0500 = 6	High load moment of inertia (e.g. centrifuges)	p1574 = 10 V p1802 = 4 (SVM/FLB without overcontrol) p1803 = 106 %

When reaching the voltage limit (depending on the load and speed), the motor flux is appropriately reduced (field weakening). Depending on the torque demanded, the required motor current increases up to the available current limit. If the speed is then to increase further, in order to maintain the voltage limit, the current must be reduced to below the available current limit. In this range, the motor power available is therefore solely limited by the available voltage; for reluctance motors, as a result of the saturation attributes, is slightly below that for induction motors.

Overview of important parameters (see SINAMICS S120/S150 List Manual)

- p0500 Technological application
- p1574[0...n] Dynamic voltage reserve
- p1610[0...n] Static torque setpoint (without encoder)
- p1611[0...n] Supplementary acceleration torque (without encoder)
- p1802[0...n] Modulator mode
- p1803[0...n] Maximum modulation depth

5.4 Speed controller

5.4.1 Speed controller

Both closed-loop control procedures with and without an encoder (VC, SLVC) have the same speed controller structure which contains the following components:

- PI controller
- Speed controller precontrol
- Droop

The total of the output variables result in the torque setpoint which is reduced to the permissible magnitude by means of the torque setpoint limitation.

Function of the speed controller

The speed controller receives its setpoint (r0062) from the setpoint channel and its actual value (r0063) either directly from the speed sensor (control with sensor (VC)) or indirectly via the motor model (control without sensor (SLVC)). The system deviation is increased by the PI controller and, in conjunction with the precontrol, results in the torque setpoint.

When the load torque increases, the speed setpoint is reduced proportionately when droop is active, which means that the single drive within a group (two or more mechanically connected motors) is relieved when the torque becomes too large.

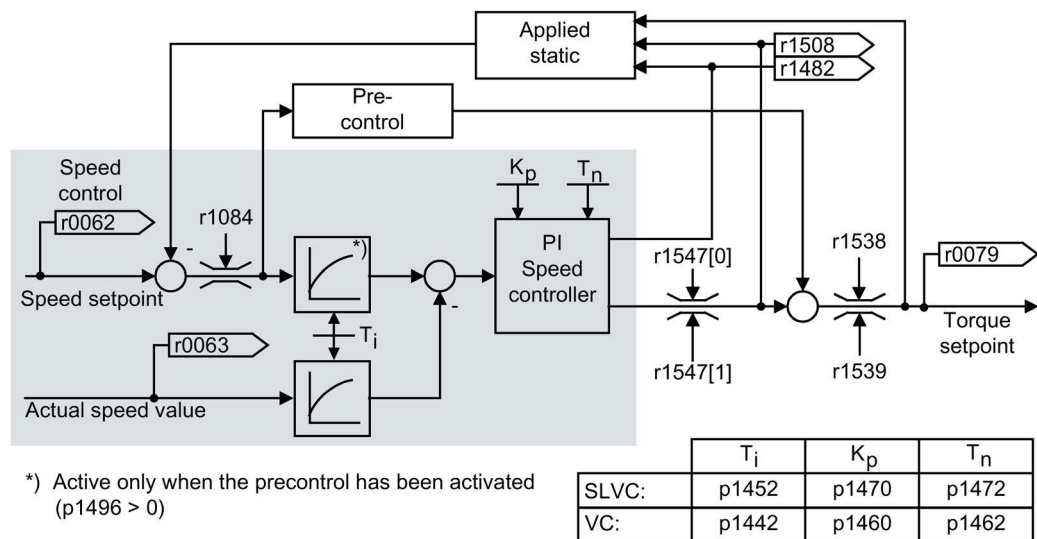

Figure 5-6 Speed controller

The optimum speed controller setting can be determined via the automatic speed controller tuning function (p1900 = 1, rotating measurement).

If the moment of inertia has been specified, the speed controller (K_p , T_n) can be calculated by means of automatic parameterization ($p0340 = 4$). The controller parameters are defined in accordance with the symmetrical optimum as follows:

$$T_n = 4 \times T_s$$

$$K_p = 0.5 \times r0345 / T_s = 2 \times r0345 / T_n$$

T_s = total of the short delay times (contains $p1442$ and $p1452$)

If vibration develops with these settings, reduce speed controller gain K_p manually. Actual speed smoothing can also be increased (standard procedure for gearless or high-frequency torsional vibration) and the controller calculation performed again because this value is also used to calculate K_p and T_n .

The following relationships apply for tuning:

- If K_p is increased, the controller becomes faster and overshoot is decreased. However, signal ripples and oscillations in the speed control loop will increase.
- If T_n is reduced, the controller also becomes faster. However, this increases the overshoot.

When setting the speed control manually, you are advised to define the possible dynamic response via K_p (and actual speed value smoothing) first, so that the integral time can subsequently be reduced as much as possible. Please note that the closed-loop control must also remain stable in the field-weakening range.

To suppress any vibrations that occur in the speed controller, it is usually only necessary to increase the smoothing time in $p1452$ for operation with an encoder or $p1442$ for operation without an encoder or reduce the controller gain.

The integral output of the speed controller can be monitored via $r1482$ and the limited controller output via $r1508$ (torque setpoint).

Note

In comparison with speed control with an encoder, the dynamic response of drives without an encoder is significantly reduced. The actual speed is derived by means of a model calculation from the converter output variables for current and voltage that have a corresponding interference level. To this end, the actual speed must be adjusted by means of filter algorithms in the software.

Speed controller response when a brake is opened

After a motor has been magnetized, "Open brake" is controlled. The value that the BICO input delivers defines the speed controller response:

- BICO input p1475 (torque setting value for the motor holding brake) supplies a value of 0:
 - The speed controller I component is immediately enabled; this means that the system can respond to a slipping load and establish a holding torque.
 - Depending on the parameter assignment, the speed setpoint remains inhibited until the brake opening time has elapsed (p1275.6 = 0) - or until the brake feedback signal is received (p1275.6 = 1).
- BICO input p1475 (torque setting value for the motor holding brake) supplies a value $\neq 0$:
 - The speed controller I component is held at the specified setting value until the "Brake open" feedback signal is received.
 - Only then are the speed controller I component and the speed setpoint enabled.

Function diagrams (see SINAMICS S120/S150 List Manual)

- 6040 Vector control - Speed controller with/without encoder

Overview of important parameters (see SINAMICS S120/S150 List Manual)

- r0062 CO: Speed setpoint after filter
- r0063[0...2] CO: Actual speed value
- p0340[0...n] Automatic calculation of motor/control parameters
- r0345[0...n] Nominal motor starting time
- p1442[0...n] Speed controller actual speed value smoothing time
- p1452[0...n] Speed controller actual speed value smoothing time (without encoder)
- p1460[0...n] Speed controller P gain adaptation speed, lower
- p1462[0...n] Speed controller integral time adaptation speed, lower
- p1470[0...n] Speed controller encoderless operation P gain
- p1472[0...n] Speed controller sensorless operation integral time
- p1475[0...n] CI: Speed controller torque setting value for motor holding brake
- p1478[0...n] CI: Speed controller integrator setting value
- r1482 CO: Speed controller I torque output
- r1508 CO: Torque setpoint before supplementary torque
- p1960 Rotating measurement selection

5.4.2 Speed controller adaptation

Fundamentals

With the speed controller adaptation, any speed controller oscillation can be suppressed.

Speed-dependent K_{p_n}/T_{n_n} adaptation is active in the factory setting. The required values are automatically calculated when commissioning and for the rotating measurement.

If, in spite of this, speed oscillations do occur, then in addition the K_{p_n} component can be tuned using the free K_{p_n} adaptation. The free K_{p_n} adaptation is activated by connecting a signal source at p1455. The factor calculated from this is multiplied by the K_{p_n} value of the speed-dependent adaptation. The range of action of the free K_{p_n} adaptation is set using parameters p1456 to p1459.

In addition using p1400.6 = 1, the T_{n_n} component of the speed-dependent adaptation can be tuned. The T_{n_n} value of the speed-dependent adaptation is divided by the factor of the free adaptation.

The K_{p_n}/T_{n_n} adaptation can be deactivated with p1400.5 = 0. As a consequence, the dynamic reduction of the speed controller is deactivated.

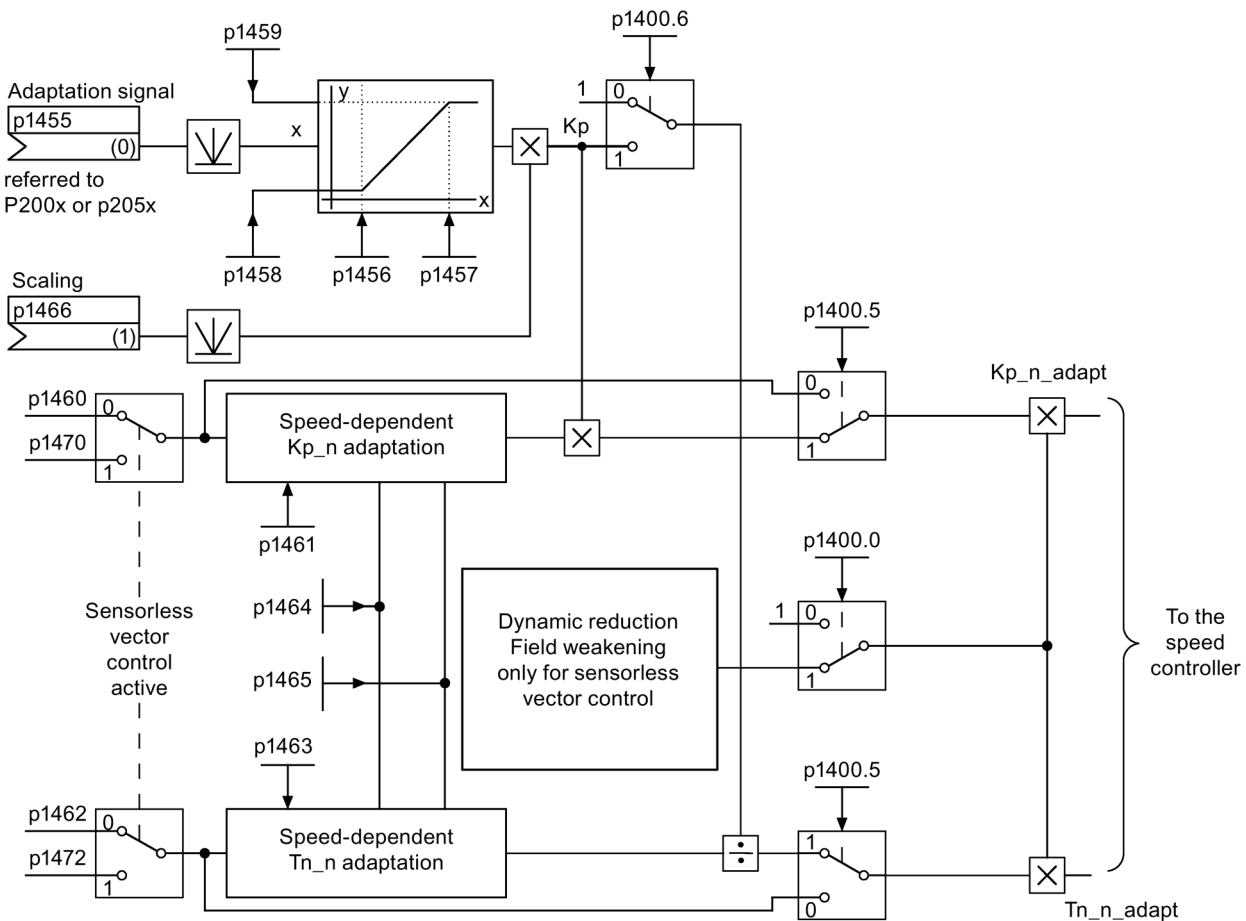
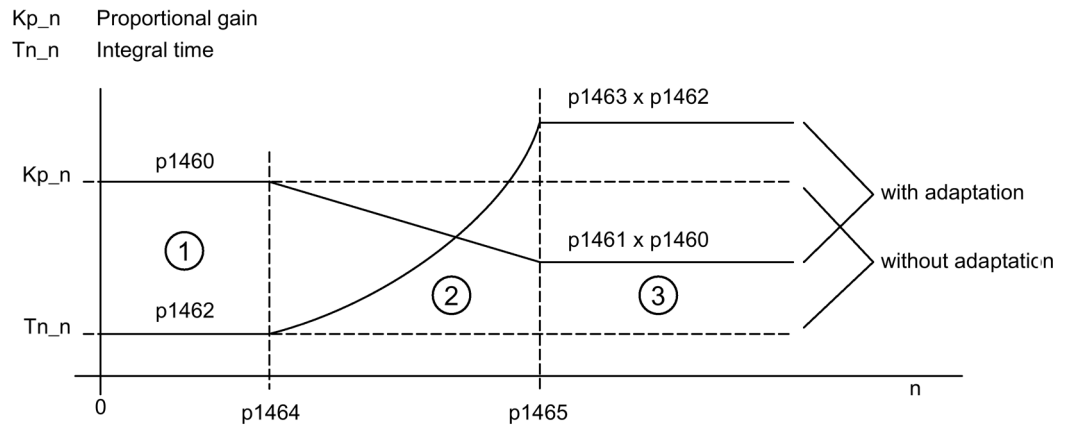

Figure 5-7 K_{p_n}/T_{n_n} adaptation

Example of speed-dependent adaptation



- ① Constant lower speed range ($n < p1464$)
- ② Adaptation range ($p1464 < n < p1465$)
- ③ Constant upper speed range ($n > p1465$)

Figure 5-8 Speed controller- K_{p_n}/T_{n_n} adaptation

For operation without encoder, a higher value is in $p1464$ than in $p1465$. As a consequence, the behavior is inverted: K_p increases with increasing speed and T_n decreases.

Special case, encoderless operation in the field-weakening range

In encoderless operation, dynamic reduction for the field-weakening range can be activated with $p1400.0 = 1$.

$K_p/T_n \sim$ flux setpoint

K_p/T_n decreases proportionally with the flux setpoint (minimum: Factor 0.25).

This dynamic reduction is activated to reduce the controller dynamic response in the field-weakening range. Up to the field-weakening range, the higher controller dynamic of the speed controller is kept.

Parameterization with STARTER

The "Speed controller" parameter screen is selected with the  icon in the toolbar of the STARTER commissioning tool.

Function diagrams (see SINAMICS S120/S150 List Manual)

- 6050 Vector control - Speed controller adaptation (K_{p_n}/T_{n_n} adaptation)

Overview of important parameters (see SINAMICS S120/S150 List Manual)

- p1400.0 Speed control configuration: Automatic Kp/Tn adaptation active
- p1400.5 Speed control configuration: Kp/Tn adaptation active
- p1400.6 Speed control configuration: Free Tn adaptation active
- p1470 Speed controller encoderless operation P gain
- p1472 Speed controller sensorless operation integral time

Free Tn_n adaptation

- p1455[0...n] CI: Speed controller P gain adaptation signal
- p1456[0...n] Speed controller P gain adaptation lower starting point
- p1457[0...n] Speed controller P gain adaptation upper starting point
- p1458[0...n] Lower adaptation factor
- p1459[0...n] Upper adaptation factor
- p1466[0...n] CI: Speed controller P gain scaling

Speed-dependent Kp_n/Tn_n adaptation

- p1460[0...n] Speed controller P gain adaptation speed, lower
- p1461[0...n] Speed controller Kp adaptation speed, upper scaling
- p1462[0...n] Speed controller integral time adaptation speed, lower
- p1463[0...n] Speed controller Tn adaptation speed, upper scaling
- p1464[0...n] Speed controller adaptation speed, lower
- p1465[0...n] Speed controller adaptation speed, upper

Dynamic response reduction field weakening (SLVC only)

- p1400.0 Speed control configuration: Automatic Kp/Tn adaptation active

5.4.3 Speed controller precontrol and reference model

Speed controller precontrol

The command behavior of the speed control loop can be improved by calculating the acceleration torque from the speed setpoint and connecting it on the line side of the speed controller. The torque setpoint "mv" is calculated as follows:

$$mv = p1496 \times J \times \frac{dn}{dt} = p1496 \times p0341 \times p0342 \times \frac{dn}{dt}$$

This torque setpoint "mv" is applied to the current controller or the current controller is precontrolled using adaptation elements directly as additive reference variable (enabled via p1496).

The motor moment of inertia p0341 is calculated directly during commissioning or when the entire set of parameters is calculated (p0340 = 1). The factor p0342 between the total moment of inertia J and the motor moment of inertia must be determined manually or by means of speed controller tuning. The acceleration is calculated from the speed difference over the time "dn/dt".

Note

When speed controller tuning is carried out, the ratio between the total moment of inertia and that of the motor (p0342) is determined and acceleration precontrol scaling (p1496) is set to 100%.

When p1400.2 = p1400.3 = 0, precontrol balancing is set automatically.

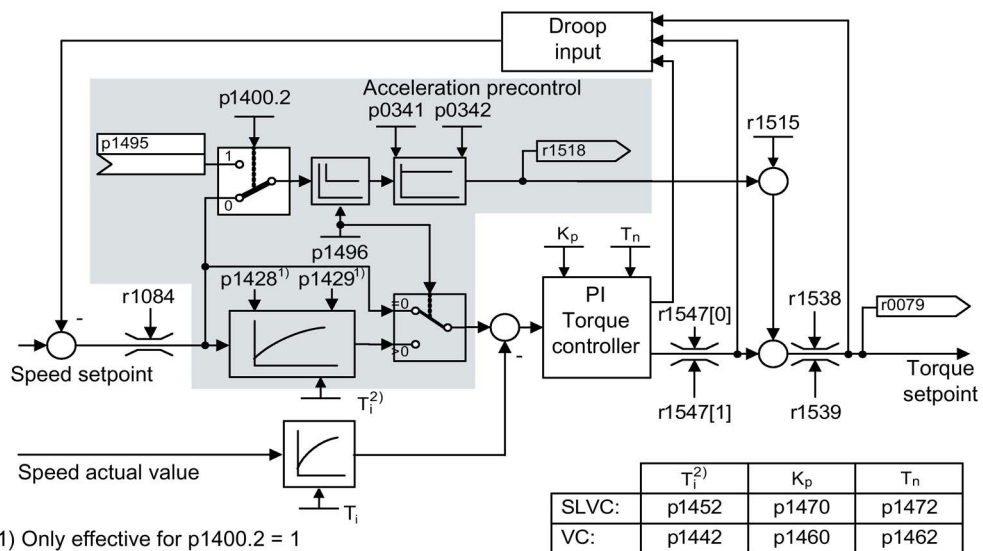

Figure 5-9 Speed controller with precontrol

If the speed controller has been correctly adjusted, it only has to compensate for disturbance variables in its own control loop, which can be achieved by means of a relatively small change to the correcting variables. Speed setpoint changes, on the other hand, are carried out without involving the speed controller and are, therefore, performed more quickly.

The effect of the precontrol variable can be adapted according to the application via the evaluation factor p1496. If p1496 = 100%, precontrol is calculated in accordance with the motor and load moment of inertia (p0341, p0342). A balancing filter is used automatically to prevent the speed controller from acting against the injected torque setpoint. The time constant of the balancing filter corresponds to the equivalent delay time of the speed control loop. Speed controller precontrol is correctly set (p1496 = 100%, calibration via p0342) when the I component of the speed controller (r1482) does not change during a ramp-up or ramp-down in the range $n > 20\% \times p0310$. Thus, precontrol allows a new speed setpoint to be approached without overshoot. (Requirement: Torque limiting does not switch in and the moment of inertia remains constant.)

If the speed controller is precontrolled through injection, the speed setpoint (r0062) is delayed with the same smoothing time (p1442 or p1452) as the actual value (r1445). This ensures that no target/actual difference (r0064) occurs at the controller input during acceleration, which would be attributable solely to the signal propagation time.

When speed precontrol is activated, the speed setpoint must be specified continuously or without a higher interference level (avoids sudden torque changes). An appropriate signal can be generated by smoothing the speed setpoint or activating the ramp-function generator rounding p1130 – p1131.

The starting time r0345 (T_{start}) is a measure for the total moment of inertia J of the machine and describes the time during which the unloaded drive can be accelerated with the rated motor torque r0333 ($M_{\text{mot, rated}}$) from standstill to the rated motor speed p0311 ($n_{\text{mot, rated}}$).

$$r0345 = T_{\text{Anlauf}} = J \times \frac{(2\pi \times n_{\text{Mot, nenn}})}{(60 \times M_{\text{Mot, nenn}})} = p0341 \times p0342 \times \frac{(2\pi \times p0311)}{(60 \times r0333)}$$

If these supplementary conditions are in line with the application, the starting time can be used as the lowest value for the ramp-up or ramp-down time.

Note

The ramp-up and ramp-down times (p1120; p1121) of the ramp-function generator in the setpoint channel should be set accordingly so that the motor speed can track the setpoint during acceleration and braking. This ensures that speed controller precontrol is functioning optimally.

The acceleration precontrol using a connector input (p1495) is activated by the parameter settings p1400.2 = 1 and p1400.3 = 0. p1428 (dead time) and p1429 (time constant) can be set for balancing purposes.

Reference model

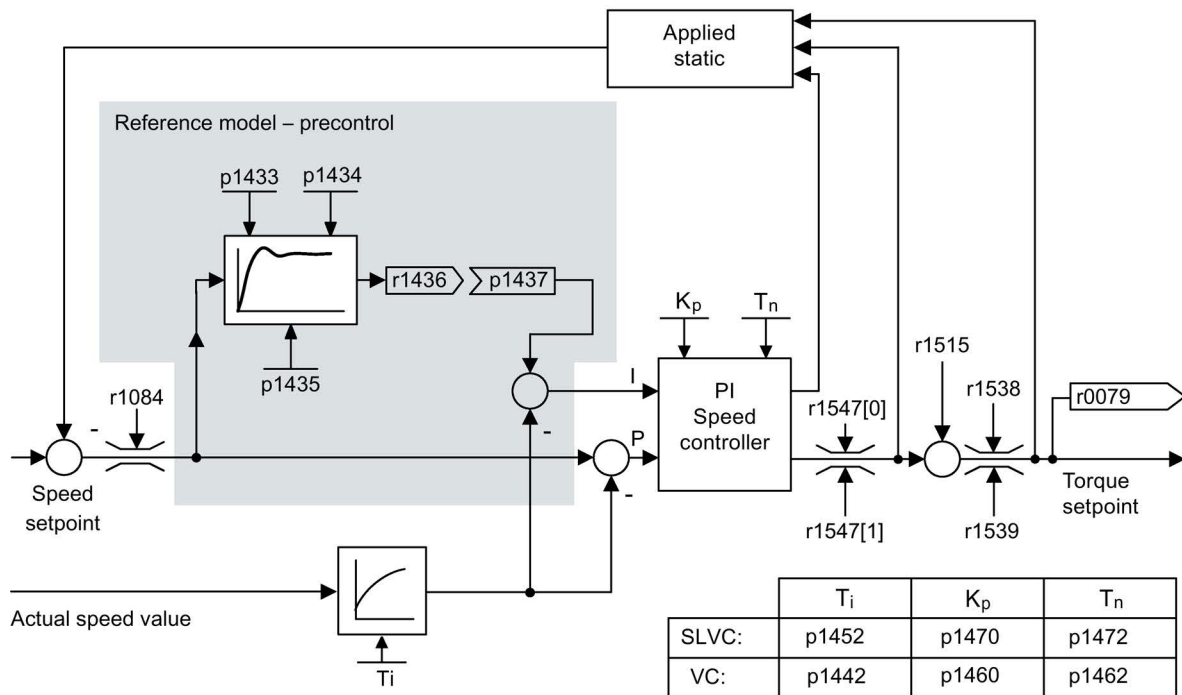

Figure 5-10 Reference model

The reference model is activated with $p1400.3 = 1$.

The reference model is used to emulate the speed control loop with a P speed controller.

The loop emulation can be set in p1433 to p1435. It is activated when p1437 is connected to the output of model r1436.

The reference model delays the setpoint-actual deviation for the integral component of the speed controller so that transient conditions can be suppressed.

The reference model can also be emulated externally and its output signal injected via p1437.

Function diagrams (see SINAMICS S120/S150 List Manual)

- 6031 Vector control - Precontrol balancing reference/acceleration model
- 6040 Vector control - Speed controller with/without encoder

Overview of important parameters (see SINAMICS S120/S150 List Manual)

- p0311[0...n] Rated motor speed
- r0333[0...n] Rated motor torque
- p0341[0...n] Motor moment of inertia
- p0342[0...n] Ratio between the total and motor moment of inertia
- r0345[0...n] Nominal motor starting time
- p1400[0...n] Speed control configuration
- p1428[0...n] Speed precontrol balancing dead time
- p1429[0...n] Speed precontrol balancing time constant
- p1496[0...n] Acceleration precontrol scaling
- r1518[0...1] CO: Acceleration torque

Reference model

- p1400[0...n] Speed control configuration
- p1433[0...n] Speed controller reference model natural frequency
- p1434[0...n] Speed controller reference model damping
- p1435[0...n] Speed controller reference model dead time
- r1436 CO: Speed controller reference model speed setpoint output
- p1437[0...n] CI: Speed controller reference model I component input

Requirements

- All coupled drives must be operated in vector control and closed-loop speed control, with or without an encoder.
- Only a single common ramp-function generator may be used for mechanically coupled drives.

Function diagrams (see SINAMICS S120/S150 List Manual)

- 6030 Vector control - Speed setpoint, droop

Overview of important parameters (see SINAMICS S120/S150 List Manual)

- r0079 CO: Torque setpoint
- r1482 CO: Speed controller I torque output
- p1488[0...n] Droop input source
- p1489[0...n] Droop feedback scaling
- r1490 CO: Droop feedback speed reduction
- p1492[0...n] BI: Droop feedback enable
- r1508 CO: Torque setpoint before supplementary torque

5.6 Open actual speed value

Via the parameter p1440 (CI: Speed controller actual speed value) is the signal source for the actual speed value of the speed controller. In the factory setting, the unsmoothed actual speed value r0063[0] is the default signal source.

Via parameter p1440, for example, a filter can be switched into the actual value channel or an external actual speed value can be fed in, according to the specific system requirements.

Parameter r1443 displays the actual speed value present at p1440.

Note

When feeding in an external actual speed value, ensure the monitoring functions continue to be derived from the motor model.

Behavior for speed control with an encoder (p1300 = 21)

A motor encoder must always be available for the speed or position signal of the motor model (e.g. evaluation via SMC, see p0400). The actual speed of the motor (r0061) and the position information for synchronous motors still come from this motor encoder and are not influenced by the setting in p1440.

Interconnection of p1440:

When interconnecting connector input p1440 with an external actual speed value, ensure the speed scaling is the same (p2000).

The external speed signal should correspond to the average speed of the motor encoder (r0061).

Behavior for speed control without an encoder (p1300 = 20)

Depending on the transmission path of the external speed signal, dead times will occur; these dead times must be taken into account in the speed controller's parameter assignment (p1470, p1472) and can lead to corresponding losses in the dynamic performance. Signal transmission times must therefore be minimized.

p1750.2 = 1 should be set so that the speed controller is also able to work at standstill (closed-loop controlled operation to zero frequency for passive loads). Otherwise, at low speeds it switches over to speed-controlled operation, so that the speed controller is switched off and the measured actual speed no longer has an influence.

Monitoring of the speed deviation between motor model and external speed

The external actual speed (r1443) is compared with the actual speed of the motor model (r2169). If the deviation is greater than the tolerance threshold set in p3236, after the switch-off delay time set in p3238 expires, fault F07937 (Drive: Speed deviation motor model to external speed) is generated and the drive switched-off corresponding to the set response (factory setting: OFF2).

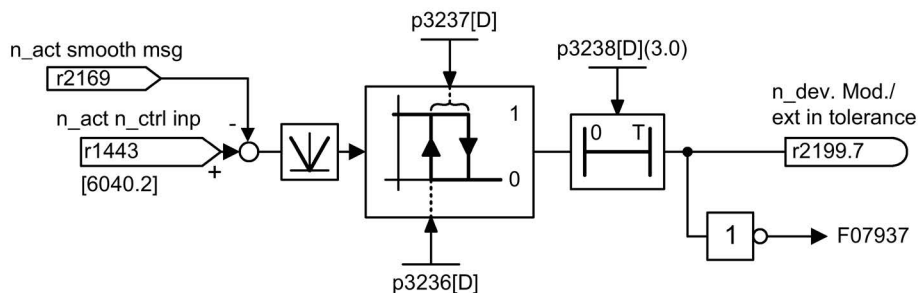

Figure 5-12 Monitoring "Speed deviation model / external in tolerance"

Function diagrams (see SINAMICS S120/S150 List Manual)

- 6040 Vector control - Speed controller with/without encoder
- 8012 Signals and monitoring function - Torque messages, motor locked/stalled

Overview of important parameters (see SINAMICS S120/S150 List Manual)

- r0063[0...2] CO: Actual speed value
- p1440[0...n] CI: Speed controller actual speed value input
- r1443 CO: Actual speed value actual speed value on actual value input
- r2169 CO: Actual speed value smoothed messages
- r2199.7 CO/BO: Status word, monitoring 3
Speed deviation model / external in tolerance
- p3236[0...n] Speed threshold 7
- p3237[0...n] Hysteresis speed 7
- p3238[0...n] OFF delay $n_act_motor_model = n_act_external$

5.7 Closed-loop torque control

With sensorless speed control SLVC (p1300 = 20) or speed control with sensor VC (p1300 = 21), a changeover can be made to torque control (slave drive) via BICO parameter p1501. A changeover cannot be made between speed and torque control if torque control is selected directly with p1300 = 22 or 23. The torque setpoint and/or supplementary setpoint can be entered using BICO parameter p1503 (CI: torque setpoint) or p1511 (CI: supplementary torque setpoint). The supplementary torque is active both with torque and speed control. This particular feature with the supplementary torque setpoint allows a precontrol torque to be applied for speed control.

Note

For safety reasons, connecting to fixed torque setpoints is currently not possible.

Regenerative energy may accumulate, and this must be either fed back into the supply system or converted into heat using a braking resistor.

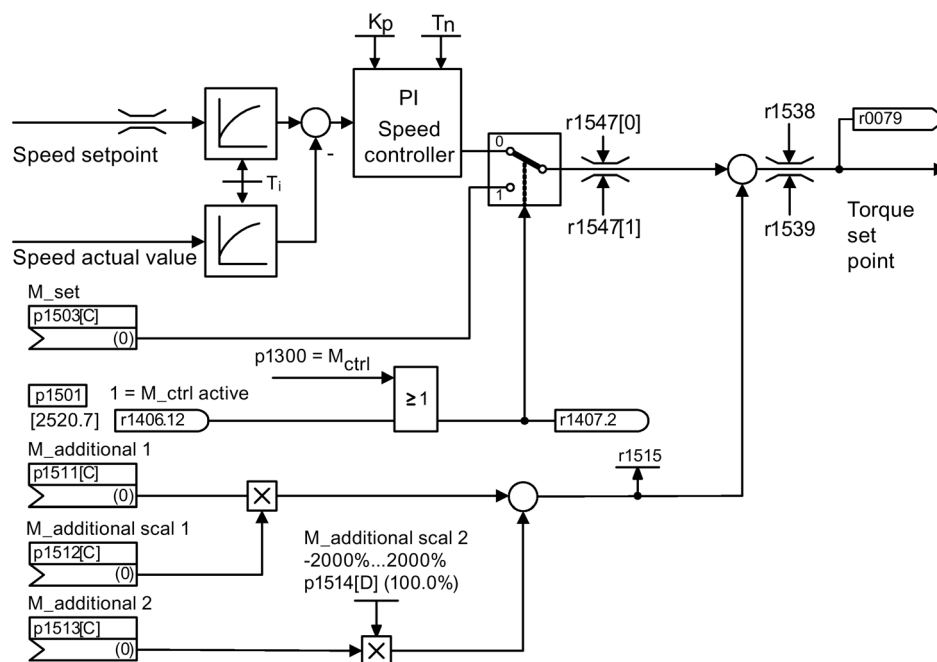

Figure 5-13 Closed-loop speed/torque control

The total of the two torque setpoints is limited in the same way as the speed control torque setpoint. Above the maximum speed (p1082), a speed limiting controller reduces the torque limits in order to prevent the drive from accelerating any further.

A "real" torque control (with self-adjusting speed) is only possible in closed-loop but not open-loop control for sensorless vector control (SLVC).

In open-loop control, the torque setpoint adjusts the setpoint speed via a ramp-function generator (integration time $\sim p1499 \times p0341 \times p0342$). For this reason, encoderless torque control at standstill is only suitable for applications that require an acceleration torque but no load torque (e.g. traction drives). This restriction does not apply to torque control with sensor.

OFF responses

- OFF1 and p1300 = 22, 23
 - Response as for OFF2
- OFF1, p1501 = "1" signal and p1300 ≠ 22, 23
 - No separate braking response; the braking response is provided by a drive that specifies the torque.
 - The pulses are suppressed when the brake application time (p1217) expires. Standstill is detected when the actual speed value is less than the speed threshold (p1226) or when the monitoring time (p1227) that started when speed setpoint ≤ speed threshold (p1226) has expired.
 - Switching-on inhibited is activated.
- OFF2
 - Immediate pulse suppression, the drive coasts to standstill.
 - The motor brake (if parameterized) is closed immediately.
 - Switching-on inhibited is activated.
- OFF3
 - Switch to speed-controlled operation
 - n_set = 0 is input immediately to brake the drive along the OFF3 deceleration ramp (p1135).
 - When standstill is detected, the motor brake (if parameterized) is closed.
 - The pulses are suppressed when the motor brake application time (p1217) has elapsed. Standstill is detected when the actual speed value is less than the speed threshold (p1226) or when the monitoring time (p1227) that started when speed setpoint ≤ speed threshold (p1226) has expired.
 - Switching-on inhibited is activated.

Function diagrams (see SINAMICS S120/S150 List Manual)

- 6060 Vector control - Torque setpoint

Overview of important parameters (see SINAMICS S120/S150 List Manual)

- p0341[0...n] Motor moment of inertia
- p0342[0...n] Ratio between the total and motor moment of inertia
- p1300[0...n] Open-loop/closed-loop control operating mode
- p1499[0...n] Accelerating for torque control, scaling
- p1501[0...n] BI: Change over between closed-loop speed/torque control
- p1503[0...n] CI: Torque setpoint
- p1511[0...n] CI: Supplementary torque 1
- p1512[0...n] CI: Supplementary torque 1 scaling
- p1513[0...n] CI: Supplementary torque 2
- p1514[0...n] Supplementary torque 2 scaling
- r1515 Supplementary torque total

5.8 Torque limiting

Description

The torque limiting value specifies the maximum permissible torque. Different limits can be parameterized for motoring and generating operation.

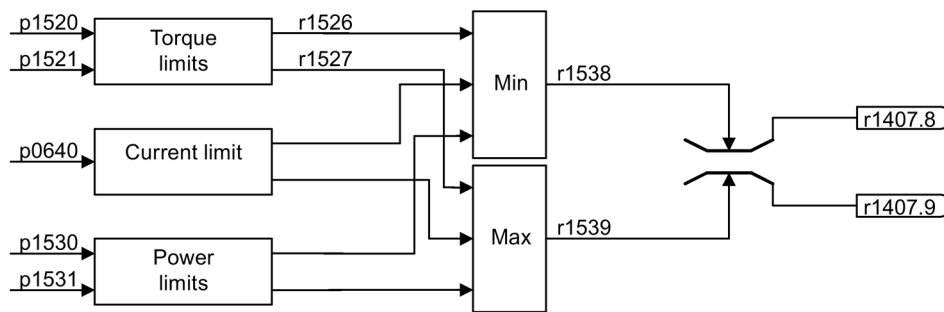

Figure 5-14 Torque limit

- p0640[0...n] Current limit
- p1520[0...n] CO: Torque limit, upper/motoring
- p1521[0...n] CO: Torque limit, lower/regenerative
- p1522[0...n] CI: Torque limit, upper/motoring
- p1523[0...n] CI: Torque limit, lower/regenerative
- p1524[0...n] CO: Torque limit, upper/motoring, scaling
- p1525[0...n] CO: Torque limit, lower/regenerative scaling
- p1530[0...n] Motor mode power limit
- p1531[0...n] Regenerative mode power limit

The currently active torque limit values are displayed in the following parameters:

- r0067 Maximum drive output current
- r1526 Torque limit, upper/motoring without offset
- r1527 Torque limit, lower/regenerative without offset

All of the following limits apply to the torque setpoint, which is present either at the speed controller output in the case of speed control, or at the torque input in the case of torque control. The minimum/maximum value of the different limits is used in each case. This minimum/maximum is cyclically calculated and displayed in the following parameters:

- r1538 CO: Upper effective torque limit
- r1539 CO: Lower effective torque limit

These cyclic values therefore limit the torque setpoint at the speed controller output / torque input or indicate the instantaneous maximum possible torque. If the torque setpoint is limited in the Motor Module, this is indicated via the following diagnostic parameters:

- r1407.8 Upper torque limit active
- r1407.9 Lower torque limit active

Function diagrams (see SINAMICS S120/S150 List Manual)

- 6060 Vector control - Torque setpoint
- 6630 Vector control - Upper/lower torque limit
- 6640 Vector control - Current/power/torque limits

5.9 Vdc control

The "Vdc control" function can be activated using the appropriate measures if an overvoltage or undervoltage is present in the DC link.

- Overvoltage in the DC link
 - Typical cause

The drive is operating in regenerative mode and is supplying too much energy to the DC link.
 - Remedy

Reduce the regenerative torque to maintain the DC link voltage within permissible limits. With the Vdc controller activated, the converter automatically partly extends the ramp-down time of a drive if the shutdown supplies too much energy to the DC link.
- Undervoltage in the DC link
 - Typical cause

Failure of the supply voltage or supply for the DC link.
 - Remedy

Specify a regenerative torque for the rotating drive to compensate the existing losses, thereby stabilizing the voltage in the DC link (kinetic buffering).

Note

During operation of the Braking Module, the following must be observed:

- You must set the threshold of the Braking Module below the V_{dc_max} threshold.
 - You must switch off the V_{dc_max} controller.
-

Properties

- V_{dc} control
 - This comprises V_{dc_max} control and V_{dc_min} control (kinetic buffering), which are independent of each other.
 - Joint PI controller. The dynamic factor is used to set V_{dc_min} and V_{dc_max} control independently of each other.
- V_{dc_max} control
 - This function can be used to control momentary regenerative load without shutdown using "overvoltage in the DC link".
 - V_{dc_max} control is only recommended with a supply without active closed-loop control for the DC link and without feedback.
- V_{dc_min} control (kinetic buffering)
 - With this function, the kinetic energy of the motor is used for buffering the DC link voltage in the event of a momentary power failure, thereby delaying the drive.

Vdc_min control

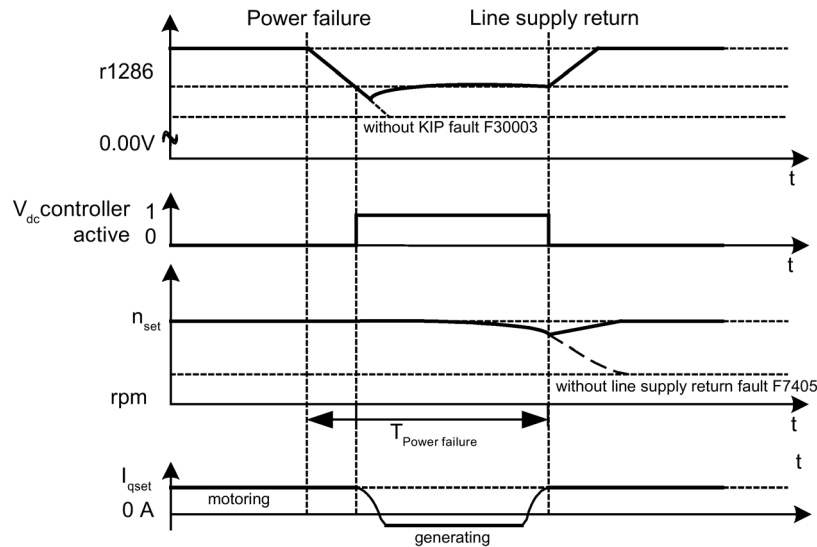

Figure 5-15 Switching V_{dc_min} control on/off (kinetic buffering)

In the event of a power failure, V_{dc_min} is activated when the V_{dc_min} switch-on level is undershot. This controls the DC link voltage and maintains it at a constant level. The motor speed is reduced.

When the power supply is restored, the DC link voltage increases again and V_{dc_min} control is deactivated again at 5% above the V_{dc_min} switch-on level. The motor continues operating normally.

If the power supply is not re-established, the motor speed continues to drop. When the threshold in p1257 is reached, this results in a response in accordance with p1256.

Once the time threshold (p1255) has elapsed without the line voltage being re-established, a fault is triggered (F07406), which can be parameterized as required (factory setting: OFF3).

The V_{dc_min} controller can be activated for a drive. Other drives can participate in supporting the DC link, by transferring to them a scaling of their speed setpoint from the controlling drive via BICO interconnection.

Note

If it is expected that the line supply will return, you must make sure that the drive lineup is not disconnected from the line supply. It could become disconnected, for example, if the line contactor drops out. The line contactor must be supplied, e.g. from an uninterruptible power supply (UPS).

Vdc_max control

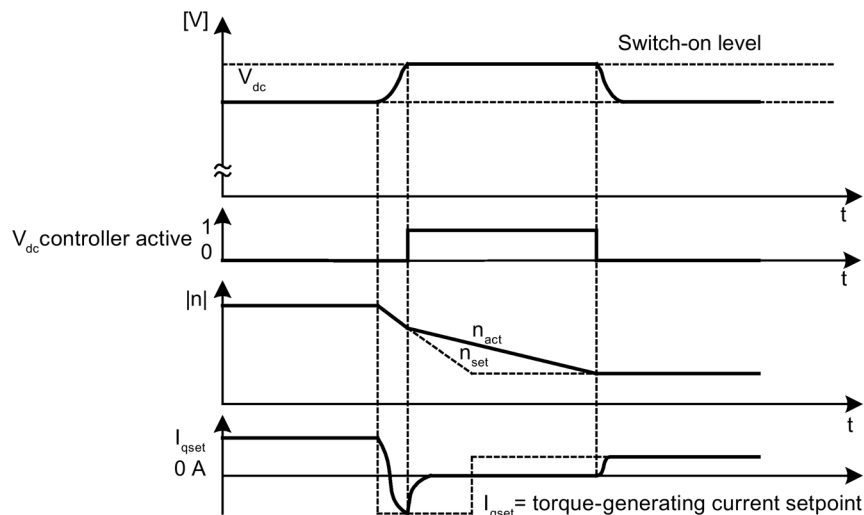

Figure 5-16 Switching the V_{dc_max} control on/off

The switch-on level for V_{dc_max} -control (r1242) is calculated as follows:

- When the function for automatically detecting the switch-on level is switched off (p1254 = 0)
 $r1242 = 1.15 \times p0210$ (device connection voltage, DC link)
- When the function for automatically detecting the switch-on level is switched on (p1254 = 1)
 $r1242 = V_{dc_max} - 50 \text{ V}$ (V_{dc_max} : Overvoltage threshold of the Motor Module)

If several Motor Modules are supplied from a non-regenerative infeed unit (e.g. a Basic Line Module), or for power failure or overload (for SLM/ALM), the V_{dc_max} control may only be activated for a Motor Module whose drive should have a high moment of inertia. For the other Motor Modules this function must be disabled or monitoring must be set. If the V_{dc_max} control is active for several Motor Modules, then for an unfavorable parameterization, the controllers can mutually influence one another negatively. The drives can become unstable, individual drives can unintentionally accelerate.

Remedial measures:

- Activating the Vdc_max control:
 - Vector control: p1240 = 1 (factory setting)
 - Servo control: p1240 = 1
 - U/f control: p1280 = 1 (factory setting)
- Inhibiting the Vdc_max control:
 - Vector control: p1240 = 0
 - Servo control: p1240 = 0 (factory setting)
 - U/f control: p1280 = 0
- Activating the Vdc_max monitoring function
 - Vector control: p1240 = 4 or 6
 - Servo control: p1240 = 4 or 6
 - U/f control: p1280 = 4 or 6

 **WARNING**

Danger to life as a result of unplanned motion of individual drives

If several Motor Modules are supplied from one infeed unit, then if the Vdc_max control is incorrectly parameterized, individual drives can accelerate in an uncontrolled fashion - which can lead to death or severe injury.

- Only activate the Vdc_max control for the Motor Module whose drive has the highest moment of inertia.
- Inhibit this function for all other Motor Modules, or set this function to monitoring only.

Function diagrams (see SINAMICS S120/S150 List Manual)

- 6220 Vector control - Vdc_max controller and Vdc_min controller

Overview of important parameters (see SINAMICS S120/S150 List Manual)

- p1240[0...n] Vdc controller or Vdc monitoring configuration
- r1242 Vdc_min controller switch-on level
- p1243[0...n] Vdc_max controller dynamic factor
- p1245[0...n] Vdc_min controller switch-on level (kinetic buffering)
- r1246 Vdc_min controller switch-on level (kinetic buffering)
- p1247[0...n] Vdc_min controller dynamic factor (kinetic buffering)
- p1250[0...n] Vdc controller proportional gain
- p1251[0...n] Vdc controller integral time
- p1252[0...n] Vdc controller rate time
- p1254 Vdc_max controller automatic ON level detection
- p1256[0...n] Vdc_min controller response (kinetic buffering)
- p1257[0...n] Vdc_min controller speed threshold
- r1258 CO: Vdc controller output

5.10 Current setpoint filter

You can parameterize the two current setpoint filters 1 and 2 connected in series as follows:

- 2nd order lowpass (PT2: -40 dB/decade)
- Bandstop
- Low-pass with reduction
- General filter 2nd order

Bandstop and low-pass with reduction are converted into the parameters of the general 2nd order filter via the STARTER commissioning tool. The phase frequency curve is shown alongside the amplitude log frequency curve. A phase shift results in a control system delay and should be kept to a minimum.

You activate the current setpoint filters with $p1656[0\dots n].0 = 1$ and $p1656[0\dots n].1 = 1$. You set the current setpoint parameters with $p1657$ to $p1666$.

As long as the parameter setting $p1699 = 1$ is active, the background calculation of the filter data is not performed, even when filter parameters are changed. Only with parameter setting $p1699 = 0$, is the calculation performed.

Examples for the current setpoint filter can be found in the description of the servo control in Section "Current setpoint filter (Page 96)".

Function diagrams (see SINAMICS S120/S150 List Manual)

- 6710 Vector control - Current setpoint filter

Overview of important parameters (see SINAMICS S120/S150 List Manual)

- | | |
|---------------------|--|
| • $p1655[0\dots 4]$ | CI: Current setpoint filter / actual speed value filter natural frequency tuning |
| • $p1656[0\dots n]$ | Current setpoint filter activation |
| • $p1657[0\dots n]$ | Current setpoint filter 1 type |
| • $p1658[0\dots n]$ | Current setpoint filter 1 denominator natural frequency |
| • $p1659[0\dots n]$ | Current setpoint filter 1 denominator damping |
| • $p1660[0\dots n]$ | Current setpoint filter 1 numerator natural frequency |
| • $p1661[0\dots n]$ | Current setpoint filter 1 numerator damping |
| • $p1662[0\dots n]$ | Current setpoint filter 2 type |
| • $p1663[0\dots n]$ | Current setpoint filter 2 denominator natural frequency |
| • $p1664[0\dots n]$ | Current setpoint filter 2 denominator damping |
| • $p1665[0\dots n]$ | Current setpoint filter 2 numerator natural frequency |
| • $p1666[0\dots n]$ | Current setpoint filter 2 numerator damping |
| • $p1699$ | Filter data acceptance |

5.11 Speed actual value filter

For vector control, an actual speed value filter can be set. You can parameterize the actual speed value filter as follows:

- 2nd order lowpass (PT2: -40 dB/decade)
- General filter 2nd order

You activate the actual speed value filter with $p1656.4 = 1$. You set the speed actual value filter parameters with $p1677$ to $p1681$.

As long as the parameter setting $p1699 = 1$ is active, the background calculation of the filter data is not performed, even when filter parameters are changed. Only with parameter setting $p1699 = 0$, is the calculation performed.

Note

For the vector control, there are two current setpoint filters and one actual speed value filter. The actual speed value filter has been allocated the number "5".

Function diagrams (see SINAMICS S120/S150 List Manual)

- 4702 Encoder evaluation - vector control, overview
- 4715 Encoder evaluation - speed actual value and pole position sensing, encoder1, n_act_filter5

Overview of important parameters (see SINAMICS S120/S150 List Manual)

- $p1655[0...4]$ CI: Current setpoint filter / actual speed value filter natural frequency tuning
- $p1656[0...n]$ Current setpoint filter / actual speed value filter activation
- $p1677[0...n]$ Actual speed value filter 5 type
- $p1678[0...n]$ Actual speed value filter 5 denominator natural frequency
- $p1679[0...n]$ Actual speed value filter 5 denominator damping
- $p1680[0...n]$ Actual speed value filter 5 numerator natural frequency
- $p1681[0...n]$ Actual speed value filter 5 numerator damping
- $p1699$ Filter data acceptance

5.12 Current controller adaptation

Current controller adaptation can be used to adapt the P gain of the current controller and the dynamic precontrol of the I_q current controller depending on the current. The current controller adaptation is directly activated with setting $p1402.2 = 1$ or deactivated with $p1402.2 = 0$. It is automatically activated with $p1959.5$ ($p1959.5 = 1$) or deactivated ($p1959.5 = 0$).

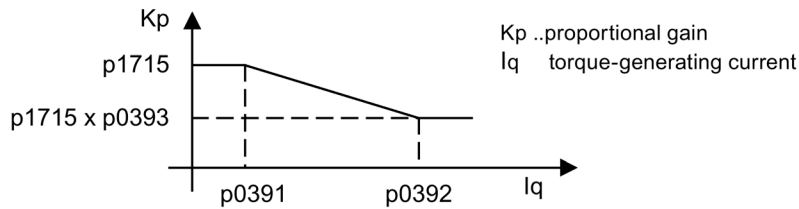

Figure 5-17 Current controller adaptation for $p0393 < 1$, with $p0391 < p0392$

When swapping the I_q interpolation points (e.g. for ASM), the current controller adaptation appears as follows:

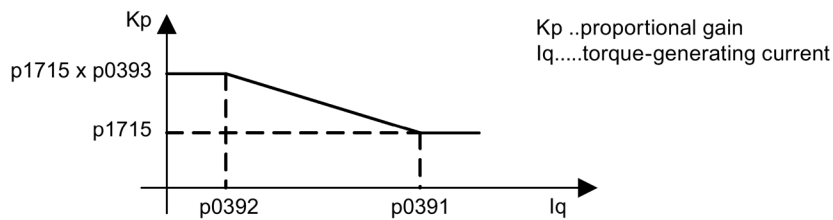

Figure 5-18 Current controller adaptation with swapped I_q interpolation points for $p0393 > 1$, with $p0392 < p0391$

Function diagrams (see SINAMICS S120/S150 List Manual)

- 6714 Vector control - I_q and I_d controller

Overview of important parameters (see SINAMICS S120/S150 List Manual)

- $p0391[0...n]$ Current controller adaptation, starting point KP
- $p0392[0...n]$ Current controller adaptation, starting point KP adapted
- $p0393[0...n]$ Current controller adaptation P gain scaling
- $p1402[0...n]$ Current control and motor model configuration
- $p1703$ I_{sq} current controller precontrol scaling
- $p1715[0...n]$ Current controller P gain
- $p1717[0...n]$ Current controller integral time
- $p1959[0...n]$ Rotating measurement configuration

5.13 Motor data identification and rotating measurement

5.13.1 Overview

There are two motor data identification options which are based on each other:

- Motor data identification (Page 234) with p1910 (standstill measurement)
For measurement of the motor equivalent circuit diagram parameters (obligatory for operation with vector control).
- Rotating measurement (Page 237) with p1960
To improve the torque accuracy and to optimize the speed control. This should be performed only after a motor data identification.

Note

If there is a motor brake, it must be open for the rotating measurement (p1215 = 2).

For synchronous motors, the motor brake must also be open for the standstill measurement so that the motor can orient itself.

The two motor data identifications can be selected more easily via p1900.

- p1900 = 2
Activates the standstill measurement (motor not rotating).
- p1900 = 1
Additionally activates the rotating measurement. p1910 is set to = 1, and p1960 is set depending on the actual control mode (p1300).
The rotating measurement can also be activated subsequently using p1900 = 3.

If a permanent-magnet synchronous motor is being used (p0300 = 2), then with p1900 > 0, the encoder adjustment (p1990 = 1) is automatically activated. The procedure used can be set in p1980.

For the selection p1900 = 1, 3, the parameter p1960 is set depending on p1300:

- p1960 = 1, when p1300 = 20 or 22 (without encoder)
- p1960 = 2, when p1300 = 21 or 23 (with encoder)

The measurements, parameterized using p1900 are started in the following sequence after the drive has been enabled:

Measurements and conclusion	After successful measurement:
Standstill measurement	Pulse inhibit activated and parameter is set to "0": p1910 = 0
Encoder adjustment	Pulse inhibit activated and parameter is set to "0": p1990 = 0
Rotating measurement	Pulse inhibit activated and parameter is set to "0": p1960 = 0
Successful completion	Pulse inhibit activated and parameter is set to "0": p1900 = 0

Note

To set the new controller setting permanently, the data must be saved in a non-volatile memory.

The measurement progress can be tracked using r0047.

Completion of the individual motor data identification runs can be read via parameters r3925 to r3928.

The motor data identification runs influence only the currently valid motor data set (MDS).

 **WARNING****Danger to life as a result of motor movement when identifying the motor data**

Motor movement caused by the motor data identification routine can result in death, severe injury or material damage.

- Ensure that nobody is in the hazardous zone - and that the mechanical system can freely move.

5.13.2 Motor data identification

Motor data identification (p1900, p1910)

The motor data identification can be activated via p1900 = 2 or p1910 = 1. It is used to determine the motor parameters (equivalent circuit diagram) at standstill.

For control engineering reasons, you are strongly advised to carry out motor data identification because the equivalent circuit diagram data and motor cable resistance can only be estimated if the data on the type plate is used. For this reason, the stator resistance is a very important for the stability of sensorless vector control or for the voltage boost in the V/f curve. Motor data identification is essential if long supply cables or third-party motors are used. When motor data identification is started, the following data is determined with p1910 on the basis of the data on the rating plate:

Table 5- 2 Determined data

Determined data for p1910 = 1	Induction motor	Permanent magnet synchronous motor	Reluctance motor
Rated magnetization current (p0320)	x	-	-
Stator resistance (p0350)	x	x	x
Rotor resistance (p0354)	x	-	-
Stator leakage inductance (p0356)	x	x	-
Stator inductance d axis (p0357)	-	x	-
Rotor leakage inductance (p0358)	x	-	-
Magnetizing inductance (p0360)	x	-	-
Drive converter valve threshold voltage (p1825)	x	x	x
Converter valve interlocking times (p1828 ... p1830)	x	x	x

Since the rating plate data contains the initialization values for identification, you must ensure that it is entered correctly and consistently (taking into account the connection type (star/delta)) so that the above data can be determined.

It is advisable to enter the motor supply cable resistance (p0352) before the standstill measurement (p1910) is performed, so that it can be subtracted from the total measured resistance when the stator resistance is calculated (p0350).

Entering the cable resistance improves the accuracy of thermal resistance adaptation, particularly when long supply cables are used. This governs behavior at low speeds, particularly during encoderless vector control.

For p1909.20 = 1 (and p0352 = 0), the supply cable resistance is set from the difference of the measured value and the default value of the automatic parameterization or the value of the data set for list motors. The supply cable resistance then normally no needs to be entered.

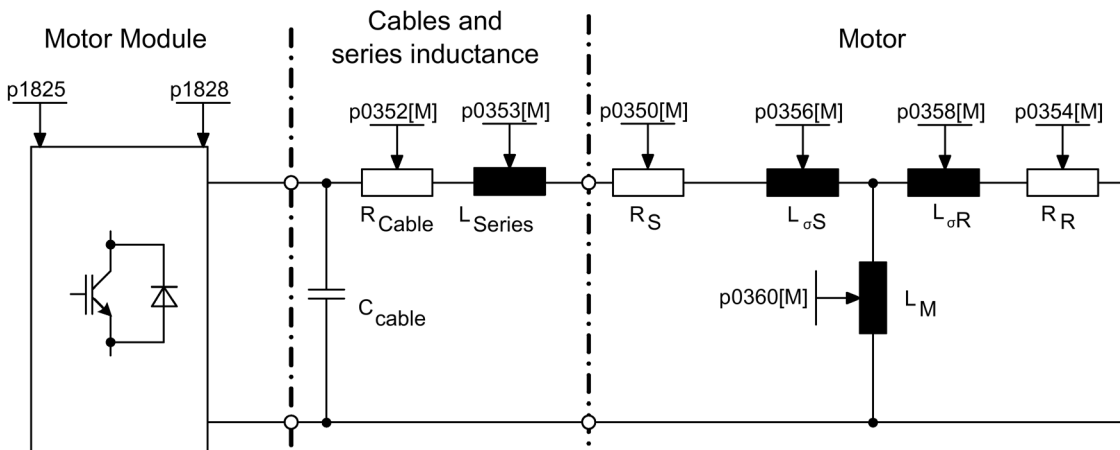

Figure 5-19 Equivalent circuit diagram for induction motor and cable

If an output filter (see p0230) or series inductance (p0353) is used, the data for this must also be entered before the standstill measurement is carried out.

The inductance value is then subtracted from the total measured value of the leakage. With sine-wave filters, only the stator resistance, valve threshold voltage, and valve interlocking time are measured.

Note

With diffusion of more than 35% to 40% of the motor nominal impedance, the dynamic response of the speed and current control is restricted to the area of the voltage limit and to field weakening mode.

Note

The standstill measurement must be carried out when the motor is cold. In p0625, enter the estimated motor ambient temperature during the measurement (for PT1000 or KTY sensor: Set p0600, p0601 and read r0035). This is the reference point for the thermal motor model and thermal R_S/R_R adaptation.

The rated magnetization current and the magnetization characteristic should, if possible, be determined during the rotating measurement (p1900 = 3) (without encoder: p1960 = 1; with encoder: p1960 = 2). The magnetization characteristic can be used to calculate the field-generating current in the field-weakening range more accurately, thereby increasing torque accuracy.

Note

In comparison with standstill measurement (p1910) for induction motors, rotating measurement (p1960) allows the rated magnetizing current and saturation characteristic to be determined much more accurately.

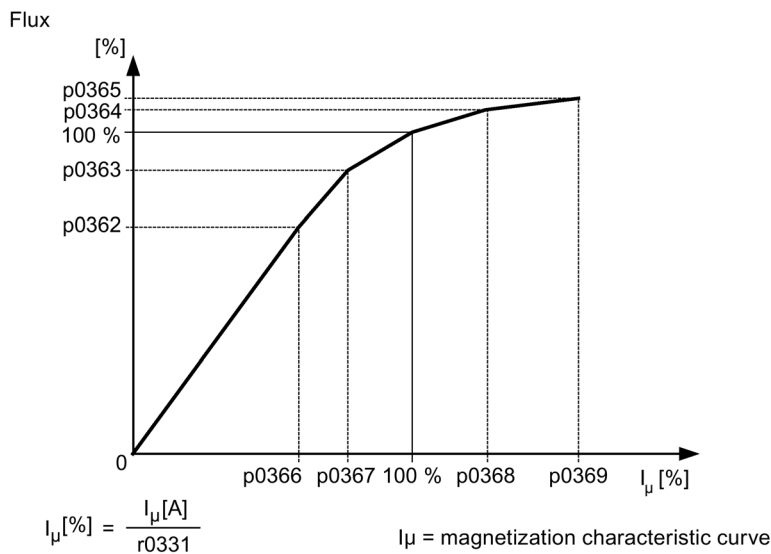

Figure 5-20 Magnetization characteristic

Note

To set the new controller setting permanently, the data must be saved in a non-volatile memory.

Note

At the end of the motor data identification, all dependent control parameters are calculated automatically (p0340 = 3)

Motor data identification procedure

1. Activate motor data identification with p1900 = 2 (or p1910 = 1).
Alarm A07991 is displayed.
2. Motor data identification starts the next time that the motor is switched on.
3. After a successful motor data identification, parameter p1900 (or p1910) is reset to "0".
If the identification was not successful, then instead, fault F07990 is output.
4. Parameter r0047 indicates the actual status of the measurement or identification.

Measurement without automatic adaptation of the control parameters (p1909.17)

p1909.17 = 1 can be used, for example, to measure the motor parameters after a motor replacement, without automatically adapting the control parameters via p0340.

5.13.3 Rotating measurement

Rotating measurement (p1900, p1960)

"Rotating measurement" can be activated via p1960 or p1900 = 3. It should be performed only after the motor data identification (p1910).

The rotating measurement contains a speed control tuning with which the drive's moment of inertia is ascertained and the speed controller is set. In addition, the saturation characteristic and rated magnetizing current of induction motors are measured and so make a significant contribution to improving the torque accuracy.

If the rotating measurement is not to be carried out using the speed set in p1965, this parameter can be changed before the measurement is started. Higher speeds are recommended.

The same applies to the speed in p1961 for which the saturation characteristic is determined and the encoder test is carried out.

The speed controller is set to the symmetrical optimum in accordance with dynamic factor p1967. p1967 must be set before the tuning run and only affects the calculation of the controller parameters.

If, during the measurement, it becomes clear that, with the specified dynamic factor, the drive cannot operate in a stable manner or the torque ripples are too large, the dynamic response is reduced automatically and the result displayed in r1968. The drive must then be checked to ensure that it is stable across the entire control range. The dynamic response might need to be reduced or the K_p_n/T_n_n adaptation for the speed controller parameterized accordingly.

Note

If the dynamic response of the speed controller is reduced excessively because of load oscillations, the oscillation test can also be deactivated (p1959.4 = 0).

When commissioning induction machines, you are advised to proceed as follows:

- Before connecting the load, a complete "rotating measurement" (p1900 = 3 or without encoder: p1960 = 1; with encoder: p1960 = 2) should be carried out. Since the induction machine is idling, you can expect highly accurate results for the saturation characteristic and the rated magnetizing current.
- When the load is connected, speed controller tuning should be repeated because the total moment of inertia has changed. This is realized by selecting parameter p1960 (without encoder: p1960 = 3; with encoder: p1960 = 4).
The saturation characteristic recording is automatically deactivated in parameter p1959 during the speed tuning run.

When permanent-magnet synchronous motors are commissioned, the speed controller should be tuned (p1900 = 3 or p1960 > 0) when the load is connected.

Rotating measurement (p1960 > 0): Sequence

The following measurements are carried out when the enable signals are set and a switch-on command is issued in accordance with the settings in p1959 and p1960.

- Encoder test

If a speed encoder is used, the direction of rotation and the pulse number are checked.

- Induction motors only:

- Measurement of the saturation characteristic (p0362 to p0369)
- Measurement of the magnetizing current (p0320) and determination of the offset voltage of the converter for offset compensation
- Measurement of the saturation of the leakage inductance, for induction motors, and setting of the current controller adaptation (p0391...p0393)

This measurement is automatically activated with 1LA1 and 1LA8 motors (p0300 = 11, 18) (see p1959.5).

- Speed controller tuning

- p1470 and p1472, when p1960 = 1 (operation without encoder)
- p1460 and p1462, when p1960 = 2 (operation with encoder)
- Setting the Kp adaptation

- Acceleration precontrol setting (p1496, p1517)

- Setting for ratio between the total moment of inertia and that of the motor (p0342)

Note

To set the new controller setting permanently, the data must be saved in a non-volatile memory.

 WARNING
--

<p>Danger to life as a result of motor movement when optimizing the speed controller</p>

<p>Motor movement caused when optimizing the speed controller can result in death, severe injury or material damage.</p>
--

- | |
|---|
| <ul style="list-style-type: none"> • Ensure that nobody is in the hazardous zone - and that the mechanical system can freely move. |
|---|

Note

If speed controller tuning is used for operation with encoder, then the closed-loop control operating mode is automatically changed over to closed-loop speed control without encoder, so that the encoder test can be carried out.

5.13.4 Shortened rotating measurement

A normal rotating measurement cannot always be performed when a load is connected. When switching the motor on for the first time, a short measurement of the moment of inertia and the measurement of the magnetizing current and the saturation characteristic can be performed with a simplified measuring procedure. The following settings are possible:

- Measurement shortened (p1959.12 = 1)
- After measurement: Direct transition to operation (p1959.13 = 1)

During the rotating measurement, the drive is not run up to the rated speed, but up to the value in p1965 related to the rated speed (p0310). In the factory setting, this is 40 %. Parameter p1965 can be adapted to the operational requirements, but must be large enough so that the machine can safely leave the open-loop controlled mode. The machine should still be operated as far as possible in no-load operation (torque < 30 % M_{rated}).

During the rotating measurement, the saving of parameters is blocked because automatic parameter adjustments made for the measurement are withdrawn again after the measurement.

Measurement shortened (p1959.12 = 1)

If you have set bit 12 in parameter p1959, a shortened rotating measurement is performed with reduced accuracy for the measurement of the moment of inertia. In this case, the magnetizing current is measured only once instead of twice. The measurement of the acceleration processes and the vibration test are not used at all.

After the end of the measurement, the drive is shut down and all the parameters modified for performing the measurement are reset to their original values.

p1959.12 does not have any effect on p1960 = 3, 4.

After measurement: Direct transition to operation (p1959.13 = 1)

In this case, the drive is not stopped at the end, but run up directly with the acceleration ramp up to the desired speed setpoint.

Do not change controller parameters during the measurement (p1959.11 = 1)

During rotating measurement, the drive automatically changes its speed controller parameters during ramp-up. This is also performed when bits 3 (recalculate speed controller parameters) and 4 (speed controller tuning) are not set. On many plants, the decoupling of the drives requires a lot of work. The loads have high moments of inertia. The controller parameters set by the drive do not always correspond to the drive application and may therefore potentially cause damage to the mechanical system.

If you have set bit 11 in parameter p1959, the recalculation of the speed controller parameters is prevented.

5.13.5 Overview of important parameters

Overview of important parameters (see SINAMICS S120/S150 List Manual)

- r0047 Motor data identification routine and speed controller optimization
- p0340 Automatic calculation of motor/control parameters
- p1300[0...n] Open-loop/closed-loop control operating mode
- p1900 Motor data identification and rotating measurement
- p1901 Test pulse evaluation configuration
- r1902 Test pulse evaluation status
- r3925[0...n] Identification complete indicator
- r3927[0...n] Motor data identification induction motor data determined
- r3928[0...n] Rotating measurement configuration

Motor data identification at standstill

- p1909[0...n] Motor data identification, control word
- p1910 Motor data identification selection

Rotating measurement

- p0391[0...n] Current controller adaptation, starting point Kp
- p0392[0...n] Current controller adaptation, starting point Kp adapted
- p0393[0...n] Current controller adaptation P gain scaling
- p1959[0...n] Rotating measurement configuration
- p1960 Rotating measurement selection
- p1961 Saturation characteristic speed to determine
- p1965 Speed_ctrl_opt speed
- p1967 Speed_ctrl_opt dynamic response factor
- r1968 Speed_ctrl_opt current dynamic response factor
- r1973 Rotating measurement encoder test pulse number determined
- p1980[0...n] PolID procedure
- p1990 Encoder adjustment, determine commutation angle offset

5.14 Efficiency optimization

The following can be achieved when tuning the efficiency using p1580:

- Lower motor losses in the partial load range
- Noise in the motor is minimized

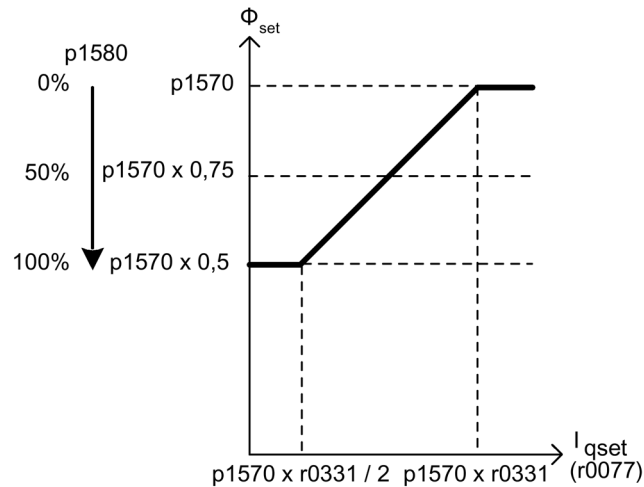

Figure 5-21 Efficiency tuning

It only makes sense to activate this function if the dynamic response requirements of the speed controller are low (e.g. pump and fan applications).

For p1580 = 100%, the flux in the motor under no-load operating conditions is reduced to half of the setpoint (reference flux) ($p1570/2$). As soon as load is connected to the drive, the setpoint (reference) flux linearly increases with the load and at approx. $r0077 = r0331 \times p1570$ reaches the setpoint set in p1570.

In the field-weakening range, the final value is reduced by the actual degree of field weakening. The smoothing time (p1582) should be set to approx. 100 to 200 ms. Flux differentiation (see also p1401.1) is automatically deactivated internally following magnetization.

Reluctance motor efficiency optimization in the partial load range

The typically high efficiency for 1FP1 reluctance motors can also be achieved in the partial load range.

To achieve this, depending on the demanded torque, the motor is operated with a loss-optimized current setpoint (MTPC: **Max-Torque-Per-Current**). This operation corresponds to a load-dependent input of the flux setpoint - and can be appropriately preconfigured when commissioning by setting p1401.3 = 1. Further, drives with reluctance motors can be optimized in the following way:

- p1401.9 = 1
Dynamically increases the flux setpoint when quickly establishing the torque.
- p1401.10 = 1
Increases the flux setpoint at low speeds and for load-dependent optimum flux characteristic (p1401.3 = 1).

Function diagrams (see SINAMICS S120/S150 List Manual)

- 6722 Vector control - Field weakening characteristic, Id setpoint (ASM, p0300 = 1)
- 6723 Vector control - Field weakening controller, flux controller (p0300 = 1)
- 6790 Vector control - flux setpoint (RESM, p0300 = 6xx)

Overview of important parameters (see SINAMICS S120/S150 List Manual)

- r0077 CO: Torque-generating current setpoint
- r0331[0...n] Actual motor magnetizing current / short-circuit current
- p1401[0...n] Flux control configuration
- p1570[0...n] CO: Flux setpoint
- p1580[0...n] Efficiency tuning

5.15 Fast magnetization for induction motors

For crane applications, frequently a frequency converter is switched alternately to different motors. After being switched to a different motor, a new data set must be loaded in the frequency converter and the motor magnetized. This can result in excessive waiting times which can be significantly reduced by means of quick magnetization.

Features

- Fast magnetization is used for induction motors in vector control.
- Fast flux build-up through injection of a field-generating current at the current limit, resulting in a significant reduction in magnetizing time.
- The "flying restart" function continues working with parameter p0346 (magnetization time).
- Magnetization is not dependent on a brake configuration (p1215) as it is with SERVO drives.

Commissioning

Parameter p1401.6 = 1 (flux control configuration) must be set to activate quick magnetization.

This setting initiates the following sequence during motor starting:

- The maximum excitation build-up current of the induction motor (in reference to the permitted rated power module current (r0207[0])) is set with parameter p0644 ("Current limit excitation build-up induction motor").
- The field-generating current setpoint jumps to the value set in p0644 or the maximum of $I_{max} = 0.9 \times r0067$ (upper limit field-generating current setpoint).
- The flux increases as fast as physically possible with the specified current.
- The flux setpoint r0083 is made to follow accordingly.
- As soon as the flux threshold value programmed in p1573 is reached (min. 10% and max. 200%, factory setting 100%), excitation is ended and the speed setpoint is enabled. The flux threshold value must not be set too low for a large load because the torque-producing current is limited during magnetization.

Note

The flux threshold value set in parameter p1573 is effective only if the actual flux during magnetization reaches the value programmed in p1573 before the time set in p0346.

- The flux is increased further until the flux setpoint in p1570 has been reached.
- The field-producing current setpoint is reduced by means of a flux controller with P gain (p1590) and the parameterized smoothing factor (p1616).

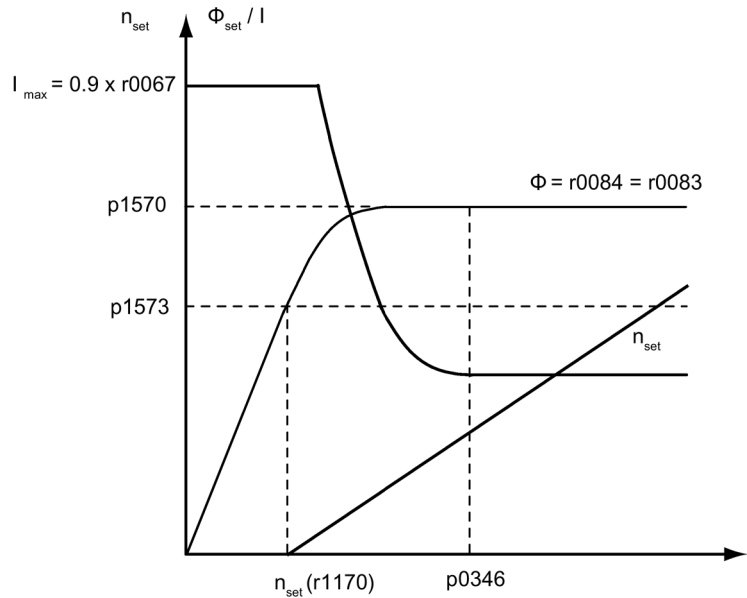

Figure 5-22 Quick magnetization characteristics

Notes

When quick magnetization is selected (p1401.6 = 1), smooth starting is deactivated internally and alarm A07416 displayed.

When the stator resistance identification function is active (see p0621 "Identification of stator resistance after restart") is active, quick magnetization is deactivated internally and alarm A07416 displayed.

The parameter (p1401.6 = 1) does not work when combined with the "flying restart" function (see p1200), i.e. flying restart is performed without quick magnetization.

Alarms and faults

Flux controller configuration

When a function controlled by parameter p1401 and p0621 is activated, the system checks whether any other incompatible function is already selected. If this is the case, alarm A07416 is displayed with the number of the parameter which is incompatible with the configuration parameter (i.e. p0621 or p1401).

As these are data-set-dependent parameters (p1401 is DDS-dependent and p0621 MDS-dependent), the number of the data set is also specified in the alarm value.

The flux control configuration (p1401) settings are inconsistent.

Fault codes:

- 1 = quick magnetization (p1401.6) and smooth starting (p1401.0)
- 2 = quick magnetization (p1401.6) and flux build-up control (p1401.2)
- 3 = quick magnetization (p1401.6) and Rs identification (stator resistance identification) after restart (p0621 = 2)

Remedy:

- For fault cause 1:
 - Deactivate smooth starting: p1401.0 = 0
 - Deactivate quick magnetization: p1401.6 = 0
- For fault cause 2:
 - Deactivate flux build-up control: p1401.2 = 0
 - Deactivate quick magnetization: p1401.6 = 0
- For fault cause 3:
 - Change Rs identification parameter settings: p0621 = 0, 1
 - Deactivate quick magnetization: p1401.6 = 0

Flux controller output limited

If the current limit p0640[D] is set very low (below the rated magnetizing current value in p0320[M]), the parameterized flux setpoint p1570 [D] might not be reached at all.

As soon as the time in p0346 (magnetization time) is exceeded, fault F07411 is output. Generally, the magnetization time is significantly longer than the flux build-up time associated with quick magnetization.

Cause:

With quick magnetization configured (p1401.6 = 1), the specified flux setpoint is not reached even though the current setpoint = 90% of maximum current.

- Motor data is incorrect.
- Motor data and motor connection type (star/delta) do not match.
- Current limit in p0640 is set too low for the motor concerned.
- Induction motor (encoderless, open-loop control) at I_{2t} limit.
- Motor Module rating is too low.

Remedy:

- Correct the motor data.
- Check the motor connection type.
- Correct the current limits (p0640, p0323).
- Reduce the load on the induction motor.
- Use a larger Motor Module if necessary.
- Check the motor supply cable.

Function diagrams (see SINAMICS S120/S150 List Manual)

- 6491 Vector control - Flux control configuration
- 6722 Vector control - Field weakening characteristic, Id setpoint (ASM, p0300 = 1)
- 6723 Vector control - Field weakening controller, flux controller (ASM, p0300 = 1)

Overview of important parameters (see SINAMICS S120/S150 List Manual)

- r0207[0...4] Rated power unit current
- p0320 [0...n] Motor rated magnetizing current / short-circuit current
- p0346 Motor excitation build-up time
- p0621[0...n] Stator resistance identification after restart
- p0640[0...n] Current limit
- p0644[0...n] Current limit excitation build-up induction motor
- p1401[0...n] Flux control configuration
- p1570[0...n] CO: Flux setpoint
- p1573[0...n] Flux threshold value magnetization
- p1590[0...n] Flux controller P gain
- p1616[0...n] Current setpoint smoothing time

5.16 Flying restart

After power ON, the "flying restart" function automatically connects a Motor Module to a motor which may already be turning. This function can be activated during operation with or without an encoder.

WARNING

Danger to life due to movement of the motor when flying restart is activated

When the "flying restart" (p1200) is activated, the drive can still be accelerated by the search current despite the fact that it is at standstill and the setpoint is "0"; this can result in death, severe injury or material damage.

- Ensure that nobody is in the hazardous zone - and that the mechanical system can freely move.

Sequence

1. The "Flying restart" function should be activated via p1200 especially for loads which may coast after power interruption.

This prevents sudden loads in the entire mechanics.

2. With an induction motor, the system waits for a demagnetization time to elapse before the search is carried out. The demagnetization time can reduce the voltage at the motor terminals. At the pulse enable, this avoids high equalizing currents due to a phase short-circuit.

An internal demagnetization time is calculated. In addition, you can define a de-excitation time via parameter p0347. The system waits for the longer of the two times to elapse.

- In operation without an encoder, a search is carried out initially for the current speed. The search starts at the maximum speed plus 25%. A Voltage Sensing Module (VSM) is required for permanent-magnet synchronous motors (for additional information, see SINAMICS S120 Control Units Manual).
- When operated with an encoder (actual speed value is sensed), the search phase is eliminated.

3. For an induction or reluctance motor, immediately after the speed has been determined, magnetization starts (p0346).
4. The current speed setpoint in the ramp-function generator is then set to the current actual speed value.

The ramp-up to the final speed setpoint starts with this value.

Application example

After a power failure, a fan drive can be quickly reconnected to the running fan motor by means of the "flying restart" function.

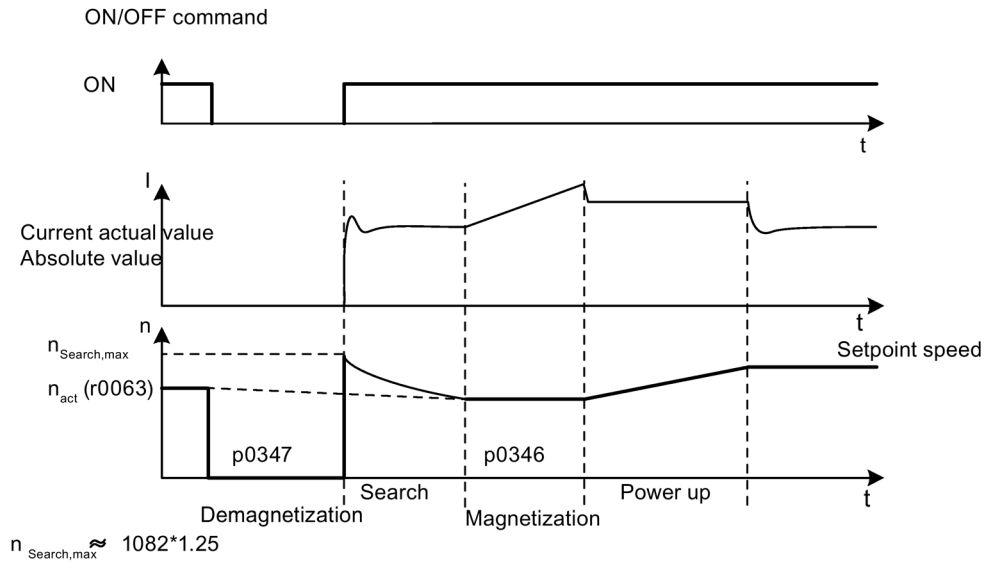

Figure 5-23 Flying restart, example of induction motor without encoder

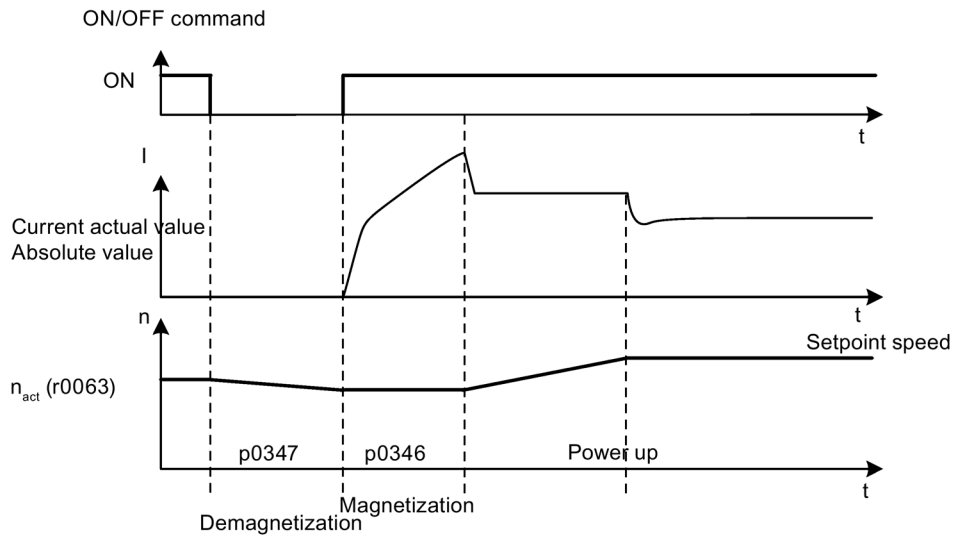

Figure 5-24 Flying restart, example of induction motor with encoder

Flying restart in encoderless operation for long cables

As a rule, it is important to consider the cable resistance. The cable resistance is required for calculation of the thermal motor model.

1. Enter the cable resistance in parameter p0352 before you perform motor data identification.
2. For an induction motor, set parameter p1203[0...n] to at least 300%.

This operation can take a little longer than for the factory setting (100%).

The setting is not required for a reluctance motor.

Note

Use a trace recording to check and optimize the flying restart function. If necessary, optimize the settings of parameters p1202 and p1203.

5.16.1 Fast flying restart

For encoderless operation (vector, U/f linear and parabolic), there is a "fast flying restart". The "fast flying restart" function is only possible for induction motors.

Fast flying restart without voltage measurement

For fast flying restart without voltage measurement, the starting frequency is set to zero. The model settles within approximately 200 ms on its own when the parameterization is correct. This fast flying restart works only under the following conditions:

- At a current controller cycle time of 250 μ s or 400 μ s (without filter and long cables)
- Up to 4x the rated speed for vector control
- Up to the rated speed for V/f control

The settings for fast flying restart can be made in the expert list.

1. To switch flying restart to "fast flying restart", make the following setting: "p1780.11 = 1".

The normal flying restart had the parameter setting "p1780.11 = 0". For operation with encoder, settings of this bit are ignored because fast flying restart is not possible in this case.

2. Activate the fast flying restart as with the normal flying restart via parameter p1200.
3. Perform a standstill measurement (p1900 = 2) for the correct parameterization of the voltage model for both vector and U/f control to determine the power resistance.

The critical parameters are the stator resistance (p0350) and the stator leakage inductance (p0356).

The following status bits indicate the characteristic of the flying restart:

- For U/f control: r1204.14.
- For vector control: r1205.16 or r1205.17.

Note

Parameter p1203 has no effect on the fast flying restart. Parameter p1202 (flying restart detection current) can be used to tune the fast flying restart.

Note

Detection current must not become too small

If the drive is operated well into the field weakening or with filters or long cables, the detection current may become too small with the fast flying restart (F07330).

In this case, set the detection current (p1202) to values > 30%.

Fast flying restart with voltage acquisition

The time for the connection to a rotating induction motor can be shortened when the terminal voltage of the motor is measured. This requires that a VSM module is connected (see Chapter "Voltage Sensing Module (Page 255)").

1. Select the voltage measurement for the fast flying restart: p0247.5 = 1.
2. Activate the flying restart: p1200 > 0.

The following status bits indicate the characteristic of the flying restart:

- For U/f control: r1204.15
- For vector control: r1205.18, r1205.19, r1205.20

Note

If the measured voltage amplitude undershoots the 1% limit of the converter rated voltage, the flying restart with voltage measurement is deactivated and the rotating frequency sought.

5.16.2 Flying restart for a reluctance motor

With encoderless control of a reluctance motor, using the "Flying restart" function, the position and speed of the rotor can be determined with almost no delay.

To increase the quality of the function, a motor data identification routine (p1900, stationary measurement) must be carried out. The motor properties are measured so that the flying restart function can optimally determine the speed and the position.

 WARNING
Danger to life due to movement of the motor when flying restart is activated
When the "flying restart" (p1200) is activated, the drive can still be accelerated by the search current despite the fact that it is at standstill and the setpoint is "0"; this can result in death, severe injury or material damage.
<ul style="list-style-type: none">• Ensure that nobody is in the hazardous zone - and that the mechanical system can freely move.

Sequence

1. Activate the "Flying restart" function using p1200 especially for loads which may coast down after the power is interrupted.

This avoids the complete mechanical system from being subject to sudden loads.

2. Contrary to an induction motor, for a reluctance motor, the system does not wait a specific demagnetization time (see. "Flying restart for an induction motor (Page 247)"). Flying restart can be activated for the rotating machine immediately after switching off.

3. For a reluctance motor, immediately after the speed has been determined, magnetization starts (p0346).
4. The actual speed setpoint is then set in the ramp-function generator to the speed actual value.
Ramp-up (acceleration) to the final speed setpoint starts from this value.
Bit r1205.21 indicates whether flying restart is active.
5. The search current and the search speed can be set using parameters p1202 and p1203 to optimize the flying restart.

Note

If the search current is changed (p1202), then a stationary measurement must be carried out to accept the change. After changing the parameter, the measurement is configured (p1909.22 = 1) so that it is as short as possible. The bit is only reset if a motor data identification routine has been carried out.

5.16.3 Messages and parameters

Overview of important faults (see SINAMICS S120/S150 List Manual)

- F07330 Flying restart: Detection current measured too low
- F07331 Flying restart: Function not supported

Overview of important parameters (see SINAMICS S120/S150 List Manual)

- p0247 Voltage measurement configuration
- p0352[0...n] Cable resistance
- p1082[0...n] Maximum speed
- p1200[0...n] Flying restart operating mode
- p1202[0...n] Flying restart detection current
- p1203[0...n] Flying restart search rate factor
- r1204.0...15 CO/BO: Flying restart, V/f control status
- r1205.0...21 CO/BO: Flying restart, vector control status
- p1780.11 Motor model adaptation configuration
Fast flying restart with voltage model for induction machines
- p1900 Motor data identification and rotating measurement
- p1909[0...n] Motor data identification control word

5.17 Synchronization

Description

You can synchronize a motor with the line supply using the "Synchronization" function and an existing voltage sensing module VSM10 (to measure the line voltage). The connection to the line supply or the required contactor control can be realized using the existing bypass function or a higher-level control system.

Use of the bypass function supports temporary (for example, for maintenance work without plant standstill) or permanent operation of the motor on the line supply.

Synchronization is activated with parameter p3800. A VSM10 which is assigned to a drive (via DRIVE-CLiQ), measures the line supply voltage.

Requirement

- Drive in the vector control mode with Voltage Sensing Module (VSM10)
- Induction motor without encoder
- Vector control

Features

- Connector inputs for the actual voltage sensing of the motor via VSM10 (p3661, r3662)
- Setting a phase difference (p3809)
- Can be activated by parameter (p3802)

Function diagrams (see SINAMICS S120/S150 List Manual)

- 7020 Technology functions - Synchronizing

Overview of important parameters (see SINAMICS S120/S150 List Manual)

- p3800[0...n] Sync-line-drive activation
- p3801[0...n] Sync-line-drive drive object number
- p3802[0...n] BI: Sync-line-drive enable
- r3803.0 CO/BO: Sync-line-drive control word
- r3804 CO: Sync-line-drive target frequency
- r3805 CO: Sync-line-drive frequency difference
- p3806[0...n] Sync-line-drive frequency difference threshold value
- r3808 CO: Sync-line-drive phase difference
- p3809[0...n] Sync-line-drive phase setpoint value
- p3811[0...n] Sync-line-drive frequency limitation
- r3812 CO: Sync-line-drive correction frequency
- p3813[0...n] Sync-line-drive phase synchronism threshold value
- r3814 CO: Sync-line-drive voltage difference
- p3815[0...n] Sync-line-drive voltage difference threshold value
- r3819.0...7 CO/BO: Sync-line-drive status word

5.18 Voltage Sensing Module

The Voltage Sensing Module (VSM) is required in the Vector Control and in V/f control for following functions:

- Synchronizing

Using the "synchronizing" function, the system is synchronized to a line supply. For example, after synchronization the motor is directly switched over to the line supply (bypass). Another application is the temporary operation of the motor on the line supply to allow the converter to be maintained without shutting down the plant or system.

For p3800 = 1, the voltage is sensed using a VSM, which is assigned to the line phases and a Motor Module (via DRIVE-CLiQ).

- Flying restart

After power ON, the "flying restart" function automatically connects a Motor Module to a motor which may already be turning. In operation without an encoder, a search is carried out initially for the motor speed.

A Voltage Sensing Module (VSM) is required for this function for permanent-magnet synchronous motors (see SINAMICS S120 Control Units Manual).

A VSM can be used for induction motors in order to reduce the duration of the search (see Chapter "Fast flying restart (Page 250)").

If only one VSM exists, it is used to acquire the motor voltages when "synchronize" is deactivated (p3800 = 0).

Topology view

The VSM is used on the encoder side for SINAMICS S120 drives. The VSM is only used at the VECTOR drive object in sensorless operating modes. The VSM is integrated into the topology at the position of the motor encoder.

VSM commissioning using STARTER

The VSM for the VECTOR drive object is selected in STARTER using the drive wizard. As the VSM is not assigned to the encoder data sets (EDS), it cannot be selected on the encoder side. The component number of the VSM from the current topology must be entered in parameter p0151[0...1]. This parameter assigns the VSM data set to a VSM evaluation routine. With parameter p0155[0...n] "Activate/deactivate Voltage Sensing Module", it is possible to activate or deactivate the VSM explicitly as a topology component.

VSM parameters are independent of the SINAMICS data set model. A maximum of two VSMs are permitted for each VECTOR drive object.

Note

Using two VSMs

If 2 VSMs are connected to one Motor Module, the 1st VSM (p0151[0]) is used to measure the line voltage (p3801). The 2nd VSM is used to measure the motor voltage (p1200).

Identification via LED and firmware version

VSM identification via LED is activated via parameter p0154.

When p0154 = 1, the LED RDY on the relevant VSM flashes green/orange or red/orange at a frequency of 2 Hz.

The firmware version of the VSM can be displayed using parameter p0158[0,1] on the VECTOR drive object.

Function diagrams (see SINAMICS S120/S150 List Manual)

- 7020 Technology functions - Synchronizing
- 9880 Voltage Sensing Module (VSM) - Analog inputs (AI 0 ... AI 3)
- 9886 Voltage Sensing Module (VSM) - Temperature evaluation

Overview of the important parameters (see SINAMICS S120/S150 List Manual)

- p0151[0...n] Voltage Sensing Module component number
- p0155[0...n] Activate/deactivate Voltage Sensing Module
- p0158[0...n] Voltage Sensing Module firmware version
- p3800[0...n] Sync-line-drive activation
- p3801[0...n] Sync-line-drive drive object number

5.19 Simulation mode

Simulation mode allows you to simulate the drive without a connected motor and without the DC-link voltage. In this case, it should be noted that the simulation mode can only be activated under an actual DC-link voltage of 40 V. If the voltage is higher, simulation mode is reset and fault message F07826 is output.

With the simulation mode, you can test the communication with a higher-level controller. If the drive is also to return actual values, note that it must be switched over to encoderless operation during simulation mode. This means that large parts of the SINAMICS software (e.g. software channel, sequence control, communications, technology function, etc.) can be tested in advance without requiring a motor.

For units with outputs of > 75 W it is recommended to test the activation of the power semiconductors after repairs. To do so, a DC voltage < 40 V is applied to the DC link, and the possible pulse patterns must be tested by the control software.

The simulation mode can be activated via $p1272 = 1$.

Note

Simulation mode cannot be activated without a power unit. A power unit must be connected via DRIVE-CLiQ.

Requirements

The following requirements must be satisfied to do this:

- Initial commissioning must be complete (default: Standard induction motors).
- The DC-link voltage must be < 40 V (observe the tolerance of the DC-link voltage sensing).

Features

- Automatic deactivation with a DC-link voltage greater than 40 V (measurement tolerance ± 4 V) with fault F07826 and immediate pulse inhibit (OFF2)
- Can be activated via parameter p1272
- Deactivation of line contactor activation during simulation mode
- Activation of power semiconductor with low DC-link voltage and with motor (for test purposes).
- Power unit and closed-loop control can be simulated without a connected motor.

5.20 Redundancy mode power units

Redundancy mode can be used so that operation can be continued in spite of the failure of one power unit connected in parallel.

Note

Despite this redundancy circuit, the entire plant may shut down when defects develop in a power unit (feedback effects due to absence of electrical isolation).

In order that the failed power unit can be replaced, DRIVE-CLiQ cables must be connected in a star-type configuration - it may be necessary to use a DRIVE-CLiQ HUB Module (DMC20 or DME20). The failed power unit must be deactivated via p0125 or via the binector input p0895, before it is removed. When a replacement power unit has been installed it must be activated accordingly.

Requirements

- Only possible for identical chassis power units connected in parallel
- Maximum number of parallel power units is 4
- Parallel connection of power units with suitable power reserves
- DRIVE-CLiQ star topology (possibly a DMC20 or a DME20, see SINAMICS S120 Control Units Manual)
- Motor with one single-winding system (p7003 = 0)
- No Safe Torque Off (STO)

Features

- Redundancy for up to 4 chassis power units
- Power unit can be deactivated via parameter (p0125)
- Power unit can be deactivated via binector input (p0895)

Overview of important parameters (see SINAMICS S120/S150 List Manual)

- p0125[0...n] Activate/deactivate power unit component
- r0126[0...n] Power unit components active/inactive
- p0895[0...n] BI: Activate/deactivate power unit component
- p7003 Par_circuit winding system

5.21 Bypass

5.21.1 Overview

The bypass function controls two contactors via digital outputs of the drive converter and evaluates the feedback signals of the contactors via digital inputs (e.g. via TM31). This circuit allows the motor to be operated using the converter or directly on the supply line. The contactors are activated by the converter. The feedback signals for the contactor positions have to be returned to the converter.

The bypass circuit can be implemented in two ways:

- Without synchronizing the motor to the line supply and
- Synchronizing the motor to the line supply.

The following applies to all bypass versions:

- The bypass switch is also shut down (the motor coasts down) when one of the "OFF2" or "OFF3" control word signals is canceled. When "OFF1" is withdrawn, the motor remains connected to the line supply.
- Exception:
When required, the bypass switch can be interlocked by a higher-level controller so that the drive converter can be completely powered-down (i.e. including the control electronics) while the motor is operated from the line supply. The contactor interlocking should be implemented on the plant/system side.
- When the drive is started up again after POWER ON, the status of the bypass contactors is evaluated. After powering up, the converter can thereby change straight into "Ready to start and bypass" status. This is only possible if the bypass is activated via a control signal, the control signal (p1266) is still present once the system has been ramped up, and the automatic restart function (p1210 = 4) is active.

The bypass is automatically started again when restarting. To accelerate the motor to the setpoint speed and/or to synchronize to the line supply, the pulses are enabled, possibly with the motor already rotating. In this case, we recommend that the "Flying restart" function (p1200 = 1) is activated in order to avoid high current peaks.

- Changing the converter into "Ready to start and bypass" status after powering up, is of a higher priority than switching back on automatically.
- Monitoring of the motor temperatures using temperature sensors is active while the converter is in one of two states "Ready to start and bypass" or "Ready for operation and bypass".
- The two motor contactors must be designed for switching under load.

Note

The examples contained in the following descriptions are only basic circuits designed to explain the basic function. The dimensions of specific circuit configurations (contactors, protective equipment) must be calculated for specific systems.

NOTICE

Damage to the device by changing the phase sequence without adapting the hardware

Changing the phase sequence or the direction of rotation using p1820/p1821, without physically adapting the phase cables results in incorrect synchronization. In the worst-case scenario, this can mechanically damage the plant or system.

- Adapt the phase cables to the modified phase sequence or the modified direction of rotation.

Requirement

The bypass function is only possible for encoderless closed-loop speed control (p1300 = 20) or V/f control (p1300 = 0...19) and when an induction motor is used.

Features

- Available for vector control
- Available for induction motors without encoder

Commissioning the bypass function

The bypass function is part of the function module "technology controller" that can be activated when using the commissioning wizard. Parameter r0108.16 indicates whether it has been activated.

5.21.2 Bypass with synchronization with overlap

Description

The "Bypass synchronized with overlap" is used for drives with low inertia. These are drives in which the speed would decrease very quickly when contactor K1 is opened.

When "bypass with synchronization with overlap (p1260 = 1)" is activated, the motor is transferred, synchronized to the line supply and is also retrieved again. During the changeover, the two contactors K1 and K2 are simultaneously closed for a time (phase lock synchronization).

A voltage sensing module VSM10 is required for this type of bypass which measures the line supply voltage required for the drive to be synchronized.

A reactor is used to de-couple the drive converter from the line supply - the uk value for the reactor is 10% +/- 2%.

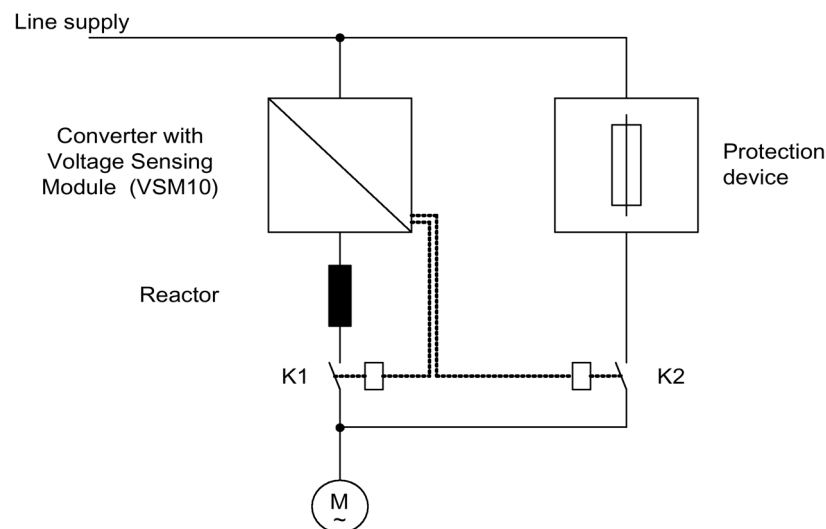

Figure 5-25 Circuit example: Bypass with synchronization with overlap

Activation

The bypass function with synchronization with overlap (p1260 = 1) can only be activated using a control signal. Activation using a speed threshold is not possible.

Parameter assignment

The following parameters must be set after the bypass function with synchronization with overlap (p1260 = 1) has been activated.

Table 5-3 Parameter setting for bypass function with synchronization with overlap

Parameter	Description
r1261.0 =	Control signal for contactor K1
r1261.1 =	Control signal for contactor K2
p1266 =	Setting the control signal
P1269[0] =	Signal source to provide the feedback signal of contactor K1
P1269[1] =	Signal source for contactor K2 feedback
p3800 = 1	Synchronization is activated.
p3802 = r1261.2	Synchronizer activation is triggered by the bypass function.

Transfer sequence

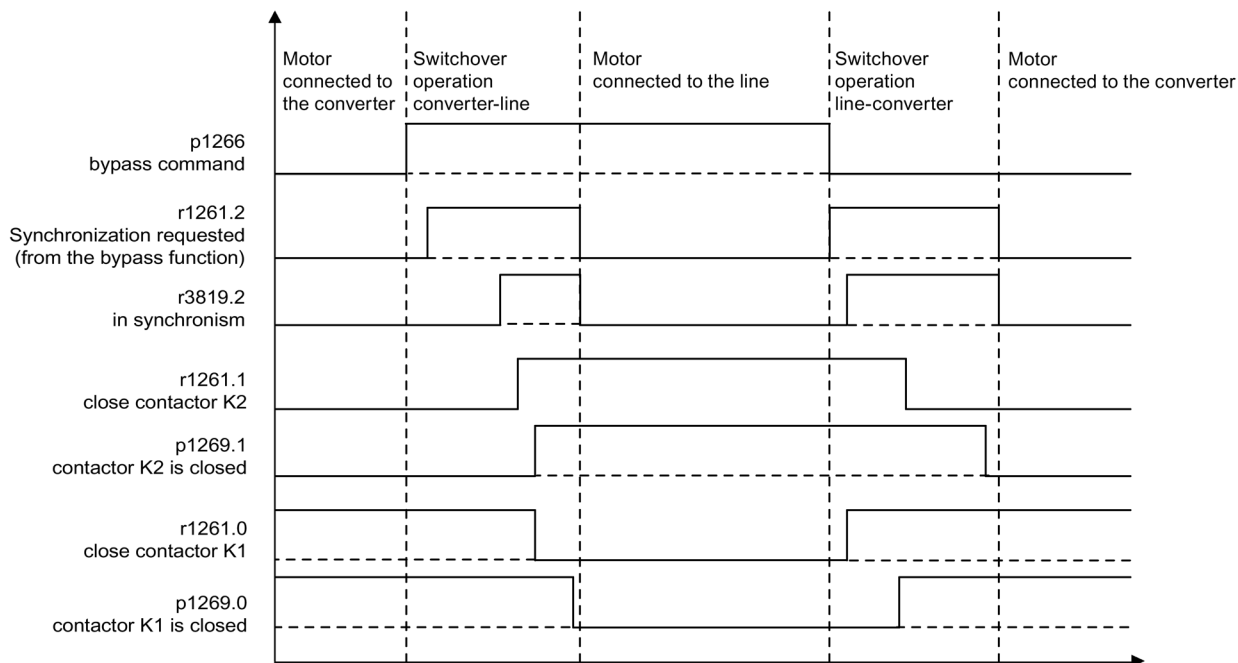

Figure 5-26 Signal diagram, bypass with synchronization with overlap

The motor is transferred to the line supply (the drive converter controls contactors K1 and K2):

- The initial state is as follows: Contactor K1 is closed, contactor K2 is open and the motor is fed from the drive converter.
- The control bit "bypass command" (p1266) is set (e.g. from the higher-level automation).
- The bypass function sets the control word bit "synchronizing" (r1261.2).

- Since the bit is set while the converter is running, the "Transfer motor to supply" synchronization process is started.
- After the motor has been synchronized to the line frequency, line voltage and line phase, the synchronizing algorithm reports this status (r3819.2).
- The bypass mechanism evaluates this signal and closes contactor K2 (r1261.1 = 1). The signal is internally evaluated - BICO wiring is not required.
- After contactor K2 has signaled back the "closed" state (r1269[1] = 1), contactor K1 is opened and the drive converter inhibits the pulses. The drive converter is in the "hot standby" state.
- If the on command is withdrawn in this phase, the drive converter changes into the basic standby state. If the appropriate contactors are being used, the drive converter is isolated from the line supply and the DC link is discharged.

Retrieving the motor from supply mode functions the same but in reverse:

At the start of the process, contactor K2 is closed and contactor K1 is opened.

- The "Command bypass" control bit is canceled (e.g. by the higher-level automation).
- The bypass function sets the control word bit "synchronizing".
- Pulses are enabled. Since "Synchronize" is set before "Pulse enable", the converter interprets this as a command to retrieve a motor from the supply and to take it over.
- After the motor has been synchronized to the line frequency, line voltage and line phase, the synchronizing algorithm reports this status.
- The bypass mechanism evaluates this signal and closes contactor K1. The signal is internally evaluated - BICO wiring is not required.
- Once contactor K1 has reported "closed" status, contactor K2 is opened and the motor returns to operation on the drive.

5.21.3 Bypass with synchronization without overlap

Description

When "bypass with synchronization without overlap (p1260 = 2)" is activated, contactor K2 to be closed is only closed when contactor K1 has opened (anticipatory type synchronization).

During this time, the motor is not connected to the line supply so that its speed is determined by the load and the friction. This type of bypass is therefore suitable for drives with high inertia (see the note below).

Synchronization setpoint p3809 is used to correct a phase rotation in the signal sensing of the voltage actual values (p3809 = -180°...179,90°). Further, using this parameter, the setpoint angle of the motor voltage can be advanced in a range up to a maximum of 20°el (= maximum value, p3813), in order to compensate for a friction/load-dependent speed decrease during the bypass switchover.

The phase position of the motor voltage before synchronization can be set using p3809 to enable an "advance start" before the line supply to which synchronization should be carried out. As a result of the motor braking in the short time in which both contactors are open,

when closing contactor K2, now a phase and frequency difference of approximately zero must be obtained. If, when switching over, the angular difference would be $> 20^\circ\text{el}$, then current surges be expected that cannot be neglected. This is the reason that synchronism is only reached if the angular difference is $\leq p3813$ (maximum of 20°el).

Compensating a speed decrease using p3809 only makes sense if the motor is evenly loaded during the switchover period. For instance, for conveyor belts, depending on the process environment, the load can change during the bypass sequence.

If, during the switchover process, the angular difference is more than 20°el - or if the load for each bypass operation differs, then the "Bypass with synchronization with overlap (Page 261)" mode must be used.

A voltage sensing module VSM10 is required for this type of bypass which measures the line supply voltage required for the drive to be synchronized.

For the function to run correctly, the moment of inertia of the drive and the load must be sufficient.

Note

A sufficiently high moment of inertia is characterized by a change in the motor speed during opening of the contactors K1 and K2 that is approximately equal to the rated slip.

Further, it must be ensured that at the switchover instant, the motor is not significantly braked as a result of external effects (e.g. friction).

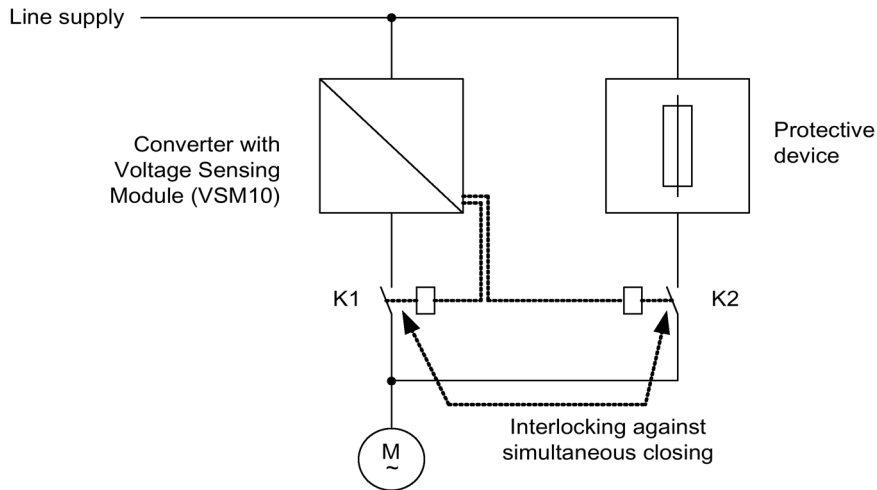

Figure 5-27 Circuit example, bypass with synchronization without overlap

Activation

The bypass function with synchronization without overlap (p1260 = 2) can only be activated using a control signal. Activation using a speed threshold is not possible.

Parameter assignment

The following parameters must be set after the bypass function with synchronization without overlap (p1260 = 2) has been activated.

Table 5- 4 Parameter settings for bypass function with synchronization without overlap

Parameter	Description
r1261.0 =	Control signal for contactor K1
r1261.1 =	Control signal for contactor K2
p1266 =	Setting the control signal
P1269[0] =	Signal source to provide the feedback signal of contactor K1
P1269[1] =	Signal source for contactor K2 feedback
p3800 = 1	Synchronization is activated.
p3802 = r1261.2	Synchronizer activation is triggered by the bypass function.
p3809 =	Setting of the phase setpoint for synchronizing the drive to the line supply

5.21.4 Bypass without synchronization

Description

When the motor is transferred to the line supply, contactor K1 is opened (after the drive converter pulses have been inhibited); the system then waits for the motor de-excitation time and then contactor K2 is closed so that the motor is directly connected to the line supply.

Because the motor is not synchronized when it is connected to the line supply an equalization current flows. This must be taken into account when designing the protective equipment (refer to the diagram, "Circuit example, bypass without synchronization"). This is why this type of bypass is only suitable for drives with a low power rating.

When the converter retrieves the motor from the line supply, initially contactor K2 is opened, and after the excitation time has expired, contactor K1 is closed. The drive converter then connects to the rotating motor and the motor is fed from the drive converter.

A voltage sensing module VSM10 is not required for this type of bypass.

In this case, contactor K2 must be designed/selected to be able to switch inductive loads.

Contactor K1 and K2 must be interlocked so that they cannot simultaneously close.

The "flying restart" function must be activated (p1200).

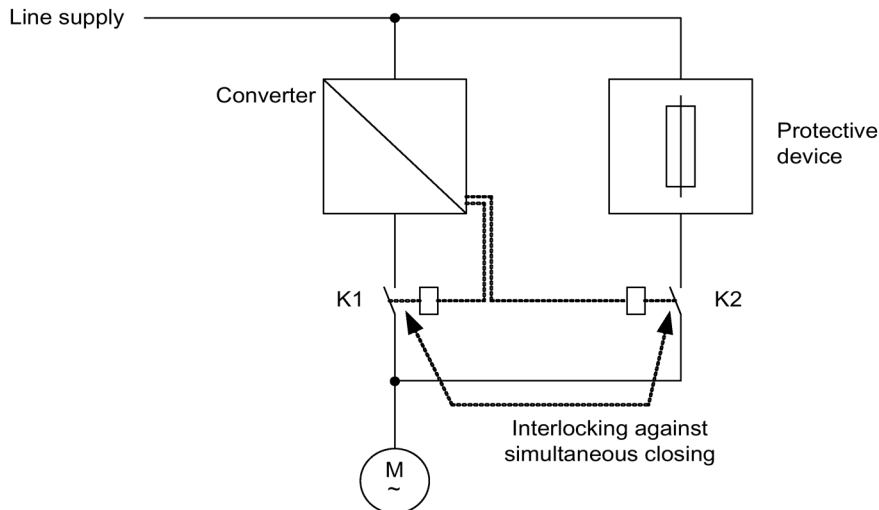

Figure 5-28 Circuit example, bypass without synchronization

Activation

The bypass without synchronization (p1260 = 3) can be triggered using the following signals (p1267):

- Bypass using a control signal (p1267.0 = 1):
The bypass can be activated using a digital signal (p1266) (e.g. from a higher-level control system). If the digital signal is withdrawn, a changeover to converter operation is initiated once the bypass delay time (p1263) has expired.
- Bypass at a specific speed threshold (p1267.1 = 1):
Once a certain speed is reached, the system switches to bypass (i.e., the drive is used as a starting drive). The bypass cannot be connected until the speed setpoint is greater than the bypass speed threshold (p1265).
The system reverts to converter mode when the setpoint (on the input of the ramp-function generator, r1119) falls below the bypass speed threshold (p1265). The setpoint > comparison value condition prevents the bypass from being reactivated straight away if the actual speed is still above the bypass speed threshold (p1265) after switching back to converter operations.

The bypass time, debypass time, bypass speed variables and the command source for changing over are set using parameters.

Parameter assignment

After activating the bypass function without synchronization (p1260 = 3) the following parameters still have to be set:

Table 5- 5 Parameter settings for non-synchronized bypass function with overlap

Parameter	Description
r1261.0 =	Control signal for contactor K1
r1261.1 =	Control signal for contactor K2
p1262 =	Setting of the dead time for non-synchronized bypass
p1263 =	Setting of the delay time to switch back to converter operation for non-synchronized bypass
p1264 =	Setting of the delay time to switch to line operation for non-synchronized bypass
p1265 =	Setting of the speed threshold for activating the bypass (for p1267.1 = 1)
p1266 =	Setting of the signal source for the control command to the bypass (for p1267.0 = 1)
p1267.0 = p1267.1 =	Trigger signal setting for bypass function
p1268	Setting of the signal source for the feedback signal "synchronization completed"
P1269[0] =	Setting of the signal source for the feedback signal of contactor K1
P1269[1] =	Setting of the signal source for the feedback signal of contactor K2
p3800 = 0	Synchronization is deactivated.
p3802 = r1261.2	Synchronizer activation is triggered by the bypass function.

5.21.5 Function diagrams and parameters

Function diagrams (see SINAMICS S120/S150 List Manual)

- 7020 Technology functions - Synchronizing

Overview of important parameters (see SINAMICS S120/S150 List Manual)

Bypass function

- p1260 Bypass configuration
- r1261.0...11 CO/BO: Bypass control/status word
- p1262[0...n] Bypass dead time
- p1263 Debypass (revert to drive) delay time
- p1264 Bypass delay time
- p1265 Bypass speed threshold
- p1266 BI: Bypass control command
- p1267 Bypass changeover source configuration
- p1268 BI: Bypass feedback signal synchronization completed
- p1269[0...1] BI: Bypass switch feedback signal

Synchronization

- p3800[0...n] Sync-line-drive activation
- p3801[0...n] Sync-line-drive drive object number
- p3802[0...n] BI: Sync-line-drive enable
- r3803.0 CO/BO: Sync-line-drive control word
- r3804 CO: Sync-line-drive target frequency
- r3805 CO: Sync-line-drive frequency difference
- p3806[0...n] Sync-line-drive frequency difference threshold value
- r3808 CO: Sync-line-drive phase difference
- p3809[0...n] Sync network drive phase setpoint value
- p3811[0...n] Sync-line-drive frequency limitation
- r3812 CO: Sync-line-drive correction frequency
- p3813[0...n] Sync-line-drive phase synchronism threshold value
- r3814 CO: Sync-line-drive voltage difference
- p3815[0...n] Sync-line-drive voltage difference threshold value
- r3819.0...7 CO/BO: Sync-line-drive status word

5.22 Asynchronous pulse frequency

The pulse frequency is coupled to the current controller cycle, and can only be adjusted in multiple integer steps. For most standard applications, this setting makes sense and should not be modified.

For certain applications, it may be advantageous if the pulse frequency is decoupled from the current controller cycle. The consequences are:

- Motor Modules or Power Modules are optimized
- Certain motor types are operated with a more favorable pulse frequency
- Motor Modules of different sizes can be operated with different pulse frequencies
- Faster sampling times can be set for DCC and free function blocks
- Faster setpoint transfers from a higher-level control system are possible
- Automatic commissioning routines with different current controller cycles are simplified

This function is enabled for Motor Modules and Power Modules in the chassis format in vector control.

Activating the function

To be able to activate the asynchronous pulse frequency, the following requirements must be satisfied:

- $r0192.16 = 1$
- $p1800 < 2 \times 1000 / p0115[0]$
- $p1810.3 = 0$

When the requirements are satisfied, the asynchronous pulse frequency (for vector control) can be activated with the parameter setting $p1810.12 = 1$.

The activation has the following effects:

- Switchover of the gating unit (p1810 bit 2)
- Switch on of the actual current value correction (p1840 bit 0)
- Minimum pulse frequency $1000 \times 0.5 / p0115[0]$
- Maximum pulse frequency $1000 \times 2 / p0115[0]$
- Fluctuating dead times and dynamic response in the current control circuit
- Increased current ripple in the current display

Application example

Situation:

A large (> 250 kW) Motor Module in the chassis format and a small (< 250 kW) Motor Module, e.g. in the booksize format, are to be connected to one DRIVE-CLiQ line.

The factory setting of the current controller cycle of the small Motor Module is 250 μ s, corresponding to a pulse frequency of 2 kHz. The factory setting of the current controller cycle of the large Motor Module is 400 μ s, corresponding to a pulse frequency of 1.25 kHz.

Problem:

For standard applications, the current controller cycle of the large Motor Module is increased up to 500 μ s, an integer multiple of the current controller cycle of 250 μ s. As a consequence, the pulse frequency of the large Motor Module is 1 kHz. As a consequence, the Motor Module in the chassis format is no longer optimally utilized.

Solution:

Activate separation of pulse frequency and current controller cycle for the large Motor Module.

The Motor Module Booksize is still operated in synchronism with the current control cycle of 250 μ s at a pulse frequency of 2 kHz.

For the Motor Module in the chassis format, set the pulse frequency to asynchronous operation with $p1800.12 = 1$. Then increase the pulse frequency of the Motor Module Chassis to 1.25 KHz using $p1800$, while the current controller cycle remains at 500 μ s. The Motor Module chassis is better utilized as a result of the increased pulse frequency.

Boundary conditions for asynchronous pulse frequency

- A higher system utilization as a result of the activated gating unit for the asynchronous pulse frequency ($p1810.12 = 1$) and the required current actual value correction ($p1840 = 1$) causes
 - Halving of the maximum number of axes that can be used
 - A reduction in the current controller dynamic response
- The maximum pulse frequency that can be set is limited to double the frequency of the current controller cycle.
- The pulse procedure, where the pulse frequency can be freely adjusted, is not suitable for a permanent-magnet synchronous motor without an encoder.
- If output reactors or filters are connected to a Motor Module in the chassis format, when dimensioning the reactors, the maximum pulse frequency must be taken into account and for sine-wave filters, the minimum pulse frequency.
- The motor data identification must be performed with current controller cycles of 250 μ s or 500 μ s with 2 kHz.

Overview of important parameters (see SINAMICS S120/S150 List Manual)

- p0115[0...6] Sampling times for internal control loops
- p1800[0...n] Pulse frequency setpoint
- p1810 Modulator configuration
- p1840[0...n] Actual value correction configuration

U/f control (vector control)

The V/f control characteristic is the simplest way to control an induction motor. When configuring the drive using the STARTER commissioning tool, V/f control is activated in the "Closed-loop control structure" screen (also see p1300).

The stator voltage of the induction motor is set proportional to the stator frequency. This procedure is used for many standard applications where the dynamic performance requirements are low, for example:

- Pumps
- Fans
- Belt drives

V/f control aims to maintain a constant flux Φ in the motor whereby the flux is proportional to the magnetizing current (I_μ) or the ratio of voltage (V) to frequency (f).

$$\Phi \sim I_\mu \sim V/f$$

The torque (M) generated by an induction motor is proportional to the product of the flux and current (the vector product $\Phi \times I$).

$$M \sim \Phi \times I$$

To generate as much torque as possible with a given current, the motor must function using the greatest possible constant flux. To maintain a constant flux (Φ), therefore, the voltage (V) must be changed in proportion to the frequency (f) to ensure a constant magnetizing current (I_μ). V/f characteristic control is derived from these basic premises.

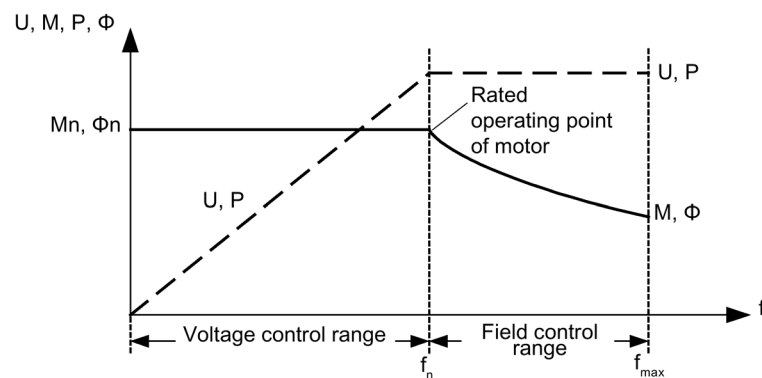
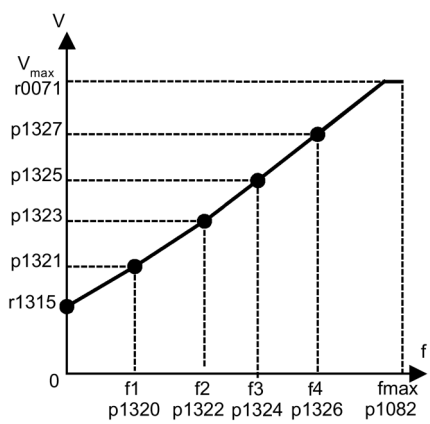

Figure 6-1 Operating areas and characteristic curves for the induction motor with converter supply

Several variations of the V/f characteristic exist, which are shown in the following table:

Table 6- 1 V/f characteristic (p1300)

Parameter values	Meaning	Application / property	
0	Linear characteristic	Standard (without voltage boost)	
1	Linear characteristic with flux current control (FCC)	Characteristic that compensates for voltage losses in the stator resistance for static/dynamic loads (flux current control FCC). This is particularly useful for small motors, since they have a relatively high stator resistance.	
2	Parabolic characteristic	Characteristic that takes into account the motor torque curve (e.g. fan/pump). <ul style="list-style-type: none"> • Quadratic characteristic (f^2 characteristic) • Energy saving because the low voltage also results in small currents and losses 	

Parameter values	Meaning	Application / property
3	Programmable characteristic	<p>Characteristic that takes into account motor/machine torque curve (e.g. synchronous motor).</p> 
4	Linear characteristic and ECO	<p>Characteristic, see parameter 0 and Eco mode at a constant operating point.</p> <ul style="list-style-type: none"> In the ECO mode, the efficiency at a constant operating point is optimized. This optimization is only effective in steady-state operation and when the ramp-function generator is not bypassed. You must activate slip compensation and set the scaling of the slip compensation (p1335) so that the slip is completely compensated (generally, 100%).
5	Precise frequency drives	<p>Characteristic that takes into account the technological particularity of an application (e.g. textile applications):</p> <ul style="list-style-type: none"> Whereby the current limitation (I_{max} controller) only affects the output voltage and not the output frequency By disabling slip compensation
6	Precise frequency drives with flux current control (FCC)	<p>Characteristic that takes into account the technological particularity of an application (e.g. textile applications):</p> <ul style="list-style-type: none"> Whereby the current limitation (I_{max} controller) only affects the output voltage and not the output frequency By disabling slip compensation <p>Voltage losses in the stator resistance for static/dynamic loads are also compensated (flux current control FCC). This function is required for small motors, as, in comparison to large motors, they have a relatively high stator resistance.</p>
7	Parabolic characteristic and ECO	<p>Characteristic, see parameter 1 and ECO mode at a constant operating point.</p> <ul style="list-style-type: none"> In the Eco mode, the efficiency at a constant operating point is optimized. This optimization is only effective in steady-state operation and when the ramp-function generator is not bypassed. You must activate slip compensation and set the scaling of the slip compensation (p1335) so that the slip is completely compensated (generally, 100%).
19	Independent voltage setpoint	<p>The user can define the output voltage of the Motor Module independently of the frequency using BICO parameter p1330 via the interfaces (e.g. analog input AI0 of Terminal Board 30 → p1330 = r4055[0]).</p>

Function diagram

- 6300 Vector control - U/f control, overview
- 6301 Vector control - V/f characteristic and voltage boost

Parameter

- p1300[0...n] Open-loop/closed-loop control operating mode
- p1320[0...n] U/f control programmable characteristic frequency 1
- ...
- p1327[0...n] U/f control programmable characteristic voltage 4
- p1330[0...n] CI: U/f control independent of voltage setpoint
- p1331[0...n] Voltage limitation
- p1333[0...n] U/f control FCC starting frequency
- r1348 CO: U/f control Eco factor actual value
- p1350[0...n] U/f control soft starting

6.1 Voltage boost

According to the V/f characteristic, at an output frequency of 0 Hz, the control supplies an output voltage of 0 V. This means that at 0 V, the motor cannot generate any torque. There are several reasons for the use of the "Voltage boost" function:

- Magnetization build-up of an induction motor at $n = 0$ rpm
- Build-up of a torque at $n = 0$ rpm, e.g. in order to hold a load
- Generation of a breakaway, acceleration or braking torque
- Compensation of ohmic losses in the windings and feeder cables

Types of voltage boost

Three types of voltage boost can be selected:

- Permanent voltage boost with p1310
- Voltage boost only while accelerating with p1311
- Voltage boost only while starting for the first time with p1312

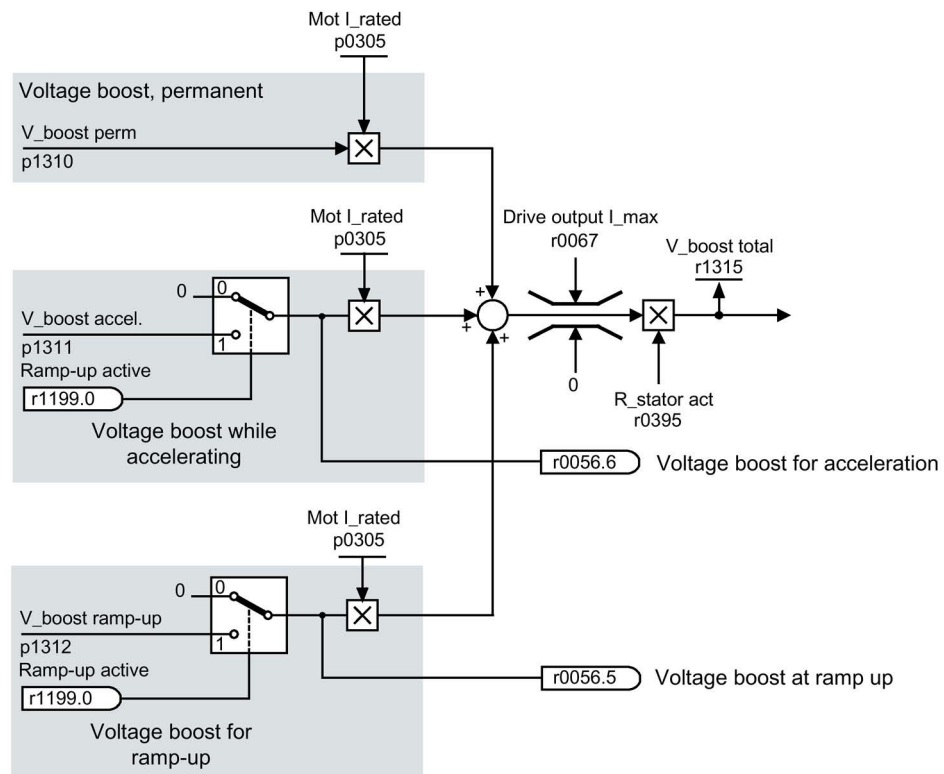

Figure 6-2 Voltage boost total

Note

The voltage boost affects all V/f characteristics (p1300).

Note

Excessive motor temperature rise as a result of excessive voltage boost

If the voltage boost value is too high, this can result in an excessively high motor winding temperature increase - and therefore result in a shutdown (trip).

Voltage boost, permanent

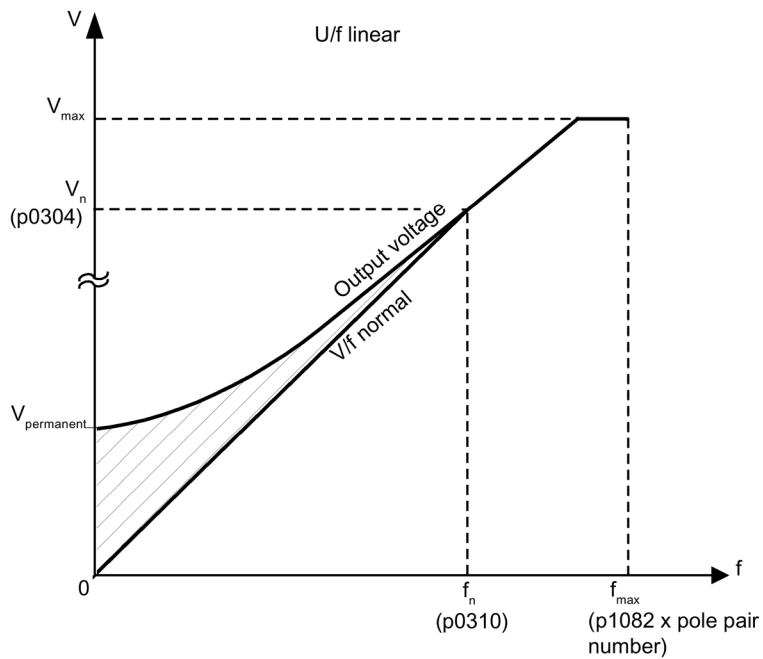

$$V_{\text{permanent}} = p0305 \text{ (motor rated current)} \times p0395 \text{ (current stator resistance)} \times p1310 \text{ (permanent voltage boost)}$$

Figure 6-3 Permanent voltage boost (example: p1300 = 0 and p1310 > 0)

Voltage boost while accelerating

Voltage boost while accelerating is effective if the ramp-function generators provide the feedback signal "ramp-up active" ($r1199.0 = 1$).

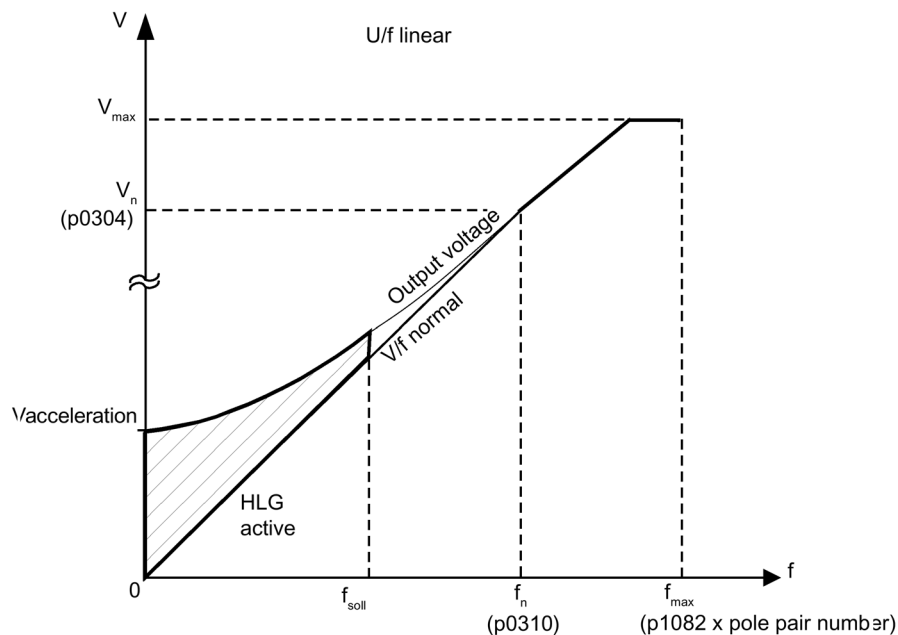

$$V_{acceleration} = p0305 \text{ (motor rated current} \times p0395 \text{ (current stator resistance)} \times p1311 \text{ (voltage for acceleration)}$$

Figure 6-4 Voltage boost while accelerating (example: $p1300 = 0$ and $p1311 > 0$)

Function diagrams (see SINAMICS S120/S150 List Manual)

- 6301 Vector control - V/f characteristic and voltage boost

Overview of important parameters (see SINAMICS S120/S150 List Manual)

- p0304[0...n] Rated motor voltage
- p0305[0...n] Rated motor current
- r0395[0...n] Current stator resistance
- p1300[0...n] Open-loop/closed-loop control operating mode
- p1310[0...n] Starting current (voltage boost) permanent
- p1311[0...n] Starting current (voltage boost) acceleration
- p1312[0...n] Starting current (voltage boost) when starting
- r1315 Voltage boost total

6.2 Slip compensation

The slip compensation ensures that the motor setpoint speed n_{set} of induction motors is essentially kept constant independent of the load. For a load step from M1 to M2, the setpoint frequency should be automatically increased, so that the resulting frequency and therefore the motor speed is kept constant. When the load decreases from M2 to M1, then the setpoint frequency is automatically reduced.

If a motor holding brake is used, a setting value can be specified at the slip compensation output via p1351. A parameter setting of $p1351 > 0$ automatically activates the slip compensation ($p1335 = 100\%$).

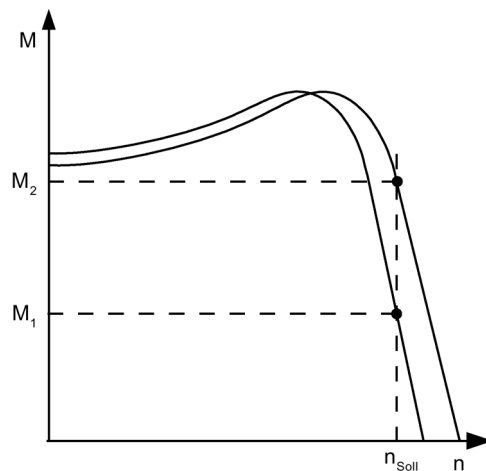

Figure 6-5 Slip compensation

Overview of important parameters (see SINAMICS S120/S150 List Manual)

- r0330[0...n] Rated motor slip
- p1334[0...n] V/f control slip compensation starting frequency
- p1335[0...n] Slip compensation scaling
 p1335 = 0.0 % The slip compensation is deactivated.
 p1335 = 100.0 The slip is fully compensated.
 %:
- p1336[0...n] Slip compensation limit value
- r1337 CO: Actual slip compensation
- p1351[0...n] CO: Motor holding brake start frequency

6.3 Resonance damping

The resonance damping function dampens active current oscillations that can occur under no-load conditions. Resonance damping is active in a range between 5% and 90% of the rated motor frequency (p0310), but only up to 45 Hz.

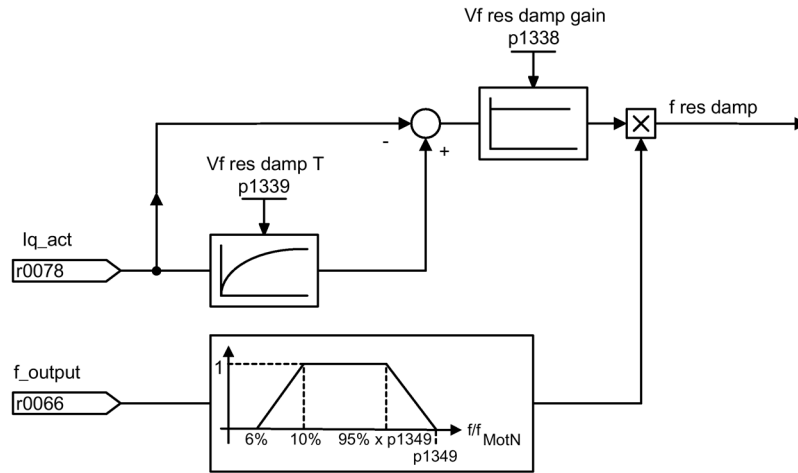

Figure 6-6 Resonance damping

Note

Maximum frequency resonance damping

When p1349 = 0, the changeover limit is automatically set to 95% of the rated motor frequency, but only up to a maximum of 45 Hz.

Function diagrams (see SINAMICS S120/S150 List Manual)

- 6310 Vector control - Resonance damping and slip compensation

Overview of important parameters (see SINAMICS S120/S150 List Manual)

- r0066 CO: Output frequency
- r0078 CO: Torque-generating actual current value
- p0310[0...n] Rated motor frequency
- p1338[0...n] V/f mode resonance damping gain
- p1339[0...n] V/f mode resonance damping filter time constant
- p1349[0...n] V/f mode resonance damping maximum frequency

6.4 Vdc control

The "Vdc control" function can be activated using the appropriate measures if an overvoltage or undervoltage is present in the DC link.

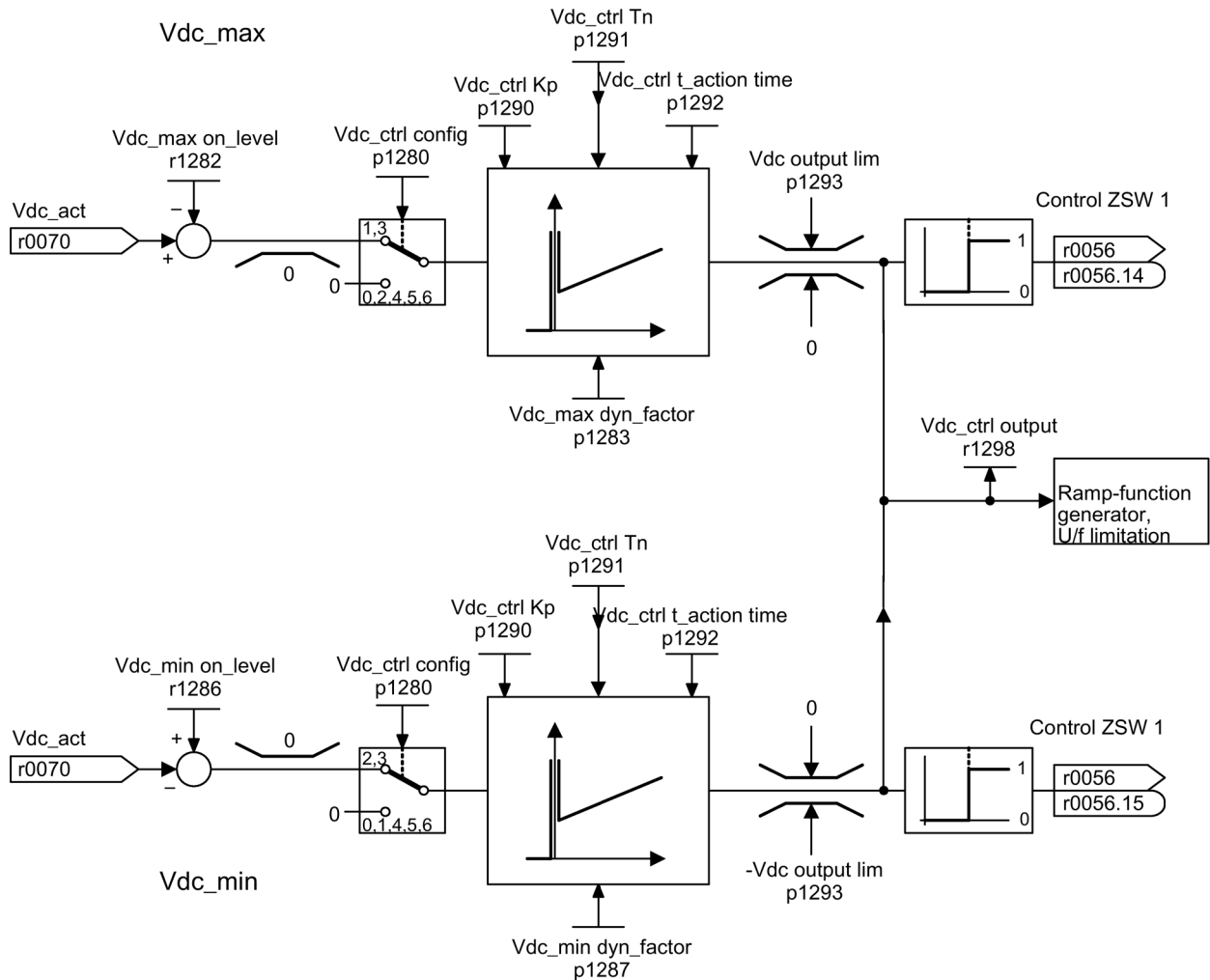

Figure 6-7 V_{dc} control V/f

Undervoltage in the DC link

- Typical cause:

Failure of the supply voltage or supply for the DC link.

- Remedy:

Specify a regenerative torque for the rotating drive to compensate the existing losses, thereby stabilizing the voltage in the DC link (kinetic buffering).

Overvoltage in the DC link

- Typical cause:

The drive is operating in regenerative mode and is supplying too much energy to the DC link.

- Remedy:

Reduce the regenerative torque to maintain the DC link voltage within permissible limits.

Properties

- V_{dc} control

- This comprises V_{dc_max} control and V_{dc_min} control (kinetic buffering). These two functions can be parameterized independently of one another and activated.

- There is a common PID controller. The dynamic factor is used to set V_{dc_min} and V_{dc_max} control to a smoother or harder setting independently of each other.

- V_{dc_min} control (kinetic buffering)

- With this function, the kinetic energy of the motor is used for buffering the DC link voltage in the event of a momentary power failure, thereby delaying the drive.

- V_{dc_max} control

- This function can be used to control momentary regenerative load without shutdown using "overvoltage in the DC link".

- V_{dc_max} control is only recommended with a supply without active closed-loop control for the DC link and without feedback.

Vdc_min control

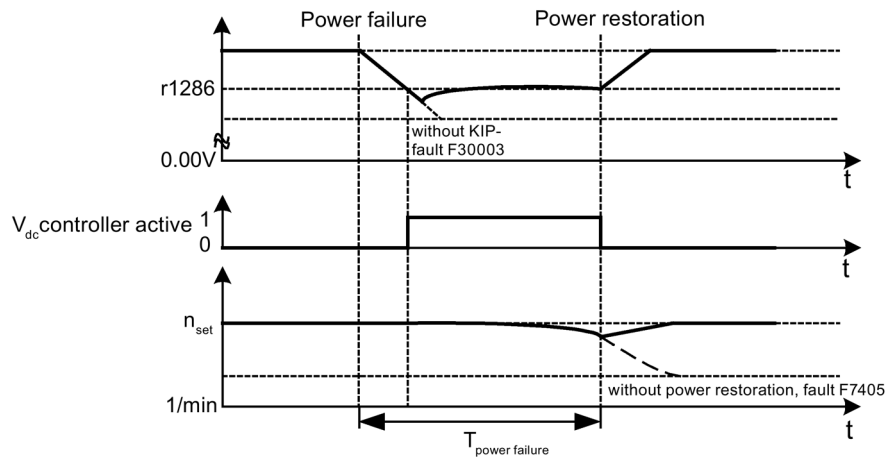

Figure 6-8 Switching V_{dc_min} control on/off (kinetic buffering)

In the event of a power failure, V_{dc_min} is activated when the V_{dc_min} switch-on level is undershot. This controls the DC link voltage and maintains it at a constant level. The motor speed is reduced.

When the line supply returns, the DC link voltage increases again. 5% above the V_{dc_min} switch-on level, the V_{dc_min} control is switched off again. The motor continues operating normally.

If the power supply is not re-established, the motor speed continues to drop. When the threshold in p1297 is reached, this results in a response in accordance with p1296.

Once the time threshold (p1295) has elapsed without the line voltage being re-established, a fault is triggered (F07406), which can be parameterized as required (factory setting: OFF3).

The V_{dc_min} controller can be activated for a drive. Other drives can participate in supporting the DC link, by transferring to them a scaling of their speed setpoint from the controlling drive via BICO interconnection.

Note

If it is expected that the line supply will return, you must make sure that the converter is not disconnected from the line supply. It could become disconnected, for example, if the line contactor drops out. The line contactor must be supplied, e.g. from an uninterruptible power supply (UPS).

Vdc_max control

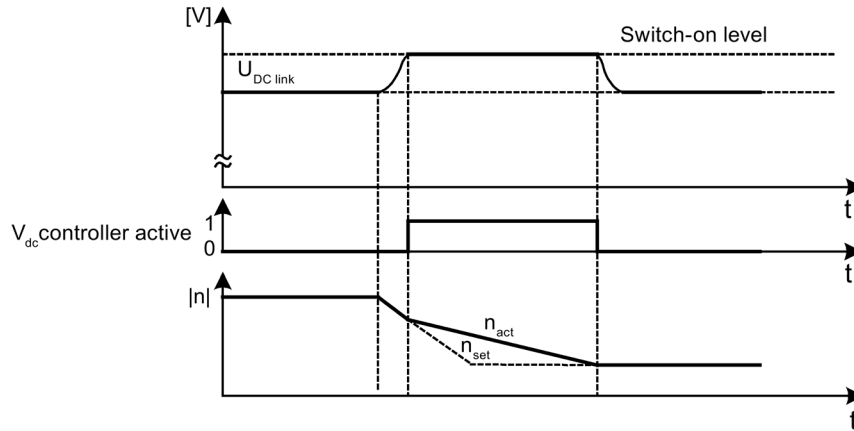

Figure 6-9 Switching the V_{dc_max} control on/off

The switch-on level for V_{dc_max} -control (r1282) is calculated as follows:

p1294 (automatic sensing of the ON level (U/f))		Switch-on level of the V_{dc_max} control (r1282)	Comment
Value	Meaning		
= 0	Switched out	$r1282 = 1.15 \times p0210$	$p0210 \triangleq$ device supply voltage
= 1	Switched in	$r1282 = V_{dc_max} - 50\ V$	$V_{dc_max} \triangleq$ overvoltage threshold of the Motor Module

If several Motor Modules are supplied from a non-regenerative infeed unit (e.g. a Basic Line Module), or for power failure or overload (for SLM/ALM), the V_{dc_max} control may only be activated for a Motor Module whose drive should have a high moment of inertia.

For the other Motor Modules this function must be disabled or monitoring must be set.

If the V_{dc_max} control is active for several Motor Modules, then for an unfavorable parameterization, the controllers can mutually influence one another negatively. The drives can become unstable, individual drives can unintentionally accelerate.

Remedial measures:

- Activating the Vdc_max control:
 - Vector control: p1240 = 1 (factory setting)
 - Servo control: p1240 = 1
 - U/f control: p1280 = 1 (factory setting)
- Inhibiting the Vdc_max control:
 - Vector control: p1240 = 0
 - Servo control: p1240 = 0 (factory setting)
 - U/f control: p1280 = 0
- Activating the Vdc_max monitoring function
 - Vector control: p1240 = 4 or 6
 - Servo control: p1240 = 4 or 6
 - U/f control: p1280 = 4 or 6

 **WARNING****Danger to life as a result of unplanned motion of individual drives**

If several Motor Modules are supplied from one infeed unit, then if the Vdc_max control is incorrectly parameterized, individual drives can accelerate in an uncontrolled fashion - which can lead to death or severe injury.

- Only activate the Vdc_max control for the Motor Module whose drive has the highest moment of inertia.
- Inhibit this function for all other Motor Modules, or set this function to monitoring only.

Function diagrams (see SINAMICS S120/S150 List Manual)

- 6320 Vector control - Vdc_max controller and Vdc_min controller (V/f)

Overview of important parameters (see SINAMICS S120/S150 List Manual)

- p1280[0...n] Vdc controller or Vdc monitoring configuration (V/f)
- r1282 Vdc_max controller switch-on level (V/f)
- p1283[0...n] Vdc_max controller dynamic factor (V/f)
- p1285[0...n] Vdc_min controller switch-on level (kinetic buffering) (V/f)
- r1286 Vdc_min controller switch-on level (kinetic buffering) (V/f)
- p1287[0...n] Vdc_min controller dynamic factor (kinetic buffering) (V/f)
- p1290[0...n] Vdc controller proportional gain (V/f)
- p1291[0...n] Vdc controller integral time (V/f)
- p1292[0...n] Vdc controller derivative time (V/f)
- p1293[0...n] Vdc_min controller output limit (V/f)
- p1294 Vdc_max controller automatic detection ON signal level (V/f)
- p1295[0...n] Vdc_min controller time threshold (V/f)
- p1296[0...n] Vdc_min controller response (kinetic buffering) (V/f)
- p1297[0...n] Vdc_min controller speed threshold (V/f)
- r1298 CO: Vdc controller output (V/f)

Basic functions

7.1 Switching over units

By changing over the units, parameters and process quantities for input and output can be changed over to an appropriate system of units (US units or as per unit quantities (%)).

The following supplementary conditions apply when changing over units:

- Parameters of the drive converter rating plate or the motor rating plate can be changed over between SI/US units; however, a per unit representation is not possible.
- After changing over the units parameter, all parameters that are assigned to one of the units group dependent on it, are all changed over to the new system of units.
- A parameter is available to select technological units (p0595) to represent technological quantities in the technology controller.
- If the units are converted to per unit quantities and the reference quantity changed, the percentage value entered in a parameter is not changed.

Example:

- A fixed speed of 80% corresponds, for a reference speed of 1500 RPM, to a value of 1200 RPM.
- If the reference speed is changed to 3000 RPM, then the value of 80% is kept and now means 2400 RPM.

Restrictions

- When a unit changeover occurs, rounding to the decimal places is carried out. This can mean that the original value might change by up to one decimal place.
- If a referenced form is selected and the reference parameters (e.g. p2000) are changed retrospectively, the referenced values of some of the control parameters are also adjusted to ensure that the control behavior is unaffected.
- If the reference variables (p2000 to p2007) are changed offline in STARTER, there is a risk that the parameter value ranges will be violated. In this case, appropriate fault messages will be displayed when the parameters are loaded to the drive unit.

Groups of units

Every parameter that can be changed over is assigned to a units group, that, depending on the group, can be changed over within certain limits.

This assignment and the unit groups can be read for each parameter in the parameter list in the SINAMICS S120/S150 List Manual.

The unit groups can be individually switched using 4 parameters (p0100, p0349, p0505 and p0595).

Function in STARTER

The function for unit system switchover in STARTER can be found via the menu path "Drive object" > "Configuration" > "Units".

The reference parameters can be found via the menu path "Drive object" > "Configuration" > "Reference parameters".

Overview of the important parameters (see SINAMICS S120/S150 List Manual)

- p0010 Infeed, commissioning parameter filter
- p0100 IEC/NEMA motor standard
- p0349 Unit system, motor equivalent circuit diagram data
- p0505 Unit system selection
- p0595 Technological unit selection
- p0596 Technological unit reference variable
- p2000 Reference speed reference frequency
- p2001 Reference voltage
- p2002 Reference current
- p2003 Reference torque
- r2004 Reference power
- p2005 Reference angle
- p2006 Reference temperature
- p2007 Reference acceleration

7.2 Reference parameters/scaling

Reference values, corresponding to 100%, are required to display units as percentages. These reference values are entered in parameters p2000 to p2007. They are computed during the calculation through p0340 = 1 or in STARTER during drive configuration. After calculation in the drive, these parameters are automatically protected via p0573 = 1 from boundary violation through a new calculation (p0340). This eliminates the need to adjust the reference values in a PROFIdrive controller whenever a new calculation of the reference parameters via p0340 takes place.

Parameters p0514 ... p0519 are provided for scaling purposes when interconnecting BICO parameters (also see SINAMICS S120/S150 List Manual).

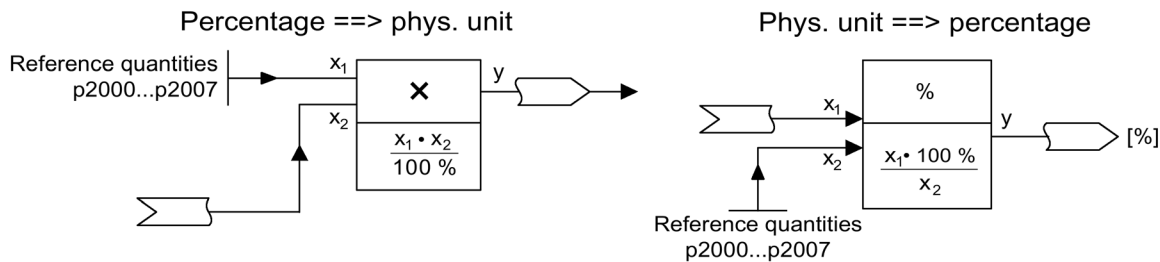

Figure 7-1 Illustration of conversion with reference values

Note

If a referenced form is selected and the reference parameters (e.g. p2000) are changed retrospectively, the referenced values of some of the control parameters are also adjusted to ensure that the control behavior is unaffected.

Using STARTER offline

After the offline drive configuration, the reference parameters are preset. You can call the configuration of these parameters via the menu path "Drive > Configuration". On the "Disabled list" tab, the parameters can be changed and protected.

Note

If the reference values (p2000 to p2007) are changed offline in STARTER, it can lead to limit violations of the parameter values, which cause alarms or faults when loading to the drive unit.

Scaling for the VECTOR drive object

Table 7- 1 Scaling for the VECTOR drive object

Size	Scaling parameter	Default when commissioning for the first time
Reference speed	100% = p2000	p2000 = Maximum speed (p1082)
Reference voltage	100% = p2001	p2001 = 1000 V
Reference current	100% = p2002	p2002 = Current limit (p0640)
Reference torque	100% = p2003	p2003 = 2 * rated motor torque (p0333)
Reference power	100% = r2004	r2004 = p2003 * p2000 * 2π / 60
Reference angle	100% = p2005	90°
Reference acceleration	100% = p2007	0.01 1/s ²
Reference frequency	100% = p2000/60	-
Reference modulation depth	100% = Maximum output voltage without overload	-
Reference flux	100% = Rated motor flux	-
Reference temperature	100 % = p2006	100°C
Reference electrical angle	100 % = p2005	90°

Note**Operation of motors in the field-weakening range**

If the motors are to be operated in the field-weakening range > 2:1, the value of parameter p2000 must be set $\leq 1/2$ x maximum speed of the drive object.

Scaling for the SERVO drive object

Table 7- 2 Scaling for the SERVO drive object

Size	Scaling parameter	Default when commissioning for the first time
Reference speed	100% = p2000	Induction motor p2000 = Maximum motor speed (p0322) Synchronous motor p2000 = Rated motor speed (p0311)
Reference voltage	100% = p2001	p2001 = 1000 V
Reference current	100% = p2002	p2002 = Motor limit current (p0338); when p0338 = "0", 2 * rated motor current (p0305)
Reference torque	100% = p2003	p2003 = p0338 * p0334; when "0", 2 * rated motor torque (p0333)
Reference power	100% = r2004	r2004 = p2003 * p2000 * π / 30
Reference angle	100% = p2005	90°
Reference acceleration	100% = p2007	0.01 1/s ²
Reference frequency	100% = p2000/60	-
Reference modulation depth	100% = Maximum output voltage without overload	-
Reference flux	100% = Rated motor flux	-
Reference temperature	100 % = p2006	100°C
Reference electrical angle	100 % = p2005	90°

Note

Operation of motors in the field-weakening range

If the motors are to be operated in the field-weakening range > 2:1, the value of parameter p2000 must be set $\leq 1/2$ x maximum speed of the drive object.

Scaling for the A_INF drive object

Table 7- 3 Scaling for the A_INF drive object

Size	Scaling parameter	Default when commissioning for the first time
Reference frequency	100% = p2000	p2000 = p0211
Reference voltage	100% = p2001	p2001 = p0210
Reference current	100% = p2002	p2002 = r0206/p0210/ $\sqrt{3}$
Reference power	100% = r2004	r2004 = r0206
Reference modulation depth	100% = Maximum output voltage without overload	-
Reference temperature	100 % = p2006	100°C
Reference electrical angle	100 % = p2005	90°

Scaling for the S_INF drive object

Table 7- 4 Scaling for the S_INF drive object

Size	Scaling parameter	Default when commissioning for the first time
Reference frequency	100% = p2000	p2000 = 50 Hz
Reference voltage	100% = p2001	p2001 = p0210
Reference current	100% = p2002	p2002 = r0206/p0210/ $\sqrt{3}$
Reference power	100% = r2004	r2004 = r0206
Reference modulation depth	100% = Maximum output voltage without overload	-
Reference temperature	100 % = p2006	100°C
Reference electrical angle	100 % = p2005	90°

Scaling for the B_INF drive object

Table 7- 5 Scaling for the B_INF drive object

Size	Scaling parameter	Default when commissioning for the first time
Reference frequency	100% = p2000	p2000 = 50 Hz
Reference voltage	100% = p2001	p2001 = p0210
Reference current	100% = p2002	p2002 = r0206/p0210/ $\sqrt{3}$
Reference power	100% = r2004	r2004 = r0206
Reference temperature	100 % = p2006	100°C
Reference electrical angle	100 % = p2005	90°

Overview of important parameters (see SINAMICS S120/S150 List Manual)

- r0206[0...4] Rated power module power
- p0210 Device supply voltage
- p0340[0...n] Automatic calculation of motor/control parameters
- p0573 Inhibit automatic reference value calculation
- p2000 Reference speed reference frequency
- p2001 Reference voltage
- p2002 Reference current
- p2003 Reference torque
- r2004 Reference power
- p2005 Reference angle
- p2006 Reference temperature
- p2007 Reference acceleration
- p0514[0...9] Specific scaling, reference values
- p0515[0...19] Specific scaling, parameter referred to p0514[0]
- p0516[0...19] Specific scaling, parameter referred to p0514[1]
- p0517[0...19] Specific scaling, parameter referred to p0514[2]
- p0518[0...19] Specific scaling, parameter referred to p0514[3]
- p0519[0...19] Specific scaling, parameter referred to p0514[4]
- p0520[0...19] Specific scaling, parameter referred to p0514[5]
- p0521[0...19] Specific scaling, parameter referred to p0514[6]
- p0522[0...19] Specific scaling, parameter referred to p0514[7]
- p0523[0...19] Specific scaling, parameter referred to p0514[8]
- p0524[0...19] Specific scaling, parameter referred to p0514[9]

7.3 Configuring the short-circuit/ground fault test mode

When switching on the power unit, test pulses can be generated that check the connection between the power unit and motor - or the motor winding itself - for a short-circuit or ground fault.

This function is only available for vector control.

Depending on the configuration in p1901, you can define as to whether only the short circuit test is executed - or additionally, also a ground fault test (with higher current pulses).

p1901.0	Checks for a conductor-conductor short-circuit once when the pulses are enabled.
p1901.1	Checks for a ground fault once when the pulses are enabled.
p1901.2	Checks for a conductor-conductor short-circuit and ground fault each time the pulses are enabled.

The test can be executed once after the Control Unit is switched on (POWER ON) or each time that the pulses are enabled.

The motor must be stationary when executing the ground fault test. This is the reason that when the "Flying restart" function is activated (p1200 = 0) a ground fault test is not executed.

The tests slightly delay motor starting, depending on the selection in p1901. The result of the short-circuit or ground fault test is indicated in r1902.

Note

The ground fault and short-circuit test is automatically deactivated as soon as a sine-wave filter is connected. The test pulses can excite the filter.

7.4 Modular machine concept

The modular machine concept is based on a maximum topology created "offline" in STARTER. The maximum design of a particular machine type is referred to as the maximum configuration in which all the machine components that may be used are pre-configured in the target topology. Sections of the maximum configuration can be removed by deactivating/removing drive objects (p0105 = 2).

If a component fails, the sub-topology can also be used to allow a machine to continue running until the spare part is available. In this case, however, no BICO source must be interconnected from this drive object to other drive objects.

Example of a sub-topology

The starting point is a machine created offline in STARTER for which "Drive 1" has not yet been implemented.

- Object "Drive 1" must be removed from the target topology via p0105 = 2 in the "offline" mode.
- The DRIVE-CLiQ cable is reconnected from the Control Unit directly to "Drive 2".
- Download the project by choosing "Load to drive object".
- Copy from RAM to ROM.

Figure 7-2 Example of a sub-topology

Note**Incorrect SI status display**

If a drive in a Safety Integrated drive line-up is deactivated using p0105, then r9774 is not correctly output. The signals of a deactivated drive are no longer updated.

Overview of important parameters (see SINAMICS S120/S150 List Manual)

- p0105 Activate/deactivate drive object
- r0106 Drive object active/inactive
- p0125[0...n] Activate/deactivate power unit component
- r0126[0...n] Power unit components active/inactive
- p0145 Enable/disable sensor interface
- r0146 Sensor interface active/inactive
- p9495 BICO behavior for deactivated drive objects
- p9496 BICO behavior when activating drive objects
- r9498[0 ... 29] BICO BI/CI parameters for deactivated drive objects
- r9499[0 ... 29] BICO BO/CO parameters for deactivated drive objects

7.5 Sine-wave filter

The sine-wave filter limits the voltage rate-of-rise and the capacitive charge/discharge currents that usually occur with converter operation. It also prevents additional noise caused by the pulse frequency. The service life of the motor is the same as that with direct line operation.

The sine-wave filter is only available for vector control.

NOTICE

Damage to a sine-wave filter through incorrect parameter assignment

The sine-wave filter can be damaged as a result of an incorrect parameter assignment.

- Activate the sine-wave filter during commissioning via parameter p0230 = 3.

NOTICE

Damage to the sine-wave filter if a motor is not connected

Sine-wave filters, which are operated without a motor being connected, can be damaged or destroyed.

- Never operate a sine-wave filter on the Power Module or Motor Module without a connected motor.

Usage restrictions for sine-wave filters

The following restrictions must be taken into account when a sine-wave filter is used:

- The output frequency is limited to a maximum of 150 Hz.
- The modulation type is permanently set to space vector modulation without overload. This reduces the maximum output voltage to approx. 85% of the rated output voltage.
- Maximum permissible motor cable lengths:
 - Unshielded cables: Max. 450 m
 - Shielded cables: Max. 300 m
- Further restrictions are contained in the following device manuals:
 - SINAMICS S120 AC Drive
 - SINAMICS S120 air-cooled chassis power units
 - SINAMICS S120 liquid-cooled chassis power units

Note

If a filter cannot be parameterized (p0230 < 3), this means that a filter has not been provided for the component. In this case, the drive converter must not be operated with a sine-wave filter.

Table 7- 6 Parameter settings for sine-wave filters

Parameter number	Name	Setting
p0233	Power unit motor reactor	Filter inductance
p0234	Power unit sine-wave filter capacitance	Filter capacitance
p0290	Power unit overload response	Disable pulse frequency reduction
p1082	Maximum speed	Fmax filter / pole pair number
p1800	Pulse frequency	Nominal pulse frequency of the filter
p1802	Modulator modes	Space vector modulation without overload

7.6 Motor reactors

Motor reactors reduce the voltage load on the motor windings by reducing the voltage gradients at the motor terminals that occur during converter operation. At the same time, the capacitive charge/discharge currents that occur at the converter output when long motor cables are used are reduced. This function is only available for vector control.

Restrictions

The following restrictions must be taken into account when a motor reactor is used:

- The output frequency is limited:
 - Booksize power units: To maximum 120 Hz.
 - Blocksize and chassis power units: To maximum 150 Hz.
- Maximum permissible motor cable lengths are limited and depend on the number of motor reactors connected in series.

For details, see the following device manuals:

- SINAMICS S120 AC Drive
- SINAMICS S120 booksize power units
- SINAMICS S120 air-cooled chassis power units
- SINAMICS S120 liquid-cooled chassis power units

For Booksize and Blocksize power units, the maximum permissible pulse frequency for the motor reactor is the rated pulse frequency (4 kHz), for chassis power units, twice the rated pulse frequency (2.5 kHz from 315 kW to 800 kW for 400 V - or 75 kW up to 1200 kW for 690 V - or 4 kHz up to 250 kW for 400 V).

NOTICE
Damage to the motor reactor if the maximum pulse frequency is exceeded
Inadmissibly high pulse frequencies can damage the motor reactor.
<ul style="list-style-type: none">• Do not exceed maximum permissible pulse frequency.

Commissioning

1. Activate the motor reactors during commissioning (p0230 = 1).
2. Enter the number of motor reactors connected in series via p0235.

Overview of important parameters (see SINAMICS S120/S150 List Manual)

- p0230 Drive filter type, motor side
- p0233 Power unit motor reactor
- p0235 Number of motor reactors in series

7.7 dv/dt filter plus Voltage Peak Limiter

The dv/dt filter plus Voltage Peak Limiter consists of two components: The dv/dt reactor and the voltage limiting network (Voltage Peak Limiter, VPL), which cuts off the voltage peaks and feeds back the energy to the DC link.

This function is only available for vector control.

The dv/dt filter plus Voltage Peak Limiter is designed for use with motors for which the voltage strength of the insulation system is unknown or insufficient. Standard motors of the 1LA5, 1LA6 and 1LA8 series only require them at supply voltages $> 500 \text{ V} + 10\%$.

The dv/dt filter plus Voltage Peak Limiter limits the rate of voltage rise to values $< 500 \text{ V}/\mu\text{s}$ and the typical voltage peaks to the values below (with motor cable lengths of $< 150 \text{ m}$):

- Voltage peaks \hat{U}_{LL} (typically) $< 1000 \text{ V}$ for $V_{line} < 575 \text{ V}$
- Voltage peaks \hat{U}_{LL} (typically) $< 1250 \text{ V}$ for $660 \text{ V} < V_{line} < 690 \text{ V}$

Restrictions

The following restrictions must be taken into account when a dv/dt filter is used:

- The output frequency is limited to a maximum of 150 Hz.
- Maximum permissible motor cable lengths:
 - Shielded cables: Max. 300 m
 - Unshielded cables: Max. 450 m
- Further restrictions are contained in the following device manuals:
 - SINAMICS S120 AC Drive
 - SINAMICS S120 air-cooled chassis power units
 - SINAMICS S120 chassis power units, liquid-cooled

The maximum permissible pulse frequency when using a du/dt filter:

- For 2.5 kHz
 - Chassis power units from 315 kW to 800 kW at 400 V
 - Chassis power units from 75 kW to 1200 kW at 690 V
- For 4 kHz
 - Chassis power units up to 250 kW at 400 V

NOTICE

Damage to the du/dt filter by exceeding the maximum pulse frequency

Inadmissibly high pulse frequencies can damage the du/dt filter.

- Do not exceed maximum permissible pulse frequency.

Commissioning

The dv/dt filter must be activated when commissioning the system (p0230 = 2).

7.8 dv/dt filter compact plus Voltage Peak Limiter

The dv/dt filter compact plus Voltage Peak Limiter consists of two components: The dv/dt reactor and the voltage limiting network (Voltage Peak Limiter, VPL). A VPL cuts off the voltage peaks and feeds the energy back into the DC link.

This function is only available for vector control.

The dv/dt filter compact plus Voltage Peak Limiter is designed for use with motors for which the voltage strength is unknown or is insufficient.

The du/dt filters compact plus voltage peak limiter limit the voltage load on the motor cables to values in accordance with the limit value curve A according to IEC/TS 60034-25:2007.

The voltage rate-of-rise is limited to $< 1600 \text{ V}/\mu\text{s}$. The voltage peaks are limited to $< 1400 \text{ V}$.

Continuous operation is only permissible for output frequencies higher than 10 Hz.

For short-time operation, output frequencies less than 10 Hz are permissible for a maximum of 5 minutes. However, this must be followed by a minimum period of 5 minutes, where the output frequency is higher than 10 Hz.

NOTICE

Damage to the du/dt filter compact plus voltage peak limiter during continuous operation at low output frequencies

Continuous operation with output frequencies of less than 10 Hz - or not complying with the permissible time ratings - can thermally destroy the du/dt filter.

- Comply with the specifications.

The maximum permissible pulse frequency when using a du/dt filter:

- For 2.5 kHz
 - Chassis power units from 315 kW to 800 kW at 400 V
 - Chassis power units from 75 kW to 1200 kW at 690 V
- For 4 kHz
 - Chassis power units up to 250 kW at 400 V

NOTICE

Damage to the du/dt filter compact with voltage peak limiter by exceeding the maximum pulse frequency

Inadmissibly high pulse frequencies can damage the du/dt filter compact with voltage peak limiter.

- Do not exceed maximum permissible pulse frequency.

Restrictions

The following restrictions must be taken into account when a dv/dt filter is used:

- The output frequency is limited to a maximum of 150 Hz.
- Maximum permissible motor cable lengths:
 - Shielded cables: Max. 100 m
 - Unshielded cables: Max. 150 m
- Further restrictions are contained in the following device manuals:
 - SINAMICS S120 AC Drive
 - SINAMICS S120 air-cooled chassis power units
 - SINAMICS S120 chassis power units, liquid-cooled

Commissioning

During commissioning, you must activate the dv/dt filter with $p0230 = 2$.

7.9 Pulse frequency wobbling

The function is only available for Motor Modules in the chassis format with DRIVE-CLiQ (Article numbers: 6SL3...-.....-...3) in vector control.

Pulse frequency wobbling damps the spectral components, which can generate unwanted noise in the motor. Wobbling can be activated only for pulse frequencies that are lower than or equal to the current controller frequency (see also p0115[0]).

Wobbling causes the pulse frequency in a modulation interval to deviate from the setpoint frequency. This means that the actual pulse frequency might be higher than the average pulse frequency required.

A noise generator can be used to vary the pulse frequency around an average value. In this case, the average pulse frequency is equal to the setpoint pulse frequency. The pulse frequency can be varied in every current controller cycle if the cycle is constant. Current measurement errors resulting from asynchronous pulse and control intervals are compensated by a correction in the actual current value.

Pulse frequency wobbling can be parameterized with parameter p1810 "Modulator configuration".

Parameter p1811[0...n] "Pulse frequency wobbling amplitude" can be set to adjust the magnitude of variation in the pulse frequency wobble to between 0 and 20%. The factory setting is 0%. For a wobble amplitude of p1811 = 0%, the maximum possible pulse frequency is $p1800 = 2 * 1/\text{current controller cycle}$ ($1000/p0115[0]$). With a wobble amplitude setting of p1811 > 0, the maximum possible pulse frequency is $p1800 = 1/\text{current controller cycle}$ ($1000/p0115[0]$). These conditions apply to all indices.

Note

If pulse frequency wobbling is deactivated, parameter p1811 is set to "0" in all of the indices.

Overview of important parameters (see SINAMICS S120/S150 List Manual)

- p1810 Modulator configuration
- p1811[0...n] Pulse frequency wobbling amplitude

7.10 Direction reversal without changing the setpoint

The direction of rotation of the motor can be reversed using the direction reversal via p1821 without having to change the motor rotating field by interchanging two phases at the motor and having to invert the encoder signals using p0410.

The direction reversal via p1821 can be detected as a result of the motor direction of rotation. The speed setpoint and actual value, torque setpoint and actual value and also the relative position change remain unchanged.

The direction change can be identified as a result of the phase voltage (r0089). When the direction reverses, then the absolute position reference is also lost.

For vector control, in addition, the output direction of rotation of the converter can be reversed using p1820. This means that the rotating field can be changed without having to interchange the power connections. If an encoder is being used, the direction of rotation must, when required, be adapted using p0410.

Note

Rotating/moving measurement for motor data identification of SERVO drives

Use parameter p1959[0...n].14/15 = 0 to activate a direction inhibit for the rotating measurement for motor data identification where necessary. The direction inhibit should be deactivated with p1959[0...n].14/15 = 1 for complete and accurate identification of the motor.

Features

- No change to the speed setpoint and actual value, the torque setpoint and actual value and the relative position change.
- Only possible when the pulses are inhibited

 WARNING
--

Danger to life as a result of an excessively high torque due to an inappropriate phase sequence of the motor after direction reversal
--

If a drive is synchronized to the line supply, when the direction is reversed, high torques can be generated when connecting to the line supply if the phase sequence of the line voltage does not match the phase sequence of the rotating motor. This high torque can destroy the coupling between the motor and load and therefore result in death or severe injury.

- | |
|--|
| <ul style="list-style-type: none">• As a consequence, for this constellation, check the phase sequence of the VSM wiring and correct if necessary. |
|--|

NOTICE**Material damage when the drive uncontrollably accelerates with an external speed actual value**

When using an external speed actual value for the speed controller via p1440, positive feedback can occur in the speed control loop. As a consequence, the drive accelerates up to its speed limit and can be damaged.

- When using external speed actual values for the speed controller, additionally change its polarity when reversing the direction of rotation (p1821 = 1).

Note**Position reference is lost at direction reversal**

If direction reversal is configured in the data set configurations (e.g. p1821[0] = 0 and p1821[1] = 1), when the function module "Basic positioner" or "Position control" is activated, the absolute adjustment is reset after each data set changeover (p2507), as the position reference is lost when the direction of rotation is switched over.

Overview of the important parameters (see SINAMICS S120/S150 List Manual)

- r0069[0...8] CO: Phase current actual value
- r0089[0...2] Phase voltage, actual value
- p1820[0...n] Reverse output phase sequence
- p1821[0...n] Direction of rotation
- p1959[0...n] Rotating measurement configuration
- p2507[0...n] Position control absolute encoder adjustment status

7.11 Automatic restart

The automatic restart function is used to automatically restart the drive / drive line-up, e.g. when the power is restored after a power failure. In this case, all of the faults present are automatically acknowledged and the drive is powered-up again. This function is not only restricted to line supply faults; it can also be used to automatically acknowledge faults and to restart the motor after any fault trips.

In order to allow the drive to be powered-up while the motor shaft is still rotating, for a "VECTOR" drive object, the "flying restart" function should be activated using p1200. Before the automatic restart commences, it must be ensured that the returning supply voltage is available and is present at the infeed.

On this subject, also note the information in Section Infeed switch on by a drive (Page 888).

Note

Automatic restart functions in servo control and vector control and for infeeds with infeed control.

After the line supply voltage is connected, Smart Line Modules 5kW/10kW automatically switch on.

When the automatic restart function is activated, then the system also restarts after the Control Unit powers up if there is still an ON signal.

If p1210 is set to the value > 1, the Line Module / motors can start automatically once the line supply has been re-established. This is especially critical if, after longer line supply failures, motors come to a standstill (zero speed) and it is incorrectly assumed that they have been powered-down.

 WARNING
Danger to life due to unexpected movement when the automatic restart function is activated
When the automatic restart is activated, when the line supply returns, unexpected motion can occur that may result in death or serious injury.
<ul style="list-style-type: none">• Take the appropriate measures on the plant/system side so that there is no safety risk as a result of an unexpected restart.

Automatic restart mode

Table 7- 7 Automatic restart mode

p1210	Mode	Meaning
0	Disables automatic restart	Automatic restart inactive
1	Acknowledges all faults without re-starting	Any faults that are present, are acknowledged automatically once the cause has been rectified. If further faults occur after faults have been acknowledged, then these are also again automatically acknowledged. A minimum time of $p1212 + 1s$ must expire between successful fault acknowledgment and a fault re-occurring if the signal ON/OFF1 (control word 1, bit 0) is at a HIGH signal level. If the ON/OFF1 signal is at a LOW signal level, the time between a successful fault acknowledgment and a new fault must be at least 1 s. For $p1210 = 1$, fault F07320 is not generated if the acknowledge attempt failed (e.g. because the faults occurred too frequently).
4	Restart after line supply failure, without additional startup attempts	An automatic restart is only carried out, if fault F30003 has also occurred at the Motor Module, or there is a high signal at binector input $p1208[1]$, or in the case of an infeed drive object (X_INF1), fault F06200 has occurred. If additional faults are pending, then these faults will also be acknowledged; if this is successful, the startup attempt will be resumed. For the case that only the phase voltage fails, time monitoring can be set using $p1213$.
6	Restart after a fault with additional startup attempts	An automatic restart is carried out after any fault or for $p1208[0] = 1$. If the faults occur one after the other, then the number of startup attempts is defined in $p1211$. Monitoring over time can be set by $p1213$.
14	Restart after line supply failure following manual acknowledgment	As for 4: However, existing faults must be acknowledged manually. This is then followed by an automatic restart.
16	Restart after a fault after manual acknowledgment	As for 6: However, existing faults must be acknowledged manually. This is then followed by an automatic restart.

Startup attempts (p1211) and wait time (p1212)

$p1211$ is used to specify the number of startup attempts. The number is internally decremented after each successful fault acknowledgment (line supply voltage must be re-applied or the infeed signals that it is ready). Fault F07320 is signaled if the number of parameterized startup attempts is exceeded.

When $p1211 = x$, $x + 1$ startup attempts are made.

Note

A startup attempt immediately starts when the fault occurs.

The faults are automatically acknowledged in intervals of half the waiting time $p1212$.

After successfully acknowledgment and the voltage returns, then the system is automatically powered-up again.

The startup attempt has been successfully completed if the flying restart and the motor magnetization (induction motor) have been completed ($r0056.4 = 1$) and one additional second has expired. The starting counter is only reset to the initial value $p1211$ after this time.

If additional faults occur between successful acknowledgment and the end of the startup attempt, then the startup counter, when it is acknowledged, is also decremented.

Monitoring time line supply return (p1213)

The monitoring time starts when the faults are detected. If the automatic acknowledgments are not successful, the monitoring time runs again. If the drive has not successfully started again after the monitoring time has expired (flying restart and motor magnetization must have been completed: r0056.4 = 1), fault F07320 is output. The monitoring is deactivated with p1213 = 0.

If p1213 is set lower than the sum of p1212, the magnetization time r0346 and the additional delay time due to flying restart, then fault F07320 is generated at each restart. p1210 = 1 prevents a restart. The monitoring time must be extended if the faults that occur cannot be immediately and successfully acknowledged (e.g. when faults are permanently present).

Commissioning

1. Activate the function for drive objects "SERVO", VECTOR or X_INF (all drive objects "Infeed"; i.e. A_INF, B_INF, S_INF).
 - Automatic restart: Set mode (p1210).
 - Flying restart (only for "VECTOR"): Activate function (p1200).
2. Set the startup attempts (p1211).
3. Set the wait times (p1212, p1213).
4. Check the function.

Exceptions

There are faults, where after they have occurred, an automatic restart would be dangerous or is undesirable. Enter the numbers of these faults into p1206[0..9]. The automatic restart is suppressed if one of these faults occurs. After the cause of the fault has been removed, the drives must be switched-on in another way.

Overview of important parameters (see SINAMICS S120/S150 List Manual)

- r0863.0...2 CO/BO: Drive coupling status word / control word
- p1206[0...9] Automatic restart fault active
- p1207 BI: Automatic restart (AR) - connection to the following drive object
- p1208[0...1] BI: Automatic restart modification, infeed
- p1210 Automatic restart mode
- p1211 Automatic restart, startup attempts
- p1212 Automatic restart, delay time startup attempts
- p1213[0...1] Automatic restart monitoring time
- r1214.0...15 CO/BO: Automatic restart status

7.12 Armature short-circuit, DC braking

The "Armature short-circuit" and "DC braking" functions can be set using parameters p1231[0...n]. The current status of the armature short-circuit or the DC braking can be seen in r1239.

Armature short-circuit

Using this function, you can brake permanent-magnet synchronous motors. The stator windings of synchronous motors are then short-circuited. For a rotating synchronous motor, a current flows that brakes the motor.

Armature short-circuit is preferably used in the following cases:

- If braking is to be performed without feedback
- If braking is to be performed when the power fails
- If an infeed unit is used that is not capable of feedback
- If with orientation loss (e.g. with encoder errors), the motor should still be braked

You can switch the armature short-circuit internally via the Motor Module or externally using a contactor circuit with braking resistors.

The advantage of armature short-circuit braking over a mechanical brake is the response time of the internal armature short-circuit braking with just a few milliseconds. The response time of a mechanical brake is about 40 ms. For external armature short-circuit braking, the slowness of the switching contactor results in a response time of over 60 ms.

DC braking

Using this function, you can brake induction motors down to standstill. With DC braking, a DC current is impressed in the stator windings of the induction motor.

DC braking is preferred in the event of danger:

- If it is not possible to ramp-down the drive in a controlled fashion
- If an infeed unit not capable of feedback is used
- If no braking resistor is used

7.12.1 Armature short-circuit braking for permanent-magnet synchronous motors

7.12.1.1 Internal armature short-circuit braking

With the internal armature short-circuit braking, the motor windings are short-circuited using the Motor Module.

Requirement

- This function has been released for Motor Modules in the booksize and chassis formats.
- Short-circuit-proof motors (p0320 < p0323)
- One of the following motor types is used:
 - rotating permanent-magnet synchronous motor (p0300 = 2xx)
 - linear permanent-magnet synchronous motor (p0300 = 4xx)
- The maximum current of the Motor Module (r0209.0) must be at least 1.8x the motor short-circuit current (r0331).

Note

Internal short-circuit braking despite power failure

If armature short-circuit braking should still be maintained despite a power failure, you must buffer the 24 V power supply for the Motor Module. For this purpose, you can use for example a dedicated SITOP unit for the Motor Module or a Control Supply Module (CSM).

Setting

The internal armature short-circuit braking is set with p1231 = 4.

Activation

The function is activated and initiated if the signal source of p1230 is set to a "1".

Deactivation

The function is deactivated if the signal source of p1230 is set to a "0". When triggered by a fault, the fault must have been removed and acknowledged.

7.12.1.2 External armature short-circuit braking

This function controls an external contactor via output terminals that then short-circuits the motor windings through resistors.

Requirement

- Short-circuit-proof motors (p0320 < p0323):
Use only short-circuit proof motors, or use suitable resistors to short-circuit the motor.
- One of the following motor types is used:
 - rotating permanent-magnet synchronous motor (p0300 = 2xx)
 - linear permanent-magnet synchronous motor (p0300 = 4xx)

Setting

The external armature short-circuit braking is activated via p1231 = 1 with contactor feedback signal or via p1231 = 2 without contactor feedback signal.

Activation

The function is activated as follows:

- The signal source is set to a "1" signal by p1230
- The pulse inhibit is set

Pulse cancellation is first activated, then the external armature short-circuit braking initiated. If the function has been triggered, r0046.4 indicates a "1".

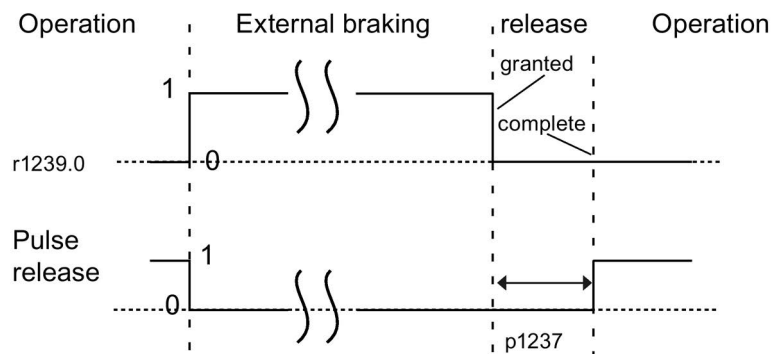

Figure 7-3 Pulse enable - signal characteristic of external armature short-circuit without contactor feedback signal

Example of an activation:

1. The signal source of p1230 is set to a "1" signal
2. As a consequence, the display parameters of drive object Motor Module r1239.0 and r0046.4 also indicate a "1".
3. Pulse enable is deleted, and the contactor for the external braking is switched.
4. Braking starts as a result of the short-circuited armature
5. Braking is terminated by setting the signal source of p1230 to a "0" (as a consequence, r1239.0 also indicates a "0" signal).
6. When the wait time p1237 expires, the pulses are enabled.

Calculating the external braking resistors

To achieve the highest braking effect, calculate the values of the resistors using the following formula:

$$R_{\text{ext}} = 5.2882 \times 10^{-5} \times p0314 \times p0356 \times n_{\text{max}} - p0350$$

n_{max} = maximum speed used

Parameterization

You can parameterize the Motor Module and the Control Unit using the STARTER commissioning tool. The expert lists of the drive objects and an input screen form to enter the digital inputs/outputs are available.

The input screen form of the Control Unit for the digital inputs/outputs DI/DO 8 to 15 is located under the "Control Unit/bidirectional digital inputs/outputs" window tab.

Terminals 11 and 14 are connected to ground.

The digital inputs/outputs DI/DO 8 to 15 are connected with terminals 9, 10, 12 and 13 at terminal blocks X122 and X132. Parameters p0728[8...15] are used to define the terminals as an input or output.

Digital inputs DI 8 to 15 are interconnected with the parameters p0722[8...15] and can be inverted with p0723[8...15].

The outputs are interconnected with parameters p0738 to p0745.

The outputs can be inverted with p0748[8...15] = 1.

Parameters p0722 to p0748 are Control Unit parameters.

Parameters p123x, r1239 and r0046 are drive parameters.

Example of external armature short-circuit braking

Before parameterizing external armature short-circuit braking, you have to create a new project with a Motor Module and a motor. The following conditions must be fulfilled:

- A short-circuit contactor with an additional feedback signal contact is used ($p1231 = 1$).
- DI 14 is defined as the input for the feedback signal of the short-circuit contactor. In the event of power failure or wire break, the motor should be operated in a safe state. The feedback signal of DI 14 is inverted for this purpose. Digital input DI 14 is connected to terminal 12 of terminal strip X132.
- DO 15 is used as switching output for the short-circuit contactor. Digital output DO 15 is connected to terminal 13 of terminal strip X132. Parameter $r1239.0$ indicates the status of the braking and issues the signal for the contactor.

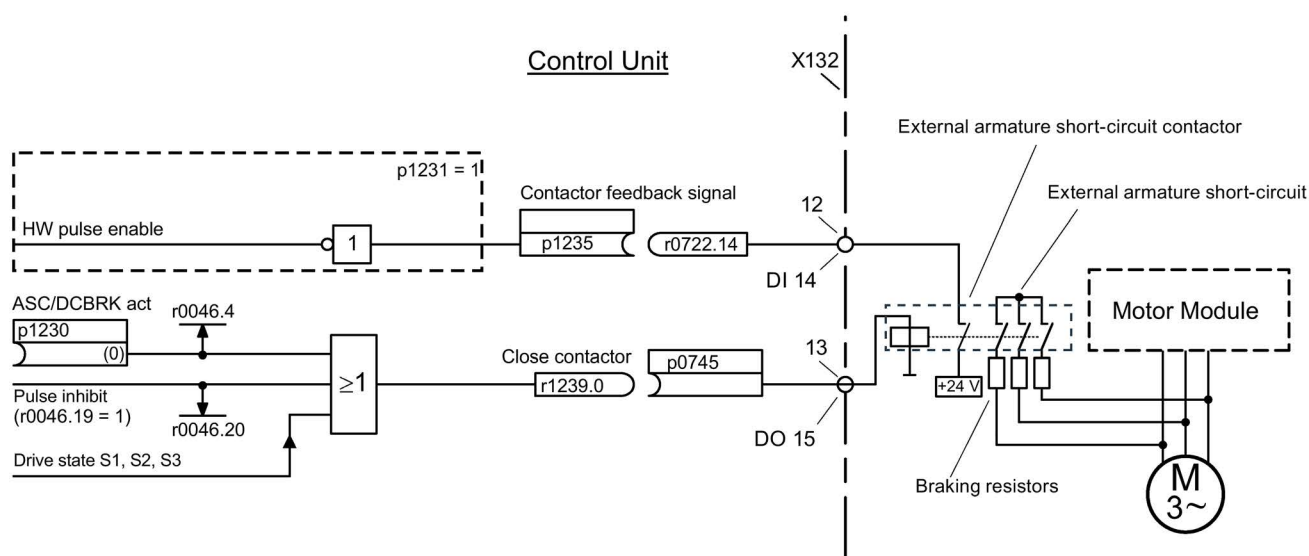

Figure 7-4 Example of external armature short-circuit braking

Parameterization of the example:

1. Set $p1231 = 1$.
2. Define DI 14 as input with $p0728.14 = 0$.
3. Connect the feedback signal of the external armature short-circuit contactor with terminal 12 of terminal strip X132 (DI 14).
4. Interconnect $p1235$ with $r0722.14$.
5. Define DO 15 as output with $p0728.15 = 1$.
6. Connect the control signal for the external armature short-circuit contactor with terminal 13 of terminal strip X132 (DO 15).
7. Interconnect $p0745$ with $r1239.0$.

The parameterization of external armature short-circuit braking has now been completed.

7.12.2 DC braking

Preconditions

- This function has been released for Motor Modules in the booksize, blocksize and chassis formats.
- An induction motor must be used.

With the function "DC braking", after a demagnetization time, a DC current is injected in the stator windings of the induction motor. The DC current brakes the motor.

7.12.2.1 Activation via parameters

Setting

DC braking is set with parameter p1231 = 4.

- Setting the braking current for DC braking with p1232[0..n]
- Setting the braking current duration for DC braking with p1233[0..n]
- Setting the start speed for DC braking with p1234[0..n]

Activation

The function is activated if the signal source of p1230 is set to "1". Initially, for the motor demagnetization time p0347[0 ... n], the pulses are inhibited until the motor is demagnetized. The DC braking start speed parameter p1234 is not taken into account with this activation.

The DC braking current p1232[0 ... n] is injected into the motor as long as a "1" signal is available at the input of p1230. The motor can be braked down to standstill.

If the drive is switched off - and DC braking is activated - the drive switches itself on. DC current is then injected into the stator windings.

Deactivation

If DC braking is deactivated by setting the signal source of p1230 to "0" and the ON command is still active, then the drive returns to its selected operating mode.

The following applies:

- For servo control (with encoder):
The drive returns to close-loop control after the demagnetization time has elapsed (p0347 can also be set to 0).
- For vector control (with and without encoder):
When the "flying restart" function is activated, the Motor Module is synchronized with the motor frequency. The drive is then switched back into closed-loop controlled operation. If the "flying restart" function is not activated, the drive can only be restarted from standstill. In this case, for a new start you must wait until the drive has come to a standstill.
- For U/f control:
When the "flying restart" function is activated, the Motor Module is synchronized with the motor frequency. The drive is then switched back to U/f control. If the "flying restart" function is not available, the drive can only be restarted from standstill. In this case, for a new start you must wait until the drive has come to a standstill.

7.12.2.2 Activation via fault response

If DC braking is activated as fault response, then the following responses are executed:

1. The motor is braked along the braking ramp up to the threshold in p1234. The gradient of the braking ramp corresponds to the gradient of the down ramp (can be set using p1121).
2. The pulses are inhibited for the duration of the motor demagnetization time (p0347) until the magnetic field in the motor has decayed.
3. After p0347 has expired, DC braking starts for the period of time according to p1233. If an encoder is being used, the braking operation lasts until the speed falls below the zero speed threshold set in p1226. If an encoder is not being used, braking lasts until the time set in p1233 has expired.

Note

For encoderless servo control, it is possible that operation cannot be continued after DC braking has been completed. An OFF2 fault response is then output.

7.12.2.3 Activation via OFF fault responses

Setting as a response to OFF fault signals

With $p1231 = 5$, DC braking is set as a response to OFF1 or OFF3. Parameter $p1230$ has no influence on the response for OFF1/OFF3. The speed threshold is set with $p1234$, under which DC braking is activated.

Activation using OFF1/OFF3

DC braking is activated with OFF1 or OFF3.

- If the motor speed $\geq p1234$, the motor is braked down to $p1234$. As soon as the motor speed is $< p1234$, the pulses are disabled and the motor is demagnetized.
- If the motor speed at OFF1/OFF3 is already $< p1234$, the pulses are immediately inhibited and the motor is demagnetized.

DC braking is then activated for the duration $p1233$ and is then switched off.

When OFF1/OFF3 is prematurely canceled, then normal operation is resumed.

DC braking as emergency braking of a fault response remains active.

7.12.2.4 Activation via a speed threshold

Setting

If $p1231$ is set to 14, DC braking as a response is activated as soon as the actual speed falls below $p1234$.

Activation

Before activation, the actual speed must be $> p1234$. DC braking can then be activated when both of the following conditions are met:

- The actual speed has fallen below $p1234$.
- The signal source of $p1230$ is set to "1".

The pulses are first disabled. As a consequence, the motor is demagnetized. DC braking is then initiated for the duration $p1233$. The motor is braked with the braking current $p1232$.

If the signal source of $p1230$ is set to "0", the braking command is canceled and the drive goes back into the previous operating mode.

DC braking for OFF1 or OFF3 is only executed if the signal source of $p1230$ is set to "1".

DC braking as emergency braking of a fault response remains active.

7.12.3 Configuring the fault response

Changing the fault response

The responses can be set to selected faults using parameters p2100 and p2101. Only responses can be set that are intended for the corresponding faults.

Using parameter p0491, responses to encoder errors of a motor encoder can be set (F07412 and many F3yxxx, y = 1, 2, 3).

Note**Motor type change**

If the preconditions for armature short-circuit braking or DC braking are no longer satisfied after a motor type has been changed (see p0300), then those modified parameters that have armature short-circuit braking or DC braking as a response (e.g. p2100, p2101 or p0491) are set to the factory setting.

Note**Deselecting armature short-circuit or DC braking**

Armature short-circuit or DC braking cannot be deactivated using parameter p1231, as long as a response parameterized with p2100, p2101 or p0491 has a fault condition.

7.12.4 Function diagrams and parameters

Function diagrams (see SINAMICS S120/S150 List Manual)

- 7014 Technology functions - External armature short circuit (EASC, p0300 = 2xx or 4xx)
- 7016 Technology functions - Internal armature short-circuit (IVP, p0300 = 2xx or 4xx)
- 7017 Technology functions - DC braking (p0300 = 1xx)

Overview of important parameters (see SINAMICS S120/S150 List Manual)

- r0046.0...31 CO/BO: Missing enable signals
- p0300[0...n] Motor type selection
- p0347[0...n] Motor de-excitation time
- p0491 Motor encoder fault response: ENCODER
- r0722.0...21 CO/BO: CU digital inputs, status
- r0723.0...21 CO/BO: CU digital inputs, status inverted
- p0728 CU set input or output
- p0738 BI: CU signal source for terminal DI/DO 8
- To
- p0745 BI: CU signal source for terminal DI/DO 15
- p0748 CU, invert digital outputs
- p1226[0...n] Standstill recognition speed threshold
- p1230[0...n] BI: Armature short-circuit/DC braking activation
- p1231[0...n] Armature short-circuit/DC braking configuration
- p1232[0...n] DC braking, braking current
- p1233[0...n] DC braking duration
- p1234[0...n] Speed at the start of DC braking
- p1235[0...n] BI: External armature short-circuit, contactor feedback signal
- p1237[0...n] External armature short-circuit, delay time when opening
- r1239.0...13 CO/BO: Armature short-circuit/DC braking status word

7.13 Motor Module as a Braking Module

This function uses a Motor Module as a Braking Module. To do this, three resistors are connected to the Motor Module instead of a motor.

Requirements for operation as a Braking Module:

- Three identical braking resistors in a star (see table below) or delta connection
- At least 10 m cable length to the resistors
- Configuration in STARTER
 - VECTOR drive object
 - V/f control

Note

This function is released for:

- SINAMICS S120 Motor Modules Cabinet
 - SINAMICS S120 Motor Modules Chassis (500 V - 690 V)
 - SINAMICS S120 Motor Modules Chassis (380 V - 480 V) > 250 kW
 - SINAMICS S120 Motor Modules Chassis Liquid Cooled (380 V - 480 V) > 250 kW
 - SINAMICS S120 Motor Modules Chassis Liquid Cooled (500 V - 690 V)
-

7.13.1 Features

- Three identical resistors required
- Parallel connection of Motor Modules possible
- Integrated protective devices are available for monitoring the resistors
- The chassis Motor Module must be switched on in order that it can operate as Braking Module

7.13.2 Configuring resistors

Rules and values

- Under no circumstances may the resistance values for the peak braking power, which are listed in this table, be fallen below!
- The resistance values apply for each of the three resistors in a star connection in the cold state.
- Each braking resistor absorbs 1/3 of the total braking power. It is imperative that you take into account the power rating of the resistors.

7.13 Motor Module as a Braking Module

- For a delta connection, multiply the braking resistance value by a factor of 3.
- The tables apply for all Motor Modules of the "chassis" format (liquid or air cooling).
- The cable lengths to the resistors must be at least 10 m.
- At rated voltages of 380 V to 480 V, Motor Modules with a type rating ≥ 250 kW are permitted.
- At rated voltages of 500 V to 690 V, all Motor Modules in the "chassis" format have been released for use of this function.

You can enter the resistance value in a star connection into parameter p1360. The default setting of the resistance values is calculated from:

- $p1360 = p1362[0] / (\sqrt{6}) * r0207[0]$
- $p1362[0]$ = Braking Module activation threshold according to the following table.
- $r0207[0...4]$ = rated current of the Motor Module

Table 7- 8 Resistance table 380 - 480 V supply voltage

Motor Module frame size	Rated voltage	Rated current	Braking current	U _{DC link} chopper threshold	Continuous braking power	Peak braking power	Resistance at the continuous braking power	Resistance at the peak braking power
	[V]	[A]	[A]	[V]	[kW]	[kW]	[Ω]	[Ω]
G	400	490	450	667	368	551	0.605	0.403
	480	490	450	774	427	640	0.702	0.466
H	400	605	545	667	445	668	0.500	0.333
	480	605	545	774	517	775	0.580	0.387
H	400	745	680	667	555	833	0.400	0.267
	480	745	680	774	645	967	0.465	0.310
H	400	840	800	667	654	980	0.340	0.277
	480	840	800	774	758	1138	0.395	0.263
J	400	985	900	667	735	1103	0.303	0.202
	480	985	900	774	853	1280	0.351	0.234
J	400	1260	1215	667	93	1489	0.224	0.149
	480	1260	1215	774	1152	1728	0.260	0.173
J	400	1405	1365	667	1115	1673	0.199	0.133
	480	1405	1365	774	1294	1941	0.231	0.154

Table 7- 9 Resistance table 500 - 690 V supply voltage

Motor Module frame size	Rated voltage	Rated current	Braking current	U _{DC link} chopper threshold	Continuous braking power	Peak braking power	Resistance at the continuous braking power	Resistance at the peak braking power
	[V]	[A]	[A]	[V]	[kW]	[kW]	[Ω]	[Ω]
F	500	85	85	841	87.6	131.3	4.039	2.693
	600	85	85	967	100.7	151.0	4.644	3.096
	660	85	85	1070	111.4	167.1	5.139	3.426
	690	85	85	1158	120.6	180.8	5.562	3.708
F	500	100	100	841	103.0	154.5	3.433	2.289
	600	100	100	967	118.4	177.6	3.948	2.632
	660	100	100	1070	131.0	196.6	4.368	2.912
	690	100	100	1158	141.8	212.7	4.728	3.152
F	500	120	115	841	118.5	177.7	2.986	1.990
	600	120	115	967	136.2	204.3	3.433	2.289
	660	120	115	1070	150.7	226.1	3.798	2.532
	690	120	115	1158	163.1	244.6	4.111	2.741
F	500	150	144	841	148.3	222.5	2.384	1.590
	600	150	144	967	170.5	255.8	2.742	1.828
	660	150	144	1070	188.7	283.1	3.034	2.022
	690	150	144	1158	204.2	306.3	3.283	2.189
G	500	175	175	841	180.3	270.4	1.962	1.308
	600	175	175	967	207.3	310.9	2.256	1.504
	660	175	175	1070	229.3	344.0	2.496	1.664
	690	175	175	1158	248.2	372.3	2.701	1.801
G	500	215	215	841	221.5	332.2	1.597	1.065
	600	215	215	967	254.6	381.9	1.836	1.224
	660	215	215	1070	281.8	422.6	2.032	1.354
	690	215	215	1158	304.9	457.4	2.199	1.466
G	500	260	255	841	262.7	394.0	1.346	0.898
	600	260	255	967	302.0	453.0	1.548	1.032
	660	260	255	1070	334.2	501.3	1.713	1.142
	690	260	255	1158	361.7	542.5	1.854	1.236
G	500	330	290	841	298.7	448.1	1.184	0.789
	600	330	290	967	343.5	515.2	1.361	0.908
	660	330	290	1070	380.0	570.1	1.506	1.004
	690	330	290	1158	441.3	616.9	1.630	1.087
H	500	410	400	841	412.0	618.0	0.858	0.572
	600	410	400	967	473.7	710.6	0.987	0.658
	660	410	400	1070	524.2	786.3	1.092	0.728
	690	410	400	1158	567.3	851.0	1.182	0.788

7.13 Motor Module as a Braking Module

Motor Module frame size	Rated voltage	Rated current	Braking current	U _{DC link} chopper threshold	Continuous braking power	Peak braking power	Resistance at the continuous braking power	Resistance at the peak braking power
	[V]	[A]	[A]	[V]	[kW]	[kW]	[Ω]	[Ω]
H	500	465	450	841	463.5	695.3	0.763	0.509
	600	465	450	967	532.9	799.4	0.877	0.585
	660	465	450	1070	589.7	884.6	0.971	0.647
	690	465	450	1158	638.2	957.3	1.051	0.700
H	500	575	515	841	530.5	795.7	0.667	0.444
	600	575	515	967	609.9	914.9	0.767	0.511
	660	575	515	1070	674.9	1012.3	0.848	0.565
	690	575	515	1158	730.4	1095.6	0.918	0.612
J	500	735	680	841	700.4	1050.6	0.505	0.337
	600	735	680	967	805.3	1208.0	0.581	0.387
	660	735	680	1070	891.1	1336.7	0.642	0.428
	690	735	680	1158	964.4	1446.6	0.695	0.463
J	500	810	805	841	829.2	1243.7	0.427	0.284
	600	810	805	967	953.4	1430.1	0.490	0.327
	660	810	805	1070	1054.9	1582.4	0.543	0.362
	690	810	805	1158	1141.7	1712.5	0.587	0.392
J	500	910	905	841	932.2	1398.2	0.379	0.253
	600	910	905	967	1071.8	1607.7	0.436	0.291
	660	910	905	1070	1186.0	1779.0	0.483	0.322
	690	910	905	1158	1283.5	1925.3	0.522	0.348
J	500	1025	1020	841	1050.6	1575.9	0.337	0.224
	600	1025	1020	967	1280.0	1812.0	0.387	0.258
	660	1025	1020	1070	1336.7	2005.0	0.428	0.286
	690	1025	1020	1158	1446.6	2169.9	0.463	0.309
J	500	1270	1230	841	1266.9	1900.4	0.279	0.186
	600	1270	1230	967	1456.7	2185.1	0.321	0.214
	660	1270	1230	1070	1611.9	2417.8	0.355	0.237
	690	1270	1230	1158	1744.5	2616.7	0.384	0.256

Connecting braking resistors

Preferably connect the braking resistors in a star configuration

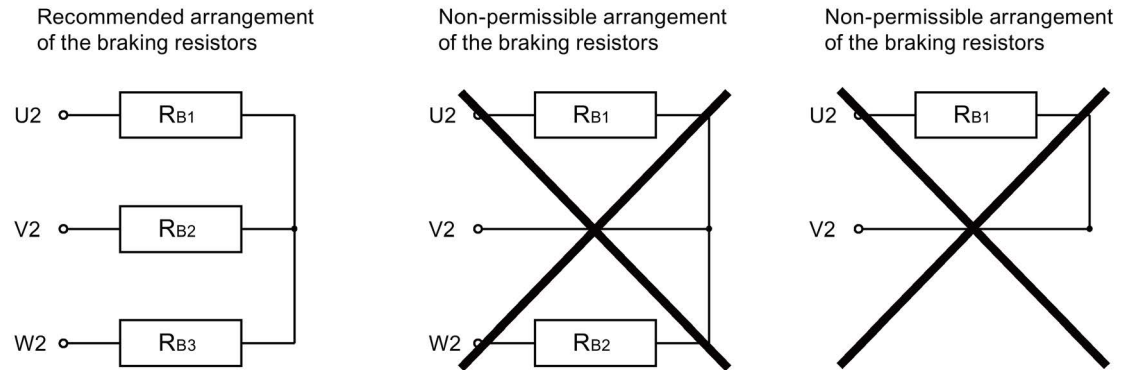

Figure 7-5 Braking resistors

Setting of the Braking Module activation threshold

The value of the Braking Module activation threshold p1362[0] and the hysteresis p1362[1] can be adjusted. Depending on the voltage type, the parameters are assigned different values depending on the factory setting of p0210.

Table 7- 10 Activation threshold

Line supply voltage	V	380 - 480	500 - 600	660 - 690
Tolerance	%	+/- 10%, -15% (60 s)	+/- 10%, -15% (60 s)	+/- 10%, -15% (60 s)
U _{dmax}	V	820	1022	1220
U _{DC link}	V _{min}	759	948	1137
Braking Module activation threshold p1362[0]	V _{rated}	774	967	1159
	V _{max}	789	986	1179
HW shutdown threshold	V _{min}	803	1003	1198
	V _{rated}	819	1022	1220
	V _{max}	835	1041	1244

7.13.3 Activating the "Braking Module" function

You have opened the STARTER commissioning tool and created a new project or opened an existing project.

Activating the Braking Module

1. Configure the Control Unit and the infeed module as usual (see SINAMICS S120 Commissioning Manual).
2. Select "Vector" as drive object type.
3. "V/f control" should be selected as controller structure.
4. Under "Control mode", select "(15) Operation with braking resistor".
5. Select the supply voltage in the configuration dialog box.
6. In the configuration dialog box, select "Chassis" as format.
7. Select the required power unit in the configuration dialog box.
8. Close the Configuration window for the Motor Module and the resistors.
9. Follow the wizard from "Continue >" up to "Complete".

The Motor Module is displayed with the component number in the topology.

Activating a parallel connection

Motor Modules can be operated Braking Modules a in parallel connection. The setting is made in STARTER as follows during the configuration:

1. Activate the "Parallel connection" checkbox in the "Power Unit Additional Data" configuration dialog box (see step 7 of the above list).

The pull-down menu for the "Number of parallel modules" appears.

2. Select the desired number of Motor Modules.
3. Click "Continue" until you reach "Complete".

You have now completed the wizard for the configuration of the Motor Modules.

4. Check the number of Motor Modules that you have set in the topology.

The braking resistors must be dimensioned for each Motor Module according to the table of resistances above.

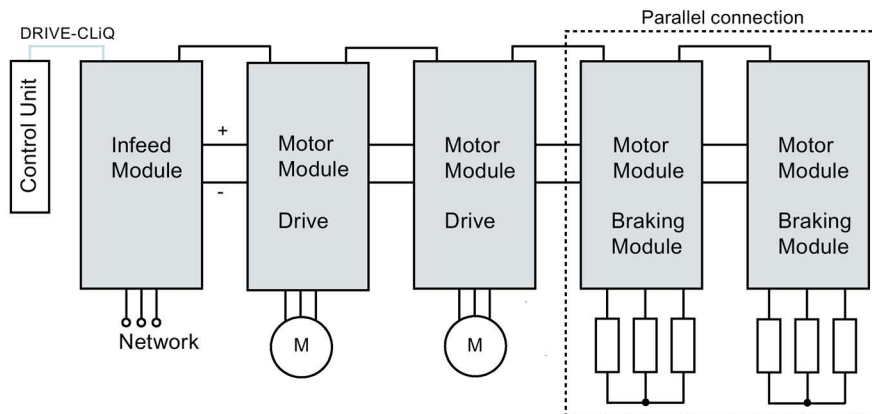

Figure 7-6 Parallel connection of Motor Modules as Braking Modules

5. To carry out further checks, double-click ".../Drives/Drive_1 > Configuration" in the project navigator.

A dialog opens allowing you to check the current configuration. The "Current power unit operating values" button lists the Motor Modules according to component number. During operation, they show the current electrical values.

Operating a parallel connection in master/slave mode

Motor Modules connected in parallel can also be operated in master/slave mode.

1. To do this, use parameter p1330 to transfer the input of the V/f characteristic to the next power unit.

The slaves only receive the voltage setpoint for the V/f characteristic.

7.13.4 Protective equipment

The protection functions are explained in detail in Section Thermal monitoring and overload responses (Page 600). Additional protective devices include:

- Ground fault

Monitoring of sum of all phase currents.

- Cable break

An unbalanced load of 20% and more produces a non-symmetrical current, which is detected by the I*T monitoring.

- Alarm A06921 is output if phase non-symmetry is detected.
- The errors are located in parameter r0949:
Parameter r0949 = 11 Wire break phase U
Parameter r0949 = 12 Wire break phase V
Parameter r0949 = 13 Wire break phase W
- Fault F06922 is output if phase failure is detected.

- Overcurrent

The I_{max} controller is active. The setpoint is stored in parameter p0067.

- Overtemperature of the resistors

The temperature is monitored using bimetal temperature switches mounted on the resistors.

Configuring temperature evaluation contacts

1. Switch the temperature evaluation contacts of all 3 resistors in series.
2. Connect the temperature evaluation contacts to the temperature sensor evaluation of the Motor Module (terminals X41.3 and X41.4).
3. For the temperature monitoring, set the temperature sensor via Motor Module (p0600 = 11).
4. Set sensor type "Bimetallic NC contact warning & timer" as motor temperature sensor (p0601 = 4).
5. Parameterize the temperature sensor evaluation of the Motor Module as "external fault".

7.13.5 Overview of the important parameters

Overview of important parameters (see SINAMICS S120/S150 List Manual)

- r0207[0...4] Rated power unit current
- r0949[0...63] Fault value
- p1300[0...n] Open-loop/closed-loop control operating mode
- p1330[0...n] CI: V/f control independent of voltage setpoint
- p1360 Braking Module braking resistor, cold
- p1362[0...1] Braking Module activation threshold
- r1363 CO: Braking Module output voltage
- p1364 Braking Module non-symmetrical resistance

7.14 OFF3 torque limits

If the torque limits are externally specified (e.g. tension controller), then the drive can only be stopped with a reduced torque. If stopping in the selected time p3490 of the infeed has not been completed, the infeed shuts down and the drive coasts down.

In order to avoid this, there is a binector input (p1551), that for a LOW signal, activates the torque limits p1520 and p1521. This means that the drive can brake with the maximum torque by interconnecting the signal OFF 3 (r0899.5) to this binector.

Function diagrams (see SINAMICS S120/S150 List Manual)

- 5620 Servo control - Motoring/generating torque limit
- 5630 Servo control - Upper/lower torque limit
- 6630 Vector control - Upper/lower torque limit

Overview of important parameters (see SINAMICS S120/S150 List Manual)

- p1520[0...n] Torque limit, upper/motoring
- p1521[0...n] CO: Torque limit, lower/regenerative

7.15 Technology function friction characteristic

The friction characteristic curve is used to compensate the friction torque for the motor and the driven machine. A friction characteristic enables the speed controller to be precontrolled and improves the response.

Ten interpolation points are used for each friction characteristic curve. The coordinates of every interpolation point are defined by a speed parameter (p382x) and a torque parameter (p383x) (point 1 = p3820 and p3830).

Features

- Ten interpolation points are available for mapping the friction characteristic curve.
- An automatic function allows you to record the friction characteristic curve (record friction characteristic curve).
- A connector output (r3841) can be applied as friction torque (p1569).
- The friction characteristic can be activated and deactivated (p3842).

Commissioning via parameters

In p382x, speeds for the measurement are predefined as a function of the maximum speed p1082 during first commissioning. They can be changed appropriately.

The automatic friction characteristic plot can be activated using p3845. The characteristic is then plotted the next time that it is enabled.

The following settings are possible:

- p3845 = 0 Friction characteristic curve recording deactivated
- p3845 = 1 Friction characteristic curve recording activated, all directions of rotation
The friction characteristic curve is recorded in both directions of rotation. The results of the positive and negative measurement are averaged and entered in p383x.
- p3845 = 2 Friction characteristic curve recording activated, positive direction of rotation
- p3845 = 3 Friction characteristic curve recording activated, negative direction of rotation

When the friction characteristic is plotted, the drive can cause the motor to move. As a result, the motor may reach maximum speed.

WARNING

Danger to life as a result of motor movement when plotting the friction characteristic

Motor movement caused when plotting the friction characteristic can result in death, severe injury or material damage.

- Ensure that nobody is in the hazardous zone - and that the mechanical system can freely move.

Commissioning via STARTER

In STARTER, the friction characteristic curve can be started up via the dialog under "Functions".

Function diagrams (see SINAMICS S120/S150 List Manual)

- 5610 Servo control – torque limiting/reduction, interpolator
- 6710 Vector control - Current setpoint filter
- 7010 Technology functions - Friction characteristic

Overview of important parameters (see SINAMICS S120/S150 List Manual)

- p3820[0...n] Friction characteristic, value n0
- ...
- p3839[0...n] Friction characteristic, value M9
- r3840.0...8 CO/BO: Friction characteristic status word
- r3841 CO: Friction characteristic curve output
- p3842 Activate friction characteristic
- p3843[0...n] Friction characteristic smoothing time friction moment difference
- p3844[0...n] Friction characteristic number changeover point at the top
- p3845 Activate friction characteristic plot
- p3846[0...n] Friction characteristic plot ramp-up/ramp-down time
- p3847[0...n] Friction characteristic plot warm-up period

7.16 Simple brake control

The "Simple brake control" is used exclusively for the control of holding brakes. The holding brake is used to secure drives against unwanted motion when deactivated.

The trigger command for releasing and applying the holding brake is transmitted via DRIVE-CLiQ from the Control Unit, which monitors and logically connects the signals to the system-internal processes, directly to the Motor Module.

The Motor Module then performs the action and activates the output for the holding brake. The exact sequence control is shown in function diagrams 2701 and 2704 (see SINAMICS S120/S150 List Manual). The operating principle of the holding brake can be configured via parameter p1215.

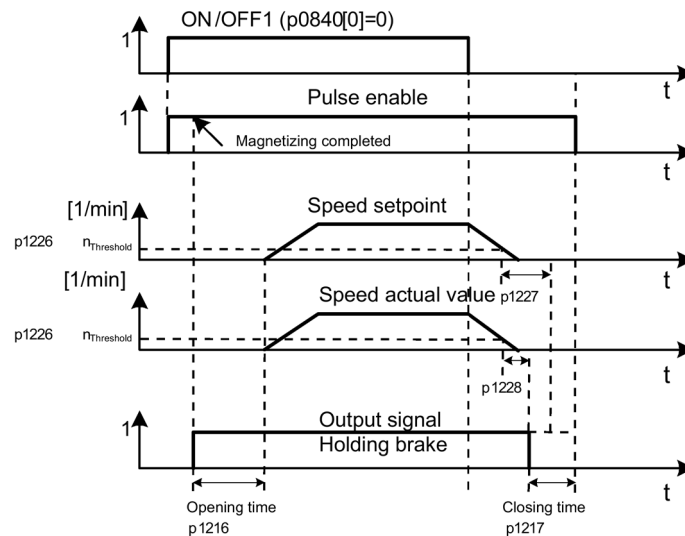

Figure 7-7 Sequence diagram, simple brake control

The start of the closing time for the brake depends on the expiration of the shorter of the two times p1227 (standstill detection monitoring time) and p1228 (pulse cancellation delay time).

Features

- Automatic activation by means of sequence control
- Standstill monitoring
- Forced brake release (p0855, p1215)
- Closing of brake for a 1 signal "unconditionally close holding brake" (p0858)
- Closing of brake after "Enable speed controller" signal has been canceled (p0856)

Commissioning

Simple brake control is activated automatically (p1215 = 1) when the Motor Module has an internal brake control and a connected brake has been found.

If no internal brake control is available, the control can be activated using a parameter (p1215 = 3).

⚠ WARNING**Danger as a result of a damaged holding brake caused by incorrect parameterization**

If the drive moves against the closed holding brake, this can destroy the holding brake and as a consequence result in death or severe injury.

- If a holding brake is being used, do **not** set p1215 = 0.
- Correctly set all of the parameters involved.

Note

It is only permissible to activate brake control monitoring for booksize power units and blocksize power units with Safe Brake Relay (p1278 = 0).

Function diagrams (see SINAMICS S120/S150 List Manual)

- 2701 Brake control - Simple brake control (r0108.14 = 0)
- 2704 Brake control - Extended brake control, standstill detection (r0108.14 = 1)

Overview of important parameters (see SINAMICS S120/S150 List Manual)

- r0056.4 CO/BO: Status word, closed-loop control; magnetizing complete
- r0060 CO: Speed setpoint before the setpoint filter
- r0063 CO: Actual velocity value smoothed
- r0063[0...2] CO: Actual speed value
- r0108.14 Drive object function module; extended brake control
- p0855[0...n] BI: Unconditionally open holding brake
- p0856[0...n] BI: Speed controller enabled
- p0858[0...n] BI: Unconditionally close holding brake
- r0899.12 CO/BO: Status word, sequence control; holding brake open
- r0899.13 CO/BO: Status word, sequence control; close holding brake command
- p1215 Motor holding brake configuration
- p1216 Motor holding brake opening time
- p1217 Motor holding brake closing time
- p1226[0...n] Threshold for standstill detection
- p1227 Standstill detection monitoring time
- p1228 Pulse suppression delay time
- p1278 Brake control diagnostics evaluation

7.17 Runtime (operating hours counter)

Total system runtime

The total system runtime is displayed in p2114 (Control Unit). Index 0 indicates the system runtime in milliseconds after reaching 86,400,000 ms (24 hours), the value is reset. Index 1 indicates the system runtime in days.

The counter value is saved when the power is switched off.

After the drive unit has been switched on, the counter continues to run with the value stored when the power was last switched off.

Relative system runtime

The relative system runtime after the last POWER ON is displayed in p0969 (Control Unit). The value is in milliseconds and the counter overflows after 49 days.

Actual motor operating hours

The motor operating hours counter p0650 (drive) is started when the pulses are enabled. When the pulse enable is withdrawn, the counter is stopped and the value saved.

If p0651 is at 0, the counter is deactivated.

If the maintenance interval set in p0651 is reached, alarm A01590 is triggered. Once the motor has been maintained, the maintenance interval must be reset.

Note

If the motor data set is switched during the star/delta changeover without the motor being changed, the two values in p0650 must be added to determine the correct number of motor operating hours.

Operating hours counter for the fan

The operating hours of the fan in the power unit are displayed in p0251 (drive).

The number of hours operated can only be reset to 0 in this parameter (e.g. after a fan has been replaced). The service life of the fan is entered in p0252 (drive). Alarm A30042 is output 500 hours before this figure is reached. Monitoring is deactivated when p0252 = 0.

Time stamp mode

The mode for the time stamp can be set via parameter p3100.

Setting	Explanation
p3100 = 0	Time stamp based on operating hours
p3100 = 1	Time stamp UTC format
p3100 = 2	Time stamp operating hours + 01.01.2000 As of Firmware V4.7: With this setting the value in p3102 is used as the time stamp for the error messages. For firmware versions prior to V4.7 the time basis of p2114 was used with the setting p3100 = 0.

Note

Time stamp settings depending on the firmware version

If a project is upgraded from firmware V4.6 to V4.7 then the time stamp settings for the old project are retained. The times displayed for the error messages do not therefore differ from those in the old firmware version.

If a new project is created in firmware version V4.7 and above, the factory setting for the p3100 = 2 and therefore a different time basis for error messages. If the behavior desired is the one for older versions than V4.7 then p3100 = 0 should be set.

Note

Synchronizing time stamps

If a control system and several drive devices are connected through a bus, then the different time stamps can be synchronized to the time stamp of the control system (=time master). Detailed information is provided in Chapter Time synchronization between the control and converter (Page 880).

7.18 Energy-saving display

Through the tailored, speed-controlled operation, a drive can consume significantly less energy than with a conventional closed-loop process control. This is especially true for continuous-flow machines with parabolic load characteristics, such as centrifugal pumps and fans. Using the SINAMICS S120 system enables control of the flow rate or the pressure by changing the speed of the continuous-flow machine. As a consequence, the plant or system is controlled close to its maximum efficiency over the complete operating range.

Energy savings display

The energy saved is displayed in r0041.

Machines with a lower energy-saving potential

When compared to continuous-flow machines with parabolic load characteristic, machines with a linear or constant load characteristic, such as conveyor drives or reciprocating pumps, have a lower energy-saving potential.

This function is optimized for fluid-flow machines.

Situation

In a conventionally controlled plant or system, the flow rate of the medium is controlled using valves or throttles. In this case, the drive motor operates at a constant rated speed defined by the particular operation. The system efficiency decreases significantly if the flow rate is reduced by means of valves or throttles. The pressure in the system increases. The motor also consumes energy when the valves/throttles are completely closed, i.e. with a flow rate of $Q = 0$. In addition, undesirable process-related situations can occur; for example, cavitation in the continuous-flow machine or increased heating of the continuous-flow machine and the medium.

Solution to optimize the system

When using a speed controller, the process-specific flow rate of the continuous-flow machine is controlled by varying the speed. The flow rate changes proportionally with the speed of the continuous-flow machine. Any throttles or valves remain completely open. The entire plant/system characteristic is shifted by the speed controller to achieve the required flow rate. As a consequence, the complete system operates close to the optimum efficiency - and especially in the partial load range, uses significantly less energy than when using a throttle or valve to control the flow rate.

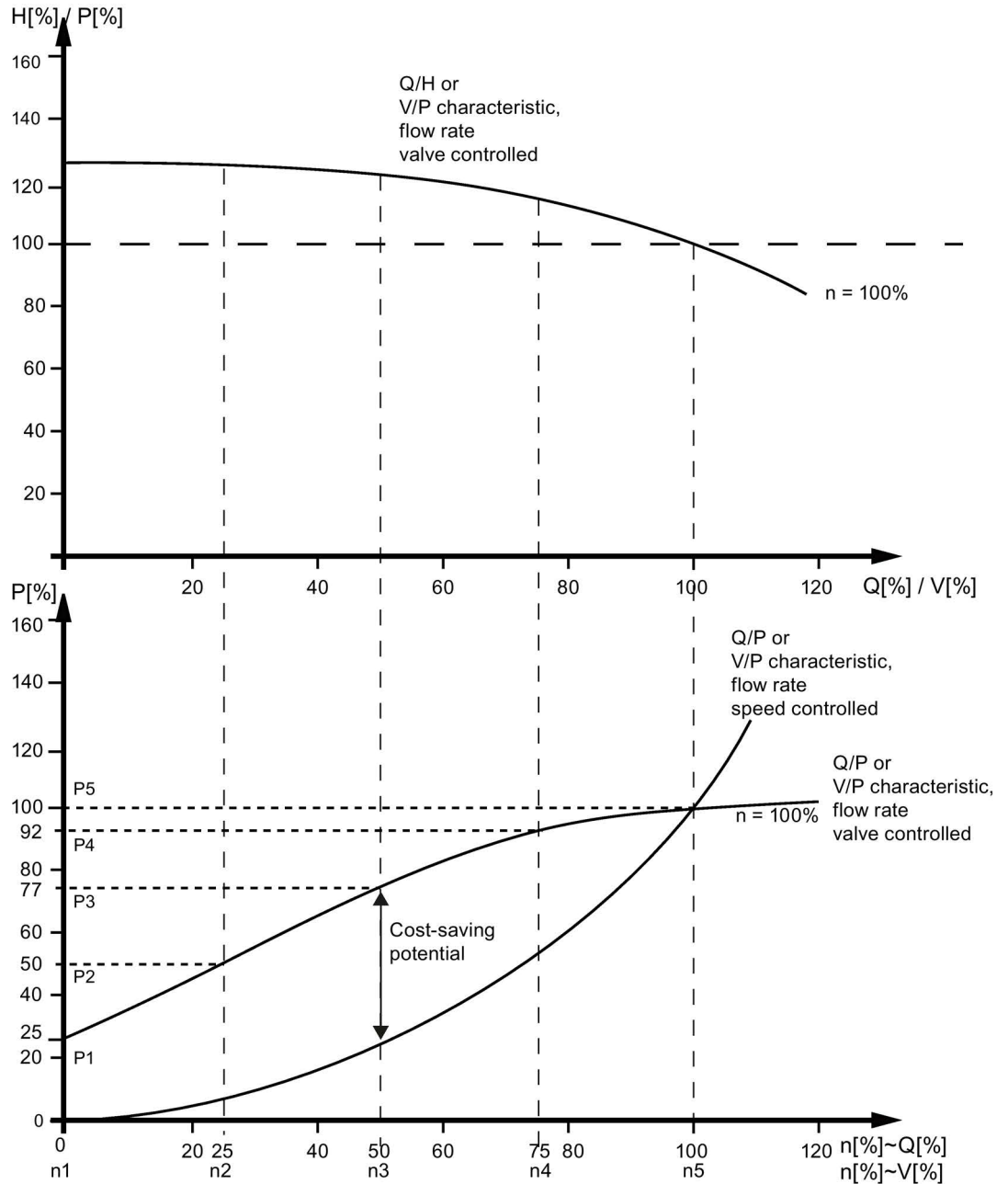

Upper characteristic:

H[%]: Delivery height, P[%]: Delivery pressure, Q[%]: Delivery rate, V[%]: Flow rate

Lower characteristic:

P[%]: Power drawn by the conveyor machine, n[%]: Speed of the conveyor machine

Interpolation points p3320 ... p3329 for the system characteristic with n = 100%:

P1 ... P5: Power drawn, n1 ... n5: Speed corresponding to a closed-loop speed control machine

Figure 7-8 Energy-saving potential

Energy-saving function

This function determines the amount of energy used and compares it with the interpolated energy required for a plant or system equipped with a conventional throttle control. The amount of energy saved is calculated over the last 100 operating hours and is displayed in kW. For an operating time of less than 100 hours, the potential energy-saving is interpolated up to 100 operating hours. To do this, you must manually enter the plant/system characteristic with the conventional throttle control.

Note

Plant/system characteristic

The factory setting is used as basis for the calculation if you do not enter the interpolation points for your plant/system characteristic. The values of the factory setting can deviate from your plant/system characteristic and result in an inaccurate calculation.

This calculation is configurable individually for each individual axis.

Activation of the function

This function is enabled only for vector mode.

- The function is automatically activated after the pulses have been enabled
- Enter five interpolation points for the load characteristic in parameters p3320 to p3329:

Table 7- 11 Plant/system interpolation points

Interpolation point	Parameter	Factory setting: P - power in % n - speed in %
1	p3320	P1 = 25.00
	p3321	n1 = 0.00
2	p3322	P2 = 50.00
	p3323	n2 = 25.00
3	p3324	P3 = 77.00
	p3325	n3 = 50.00
4	p3326	P4 = 92.00
	p3327	n4 = 75.00

Interpolation point	Parameter	Factory setting: P - power in % n - speed in %
5	p3328	P5 = 100.00
	p3329	n5 = 100.00

Reset the energy display

Set p0040 = 1, to reset the value of parameter r0041 to 0. Parameter p0040 is then automatically set back to 0.

7.19 Encoder diagnostics

7.19.1 Datalogger

A datalogger is available to support troubleshooting; this datalogger can localize errors in the encoder evaluation.

Commissioning

1. Set parameter p0437.0 = 1 to activate this function.

The datalogger is automatically active as soon as the current controller time is slower than 125 μ s.

Principle of operation

The datalogger reads out several internal signals of the encoder evaluation, which serve as basis for the actual value generation. A change in the fault state serves as trigger for the recording. Data is recorded a short time before the fault state as well as afterwards.

The diagnostics data is saved on the memory card in the following directories:

```
/USER/SINAMICS/DATA/SMTRC00.BIN
```

...

```
/USER/SINAMICS/DATA/SMTRC07.BIN
```

```
/USER/SINAMICS/DATA/SMTRCIDX.TXT
```

The following information is contained in the index file (SMTRCIDX.TXT):

- Displaying the last written BIN file
- Number of still possible write operations (from 10000 downwards).

Note

BIN files can only be evaluated by Siemens.

Alarm A3x930¹⁾ is output while diagnostics data is being actively recorded. Do not switch off the system during this time.

¹⁾ x = encoder number (x = 1, 2 or 3)

7.19.2 Encoder dirty signal

Some encoders have an additional output, which switches from "high" to "low", if the evaluation electronics in the encoder can no longer determine a reliable position.

In order to inform you about this, the drive only outputs alarm A3x470¹⁾ when an SMC30 is used.

¹⁾ x = encoder number (x = 1, 2 or 3)

Commissioning

Connect the corresponding encoder signal with the CTRL input (monitoring signal) of the device (terminal X521:7). Parameterization is not required.

Note

The input is automatically set to a high level if a wire is broken: As a consequence, for a broken wire, the encoder is considered to be "good".

Overview of important parameters (see SINAMICS S120/S150 List Manual)

- p0437[0...n] Sensor Module extended configuration

7.20 Tolerant encoder monitoring

The tolerant encoder monitoring offers the following expanded functionality regarding the evaluation of encoder signals:

- Encoder track monitoring (Page 348)
- Zero mark tolerance (Page 349) (also for other sensor modules)
- Freeze speed raw value (Page 349)
- Adjustable hardware filter (Page 350)
- Edge evaluation of the zero mark (Page 351)
- Pole position adaptation (Page 352)
- Pulse number correction for faults (Page 353)
- Monitoring, tolerance band, pulse number (Page 354)
- Expansion of the encoder evaluation (1x, 4x) (Page 355)
- Setting the measuring time to evaluate speed "0" (Page 356)
- The number of current controller cycles can be set to generate the average value of the speed actual value (Page 356)

These supplementary functions allow you to improve the evaluation of your encoder signals. This may be necessary in special cases where the Control Unit receives incorrect encoder signals or specific properties of the signals must be compensated for.

Some of these supplementary functions can be combined with one another.

Terminology

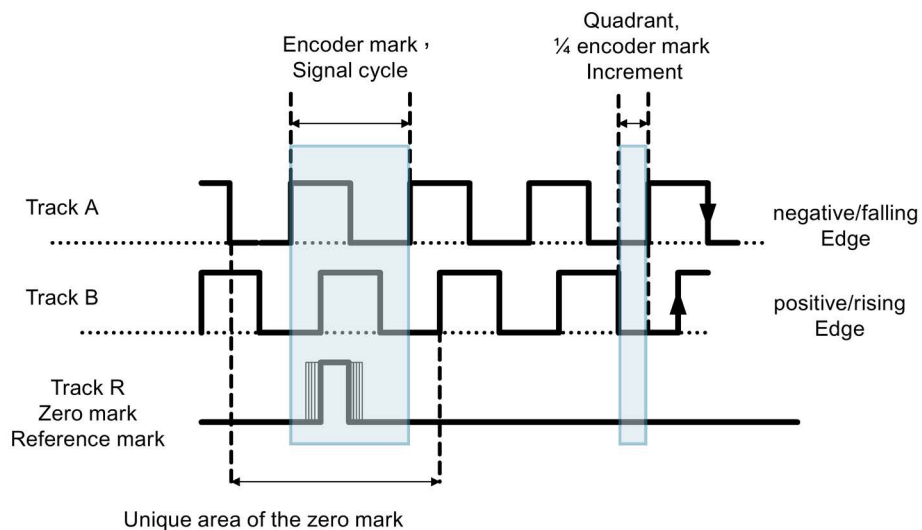

Figure 7-9 Terminology

Commissioning

The tolerant encoder monitoring is commissioned using parameters p0437 and r0459.
r0458.12 = 1 indicates whether your hardware supports the expanded encoder properties.

Note

- You can only parameterize the tolerant encoder monitoring functions when commissioning the encoder. The encoder monitoring parameters cannot be changed while the drive is running!
 - The functions can only be parameterized using the expert list of STARTER.
 - The functions described in the following apply to SMC30 modules and to Control Units with internal encoder evaluation.
-

7.20.1 Encoder track monitoring

For squarewave encoders with push-pull signals, this function monitors encoder tracks A/B ↔ -A/B, as well as R ↔ -R. The encoder track monitoring monitors the most important properties of the signals (amplitude, offset, phase position).

Commissioning

The following parameters must be set as requirement for track monitoring:

- p0404.3 = 1 switches to the square-wave encoder
- p0405.0 = 1 sets the signal to bipolar

Set p0405.2 = 1 to activate track monitoring.

If you selected your encoder from the list of parameter p0400, then the values above are pre-selected and cannot be changed (also refer to the information on p0400 in the SINAMICS S120/S150 List Manual).

Deactivating track monitoring

If encoder track monitoring is activated, you can deactivate the function by setting p0437.26 = 1.

Evaluating messages

All of the track monitoring functions can be individually evaluated. You can use both HTL as well as TTL encoders.

If a fault is detected, then fault F3x117¹⁾ is output. The faulty tracks are included in the fault value bit-coded.

Note

For modules CU310-2, CUA32, D410-2 and SMC30 (only article numbers 6SL3055-0AA00-5CA0 and 6SL3055-0AA00-5CA1), there is only a common signal. If you connect a square-wave encoder without R track to one of these modules, then if track monitoring is activated, fault F3x117¹⁾ is output.

To avoid this fault, at the encoder connection, you must connect the "ground encoder supply" (pin 7) with the "reference signal R" (pin 10), as well as the "encoder supply" (pin 4) with the "inverse reference signal R" (pin 11).

¹⁾ x = encoder number (x = 1, 2 or 3)

7.20.2 Zero mark tolerance

This function allows individual faults to be tolerated regarding the number of encoder pulses between two zero marks.

Commissioning

1. Set parameter p0430.21 = 1 to activate the "zero mark tolerance" function.

Sequence

The function runs as follows:

1. The "zero mark tolerance" function starts to become effective after the 2nd zero mark has been detected.
2. After this, if the number of track pulses between two zero marks does not match the configured number of pulses **once**, then alarm A3x400¹⁾ (alarm threshold, zero mark distance error) or A3x401¹⁾ (alarm threshold, zero mark failed) is output.
3. The alarm is cleared when the next zero mark is received at the correct position.
4. However, if a new zero mark position error is identified, fault F3x100¹⁾ (zero mark distance error) or Fx3101¹⁾ (zero mark failed) is output.

¹⁾ x = encoder number (x = 1, 2 or 3)

7.20.3 Freezing the speed raw value

If, for high speed changes, the dn/dt monitoring function responds, then the "freeze speed raw value" function gives you the opportunity of briefly specifying the actual speed value therefore equalizing the speed change.

Commissioning

1. Set parameter p0437.6 = 1 to activate the "freeze speed raw value" function.

Sequence

1. If the dn/dt monitor responds, the alarm A3x418 "Encoder x: Speed difference per sampling rate exceeded"¹⁾ is output.
2. A frozen actual speed value limited to just two current controller cycles is supplied.
3. The rotor position continues to integrate
4. The actual value is released again after two current controller cycles

¹⁾ x = encoder number (x = 1, 2 or 3)

7.20.4 Adjustable hardware filter

The adjustable hardware filter function allows an encoder signal to be filtered, therefore suppressing short interference pulses.

Commissioning

1. Set parameter p0438 ≠ 0 to activate the "adjustable hardware filter" function.

Parameterization

1. In parameter p0438 (square-wave encoder filter time) enter the filter time in the range from 0 to 100 μs. The hardware filter only supports values 0 (no filtering), 0.04 μs, 0.64 μs, 2.56 μs, 10.24 μs and 20.48 μs

If a value is set that does not match one of the discrete values specified above, the firmware automatically sets the next closest discrete value. The drive does not output an alarm or fault message.

2. You can see the active, effective filter time in parameter r0452.

Note

The zero mark alarms F3x100, F3x101 and F3x131¹⁾, that are already output for a zero mark with a width of ¼ encoder pulse at half n_max speed, are suppressed when the hardware filter is activated.

Effect

You can calculate the influence of the filter time on the maximum possible speed as follows:

$$n_{\max} [\text{rpm}] = 60 / (p0408 \cdot 2 \cdot r0452)$$

Here, p0408 is the pulse number of the rotary encoder.

Example

Specifications:

- p0408 = 2048
- r0452 = 10.24 [μs]

n_max is then calculated as follows:

- $n_{\max} = 60 / (2048 \cdot 2 \cdot 10.24 \cdot 10^{-6}) = 1430 [\text{rpm}]$

As a consequence, with this filter time you can operate the motor up to a maximum of 1430 rpm.

¹⁾ x = encoder number (x = 1, 2 or 3)

7.20.5 Edge evaluation of the zero mark

This functionality is suitable for encoders, where the zero mark ≥ 1 pulse wide. In this particular case, errors would otherwise occur as a result of the edge detection of the zero mark.

For a positive direction of rotation, the positive edge of the zero mark is evaluated and for a negative direction of rotation, the negative edge. As a consequence, for encoders where the zero mark is wider than one pulse, it is possible to parameterize them with equidistant zero marks (p0404.12 = 1), i.e. the zero mark checks (F3x100, F3x101¹⁾) are activated.

Commissioning

1. Set parameter p0437.1 = 1 to activate the "edge evaluation of the zero mark" function.
The factory setting p0437.1 = 0 keeps the operation at the known zero mark detection.

Parameterization

- Under unfavorable conditions, if the drive oscillates around the zero mark for one revolution, a zero mark error can occur with the rough order of magnitude of the zero mark width.
- This behavior can be avoided using the appropriate value of parameter "p4686 zero mark minimum length". You can assign $\frac{3}{4}$ of the zero mark width to parameter p4686 in order to achieve the most rugged behavior possible.
- In order that the drive, for small inaccuracies, does not output fault F3x100 (N, A) "Encoder x: Zero mark distance error"¹⁾ a small, adjustable deviation of the zero mark distances is permitted:
"p4680 zero mark monitoring tolerance permissible"
This parameter makes the system less sensitive to issuing F3x100¹⁾, if p0430.22 = 0 (no pole position adaptation) and p0437.2 = 0 (no pulse number correction for faults) are set.

¹⁾ x = encoder number (x = 1, 2 or 3)

7.20.6 Pole position adaptation

For example, for a dirty encoder disk, the drive adds the missing pulses to the pole position using the zero mark that is cyclically received in order to correct the pole position error. If, for example EMC interference causes too many pulses to be added, then these will be subtracted again every time the zero mark is crossed.

Commissioning

1. Set parameter p0430.22 = 1 to activate the "pole position adaptation" function.

Principle of operation

When the pole position adaptation is activated, the incorrect pulses on the A/B track are corrected in the pole position for commutation. The tolerance bandwidth for the zero mark is $\pm 30^\circ$ electrical. The rate of correction is $\frac{1}{4}$ of an encoder pulse between two zero marks; this means that sporadically missing or superfluous pulses are corrected.

Note

When the "Commutation with zero mark" function (p0404.15 = 1) is activated, then the system waits until fine synchronization has been completed before making a correction (r1992.8 = 1).

7.20.7 Pulse number correction for faults

Interference currents or other EMC faults can falsify encoder evaluation. However, it is possible to correct the measured signals using the zero marks.

Commissioning

1. Set p0437.2 = 1 to activate "Pulse number correction for faults".
2. Define the permissible tolerance (encoder pulses) for the zero mark distance (p4680).
3. Define the limits of the tolerance window, up to which the drive corrects the pulse number (p4681, p4682).
4. Using p4686, define the minimum zero mark length.

Sequence

1. This function completely corrects encoder pulse errors up to the tolerance window (p4681, p4682) between two zero marks. The rate of correction is $\frac{1}{4}$ encoder pulses per current controller cycle. As a consequence, it is possible to continually compensate for missing encoder pulses (for example, if the encoder disk is dirty). Using the two parameters, set the tolerance for the deviating pulse number.

If the deviation exceeds the tolerance window size, fault F3x131¹⁾ is output.

Note

When the "Commutation with zero mark" function (p0404.15 = 1) is activated, then the system waits until fine synchronization has been completed before making a correction (r1992.8 = 1).

The pole position for the commutation is also corrected. To do this, you do not have to activate pole position adaptation (p0430.22 = 1).

This function does not make any corrections in the speed sensing.

2. Using p4686, set the minimum zero mark length. With a factory setting of 1, it is prevented that EMC faults result in a zero mark error.
Shorter zero marks are only suppressed when "Zero mark edge detection" is parameterized (p0437.1 = 1).
3. Zero mark deviations of less than the minimum zero mark length (p4686) are not corrected.
4. A permanently failed zero mark is indicated using the fault F3x101 "Encoder x: Zero mark failed"¹⁾ or the alarm A3x401¹⁾ "Alarm threshold zero mark failed".

¹⁾ x = encoder number (x = 1, 2 or 3)

7.20.8 "Tolerance band pulse number" monitoring

This function monitors the number of encoder pulses between two zero marks. An alarm is output if the number lies outside a tolerance band that can be selected.

Commissioning

1. Set parameter p0437.2 = 1 to activate the monitoring.
2. Using parameters p4683 and p4684, set the upper and the lower limits of the tolerance band. Within this tolerance band, the detected number of pulses is considered to be correct.

Sequence

1. After each zero mark, it is again checked as to whether up to the next zero mark the number of pulses lies within the tolerance band. If this is not the case and "pulse number correction for faults" (p0437.2 = 1) is parameterized, then alarm A3x422¹⁾ is output for 5 seconds.
2. If one of the limits has a value of 0, then alarm A3x422¹⁾ is deactivated.
3. Display of uncorrected encoder pulses
For p0437.7 = 1, the number of corrected pulse errors is displayed in r4688 with the correct sign. Set p0437.7 = 0 in order to indicate the corrected pulse errors per zero mark distance in r4688.

For a drift after one revolution, if the tolerance band limit is not reached, an alarm is not output. A new measurement is performed if the zero mark is exceeded.

4. Number of pulses outside the tolerance band

If the tolerance band is violated, then in addition to alarm A3x422¹⁾ r4689.1 = 1 is set. This value remains for a minimum of 100 ms, so that a controller can detect several violations in quick succession one after the other even for high-speed drives.

You can send the message bits of parameter r4689 to a higher-level controller via PROFIBUS / PROFINET as process data.

5. You can send the accumulated correction value to a higher-level controller via PROFIBUS (e.g. p2051[x] = r4688). The controller can then set the contents of the counter to a specific value.

Note

The "tolerance band pulse number monitoring" also functions for external encoders which operate in a drive line-up as leading value encoder (monitoring the position value XIST1 from a direct measuring system).

¹⁾ x = encoder number (x = 1, 2 or 3)

7.20.9 Signal edge evaluation (1x, 4x)

The "signal edge evaluation" function allows square-wave encoders with higher production tolerances or older encoders to be used. Using this function, a "steadier" actual speed value is calculated for encoders with an uneven pulse duty factor of the encoder signals. As a consequence, you can keep the old motors together with the encoders - for example when modernizing plants.

Commissioning

1. Sets parameters p0437 bit 4 and bit 5 as follows to activate "signal edge evaluation":

p0437.4	p0437.5	Evaluation
0	0	4 x (factory setting)
0	1	Reserved
1	0	1 x
1	1	Reserved

Sequence

1. For the 4x evaluation, both the rising and falling edges of a contiguous pulse pair on the A and B tracks are evaluated.
2. For the 1x evaluation, only the first or the last edge of a contiguous pulse pair on the A and B tracks are evaluated.
3. A 4x evaluation of the pulse encoder signals allows a minimum speed to be detected which is a factor of 4 lower than for the 1x evaluation. For incremental encoders with uneven pulse duty factor of the encoder signals or where the encoder signals are not precisely offset by 90°, a 4x evaluation can result in an actual speed value that is somewhat less steady.
4. The following formula defines the lowest speed where a distinction can be made to 0:

$$n_{\min} = 60 / (x \cdot p0408) \text{ [rpm]}$$

with x = 1 or 4 (x times evaluation)

Note

You can only use the reduction to 1x evaluation in conjunction with the edge zero mark or without zero mark. Detection with an accuracy of one pulse is no longer possible for zero marks with "unambiguous range" or distance-coded zero marks.

7.20.10 Setting the measuring time to evaluate speed "0"

This function is only necessary for slow-speed drives (up to 40 rpm rated speed) in order to be able to output actual speeds correctly close to 0. For a stationary drive, this prevents that the I component of the speed controller slowly increases and the drive unnecessarily establishes a torque.

Commissioning

1. Enter the required measuring time in parameter p0453: A speed actual value of 0 is output, if, within this time, no pulses are detected from the A/B track.

7.20.11 Sliding averaging of the speed actual value

For slow-speed drives (< 40 rpm), when using standard encoders with a pulse number of 1024, a problem is encountered due to the fact that the same number of encoder pulses is not available for every current controller cycle (for p0430.20 = 1: Speed calculation without extrapolation, "Incremental difference"). The different number of encoder pulses means that the speed actual value display jumps, although the encoder itself is rotating at a constant speed.

Commissioning

1. For sliding averaging, set parameter p0430.20 = 0 (edge time measurement).
2. In parameter p4685, enter the number of current controller cycles over which the average value should be formed to calculate the speed.

The averaging means that individual incorrect pulses, depending on the number of specified cycles, are smoothed.

7.20.12 Troubleshooting

Table 7- 12 Fault profiles and their possible causes

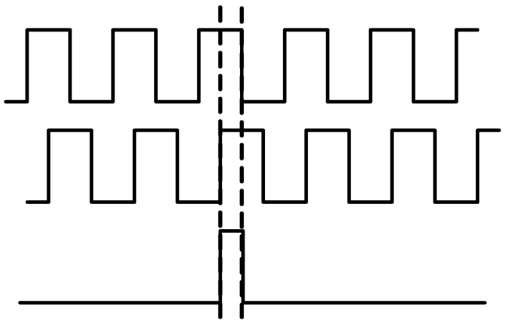
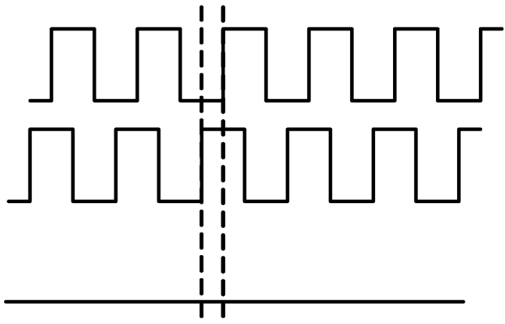
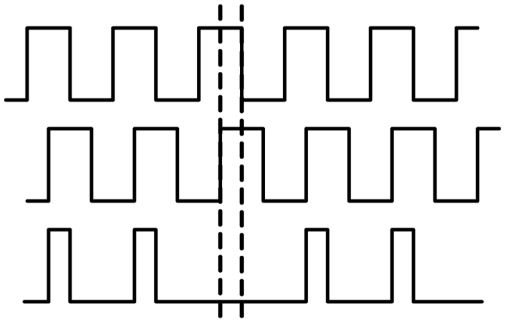
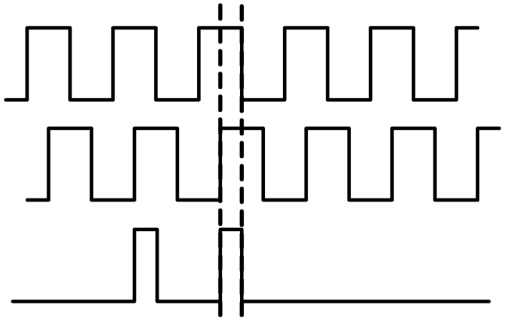
Fault profile	Fault description	Remedy
	No fault	-
	F3x101 (zero mark failed)	Check that the connection assignment is correct (A interchanged with -A or B interchanged with -B)
	F3x100 (Zero mark distance error)	Check whether the connection assignment is correct (R interchanged with -R)
	Interjected zero mark	Use zero mark tolerance

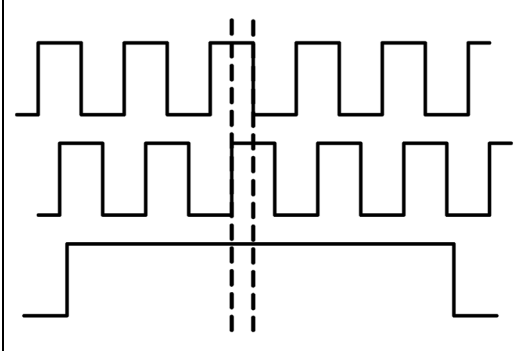
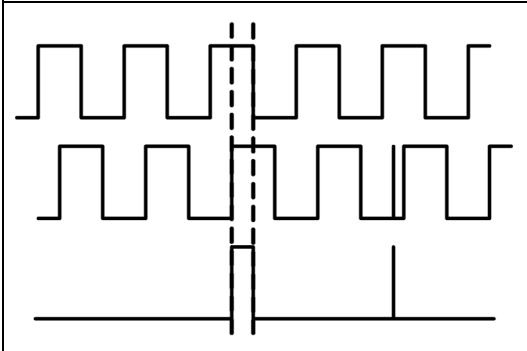
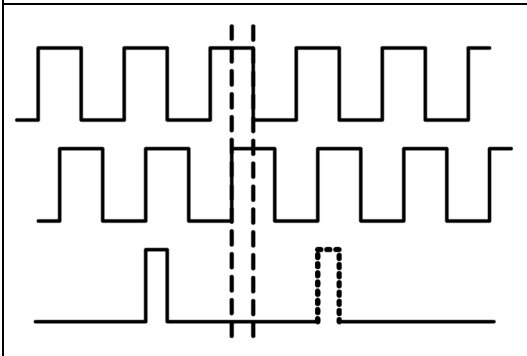
Fault profile	Fault description	Remedy
	<p>Zero mark too wide</p>	<p>Use edge evaluation of the zero mark</p>
	<p>EMC faults</p>	<p>Use an adjustable hardware filter</p>
	<p>Zero mark too early/late (interference pulse or pulse loss on the A/B track)</p>	<p>For faults, use pole position adaptation or pulse number correction</p>

7.20.13 Tolerance window and correction

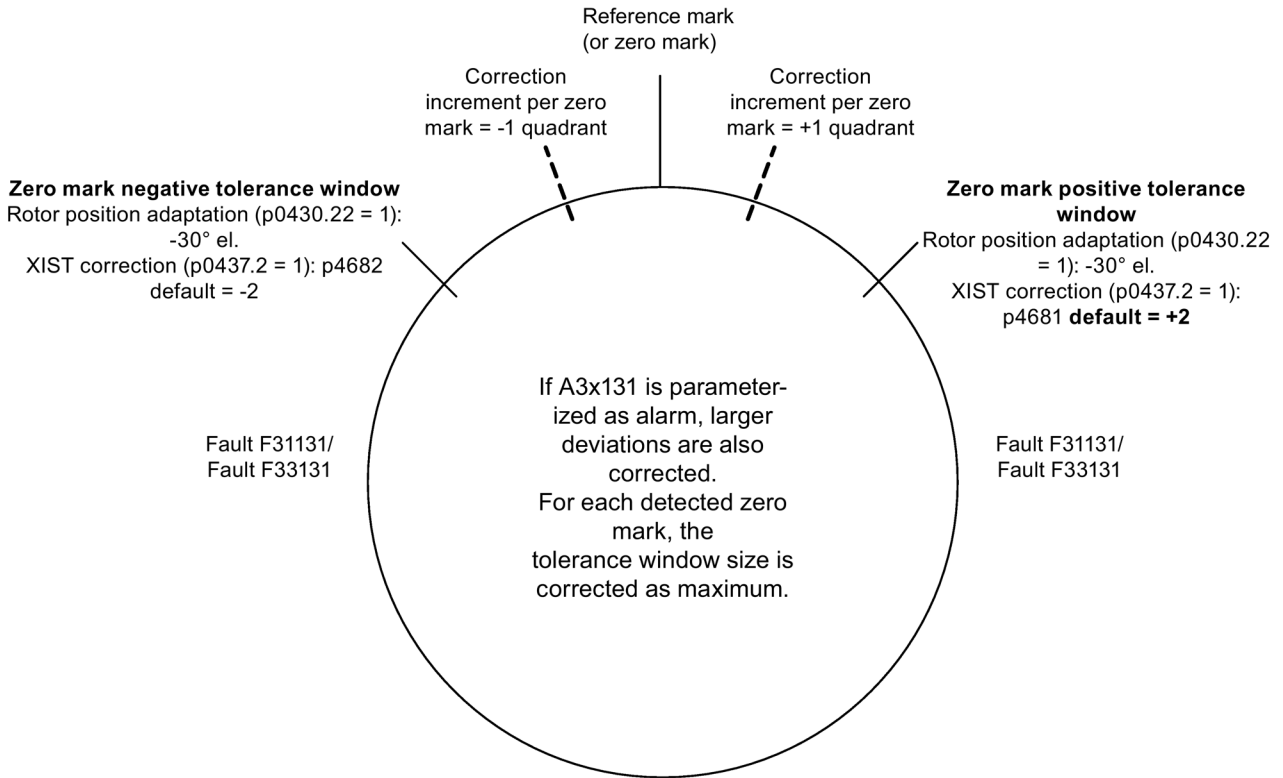

Figure 7-10 Tolerance window and correction

7.20.14 Dependencies

Parameter		Functionality										
		These functions can be freely combined with one another								These functions build on one another from left to right, and can be combined with the adjacent ones		
	Indices	1	2	3	4	5	6	7	8	9	10	11
p0405.2	Track monitoring	x										
p0430.20	Speed calculation mode							x				
p0430.21	Zero mark tolerance		x									
p0430.22	Rotor position adaptation									x		
p0437.1	Zero mark edge detection							x				
p0437.2	Actual position value correction XIST1										x	x
p0437.4	Edge evaluation								x			
p0437.5	Edge evaluation								x			
p0437.6	Freezing the actual speed for dn/dt errors			x								
p0437.7	Uncorrected encoder pulses accumulate										x	x
p0437.26	Deselection, track monitoring	x										
p0438	Square-wave encoder filter time				x							
r0452	Square-wave encoder filter time display				x							
p0453	Pulse evaluation zero speed measuring time					x						
p4680	Zero mark monitoring tolerance permissible							x			x	
p4681	Zero mark monitoring tolerance window limit 1 positive										x	
p4682	Zero mark monitoring tolerance window limit 1 negative										x	
p4683	Zero mark monitoring tolerance window alarm threshold positive											x
p4684	Zero mark monitoring tolerance window alarm threshold negative											x
p4685	Speed actual value averaging						x					
p4686	Zero mark, minimum length							x			x	
p4688	Zero mark monitoring, number of differential pulses										x	x
p4689	Square-wave encoder diagnostics										x	x
Messages												
F3x117	Inversion signal A and B error	x										

Parameter		Functionality										
		These functions can be freely combined with one another								These functions build on one another from left to right, and can be combined with the adjacent ones		
	Indices	1	2	3	4	5	6	7	8	9	10	11
F3x118	Speed difference outside tolerance			x								
F3x131	Deviation position incremental absolute too high										x	
A3x400	Alarm threshold zero mark distance error		x									
A3x401	Alarm threshold zero mark clearance failed		x									
A3x418	Speed difference per sampling rate exceeded			x								
A3x422	Number of pulses square-wave encoder outside tolerance											x

Table legend:

1. Encoder track monitoring
2. Zero mark tolerance
3. Freezing the speed setpoint
4. Adjustable hardware filter
5. The measuring time can be set to evaluate zero speed
6. Sliding averaging of the speed actual value
7. Edge evaluation of the zero mark
8. Signal edge evaluation (1x, 4x)
9. Pole position adaptation
10. Pulse number correction in the event of faults (pole position for commutation is also corrected)
11. "Tolerance band pulse number" monitoring

7.20.15 Overview of important parameters

Overview of important parameters (see SINAMICS S120/S150 List Manual)

- p0404[0...n] Encoder configuration active
- p0405[0...n] Square-wave encoder track A/B / square-wave encoder A/B
- p0408[0...n] Rotary encoder pulse No.
- p0430[0...n] Sensor Module configuration
- p0437[0...n] Sensor Module extended configuration
- p0438[0...n] Square-wave encoder filter time
- r0452[0...2] Square-wave encoder filter time display
- r0458[0...2] Sensor Module properties
- r0459[0...2] Sensor Module extended properties
- p4680[0...n] Zero mark monitoring tolerance permissible
- p4681[0...n] Zero mark monitoring tolerance window limit 1 positive
- p4682[0...n] Zero mark monitoring tolerance window limit 1 negative
- p4683[0...n] Zero mark monitoring tolerance window alarm threshold positive
- p4684[0...n] Zero mark monitoring tolerance window alarm threshold negative
- p4686[0...n] Zero mark, minimum length
- r4688[0...2] CO: Zero mark monitoring, number of differential pulses
- r4689[0...2] CO: Square-wave encoder diagnostics

7.21 Parking axis and parking encoder

The "parking" function is used in two ways:

- "Parking axis"
 - Monitoring of all encoders and Motor Modules assigned to the "Motor control" application of a drive are suppressed.
 - All encoders assigned to the "Motor control" application of a drive are prepared for the "removed" state.
 - The Motor Module assigned to the "Motor control" application of a drive is prepared for the "removed Motor Module" state.
- "Parking encoder"
 - Monitoring of a certain encoder is suppressed.
 - The encoder is prepared for the "removed" state.

Parking an axis

When an axis is parked, the power unit and all the encoders assigned to the "motor control" are switched to inactive ($r0146[n] = 0$).

- Control is carried out via the control/status words of the cyclic telegram (STW2.7 and ZSW2.7) or using parameters p0897 and r0896.0.
- The drive must be brought to a standstill by the higher-level controller (disable pulses, e.g. via STW1.0/OFF1).
- DRIVE-CLiQ communication to downstream components via the deactivated power unit ($r0126 = 0$) remains active.
- A measuring system that is not assigned to the "motor control" (e.g. direct measuring system) remains active ($r0146[n] = 1$).
- The drive object remains active ($r0106 = 1$).

Note

Once the "Parking axis" / "Parking encoder" status has been canceled, you may have to carry out the following actions:

- If the motor encoder has been replaced: determine the commutation angle offset (p1990).
 - A new encoder must be referenced again (e.g. to determine the machine zero point).
-

Parking an encoder

When an encoder is parked, the encoder being addressed is switched to inactive (r0146 = 0).

- Control is carried out via the encoder control/status words of the cyclic telegram (Gn_STW.14 and Gn_ZSW.14).
- With a parked motor measuring system, the associated drive must be brought to a standstill by the higher-level control system (disable pulses e.g. via STW1.0/OFF1).
- The monitoring functions for the power unit remain active (r0126 = 1).

Note

Removing/replacing parked components

Once parked components have been disconnected/connected, they can only be unparked once they have been successfully integrated in the actual topology (see r7853).

Example: Parking axis

In the following example, an axis is parked. To ensure that the axis parking is effective, the drive must be brought to a standstill (e.g. via STW1.0 (OFF1)). All components assigned to the motor control (e.g. power unit and motor encoder) are shut down.

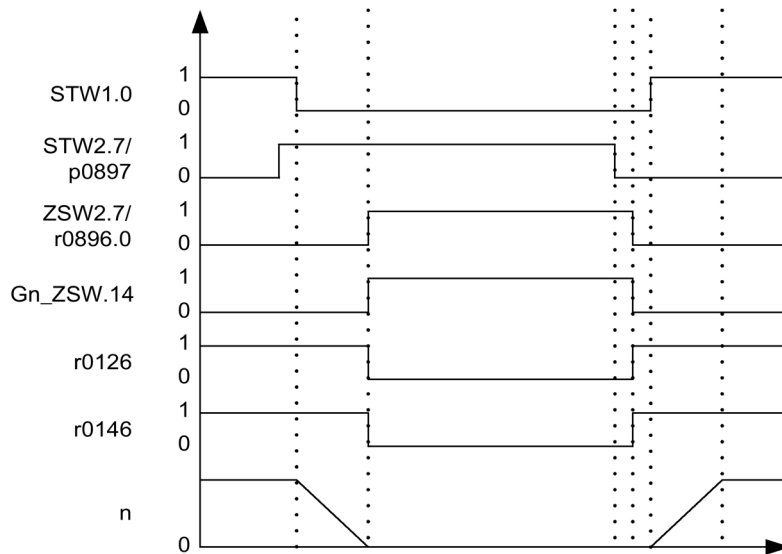

Figure 7-11 Flow diagram: parking axis

Example: Parking encoder

In the following example, a motor encoder is parked. To activate motor encoder parking, the drive must be stopped (e.g. via STW1.0 (OFF1)).

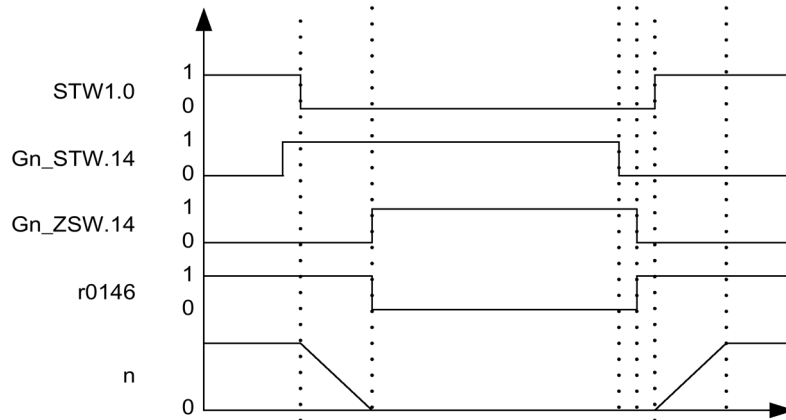

Figure 7-12 Function chart: parking encoder

Overview of important parameters (see SINAMICS S120/S150 List Manual)

- p0105 Activate/deactivate drive object
- r0106 Drive object active/inactive
- p0125[0...n] Activate/deactivate power unit component
- r0126[0...n] Power unit components active/inactive
- p0145[0...n] Enable/disable sensor interface
- r0146[0...n] Sensor interface active/inactive
- p0895[0...n] BI: Activate/deactivate power unit component
- r0896.0 BO: Parking axis status word
- p0897 BI: Parking axis selection

7.22 Position tracking

7.22.1 General information

Terms

- Encoder range
The position area that can itself represent the absolute encoder.
- Singleturn encoder
A rotating absolute encoder, which provides an absolute image of the position within one encoder revolution.
- Multiturn encoder
An absolute encoder that provides an absolute image of the position over several encoder revolutions (e.g. 4096 revolutions).

Description

Position tracking enables the load position to be reproduced when using gearboxes. It can also be used to extend the position area.

With position tracking, an additional measuring gear can be monitored and also a load gear, if the "position control" function module (p0108.3 = 1) is active. Position tracking of the load gearbox is described in Section "Actual position value processing".

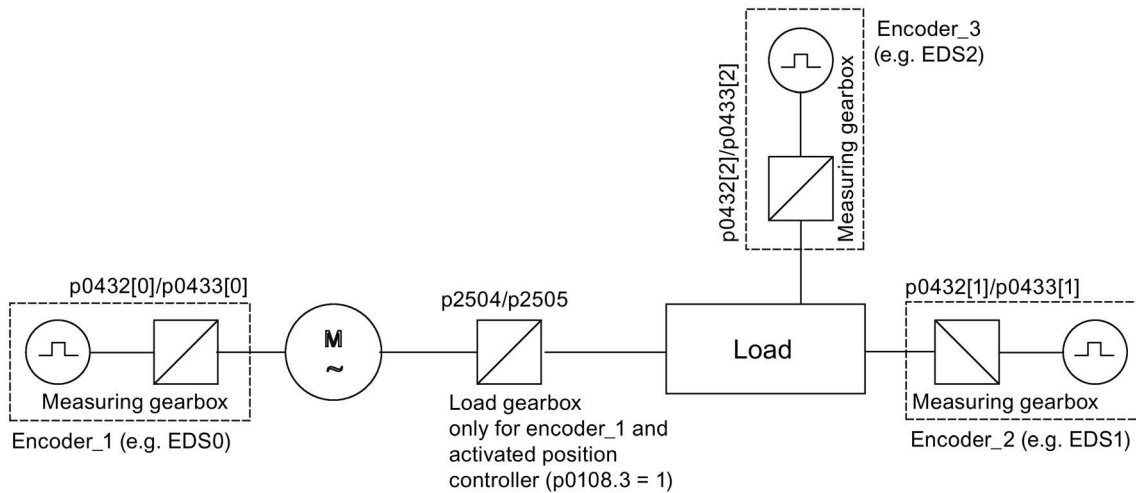

Figure 7-13 Overview of gears and encoders

The encoder actual position value in r0483 (must be requested via GnSTW.13) is limited to 2^{32} places. When position tracking (p0411.0 = 0) is switched off, the encoder actual position value r0483 comprises the following position information:

- Encoder pulses per revolution (p0408)
- Fine resolution per revolution (p0419)
- Number of resolvable revolutions of the rotary absolute encoder (p0421), this value is fixed at "1" for singleturn encoders.

When position tracking (p0411.0 = 1) is activated, the encoder actual position value r0483 is composed as follows:

- Encoder pulses per revolution (p0408)
- Fine resolution per revolution (p0419)
- Virtual number of resolvable motor revolutions of a rotary absolute encoder (p0412)

If the measuring gear is absent (n=1), the actual number of the stored revolutions of a rotary absolute encoder p0421 is used. The position area can be extended by increasing this value.

If the measuring gear is available, this value equals the number of resolvable motor revolutions, which is stored in r0483.

- Gearbox ratio (p0433/p0432)

7.22.2 Measuring gearbox

If a mechanical gear (measuring gear) is located between an endlessly rotating motor/load and the encoder and position control is to be carried out using this absolute encoder, an offset occurs (depending on the gear ratio) between the zero position of the encoder and the motor/load whenever encoder overflow occurs.

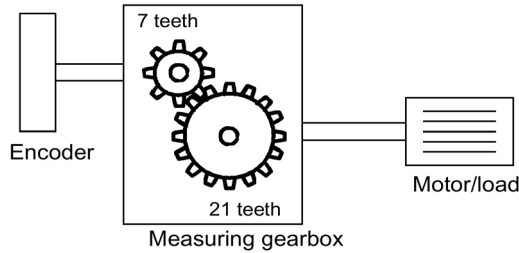

Figure 7-14 Measuring gearbox

In order to determine the position at the motor/load, in addition to the actual position value of the absolute encoder, it is also necessary to have the number of absolute encoder overflows.

If the power supply of the control module must be powered-down, then the number of overflows must be saved in a non-volatile memory so that after powering-up the position of the load can be uniquely and clearly determined.

Example: Gear ratio 1:3 (motor revolutions p0433 to encoder revolutions p0432), absolute encoder can count eight encoder revolutions (p0421 = 8).

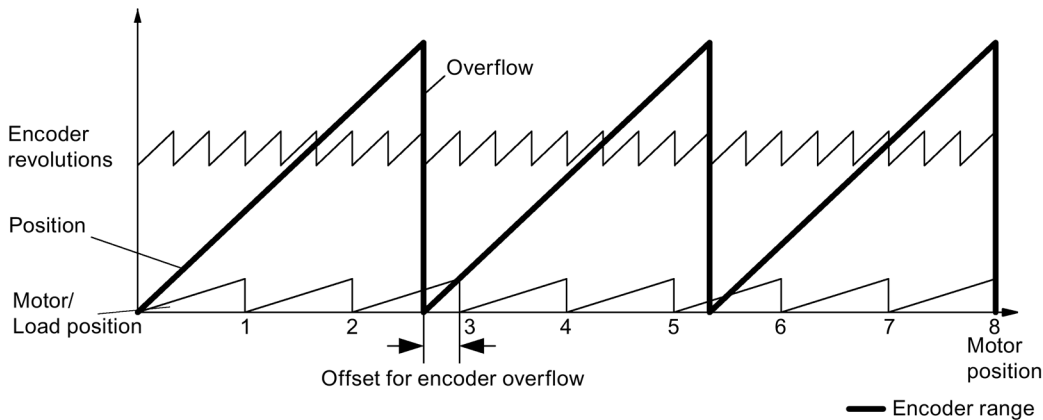

Figure 7-15 Drive with odd-numbered gearboxes without position tracking

In this case, for each encoder overflow, there is a load-side offset of 1/3 of a load revolution, after three encoder overflows, the motor and load zero position coincide again. The position of the load can no longer be clearly reproduced after one encoder overflow.

If position tracking is activated via $p0411.0 = 1$, the gear ratio ($p0433/p0432$) is calculated with the encoder actual position value ($r0483$).

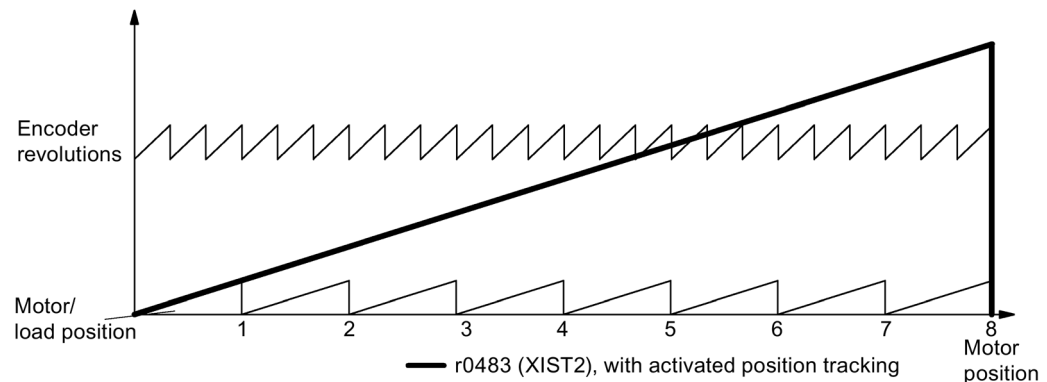

Figure 7-16 Odd-numbered gears with position tracking ($p0412 = 8$)

Features

- Configuration via $p0411$
- Virtual multiturn via $p0412$
- Tolerance window for monitoring the position at power ON $p0413$
- Input of the measuring gear via $p0432$ and $p0433$
- Display via $r0483$

Measuring gear configuration ($p0411$)

The following points can be set by configuring this parameter:

- $p0411.0$: Activation of position tracking
- $p0411.1$: Setting the axis type (linear axis or rotary axis)

Here, a rotary axis refers to a modulo axis (modulo offset can be activated through higher-level controller or EPOS). With a linear axis, position tracking is mainly used to extend the position area (see Section Virtual multiturn encoder ($p0412$)).

- $p0411.2$: Reset position

Overflows can be reset with this. This is required, for example, if the encoder is turned by more than $1/2$ the encoder range while switched off.

Virtual multiturn encoder (p0412)

With a rotary absolute encoder (p0404.1 = 1) with activated position tracking (p0411.0 = 1), p0412 can be used to enter a virtual multiturn resolution. This enables you to generate a virtual multiturn encoder value (r0483) from a singleturn encoder. It must be possible to display the virtual encoder range via r0483.

Note

If the gear factor is not equal to 1, then p0412 always refers to the motor side. The virtual resolution, which is required for the motor, is then used here.

For rotary axes with modulo offset, the virtual multiturn resolution (p0412) is preset as p0421 and can be changed.

For linear axes, the virtual multiturn resolution (p0412) is preset as p0421 and extended by 6 bits for multiturn information (max. overflows 31 positive/negative)

If, as a result of extension of the multiturn information, the displayable area of r0483 (2^{32} bit) is exceeded, the fine resolution (p0419) must be reduced accordingly.

Tolerance window (p0413)

After switching on, the difference between the stored position and the actual position is determined and, depending on the result, the following is initiated:

- Difference within the tolerance window
The position is reproduced based on the actual encoder value.
- Difference outside the tolerance window
Message F07449 is output.
- The tolerance window is preset to quarter of the encoder range and can be changed.

Note

The position can only be reproduced if, in the powered-down state, the encoder was moved through less than half of the range that it can represent. For the standard EQN1325 encoder, this is 2048 revolutions or half a revolution for singleturn encoders.

Note

The ratio stamped on the gear rating plate is often just a rounded-off value (e.g. 1:7.34). If, for a rotary axis, it is not permissible to have any long-term drift, then the actual ratio of the gear teeth must be requested from the gear manufacturer.

Note regarding using synchronous motors with a measuring gear

Field-oriented control of synchronous motors requires a clear reference between the pole position and encoder position. This reference must also be carefully maintained when using measuring gears: This is the reason that the ratio between the pole pair number and the encoder revolutions must be an integer multiple ≥ 1 (e.g. pole pair number 17, measuring gear 4.25, ratio = 4).

Commissioning

The position tracking of the measuring gear can be activated in the drive wizard (STARTER) during the configuration of the drive. During the configuration there is an item for encoder parameterization. In the encoder dialog, click the "Details" button and activate the checkbox for position tracking in the displayed dialog.

The parameters p0412 (Measuring gear, rotary absolute encoder, revolutions, virtual) and p0413 (Measuring gear, position tracking tolerance window) can only be set via the expert list.

Requirement

- Absolute encoder

Function diagrams (see SINAMICS S120/S150 List Manual)

- 4704 Encoder evaluation - Position and temperature sensing, encoders 1 ... 3

Overview of important parameters (see SINAMICS S120/S150 List Manual)

- p0402[0...n] Gear unit type selection
- p0411[0...n] Measuring gear configuration
- p0412[0...n] Measuring gear, absolute encoder, rotary revolutions, virtual
- p0413[0...n] Measuring gear, position tracking tolerance window
- p0421[0...n] Absolute encoder rotary multiturn resolution
- p0432[0...n] Gear factor encoder revolutions
- p0433[0...n] Gear factor motor/load revolutions
- r0477 CO: Measuring gear, position difference
- r0485 CO: Measuring gear, raw encoder value, incremental
- r0486 CO: Measuring gear, raw encoder value, absolute

7.23 Creating an encoder as drive object

Encoders can be linked in as autonomous drive objects (Drive Object =DO) and evaluated. An ENCODER drive object can be addressed as encoder via PROFIBUS/PROFINET as an independent unit.

Using an ENCODER drive object allows an encoder of an upstream machine to be directly connected via a Sensor Module without having to take an indirect route via the 2nd encoder of a drive. The encoder is connected via an encoder interface of a Sensor Modules. If the Sensor Modules, to which the encoder is connected, has its own DRIVE-CLiQ interface (e.g. an SME20), then the encoder can be connected to any free DRIVE-CLiQ socket via the Sensor Module.

7.23.1 Preconditions for creating an ENCODER drive object using STARTER

Requirements

- As of STARTER V4.1.5
- Project with one CU320-2

The project can also be created OFFLINE. A description of this can be found in Section "Commissioning" in the SINAMICS S120 Commissioning Manual.

Connection conditions for ENCODER drive objects

- All encoders that can be assigned to a drive can be used.
- ENCODER drive objects may be connected to all DRIVE-CLiQ ports.
- Up to 4 DRIVE-CLiQ HUBs (DMC20 or DME20) can be used to establish a star-shaped wiring of the ENCODER drive objects. This means that a maximum of 19 possible ENCODER drive objects can be connected to one Control Unit.
(This means that the number of possible ENCODER drive objects is restricted so that a maximum of 24 drive objects can be connected to one Control Unit.)
- The DRIVE-CLiQ HUBs must be directly connected to the Control Unit.

7.23.2 Creating an ENCODER drive object

Creating/inserting an ENCODER drive object is described using a CU320-2 as an example. In this example, the project is created OFFLINE using the STARTER commissioning tool.

In the project navigator, you can find the selection of the ENCODER drive object between "Input/output components" and "Drives".

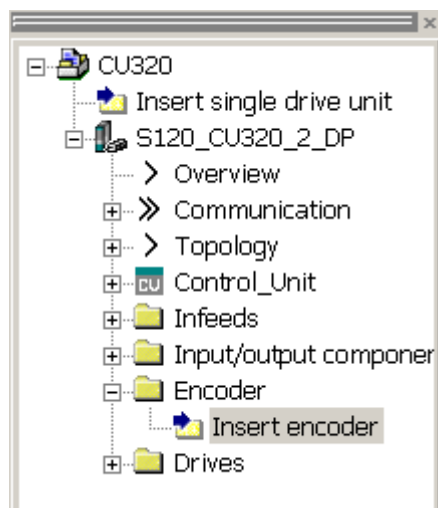

Figure 7-17 Project navigator, inserting an "Encoder" drive object

Procedure

1. Double-click "Insert encoder".
The "Insert Encoder" dialog box opens.
2. Enter a name for the encoder in the "Name:" input field.
3. Click the "Drive object no." button.
4. Enter a new drive object number in the "Drive object no." input field.
All assigned drive object numbers are shown in the "Assigned drive object no." list.
5. Click "OK".
The configuration window for encoders opens.
6. Select your encoder from the "List of standard encoders", or enter the basis data of the encoder under "Enter data".
7. Follow the configuration wizard to set-up the encoder.
8. Finally, click the "Finish" button.
The encoder is now inserted into your topology and is available.

7.24 Terminal Module 41

Terminal Module 41 is characterized by the following features:

- Pulse encoder emulation, TTL signals according to the RS422 standard (X520)
- 1 analog input
- 4 digital inputs
- 4 bidirectional digital inputs/outputs

Terminal Module 41 (TM41) emulates incremental encoder signals (TTL) - and outputs them via interface X520. The signals are based on speed setpoints transferred via process data words (SIMOTION mode) or created on the actual position value of a leading encoder (SINAMICS mode). The emulated incremental encoder signal can be used by external hardware or a higher-level controller.

The number of pulses output (virtual pulses) per revolution can be set over a wide range.

With the additional inputs and outputs, these can be used for example to transfer analog speed setpoints or control and status signals, for example OFF1/ON, "ready for operation" or "fault".

7.24.1 SIMOTION mode

The SIMOTION mode of the incremental encoder emulation is set using parameter p4400 = 0. The incremental encoder emulation is based on the speed setpoint.

A speed setpoint r2060 is received via PROFIdrive telegram 3, which is interconnected to p1155. The speed setpoint can be filtered using a (p1414.0) PT2 element that can be activated (p1417 and p1418). The speed setpoint can be delayed with the dead time p1412. The number of encoder pulses per revolution can be set using parameter p0408. The distance between the zero marks and the position when enabling the A/B tracks (r4402.1) is entered into parameter p4426 and enabled with p4401.0 = 1.

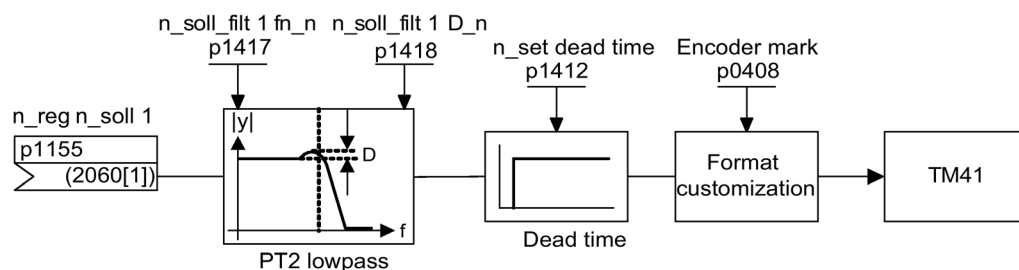

Figure 7-18 Function diagram encoder emulation

Special features

- PROFIdrive telegram 3
- Own control word (r0898)
- Own status word (r0899)
- Sequence control (refer to function diagram 9682)
- Settable zero mark position (p4426)
- Operating display (r0002)

7.24.2 SINAMICS mode

The SINAMICS mode of the incremental encoder emulation is set using parameter p4400 = 1. The incremental encoder emulation is based on the encoder actual position value of the leading encoder.

The actual position values of the leading encoder are interconnected to the Terminal Module 41 via a connector input (p4420). This is possible for every encoder, irrespective of the drive object to which it is assigned. This means that the actual position values at the TM41 are available as pulse encoder emulation - including the zero mark. The signals of the pulse encoder emulation appear just like the signals of a TTL encoder - and can be processed by an external controller or hardware.

Note

Connector input p4420 should be interconnected with signal source r0479 (diagnostics encoder actual position value Gn_XACT1). The value is updated with each DRIVE-CLiQ base cycle and displayed with the correct sign.

The TM41 supports a step-up/step-down ratio between the output signal of the leading encoder and the output signal of the TM41. The number of encoder pulses per revolution of the leading encoder is set using p4408. The pulse number of the TM41 encoder emulation is set using p0408. The parameters p4408 and p0408 may have any relationship with each other.

The zero mark signal for the TM41 is generated from the zero position of the leading encoder. Parameters p0493, p0494 and p0495 of the drive/encoder object apply to the generation of the zero position of the leading encoder.

Special features

- The runtime of the encoder actual position value up to the pulse encoder emulation can be compensated using the deadtime compensation with p4421.
- The pulse number ratio between the encoder to be emulated and the emulating TM41 can be set as required. For each encoder revolution, in the encoder emulation, more or fewer pulses are output than were read-in from the original encoder.
- If p4422 = 1, input signal p4420 is inverted.
- Only one Encoder Data Set (EDS) can be interconnected to precisely one TM41.
- When the same EDS is interconnected to an additional TM41, only the actual position value can be emulated – but not the zero mark position.
- Using p4401.1 = 1, the zero position is synchronized with the zero mark of the absolute encoder. If you have to remain compatible with older firmware versions, for example for use in an existing control system, set parameter p4401.1 = 0.
 - p4401.1 = 0: No synchronous zero marks
 - p4401.1 = 1: Zero mark synchronization enabled
 - As soon as the absolute encoder passes the zero position of the absolute position, then the zero pulse is output via X520.
- PROFIdrive telegram 3

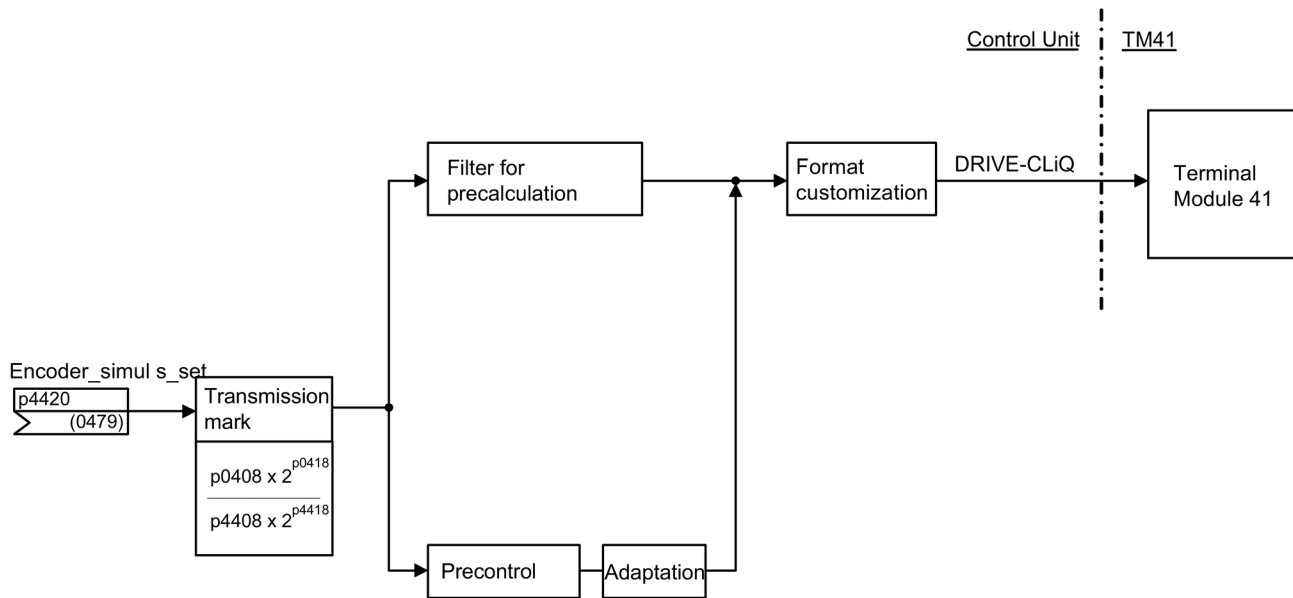

Figure 7-19 Incremental encoder emulation

7.24.3 Zero mark emulation (SINAMICS mode)

The referencing mode set for the leading encoder is used to determine the zero mark position for the zero mark emulation of the TM41.

Possible referencing modes are:

- Referencing to the zero position of the encoder
 - Encoder zero mark of an incremental encoder
 - Zero passage of the singleturn position of an absolute encoder
 - Pole pitch of the resolver
- Referencing to the zero position of the encoder with selection of the correct zero position using a BERO switching signal (CU parameter p0493)
- Referencing to an external zero mark connected via an input terminal (CU parameter p0495)

Note

Original encoder with several zero marks

If the original encoder (leading encoder) has several zero marks/positions, an additional condition (BERO signal) must be selected for the required zero mark.

Adjustable zero mark offset at the TM41 output

An offset of the pulse grid can be set for the the zero mark position of the encoder emulation using p4426.

Example of a pulse number step-up ratio

The leading encoder emits 12 pulses and a zero mark per revolution. However, the application requires 32 pulses per revolution. By setting p4408 and p4418, the required 32 pulses a revolution are available at X520 of the TM41.

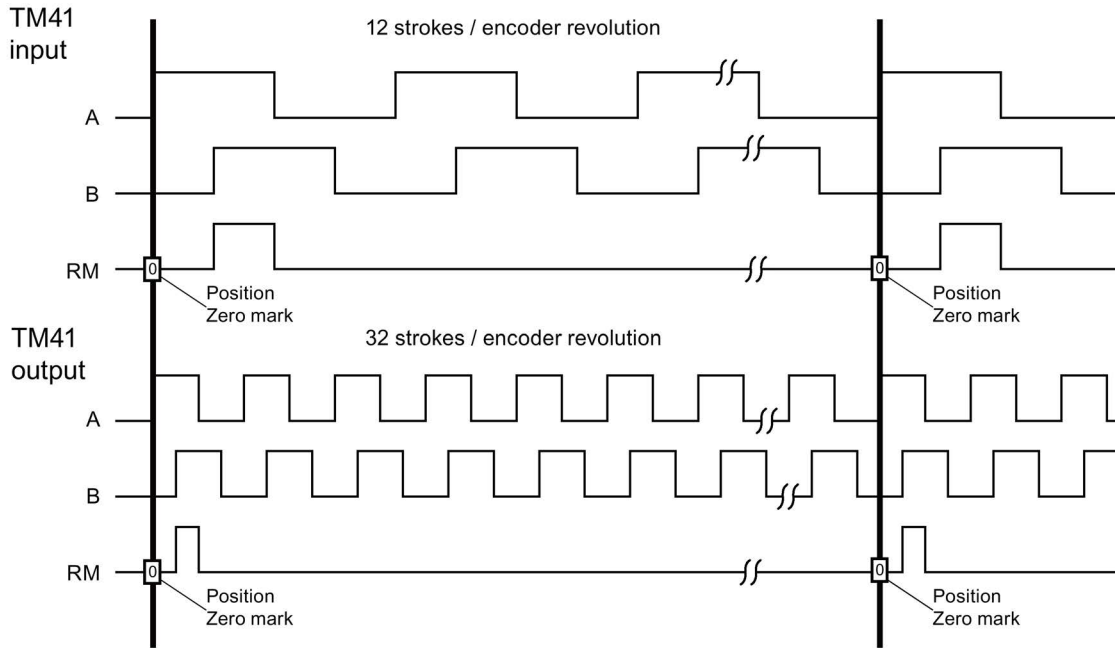

Figure 7-20 Step-up ratio of the encoder pulse number

Example of a pulse number step-up ratio with several zero positions

If the original encoder has several zero positions/marks per revolution (e.g. resolver with several pole pairs), the correct zero mark must be selected via an additional condition. Otherwise, there is no reproducible relationship between the position of the original encoder and the zero mark position of the encoder emulation.

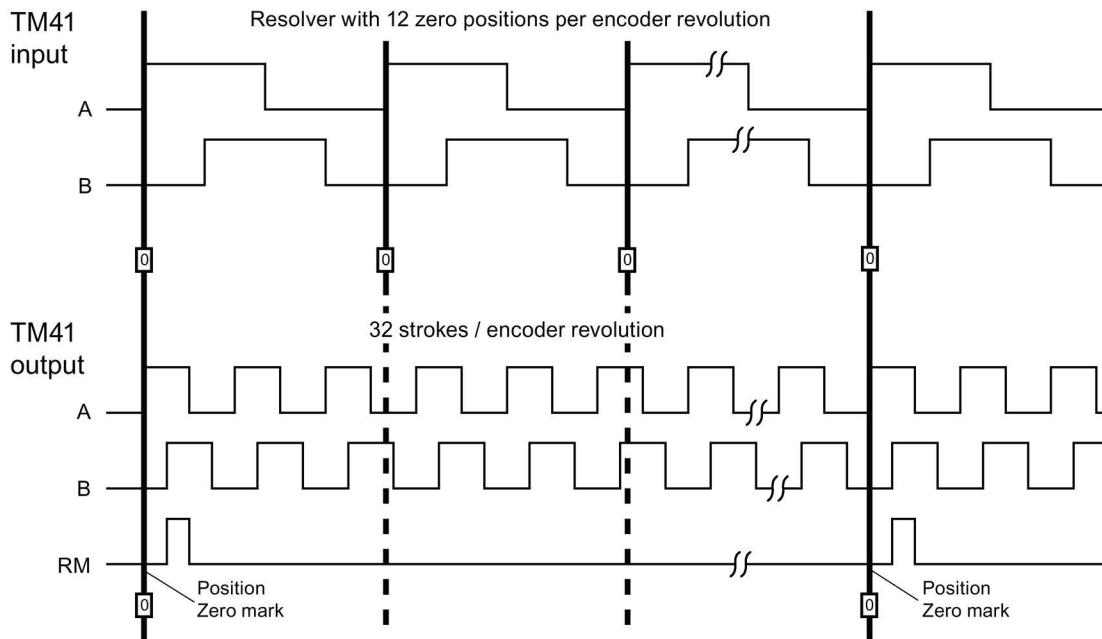

Figure 7-21 Step-up ratio with several zero positions per revolution

Parameterization

The pulse numbers of the leading encoder (the signal source) are set using p4408 and p4418. To synchronize the generated zero mark with the zero mark of the leading encoder, the pulse number per encoder revolution of the encoder at the TM41 input (p4408) must always precisely coincide with the pulse number per encoder revolution of the encoder interconnected at connector input p4420.

The pulse numbers emulated by the TM41 are set using p0408 and p0418. If p4408 = 0 is set then the values from p0408 and p0418 also apply for the output of the TM41.

Diagnostic options

Parameter r4419 shows the calculated position setpoint after the step-up/step-down. Using the trace function of the STARTER commissioning tool, you can check the step-up/step-down function based on r4419.

Enabling the zero mark output of the TM41

For p4401.1 = 1, the zero mark from the leading encoder is also output from the TM41. For p4401.1 = 0, TM41 outputs the zero pulse at the position at which the TM41 was located when switching on.

7.24.4 Synchronization of the zero marks (SINAMICS mode)

After the drive has been powered up, a static offset is obtained as a result of the random switch-on instant of the incremental encoder emulation.

This static offset can be corrected using this function. The positions of the zero marks output at the TM41 are synchronized with the zero marks of the leading encoder. The following conditions are defined for synchronization:

- The reference mark is located at the position at which both track signals A and B have the "high" status.
- The zero position is the positive edge of the A track belonging to the reference mark, which for a positive direction of rotation comes before the zero mark.

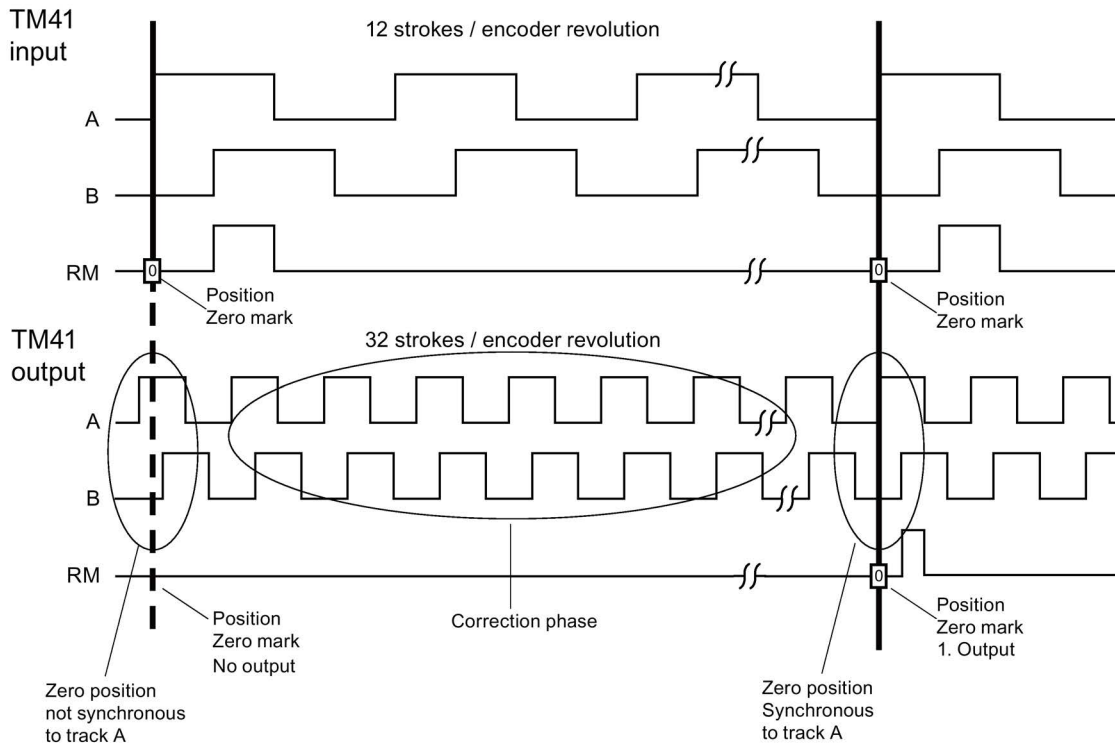

Figure 7-22 Example: Zero mark synchronization

Layout of the synchronization:

- After the SINAMICS system has been powered up, the TM41 drive object requests the zero position of the leading encoder via the encoder interface. The encoder emulation follows the movements of the leading encoder and outputs the track signals A/B. At this point in time, no zero mark is output. The edges of the A track are still not in synchronism with the leading encoder.
- The TM41 receives this position after passing the zero position of the leading encoder. The output of the track signals is now corrected in such a way that the positive edge of the A track is in synchronism with the zero position.
- After successful synchronization, the zero mark is output at the zero positions.

Detecting the zero mark position for new synchronization

If the number of encoder pulses has not been set equal to 2^n (for example $p0408 = 1000$), then after the higher-level controller has been reset, it is possible that the position of the next zero mark cannot be determined from the actual position value $xACT1$ signaled from the TM41. For this situation, the control can query the position of the next zero mark from parameter $r4427$ using an acyclic read request.

7.24.5 Limit frequencies for TM41

- Adjustable pulse number ($p0408$): 32 to 16384 pulses/revolution (factory setting = 2048)
- The maximum pulse frequencies (limit frequencies) specified in the tables below must not be exceeded.

Table 7- 13 Maximum output frequencies for TM41 = 750 kHz ($p4401.7 = 0$)

Higher setpoint resolution not activated ($p4401.5 = 0$)				
Sampling time $p4099[3]$		125 μ s	250 μ s	500 μ s
Resolution		31.25 Hz	15.625 Hz	7.8125 Hz
SINAMICS mode $p4400 = 1$	Output frequency f_{max} ($p0418 < 17$ bit)	1024 kHz	512 kHz	256 kHz
	Output frequency f_{max} ($p0418 = 17$ bit)	512 kHz	256 kHz	128 kHz
	Output frequency f_{max} ($p0418 = 18$ bit)	256 kHz	128 kHz	64 kHz
SIMOTION mode $p4400 = 0$	Output frequency f_{max}	1024 kHz	512 kHz	256 kHz

Table 7- 14 Maximum output frequencies for TM41 = 1024 kHz ($p4401.7 = 1$)

Higher setpoint resolution activated ($p4401.5 = 1$)				
Sampling time $p4099[3]$		125 μ s	250 μ s	500 μ s
Resolution		0.122 Hz	0.061 Hz	0.031 Hz
SINAMICS mode $p4400 = 1$	Output frequency f_{max} ($p0418 < 17$ bit)	1024 kHz	512 kHz	256 kHz
	Output frequency f_{max} ($p0418 = 17$ bit)	512 kHz	256 kHz	128 kHz
	Output frequency f_{max} ($p0418 = 18$ bit)	256 kHz	128 kHz	64 kHz
SIMOTION mode $p4400 = 0$	Output frequency f_{max}	1024 kHz	1024 kHz	1024 kHz

Following error monitoring

If the actual position can no longer follow the entered position setpoint characteristic, then fault F35220 is output. In the SINAMICS mode, the frequency setpoint is limited to the maximum output frequency. The maximum output frequency from the TM41 is transferred to the Control Unit.

7.24.6 Example in the SINAMICS mode

The signals of the leading encoder should be adapted using the TM41 and transferred to the SERVO drive object.

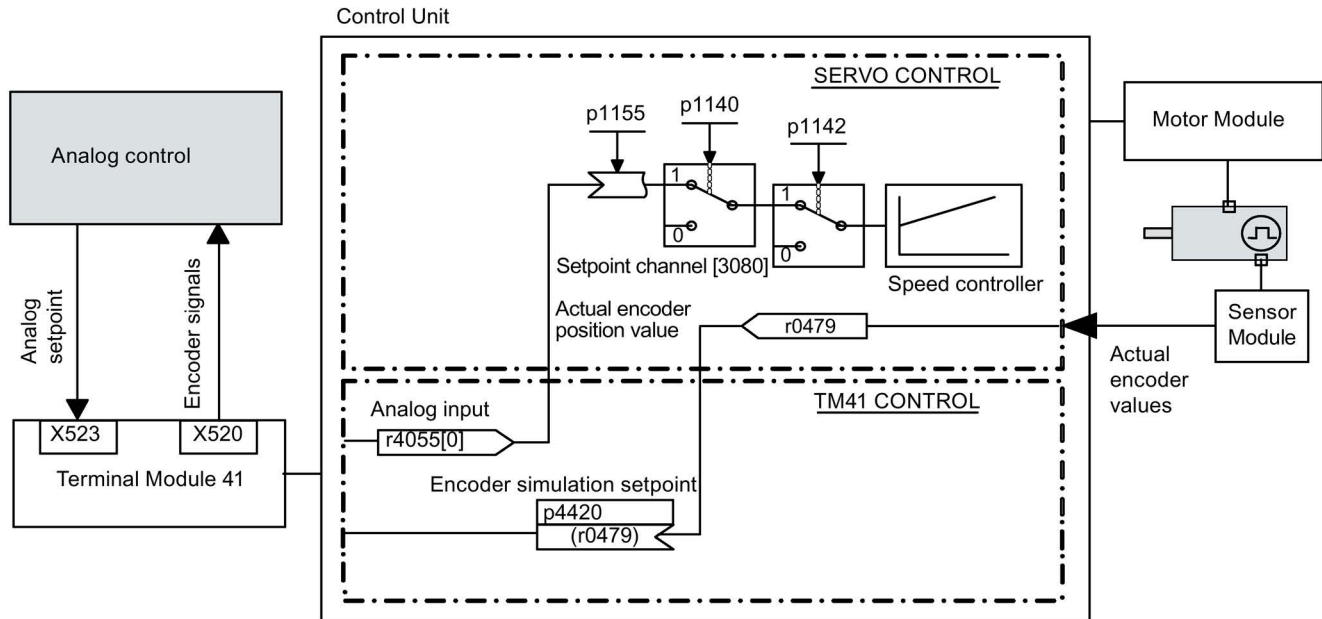

Figure 7-23 Example: TM41

Commissioning the example

Input of parameter values via STARTER screen form:

- p4400 = 1 (encoder emulation by means of encoder actual position value)
- p4420 = r0479[n] (SERVO or VECTOR), n = 0...2
- p4408 = sets the gear ratio pulse number (this must correspond to the pulse number of the leading encoder)
- p4418 = sets the fine resolution of the signal source (this must correspond to the fine resolution of the leading encoder)
- p0408 = sets the pulse number of the encoder emulation
- p0418 = sets the fine resolution of the encoder emulation

Note

To be able to signal encoder emulation faults of the TM41 to a higher-level controller, parameter r2139.0...8 CO/BO: Status word faults/alarms 1 must be interconnected via a BICO with a digital output (TM41 or CU) which can be read by the external control system.

7.24.7 Function diagrams and parameters

Function diagrams (see SINAMICS S120/S150 List Manual)

- 9659 Terminal Module 41 (TM41) - Overview
- 9660 Terminal Module 41 (TM41) - digital inputs, isolated (DI 0 ... DI 3)
- 9661 Terminal Module 41 (TM41) - Digital inputs/outputs, bidirectional (DI/DO 0 ... DI/DO 1)
- 9662 Terminal Module 41 (TM41) - Digital inputs/outputs, bidirectional (DI/DO 2 ... DI/DO 3)
- 9663 Terminal Module 41 (TM41) - Analog input 0 (AI 0)
- 9674 Terminal Module 41 (TM41) - Incremental encoder emulation (p4400 = 0)
- 9676 Terminal Module 41 (TM41) - Incremental encoder emulation (p4400 = 1)
- 9678 Terminal Module 41 (TM41) - Control word, sequence control (p4400 = 0)
- 9680 Terminal Module 41 (TM41) - Status word sequence control
- 9682 Terminal Module 41 (TM41) - Sequencer (p4400 = 0)

Overview of important parameters (see SINAMICS S120/S150 List Manual)

General

- r0002 TM41 status display
- p0408 TM41 encoder emulation pulse number
- p0418 TM41 encoder emulation fine resolution Gx_XACT1 (in bits)
- p4099[0...3] TM41 inputs/outputs sampling time
- p4400.0...2 TM41 encoder emulation operating mode
- p4401 TM41 encoder emulation mode
- p4402 CO/BO: TM41 encoder emulation status
- r4419 TM41 encoder emulation diagnostics position setpoint

Incremental encoder emulation using a speed setpoint (p4400 = 0)

- p0840 BI: ON/OFF (OFF1)
- r0898.0...13 CO/BO: Control word sequence control infeed
- r0899.0...15 CO/BO: Status word, sequence control
- p1155 CI: TM41 encoder simulation speed setpoint 1
- p4426 TM41 encoder emulation pulses for the zero mark

Incremental encoder emulation using the encoder actual position (p4400 = 1)

- p4408 TM41 encoder emulation pulse number leading encoder
- p4418 TM41 encoder emulation fine resolution leading encoder
- p4420 CI: TM41 encoder emulation position setpoint
- p4421 TM41 encoder emulation dead time compensation
- p4422 TM41 encoder emulation position setpoint inversion
- p4426 TM41 encoder emulation pulses for the zero mark

7.25 Upgrade the firmware and project

7.25.1 Overview

The firmware must be upgraded, if in a more recent firmware version, an extended functional scope is available that you would like to use.

In principle, upgrading the firmware functions the same for both the CU310-2 and the CU320-2. Projects cannot be transferred between a CU310 or CU310-2 and a CU320 or CU320-2.

The firmware for the SINAMICS drive system is distributed in the system. It is installed on the Control Unit and in every individual DRIVE-CLiQ component.

When it powers up, the Control Unit automatically takes its firmware from the memory card. As a consequence, it does not have to be specifically upgraded. By updating the firmware on the memory card via the web server, the firmware of the Control Unit is upgraded automatically.

Requirement for safe upgrading is a new memory card as of Runtime version V4.6. This memory card has more memory and thus enables the duplication of the data as a backup copy. An adapted boot loader is also included on the new memory card. Older memory cards still function, but prevent a safe upgrade.

WARNING

Danger to life through software manipulation when using removable storage media

The storage of files on removable storage media involves a high risk of infection, e.g. via viruses or malware. As a result of incorrect parameterization, machines can malfunction, which in turn can lead to injuries or death.

- Protect the files on removable storage media against harmful software through appropriate protective measures, e.g. virus scanners.

Note

Make sure that you use a memory card that is suitable for the current firmware version (e.g. V4.8). You can see if the memory card is suitable for a safe upgrade on the label.

DRIVE-CLiQ components

The firmware of the DRIVE-CLiQ components is also provided on the memory card of the Control Unit. With the factory setting p7826 = 1, it is automatically transferred from the memory card to the DRIVE-CLiQ components when commissioned for the first time. When upgraded, the firmware is saved (non-volatile) in the DRIVE-CLiQ components.

Once the project has been downloaded or automatic configuration has been carried out, the firmware is automatically upgraded on all the connected DRIVE-CLiQ components. This upgrades all DRIVE-CLiQ components to the firmware releases that match the memory card.

Update

This operation can take several minutes. This is indicated by the RDY-LED on the corresponding components flashing green/red and the Control Unit RDY-LED flashing orange at 0.5 Hz.

Parameter p7827 indicates the progress.

The update has been completed if the RDY-LED on the Control Unit stops to flash at 0.5 Hz. Once the update process has been completed, the RDY-LED of the respective component goes into a steady light condition, for which the upgrade has been completed and the new firmware has been activated. For the components for which the RDY LED flashes green/red at 2 Hz you must perform a POWER ON to activate the new firmware.

Note

When activating the new firmware, it is possible that a component interrupts cyclic communication. Communication problems will then occur that you must acknowledge.

For individual components, STARTER dialogs ("Drive Unit" -> "Configuration" -> "Version Overview") can be used to read the firmware version or start a firmware upgrade manually for specific components. The versions of the DRIVE-CLiQ components and that of the Control Unit can also differ. Information can be found in the version overview.

Note

DRIVE-CLiQ components with higher firmware releases are downwards compatible and also operate with DRIVE-CLiQ components that have lower firmware releases.

Note

Upgrade for SINAMICS S120 chassis

Upgrading S120 chassis devices is more complex and involves more settings than for booksize devices. You can find a detailed description of the procedure when upgrading chassis devices at the following SIEMENS internet site

Upgrading S120 chassis devices
(<https://support.industry.siemens.com/cs/ww/en/view/60494864>)

7.25.2 Updating the firmware via the Web server

7.25.2.1 Overview

You can update the data on your memory card directly via an Internet connection with the aid of the network connection. You can use this to transfer configuration data and the latest firmware to the memory card.

For safety reasons, the current data is not directly overwritten when you update the data on the memory card. There is a double data storage via a backup partition. In this way, damaged data can be restored automatically after an automatic test in the event of a fault.

7.25.2.2 Updating firmware/configuration on the memory card

You can load a firmware or a configuration to the memory card of the drive with the aid of the Web server. If required, firmware and configuration can be loaded at the same time.

Requirements

- Existing drive project
- Web server has been started
- Firmware or configuration is packed in a zip archive
- PG/PC is connected to the Control Unit (target device)
- STARTER: "Download to file system" has been carried out

Calling the Manage config display area

Click the "Manage config" entry in the navigation.

The "Manage config" area is then displayed on the right in the Internet browser.

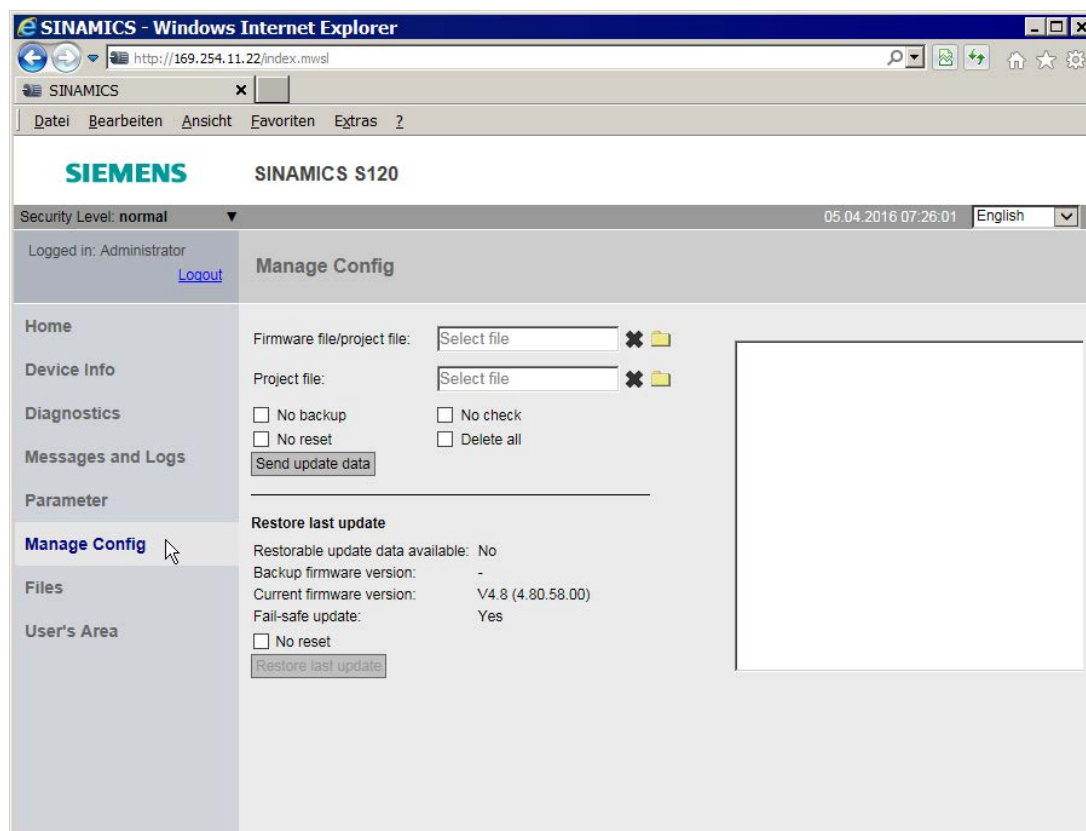



Figure 7-24 Web server display area: Manage config; the status on the right is only displayed following an action

You can send new data or restore the previous update via this display area.

Updating the firmware or configuration

You can update the firmware and a configuration separately via a zip file. The configuration data must have been zipped via STARTER (using the "Load to file system" function).

 WARNING
Danger to life through software manipulation when using removable storage media
The storage of files on removable storage media involves a high risk of infection, e.g. via viruses or malware. As a result of incorrect parameterization, machines can malfunction, which in turn can lead to injuries or death.
<ul style="list-style-type: none"> • Protect the files on removable storage media against harmful software through appropriate protective measures, e.g. virus scanners.

Firmware and configuration can also be updated together. For this reason, the "Select file" field is present twice. The following description refers to the separate update of the firmware or the configuration:

1. Click the  folder icon to the right of the "Select file" field.
2. Select the zip file of the new firmware or configuration in a directory of the Web client.

The name of the firmware or the configuration file is then displayed in the "Select file" field.

The following options are offered for the subsequent update:

Option	Description
No backup	The existing firmware/configuration is not saved before the update.
No test	The firmware/configuration in the downloaded archive is not checked for consistency.
No reset	A reset of the firmware/configuration is not initiated after the download.
Delete all	All files are deleted on the memory card before the archive is unpacked. Note: Activate this option only when updating the firmware. Important data would be destroyed with this option when updating the configuration. NOTICE: loss of data, Only the "/install/sinamics" directory and the license key are then retained.

3. Select all the required update options by clicking.
4. Click the "Send update data" button.

During the update, a check is made as to whether there is sufficient free space on the memory card. The state of the drive objects of the Control Unit is also checked.

- As long as the configuration update is running, fault "F01070 project/firmware download to the memory card in progress" is output by SINAMICS.
- As soon as partition 1 and partition 2 are not consistent with each other, the following alarm is output "A01073 POWER ON for backup copy to memory card required".

In both cases an entry is made in the diagnostic buffer of the Control Unit.

Note

The firmware download to the memory card can take several minutes.

Restoring the last update

The current firmware version is displayed at "Restore last update" in the "Manage config" area. If an older version of the firmware is available as a backup, this version is also displayed with its ID and in this case, you can downgrade the firmware back to this backup version.

1. If a reset is not to be initiated when restoring the last version, activate the "No reset" checkbox.
2. Click on the "Restore last update" button.

Result:

The last version of the firmware is then restored. This downgrading to the last update also includes the use of old project data or passwords, which were valid for the previous firmware version.

7.25.3 Updating the firmware

Requirements

- An existing drive project
- A memory card with the latest firmware
- The STARTER commissioning tool with new firmware on the programming device (PG/PC)
- PG/PC is connected to the Control Unit (target device)



WARNING

Danger to life through software manipulation when using removable storage media

The storage of files on removable storage media involves a high risk of infection, e.g. via viruses or malware. As a result of incorrect parameterization, machines can malfunction, which in turn can lead to injuries or death.

- Protect the files on removable storage media against harmful software through appropriate protective measures, e.g. virus scanners.

Updating the firmware via the Web server to the latest version

1. Update the data on the memory card:
 - Start the Web server (Page 410)
 - Transfer the firmware via the Web server to the memory card (Page 387)

After the update of the data on the memory card, the new data is unzipped and checked automatically. A reset is then triggered.
2. The firmware for the DRIVE-CLiQ components is automatically updated. A new reset is triggered.

The new data is then duplicated on a backup partition of the memory card, so that in the event of damage to the data the duplicate can be accessed (see Chapter Protection against power failure (Page 392)).
3. POWER ON of the drive unit (Control Unit and all DRIVE-CLiQ components).

After the complete power up, the new firmware version is active in the DRIVE-CLiQ components and subsequently displayed in the version overview.

Updating the firmware from the memory card to the latest version

Note

Backing up web server settings

In order that your specific web server settings remain after upgrading the firmware, before upgrading, backup the configuration data and then load them again after the upgrade has been completed.

Backup the data to this directory on the memory card:

`\OEM\SINAMICS\HMI\`

1. Open the project in STARTER (this step is not required if the project is already in STARTER):
 - Connect to the target system (online mode).
 - Load the project from the target system into the PG/PC.
 - Disconnect from the target device (offline mode).
2. Convert the project in STARTER to the current firmware version:
 - In the project navigator, select menu "Drive unit" > "Target device" > "Update device version / device type"
 - Then select the required firmware version: e.g. version "SINAMICS S120 firmware version 4.x" > "Change version"
3. Replace the memory card:
 - Disconnect the Control Unit from the power supply.
 - Remove the memory card containing the old firmware version.
 - Insert the memory card containing the new firmware version.
 - Switch on the Control Unit again.
4. Wait until the Control Unit has completed the transfer of the new firmware. This is signaled at the diagnostic RDY LED.
5. Using the backed up memory card data with the old firmware, overwrite the following directory on the actual memory card:
`\OEM\SINAMICS\HMI\`
6. Transfer the project from STARTER to the new hardware:
 - Connect the new hardware with the PG/PC.
 - Connect to the target system (online mode).
 - Download to the target device.
7. Then carry out a "Copy RAM to ROM...".
8. Carry out a POWER ON for the drive unit (Control Unit and all DRIVE-CLiQ components).
After the complete power up, the new firmware version is active in the DRIVE-CLiQ components and subsequently displayed in the version overview.

7.25.4 Downgrade lock

The downgrade lock prevents the downgrade of firmware upgrades that have already been performed to correct errors.

Note

Upgrade higher firmware versions

Components with higher firmware versions are fully downwards compatible with components with lower firmware versions. Following a firmware upgrade, a component will also operate without restrictions with components that have a lower firmware version.

Note

Firmware retrofit of a Control Unit

A higher firmware version is also characterized by having a larger range of functions than a lower firmware version. If you downgrade a Control Unit from a higher to a lower firmware version, it is possible that certain functions will no longer be available.

7.25.5 Protection against power failure while updating via the Web server

To ensure data protection against power failure updating via the Web server, as of firmware V4.6, the data on the working partition is duplicated on the memory card on the backup partition. This ensures that when you update the data on the memory card a data loss cannot occur due to a fault. Only the system can access this backup partition. The partition is not visible for users.

Note

Minimum requirements

Use of this feature is not possible with memory cards of older firmware versions (e.g. V4.5). The following requirements must be satisfied for working with automatic backup copies:

- a Control Unit with the correct version (see "Reading off CU version (Page 940)")
 - an original memory card for firmware version V4.6 or higher
-

Amended data on the memory card

If the data on the working partition of the memory card and the backup partition is no longer consistent, the warning "A01073: POWER ON for backup copy on memory card required" is emitted. In this case, an entry is made in the diagnostic buffer of the Control Unit. A POWER ON must therefore be performed to update the data on the backup partition.

Automatic restoration of defective data

If defective data is detected on the memory card, the system automatically restores the relevant data. If, for example, the working partition of the memory card is damaged, this partition is reformatted and restored with the data of the backup partition. In this case the message "F01072: memory card recreated from backup copy" is emitted.

7.26 Pulse/direction interface

Thanks to the pulse/direction interface, in the SERVO and VECTOR control modes, SINAMICS S120 can be used for simple positioning tasks on a controller.

- The encoder interface of the SMC30 (connector X521) is used to connect the controller to the CU320-2.
- The internal encoder interface at connector X23 is used to connect the controller to the CU310-2.

The controller enters the setpoints for the pulse/direction signals to the drive via the encoder interface.

The specified actual speed value r0061 can then be connected as speed setpoint to the fixed setpoint p1155 via BICO.

Note

- More information on the Control Unit CU320-2 and the SMC30 is provided in the SINAMICS S120 Control Units Manual.
 - More information on the Control Unit CU310-2 is provided in the SINAMICS S120 AC Drive Manual.
-

Application: Speed-controlled drive

The drive is subject to speed control when operating on the controller. The clock frequency stipulates the speed setpoint. The pulse number is entered in p0408. This is calculated from the clock frequency of the controller and the preferred maximum motor speed. The following formula applies:

$$\text{Pulse number} = (\text{max. clock frequency} \cdot 60) / \text{max. speed}$$

Example: If the controller has a maximum clock frequency of 100 kHz and the motor being used is to run at its maximum rated speed of 3000 rpm, the resulting pulse number will be 2000.

Wiring the SMC30 input signals

The input signals for the pulse/direction interface are wired via connector X521 of the SMC30:

Table 7- 15 Wiring the SMC30

Pin	Signal name	Technical specifications
1	Pulse	–
2	M	Ground
3	Direction of rotation	–
4	M	Ground
5 ... 8	Not relevant	–

Wiring the CU310-2 input signals

The input signals for the pulse/direction interface are wired via connector X23 of the CU310-2:

Table 7- 16 Wiring the CU310-2

Pin	Signal name	Technical specifications
1 ... 11	Not relevant	–
12	M	Ground
13	Direction of rotation	–
14	M	Ground
15	Pulse	–

Settings in the configuration wizard

Make the settings for the pulse/direction interface (rotary, 24 V, terminal, no track monitoring, no zero mark, etc.) in the STARTER configuration wizard in the "Encoder Data" dialog box.

Note

The pulse/direction interface is activated using p0405.5 = 1 (e.g. via the Expert list of STARTER).

Overview of important parameters (see SINAMICS S120/S150 List Manual)

- p0010 Drive, commissioning parameter filter
- r0061 CO: Actual speed value unsmoothed
- p0400[0...n] Encoder type selection
- p0404[0...n] Encoder configuration active
- p0405[0...n] Square-wave signal encoder A/B track
- p0408[0...n] Rotary encoder pulse No.
- r0722.0...21 CO/BO: CU digital inputs, status
- p0738 BI: CU signal source for terminal DI/DO 8
- p0739 BI: CU signal source for terminal DI/DO 9
- p2530 CI: LR position setpoint
- p2550 BI: Position control enable 2

7.27 Derating function for chassis units

An adapted derating function greatly reduces the noise produced by chassis format power units (Motor Modules and Power Modules) and enables operation at a multiple of the rated pulse frequency at nearly rated current. This is achieved by monitoring the temperature difference between heat sink and chip using temperature sensors. When the operating temperature threshold is exceeded, the pulse frequency or permitted current limit, respectively, is automatically reduced.

This enables the maximum output current of the power unit to be achieved even at high pulse frequencies. The derating curve becomes effective at a later point.

The derating function is effective for Motor Modules and Power Modules in the chassis format. Units that are connected in parallel operate in the same manner as single units. The dependency of the output current on the pulse frequency for the chassis power units is described in the SINAMICS S120 Chassis Power Units Manual.

Operating principle

In order to optimize the use of the power unit also at temperatures below the maximum permitted ambient temperature, the maximum output current is controlled as a function of the operating temperature. This function also accounts for the dynamic response of the thermal performance (rise and decay curves of the operating temperature).

An alarm threshold is calculated that is weighted with the current ambient temperature.

By weighting the alarm threshold with the current ambient temperature, the power unit can output higher currents close to nominal current even at lower ambient temperatures.

Depending on the setting of parameter p0290 "Power unit overload response", the pulse frequency or the current will be reduced, or no response will occur if the alarm threshold is exceeded. An alarm (e.g. A07805 "Infeed: Power unit overload") is generated even if no response is desired.

The following quantities can result in a response to thermal overload:

- Heat sink temperature via r0037[0]
- Chip temperature via r0037[1]
- Power unit overload after I_{2t} calculation via r0036

Possible measures to avoid thermal overload:

- For servo control, reduce the output current (closed-loop speed/velocity or torque/force)
- Reduction of the output frequency for V/f control.
- Reduction of the pulse frequency for vector control.

Parameter r0293 "Power unit alarm threshold model temperature" indicates the temperature alarm threshold for the difference between the chip and heat-sink temperatures.

7.28 Parallel connection of motors

For simple commissioning of group drives (a number of identical motors operating on one power unit), the number of parallel-connected motors can be entered via STARTER (only for vector control) or via the expert list (for servo and vector control) (p0306).

An equivalent motor is computed internally depending on the number of motors specified. The motor data identification determines the data for an equivalent motor. For a parallel connection, operation with encoder (at the 1st motor) is also possible.

Note

For information about parallel connection of Motor Modules, see Section "Parallel connection of power units (Page 526)".

Features

- Up to 50 motors connected in parallel can be operated on one frequency converter.
- The original motor data set (p0300 ff.) is not modified. It is merely the data set transfer to the closed-loop control which is organized according to the number of parallel-connected motors.
- The stationary motor data identification also works for parallel connections.
- The rotating measurement function also works if the motors can rotate without distance limit. Uneven loading of the motors or a high degree of gear backlash will negatively affect the accuracy of the rotating measurement result.
- The cable lengths for motors connected in parallel must be as symmetrical as possible to afford the most even possible distribution of current among individual motors.
- Motors connected in parallel with servo control, must be individually thermally monitored. Synchronous motors connected in parallel must have the same EMF so that no unwanted currents flow between the motors.

Commissioning via STARTER for vector control

Note

Motors with servo control can only be connected in parallel via the expert list.

Parameter p0306 is assigned in a STARTER commissioning screen. When the subsequent parameters are set, p0306 is included in the calculation of the current limit (p0640) and in the reference current (p2002). Parameter p0306 has a value range of 1 to 50, and is it dependent on the motor data set (MDS).

1. To connect motors in parallel, select the corresponding motor in the selection screen and activate the "Parallel motor connection" option.
2. Enter the number of motors in the parallel connection in the entry field "Number".

This display and input function is available for vector control only. For servo control, the parallel connection of motors can only be configured using the expert list (parameter p0306).

Motors with integrated DRIVE-CLiQ interface (SINAMICS Sensor Module Integrated) can also be connected in parallel. The first motor is connected to DRIVE-CLiQ via the encoder. The additional motors must be identical. Using parameter p0306 and the encoder information obtained via DRIVE-CLiQ, it is possible to determine all the necessary motor data.

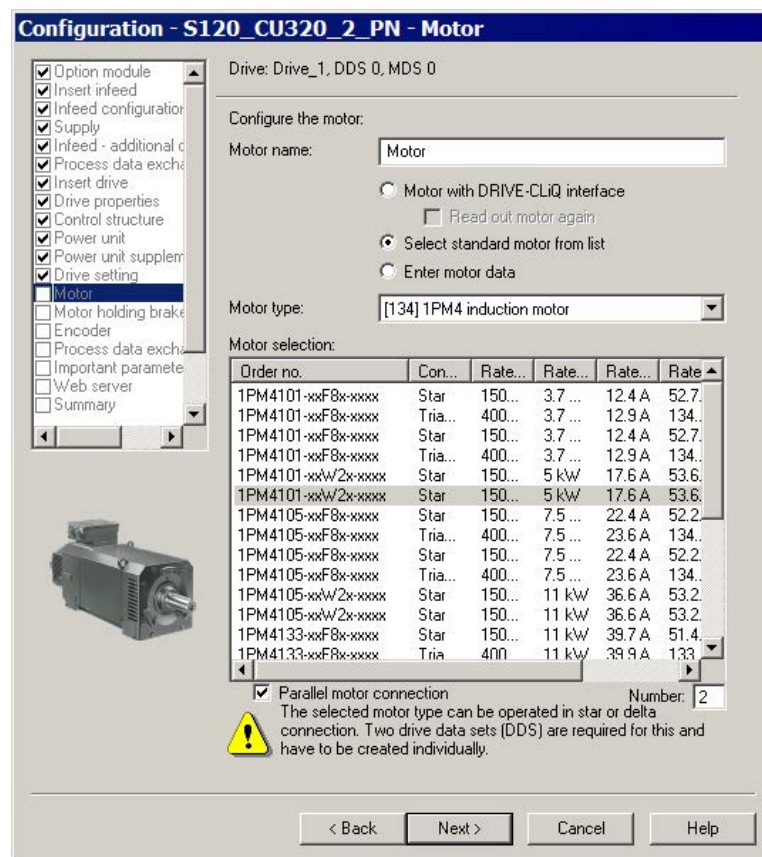

Figure 7-25 Parallel motor connection selection for vector control

Properties of the parallel connection in STARTER

- The rating plate and equivalent circuit diagram parameters are those of the single drive.
- The parallel data set has no code numbers. All motor data is calculated from p0306 and the code numbers of individual motors. The same interlock mechanisms apply as to single drives.
- The "Motor data" screen still displays only the data for the individual motor selected.

Restrictions applicable to parallel connections

The basic governing principle of parallel connections is that the motors involved are mechanically inter-coupled via the load. Where motors need to be decoupled from the connection, the number of motors need to be reduced in p0306 by a DDS/MDS changeover. Since the equivalent circuit diagram changes as a result, it may be necessary to commission these data sets separately (e.g. motor data identification with reduced number of motors). The power unit will otherwise apply false motor data.

An EDS changeover and, e.g. two SMCs must be used in cases where a motor with encoder needs to be decoupled from connections operating with encoder.

Vector control with encoder for parallel-connected drives functions in the same way as for a single drive if the drives are coupled via the load and the speeds do not differ by more than the working-point-dependent pull-out slip.

Counter-example:

The gear ratios used to couple the motors with the load are large and the backlash and elasticity in the drive train are therefore high. If the load then causes one of the motors to rotate, but the other is still stationary, the drive without an encoder will stall.

If a motor is defective, the individual motor will be shut down on overcurrent by the motor circuit breaker. The power unit will be shut down by the control (if available) or, in the case of a turn-to-turn fault in the motor, the power unit will go into the fault condition. The motor must then be decoupled from the parallel grouping. Parameter p0306 is changed by the DDS/MDS changeover.

Overview of important parameters (see SINAMICS S120/S150 List Manual)

- p0300[0...n] Motor type selection
- p0306[0...n] Number of motors connected in parallel:
- p0307[0...n] Rated motor power
- p0640[0...n] Current limit
- p2002 Reference current

7.29 Web server

7.29.1 Overview

The Web server provides information on a SINAMICS device via its Web pages. Access is via an Internet browser. The information on the Web pages is shown in German or English. For information about message texts, drive object states and parameter names, there is a language selection which allows a switchover of the display to the desired language (German, English, Chinese, Italian, French, Spanish).

The most important functions of the Web server are described below. However, the "User's area" display area of the Web server is described in detail in a separate document (see "User-defined Web pages"). For this reason, this display area is not described in this manual.

Note

Total memory size of user files

The sum of the data stored via the Web server must not exceed the total memory size of 100 MB. The total memory size of the stored data influences the backup times. The larger the data quantity, the longer the backup takes.

Configuration

The basic configuration of the Web server is performed either via the STARTER or during the first commissioning. The Web server is active by default in the factory setting of the drive.

Data transfer

In addition to the normal (unsecured) transmission (HTTP), the Web server also supports secure transmission (HTTPS). With the input of the appropriate address, you can decide yourself whether a normal or secure transmission is used to access the data.

For safety reasons, secure transmission can be forced by deactivation of the HTTP port.

Access rights

The normal protection mechanisms of SINAMICS apply for the Web server, including password protection. Further protective mechanisms have been implemented especially for the Web server. Different access options have been set for different users, depending on the function. The parameter lists are also mostly protected so that only users with the appropriate rights can access or change the data.

User-defined Web pages

You can extend the standard Web pages for the Web server using some self-created Web pages.

More detailed information can be found in the SINAMICS S120 programming manual "Web server – User-defined pages".

7.29.2 Requirements and addressing

Preconditions

The Web server is available for all CU310-2 and CU320-2 Control Units via the LAN interface (X127). For Control Units with PROFINET interface, the Web server is also available via this interface.

Addressing

The individual drives are addressed in the Web server via the IP address. An assignment to a symbolic name (e.g. "Roller drive 1") can only take place outside the drive using your IT infrastructure. A cancellation of the symbolic name in the drive is not possible.

The IP address can be taken from the CU parameter assignment. Example:

- Integrated Ethernet interface (X127): r8911
- PROFINET interface (X150): r8931

The commissioning tools (STARTER, SCOUT, etc.) can also be used to determine and allocate IP addresses.

As delivered, the integrated Ethernet interface has IP address 169.254.11.22.

Supported Internet browsers

In the current version, the SINAMICS Web server supports large displays such as on usual PC screens.

Access to the Web server is possible with the following Internet browsers:

- Microsoft Internet Explorer 8
 - only on Windows XP Professional SP3 32 bit
 - only functions already available in SINAMICS runtime V4.7 (exclusive file and folder handling)
 - No longer any support in future SINAMICS Firmware versions
- Microsoft Internet Explorer 11
- Microsoft Edge
- Mozilla Firefox 45
- Google Chrome 49

7.29.3 Configuring the Web server

7.29.3.1 Performing the basic configuration

The configuration of the Web server is performed via the "Configure Web Server" dialog box of STARTER. Basically, the configuration can be performed in online mode as well as in offline mode of STARTER.

Alternatively, you can also configure the Web server via the expert list using the appropriate parameters. The configuration parameters for the Web server can be found in the SINAMICS S120/S150 List Manual. Parameter p8986 activates the Web server.

Calling the configuration dialog of the Web server

1. Select the required drive in the project navigator.
2. Call the "Web server" context menu.

The "Web Server Configuration" dialog box then opens.

Default settings of the Web server

The Web server is activated per default in the configuration.

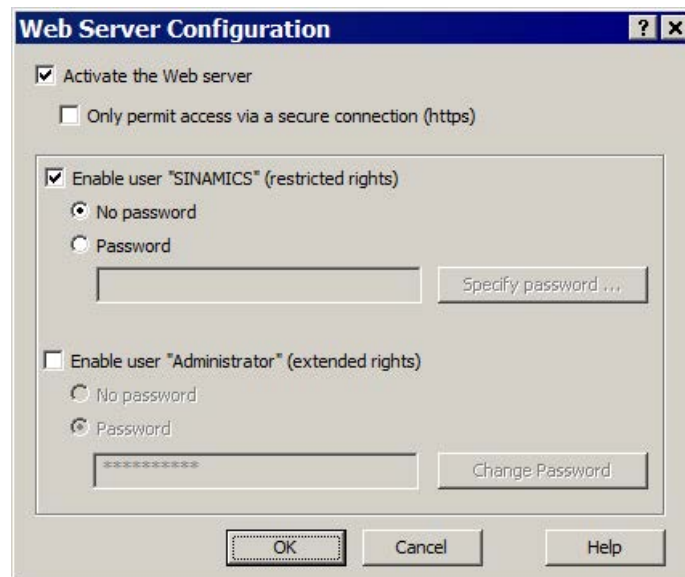

Figure 7-26 Configuring the Web server with default settings

Deactivating the Web server

1. Deactivate the "Activate Web server" checkbox in the configuration dialog box.
2. Click "OK" to close the configuration dialog box and accept the settings.

Restricting Web server access to a secure connection

Using the default configuration of the Web server, you can access the SINAMICS frequency converter via an HTTP connection as well as via the encrypted HTTPS connection. Using the configuration, access can be restricted so that only the secure HTTPS connection is possible.

NOTICE
Using non-encrypted connections (HTTP)
When using the HTTP protocol, the login data is also sent unencrypted. This facilitates password theft attacks, for example, and can lead to data manipulation by unauthorized parties and thus ultimately to damages.
<ul style="list-style-type: none">• Limit access to secure connections so that all data is transferred encrypted.

The configuration option provided to limit connections to HTTPS can only be changed when the Web server is active.

- In the STARTER configuration dialog (see image "Configuring the Web server with default settings")
- in the Web server prior to commissioning
- via parameter p8986

Procedure:

1. In the configuration dialog box, activate the "Only permit access via secure connection (HTTPS)" checkbox.
2. If you do not want to assign passwords for read and write access (see Section "Assigning a password (Page 403)"), click "OK".

The basic configuration of the Web server is then completed.

7.29.3.2 Assigning a password

Requirement

The configuration dialog box for the Web server has been opened in STARTER and the Web server is activated (see Basic configuration (Page 401)).

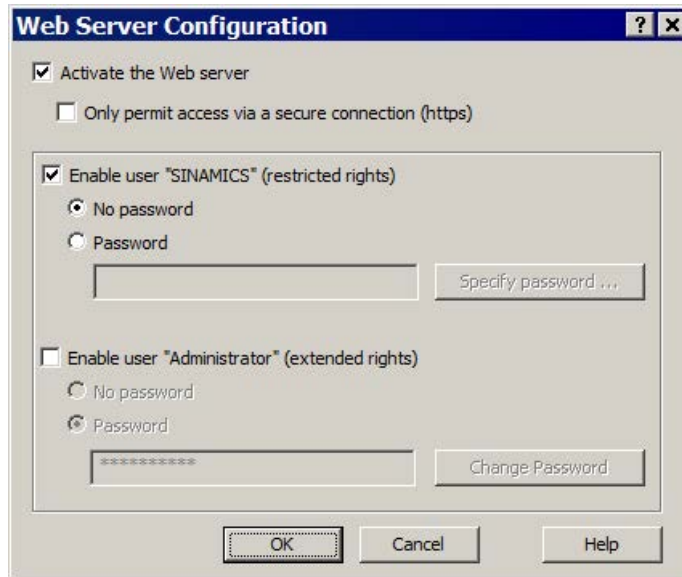

Figure 7-27 Configuring the Web server with default settings

During the first commissioning, the password can also be assigned via the Web server ("Setup" display area). The procedure is identical to the password assignment in STARTER.

Enabling users

The "SINAMICS" and "Administrator" users can be enabled with their specific rights. It is also possible to specify whether a password protection should be active for the "SINAMICS" user. Default settings:

- SINAMICS: No password protection
It is recommended that a password is assigned. This must comprise at least 8 characters.
- Administrator: Password protection (password **is not** pre-selected).
A password with at least 8 characters **must** be assigned. If no password has been assigned, the following warning appears when attempting to login "A09000: Web server security: Administrator password not set".

The "Administrator" user has the full rights as standard. However, only restricted access rights apply for the standard "SINAMICS" user.

Note

Secure passwords

SINAMICS specifies almost no password rules for the assignment of passwords. The only rule is that at least 8 characters are used. You can therefore assign any passwords without restriction. STARTER does not make any checks for illegal characters or passwords which have already been used. Therefore, as the user, you are responsible for the required password security.

Use a sufficiently long password (max. ten characters). Use special characters and avoid passwords which you have already used elsewhere.

Please note that if the Windows language settings are changed, errors can occur when subsequently checking the password. If you use language-specific special characters, you must ensure that the same language setting is active on the computer for subsequent entry of the password.

To enable a user and activate a password, proceed as follows:

1. Click the checkbox of the user you want to enable (e.g. enable "SINAMICS" user, etc.).
2. Click the "With password" option button in the corresponding setting area.
The "Specify password" button below the option button then becomes active.
3. Click the "Specify password" button.

The "Web Server - Specify Password" dialog box opens.

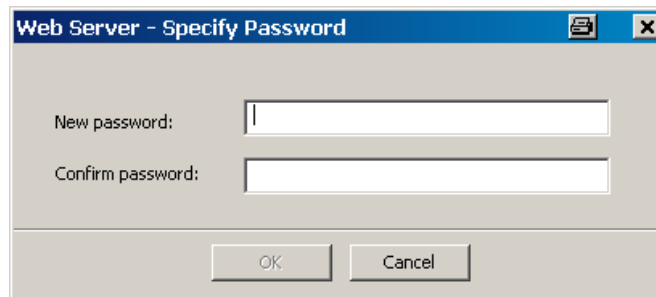

Figure 7-28 Define Web server password ##replace image

4. Enter the new password (max. ten characters) in the "New password" field. Pay attention to upper and lower case.
5. Repeat the input in the "Confirm password" field.

For security reasons, the password entries displayed in the input fields are encrypted.

6. Click "OK" to confirm the input.

If both password entries were identical, the input dialog box is closed. If both entries do not match, the input dialog box remains open and an error message is displayed. At the same time, the two entries in the input dialog are cleared. In this case, you must enter the password again in the two input fields.

The password is queried once when the corresponding Web page is called after this.

Changing the password

A password can be changed at any time. If a password has already been assigned for a user, the existing password is shown in encrypted form.

To change a password, you have to know the existing password.

1. Click the "Change password" button in the user setting area.

The "Web Server - Specify Password" dialog box opens.

2. Enter your old password in the uppermost text box.
3. Enter the new password (max. ten characters) in the "New password" field. Pay attention to upper and lower case.
4. Repeat the input in the "Confirm password" field.

For security reasons, the password entries displayed in the two input fields are encrypted.

5. Click "OK" to confirm the input.

If the password entries were correct, the input dialog box is closed.

Password forgotten?

A forgotten password results in that you can no longer access your previously accessible SINAMICS data and functions via the Web server. Proceed as follows to set a new password:

1. Back up the current configuration of the drive device in the STARTER.

Select the drive unit and call the shortcut menu "Target device > Load CPU/drive unit into PG/PC...".

2. Reset the drive unit to the factory settings.

To do so, select the drive unit and call the shortcut menu "Target device > Restore factory settings".

3. Load the saved configuration back on to the drive unit.

Select the drive unit and call the shortcut menu "Target device > Load to target device".

4. Reconfigure the Web server login for the user in the STARTER.

7.29.4 Access protection and rights

7.29.4.1 SINAMICS access protection

The complete access protection in the web server comprises 3 components:

- SINAMICS Write and know-how protection (Page 1007)

The specified settings of the write and know-how protection - including password protection - also apply for access via the web server to the drive parameters and configuration. The Web server cannot be used to bypass this protection.

An OEM exception list specifies which parameters can also be displayed in the web server, in spite of activated know-how protection.

If access is not possible because of these settings, a corresponding message text is displayed on the Web pages.

- Web server access protection (Page 407)

The Web server access protection can be used to limit access to the users "administrator" and/or "SINAMICS" with the corresponding rights.

It is recommended to use a secure password for both logins.

- Access protection for parameter lists in the web server (Page 409)

Access rights to parameter lists in the Web server can be defined by the "Administrator" user for each parameter list.

For safety reasons, the user "administrator" should never give the user "SINAMICS" the "write" and "change list" rights for the same parameter list at the same time. Otherwise, the user "SINAMICS" would be able to change any chosen parameter to access levels 1-3.

Summary

The most effective access protection is a combination of the aforementioned safety mechanisms.

NOTICE

Manipulation of the frequency converter parameter assignment due to password theft

If unauthorized persons obtain a user's login data, they can manipulate the parameter assignment and cause damage.

- For your drive, activate the know-how protection (see Chapter "Know-how protection (Page 1009)").
- Ensure that especially critical parameters are not included in the OEM exception list.

7.29.4.2 Web server access protection

Both user logins with the following standard rights are available for the SINAMICS Web server:

User	Login name	Function	Standard	rights
User 1	SINAMICS	Diagnostics user	Activated	Read access rights and the right to acknowledge faults.
User 2	Administrator	Parameter assignment user	Deactivated	Access rights to change the system and project and the right to acknowledge faults.

Note

Access rights during the first commissioning

During the first commissioning phase, a login is not required to call the Web server. During this phase, you have full access rights to all functions of the Web server like the "Administrator".

However, the following access rights apply for a commissioned drive:

Functions of the Web server	Access rights		
	All	SINAMICS	Administrator
Start page / password input	X	X	X
Diagnostic pages (version overview, DO state, alarms, diagnostic buffer)	–	X	X
Resetting the fault memory	–	X	X
Uploading trace files	–	X	X
Creating/expanding/removing parameter lists	–	X ¹⁾	X ¹⁾
Reading parameters	–	X ²⁾	X ²⁾
Writing and saving parameters	–	X ²⁾	X ²⁾
Updating the configuration	–	–	X
Updating the firmware	–	–	X
Loading user-defined pages to the drive	–	–	X

1) Only those lists may be edited for which the user has the appropriate access right. A default setting applies during creation depending on the user.

2) These rights can be individually assigned for a parameter list. There is a default setting depending on the user.

Access rights can be set individually for each user and parameter list in the parameter lists via the Web server configuration.

Password assignment

For "SINAMICS" and the "Administrator" users, password protection is regulated as follows by default:

- SINAMICS: No password protection

It is recommended that a password is assigned. This must comprise at least 8 characters.

- Administrator: Password protection (password **is not** pre-selected).

A password with at least 8 characters **must** be assigned. If no password has been assigned, the following warning appears when attempting to login "A09000: Web server security: Administrator password not set".

After the first commissioning, the passwords for the two users can only be defined or changed via the STARTER configuration. With the restoration of factory settings, the passwords are reset to the initial setting (see also Chapter "Assigning a password (Page 403)").

To change a password, you have to know the existing password.

The password is queried once when the corresponding Web page is called.

7.29.4.3 Access protection for parameter lists in the web server

Default rights for parameter lists

Three standard rights are specified for the parameter lists:

Standard right	Explanation
Change list	The user can create, change and delete the list.
Read	The user can read the parameters from the list.
Write	The user can write (and save) the parameters from the list.

The access rights for the parameter lists are predefined as follows:

Situation:	"SINAMICS" rights	"Administrator" rights
"SINAMICS" user creates list	Change list / Read	Change list / Read / Write
"Administrator" user creates list	Read	Change list / Read / Write

You can change the rights of individual parameter lists based on the default settings shown in the table.

- "SINAMICS" and "Administrator" users can reduce their own rights.
- "Administrator" users can reduce the rights of "SINAMICS" users or expand them up to their own level.

Note

For safety reasons, the user "administrator" should never give the user "SINAMICS" the "write" and "change list" rights for the same parameter list at the same time.

NOTICE

Manipulation of the frequency converter parameter assignment due to password theft

If unauthorized persons obtain a user's login data, they can manipulate the parameter assignment and cause damage.

- For your drive, activate the know-how protection (see Chapter "Know-how protection (Page 1009)").
- Ensure that especially critical parameters are not included in the OEM exception list.

Changing access rights to parameter lists in the Web server

1. Start the Web server (see Starting the Web server (Page 410)).
2. Click the "Parameter" entry in the navigation.
The parameter display is then active on the right in the browser. The "Define" tab is displayed.
3. Click the "Define" tab.
All parameter lists are displayed in the "List name" drop-down list.
4. Select the required individual parameter list.
5. Click "Access".
The "Access rights" dialog box opens with the access settings of the parameter list.



Figure 7-29 Access rights

The preset access rights can be seen for the "SINAMICS" and the "Administrator" users. The checkbox is selected for the activated access rights.

6. Activate or deactivate the relevant access rights by clicking the corresponding checkbox.
7. Click "Confirm" to confirm the settings.
The dialog box closes.

7.29.5 Starting the Web server

Requirements

- The Web server is active in the configuration of STARTER (see Basic configuration (Page 401)).
- Functional communication settings
- PG/PC is connected to the Control Unit (target device)

Start

1. Enter the IP address of your SINAMICS drive in the address line of your Internet browser.
Default setting for Ethernet interface (X127): 169.254.11.22.

Note Security

In addition to a normal connection to your drive, secure data transfer via HTTPS is also possible. However, this requires that you use certificates in the browser of your PC (see Certificates for the secure data transfer (Page 428)).

2. Confirm with <Return>.

The start page of the Web server then opens. The most important data of your drive is displayed.

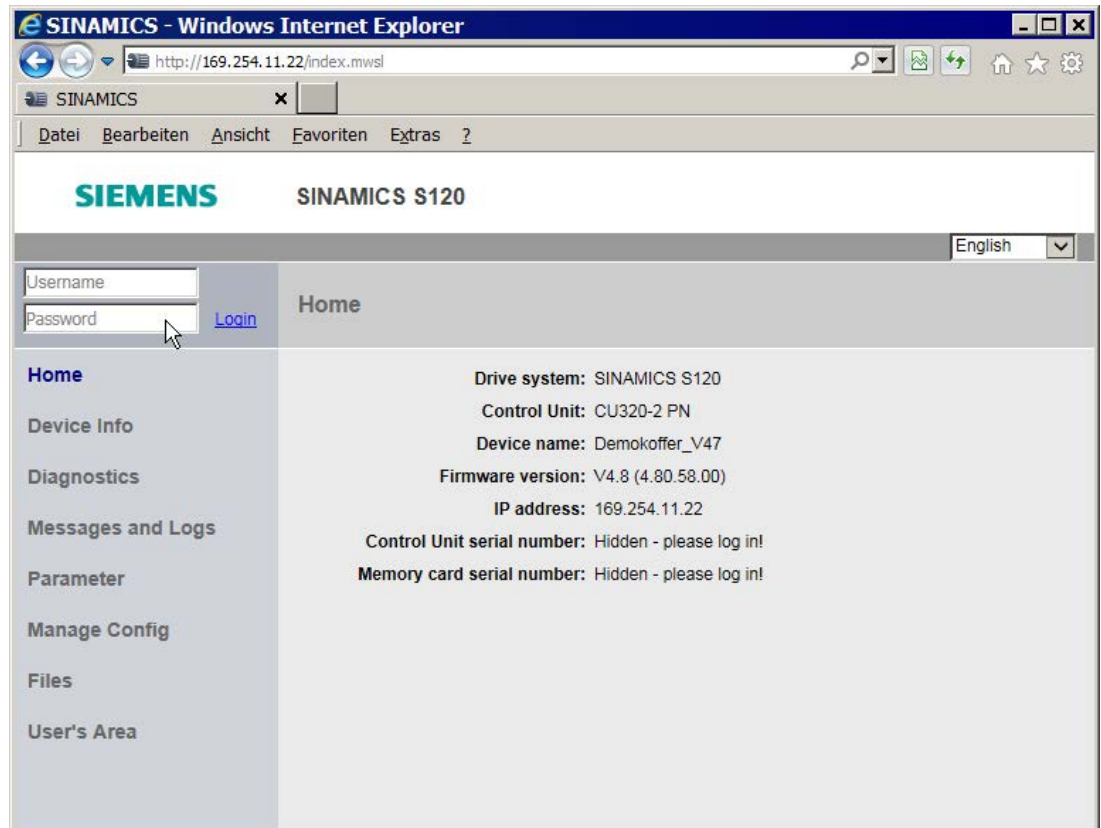

Figure 7-30 Web server start page

3. Enter the login name and password at the top left.
4. Click "Login" to confirm the input.

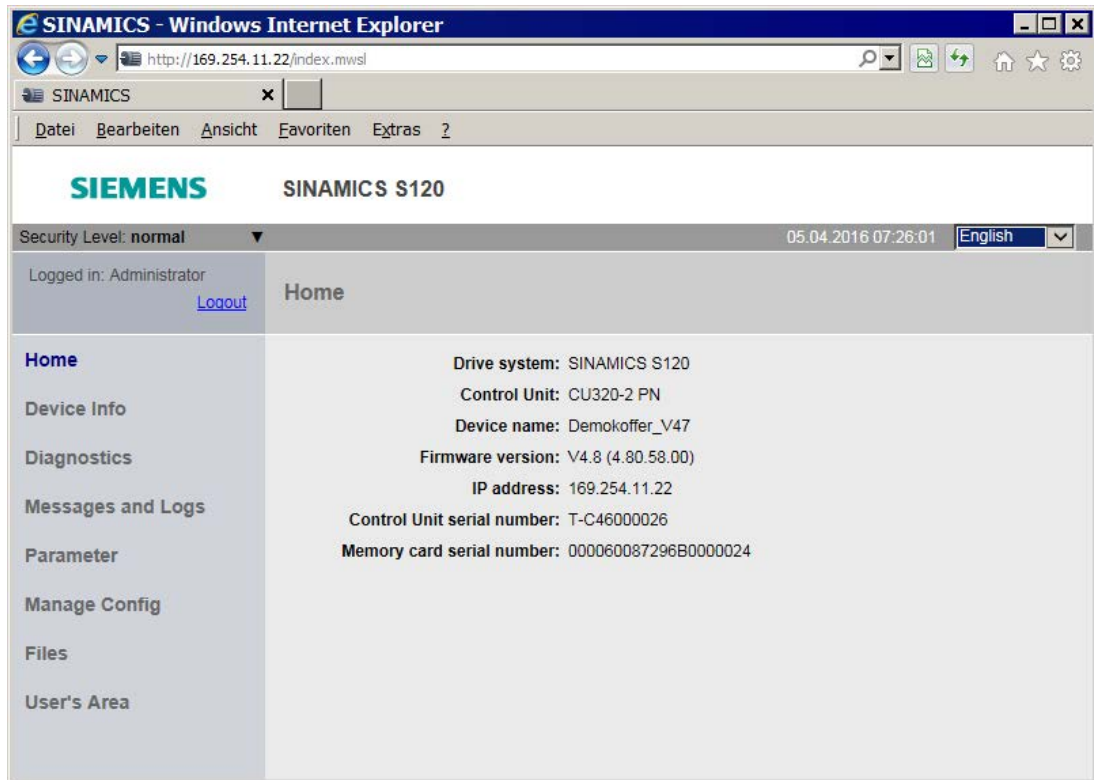

Figure 7-31 Start page after logging in

After logging in you can call other display areas.

Areas of the Web server display

The display of the Web server is divided into two main areas:

- Navigation

You can select the various display areas directly by clicking in the navigation.

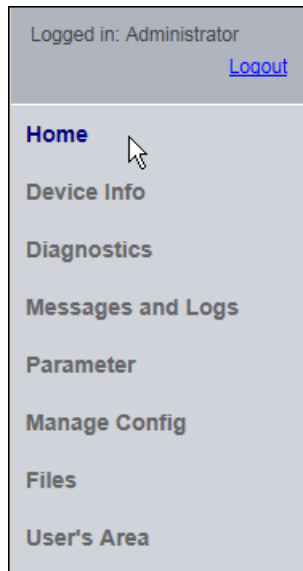

- Display area

Different information is displayed in the various areas. Example of "Parameter". The display is divided further by tabs in the various display areas. The name of the display area is shown at the top.

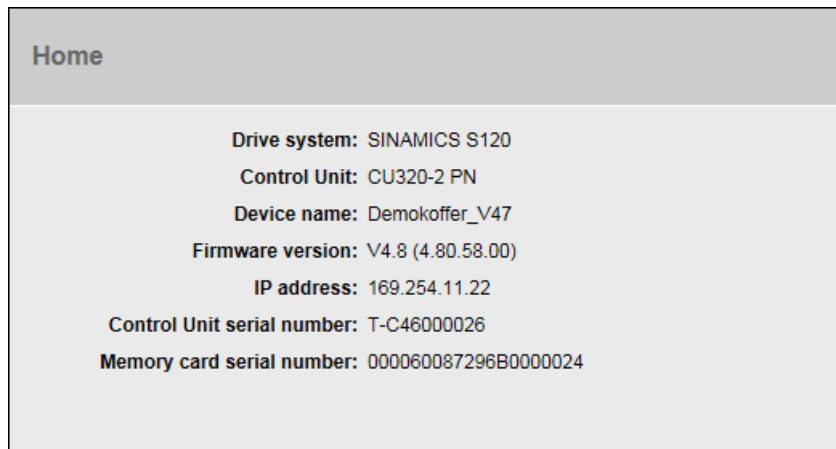

Logout

If you no longer require the Web server or want to block the detailed display areas, you should log out for safety reasons.

Click "Logout" at the top left in the navigation.

7.29.6 Displaying device information

The most important device information can be displayed with the aid of the Web server.

Displaying information

Click the "Device information" entry in the navigation.

The most important device information is then displayed in the "Device information" area.

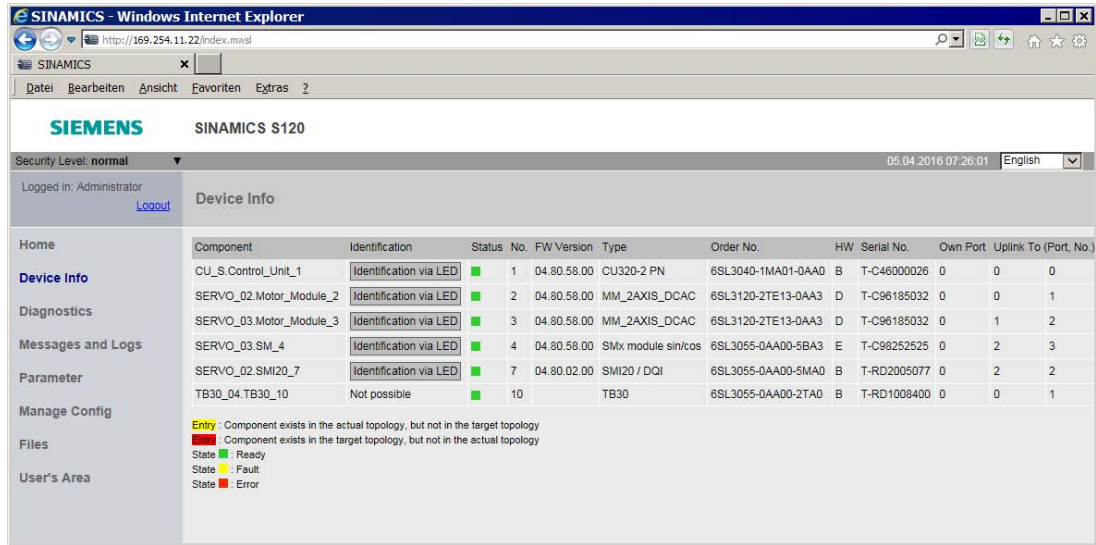

Figure 7-32 Display area: Device information

You can resort the table displayed using the arrow in the column headers.

Identification and status of a component

As with using the STARTER, a system component can also be identified and its status displayed using the Web server.

Column	Description
Identification	Allows a drive object to be identified. If the entry "Identify via LED" is displayed in this column, an LED blink test can be performed on the drive. As soon as you click the entry "Identify via LED", the Ready LED on the corresponding component of the drive starts to blink and the component can thus be identified.
Status	The current status of the component is in this column (r0196). Meaning: <ul style="list-style-type: none"> Red: Fault active Orange: Maintenance urgently required Yellow: Maintenance required Green: Component is OK.

7.29.7 Displaying diagnostic functions

7.29.7.1 Status and operating display of the drive object

The status and operating display of the drive objects can be called with the aid of the Web server.

Displaying the Service overview

1. Click the "Diagnostics" entry in the navigation.
2. Click the "Service overview" tab.

All the drive objects of the drive are listed in the Internet browser.

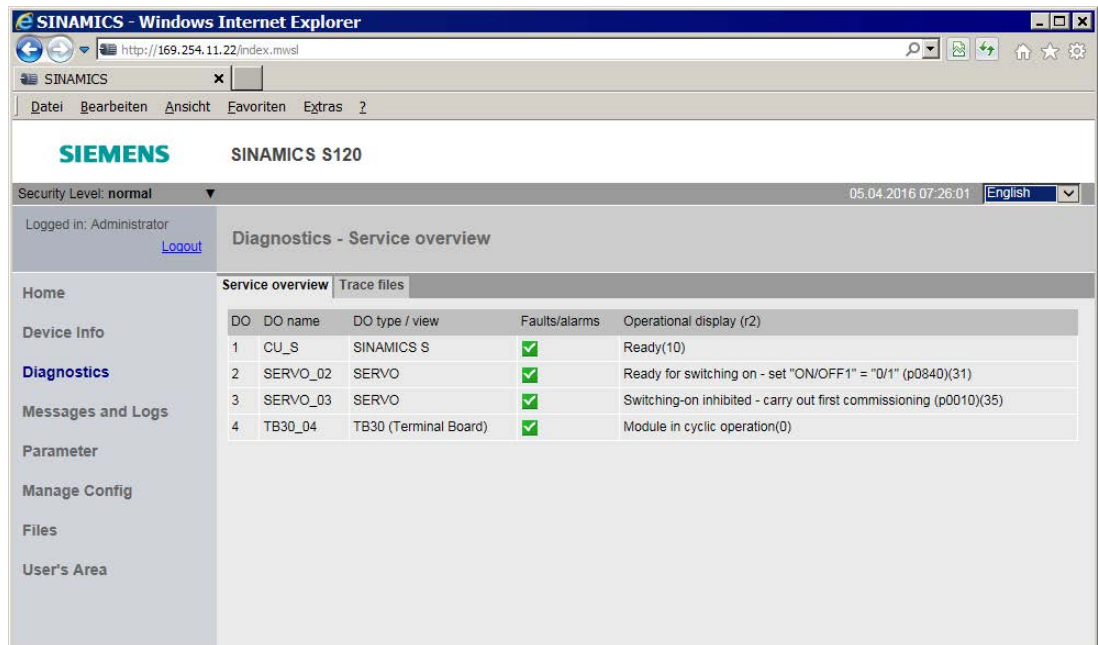

Figure 7-33 Status or operating display of the drive objects

The following information is displayed for each drive object:

Column	Explanation
DO	Number of the drive object.
DO name	Drive object name
DO type/view	Drive object type
Faults/alarms	Graphical display of the status Fault Warning/Maintenance request Maintenance required OK
Operating display	Drive object status (via r0002)

7.29.7.2 Loading a multiple trace

The Web server permits the loading of trace files created using a multiple trace and stored in the memory card of the drive. All the files in the "USER/SINAMICS/DATA/TRACE" directory of the memory card can be loaded to the Web client (i.e. to the PC). The loadable trace files are displayed on the Web page with their name. The trace files can be displayed graphically in STARTER.

Note

Activation and parameterization of the multiple trace

Detailed information for the activation and parameterization of a multiple trace is contained in the "Multiple trace" section of the SINAMICS S120 commissioning manual and in the STARTER online help.

Loading trace files from the memory card

1. Click the "Diagnostics" entry in the navigation.
2. Click the "Trace files" tab.

A list of loadable trace files is then displayed in the "Trace files" tab:

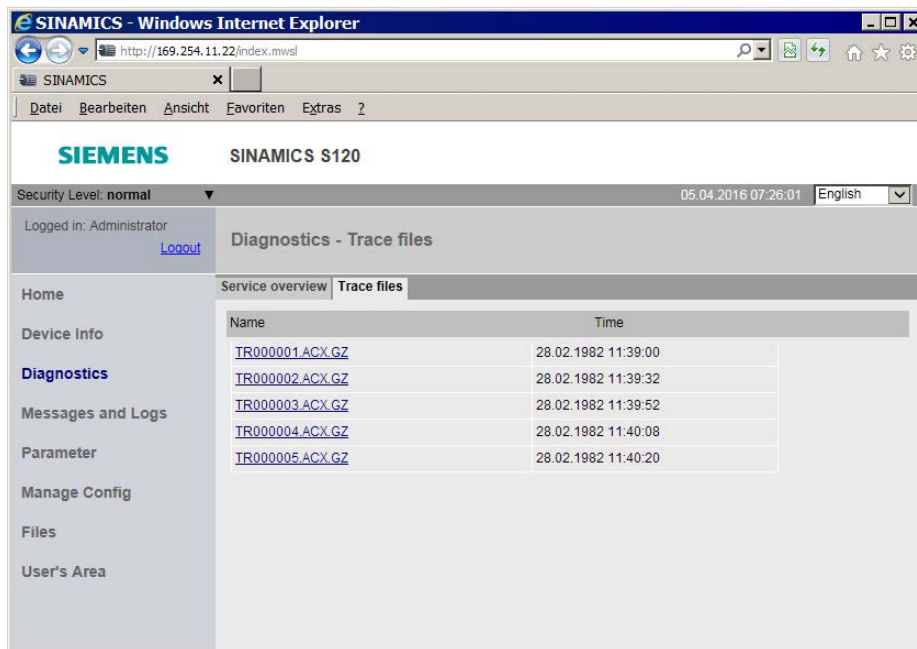

Figure 7-34 Loading trace files

3. In the list, click the name of the trace file that you wish to load.
You are then prompted whether you want to open the trace file or store it in your file system.
4. Save the file in your file system.
The file stored in the file system can be opened with STARTER.

7.29.8 Displaying messages

7.29.8.1 Displaying the diagnostic buffer

You can display the diagnostic buffer with the aid of the Web server.

The diagnostic buffer can be used to log important operating events as a logbook. The diagnostic buffer is in the non-volatile memory, so data written to it can be read out for subsequent analysis of a malfunction (including pre-history).

Note

You can find more detailed information on the diagnostic buffer in the “Diagnostic buffer” chapter of the SINAMICS S120 Commissioning Manual STARTER.

Displaying the diagnostic buffer

1. Click the “Events” entry in the navigation.
2. Click the “Diagnostic buffer” tab.

The diagnostic buffer is then displayed on the “Diagnostic buffer” tab.

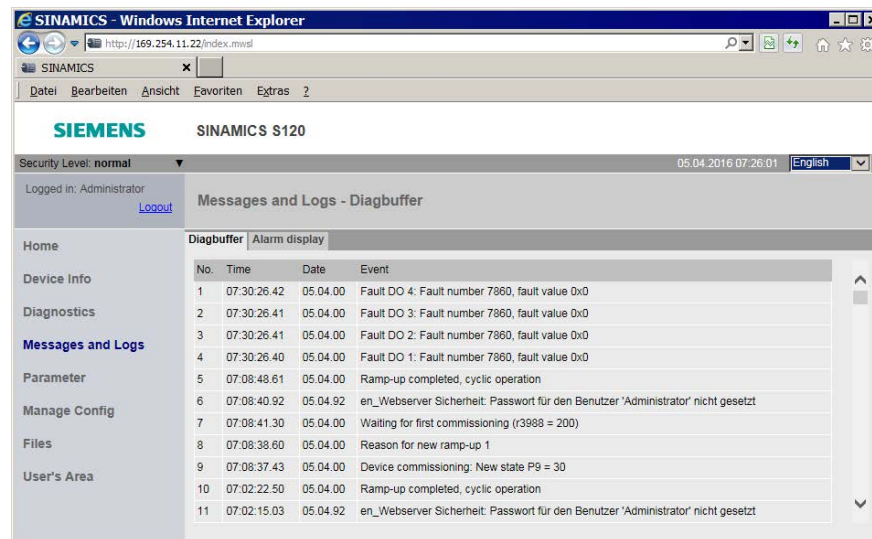

Figure 7-35 Displaying the diagnostic buffer

The following information is displayed:

Column	Explanation
No.	Number of the event
Time	Time of the event Note: No synchronized time is displayed when powering up, but a time comprised of the following components is used instead: "1.1.2000 + Time stamp operating hours".
Date	Date of the event
Event:	Display of the event as text

7.29.8.2 Displaying faults and alarms

You can display and acknowledge pending drive alarms and faults with the aid of the Web server.

Displaying alarm messages

1. Click the "Events" entry in the navigation.
2. Click the "Alarm display" tab.

The current faults and alarms of the drive object are then displayed on the "Alarm display" tab.

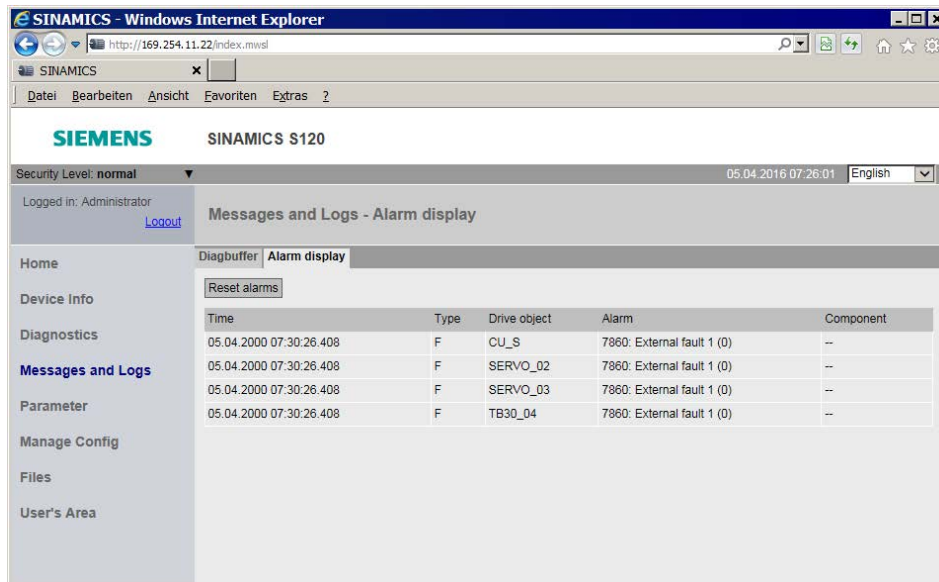

Figure 7-36 Displaying alarm messages

The following information is displayed:

Column	Explanation
Time	Time of the event
Type	Type of the event
Drive object	Relevant drive object
Alarm	Alarm ID (alarm value) with description
Component	Number of the relevant component

The list of alarms and faults is updated automatically. The display can be limited to selected entries in the columns "Type" and "Drive object" using a filter.

3. Click on the "Reset alarms" button.

The faults are acknowledged. The display of the "Alarm display" tab is updated.

7.29.9 Displaying and changing drive parameters

7.29.9.1 Creating a parameter list

Access to all drive parameters is possible with the Web server user-defined parameter lists:

- including DCC and Tec parameters
- including Level 4 parameters if the corresponding password has been set

Up to 20 parameter lists, each with up to 40 parameters, can be managed in the Web server. The created parameter lists are saved on the memory card of the drive. Therefore, a parameter selection performed once is retained for further access even after the drive is switched off.

An existing write and know-how protection also applies without restrictions for parameter access via the Web server.

Note

You can find detailed information about the following parameters in the SINAMICS S120/S150 List Manual in Section "Parameters for write protection and know-how protection":

- Parameters that can be changed with active know-how protection, see Section "Parameters with KHP_WRITE_NO_LOCK"
 - Parameters that can only be read with active know-how protection, see Section "Parameters with KHP_ACTIVE_READ"
-

Creating a parameter list in the Web server

1. Click the "Parameter" entry in the navigation.

The "Parameter" area is then displayed on the right in the Internet browser. The "Define" tab is active when this display area is called.

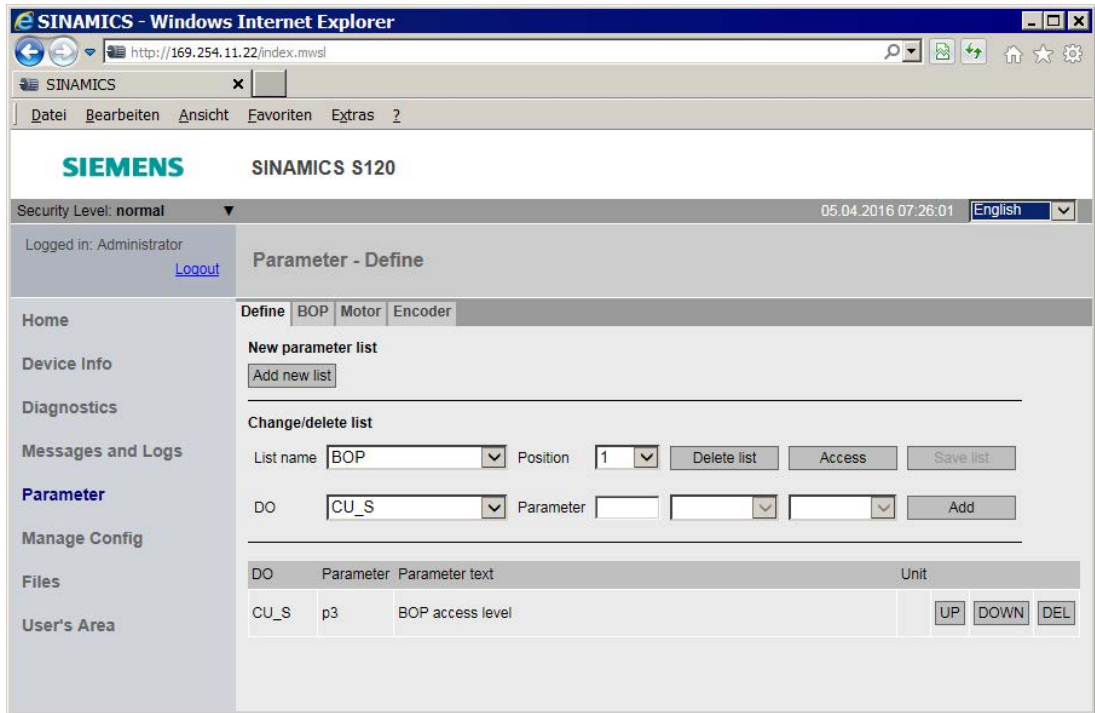

Figure 7-37 Drive parameters - defining the parameter list

2. Click on the "Add new list" button.

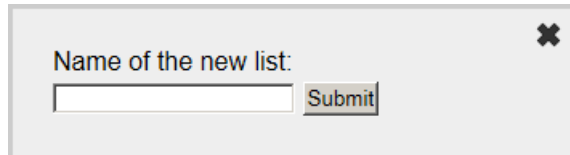

Figure 7-38 Drive parameters - new list

3. Specify a name (without special characters) for the new parameter list and click "Confirm" to confirm the entry.
4. Click the "Access" button and assign the access rights for this parameter list (see Section Access rights for parameter lists in the web server (Page 409)).

5. Select the drive object in the "DO" drop-down list.

Figure 7-39 Drive parameters – creating a parameter list

6. Enter the parameter of the drive object in the following input fields (e.g. 601:0).

- First field: Parameter number
- Second field: Index
- Third field: Bit number

The parameter name is now displayed on the right of the input fields. If the parameter requires no index or bit, the fields remain empty.

7. Click the "Add" button in the parameter list to the right of the first free line.

The parameter is now inserted in the parameter list.

8. Repeat steps 5 to 7 for each parameter that you want to create in the parameter list.

9. Click the "Save list" button to save the parameter list to the memory card of the drive (OEM/SINAMICS/HMI/PARLISTS).

A new tab is created for the new parameter list. The name of the parameter list appears in the tab. You can view the actual parameter values and change them when required via this tab.

10. If you wish to change the order of parameters within the current parameter list, you have two options:

- Move a selected parameter to the desired position in the list using the "UP" and "DOWN" buttons".
- Drag and drop a selected parameter to the desired position in the list.

7.29.9.2 Deleting a parameter list

Either the entire parameter list or individual lines of a selected parameter list can be deleted in the "Parameter" display area of the Web server.

Note

You require the appropriate change rights to delete the selected parameter list (see Chapter "Access rights for parameter lists in the Web server (Page 409)").

Deleting a parameter list

1. Select the parameter list to be deleted in the "List name" drop-down list.

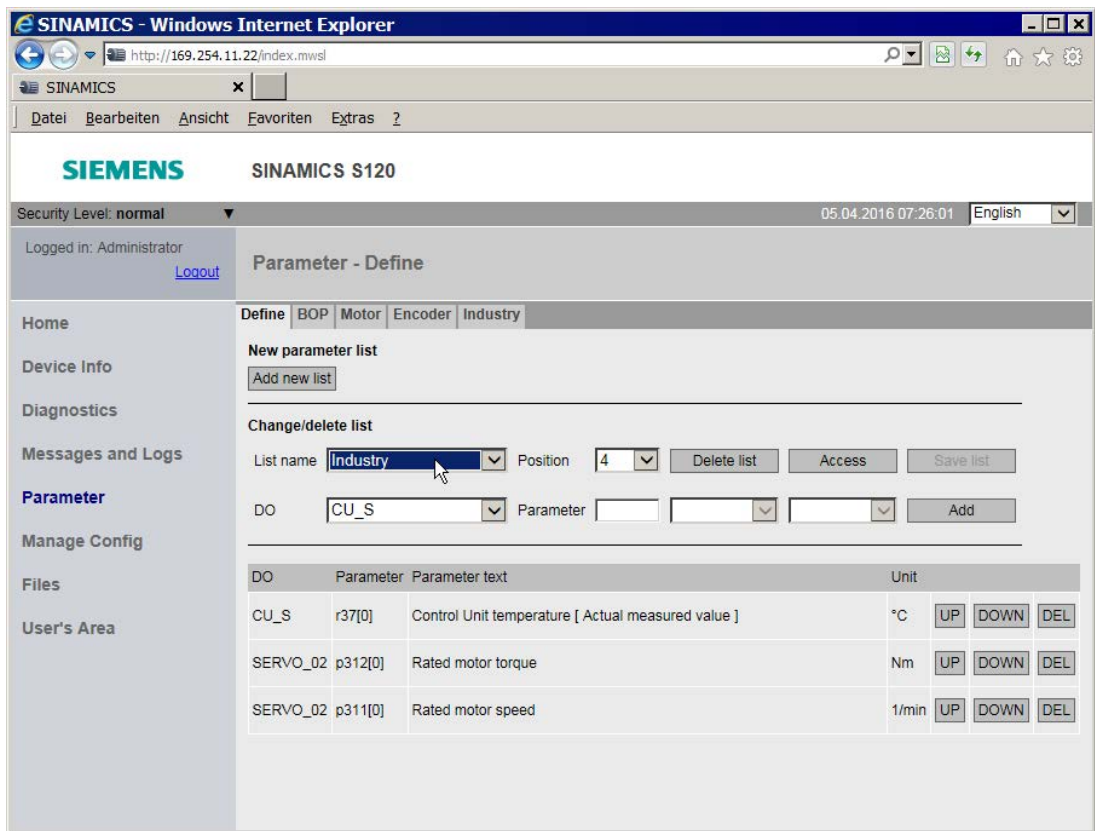

Figure 7-40 Drive parameters - deleting a parameter list

2. Click the "Delete list" button.

If you have the appropriate change rights, the displayed parameter list is now deleted.

Deleting entries from the parameter list

1. In the "List name" drop-down list, select the parameter list from which you want to delete selected list elements (lines).
2. Click the "DEL" button in the parameter list in front of the line that you want to delete.

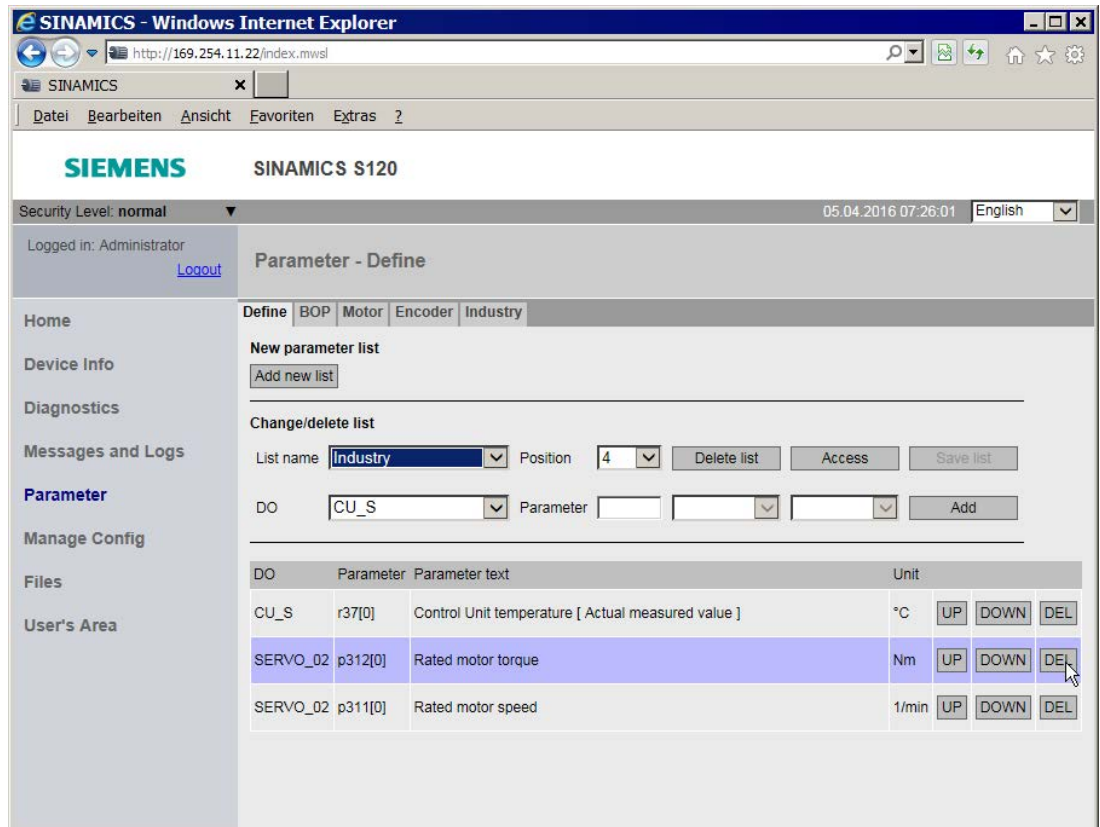

Figure 7-41 Drive parameters - deleting an individual list

If you have the required change rights for this parameter list, the line is deleted. You can delete further list elements in the same way. After deleting all the required list elements, the parameter list must be saved.

3. Click on the "Save list" button.

7.29.9.3 Displaying and changing drive parameters

The parameter values are displayed via the tab in the "Parameter" display area. Each list created is displayed as a separate tab.

The parameter display is updated regularly. If an update is not possible, the corresponding parameters are marked red.

To change the parameter values of a parameter list, then you require the corresponding write rights (see Chapter "Access rights for parameter lists (Page 409)"). In addition, the write and know-how protection apply.

Note

You can find detailed information about the following parameters in the SINAMICS S120/S150 List Manual in Section "Parameters for write protection and know-how protection":

- Parameters that can be changed with active know-how protection, see Section "Parameters with KHP_WRITE_NO_LOCK"
 - Parameters that can only be read with active know-how protection, see Section "Parameters with KHP_ACTIVE_READ"
-

Generally, only those parameter values in the parameter list can be changed for which you can see a "Change" button to the right of the line.

Requirement

- The required parameter list is created in the Web server.

Changing parameter values

1. Click the "Parameter" entry in the navigation.
2. Click the tab of the required parameter list in the "Parameter" display area.

The parameter list is displayed.

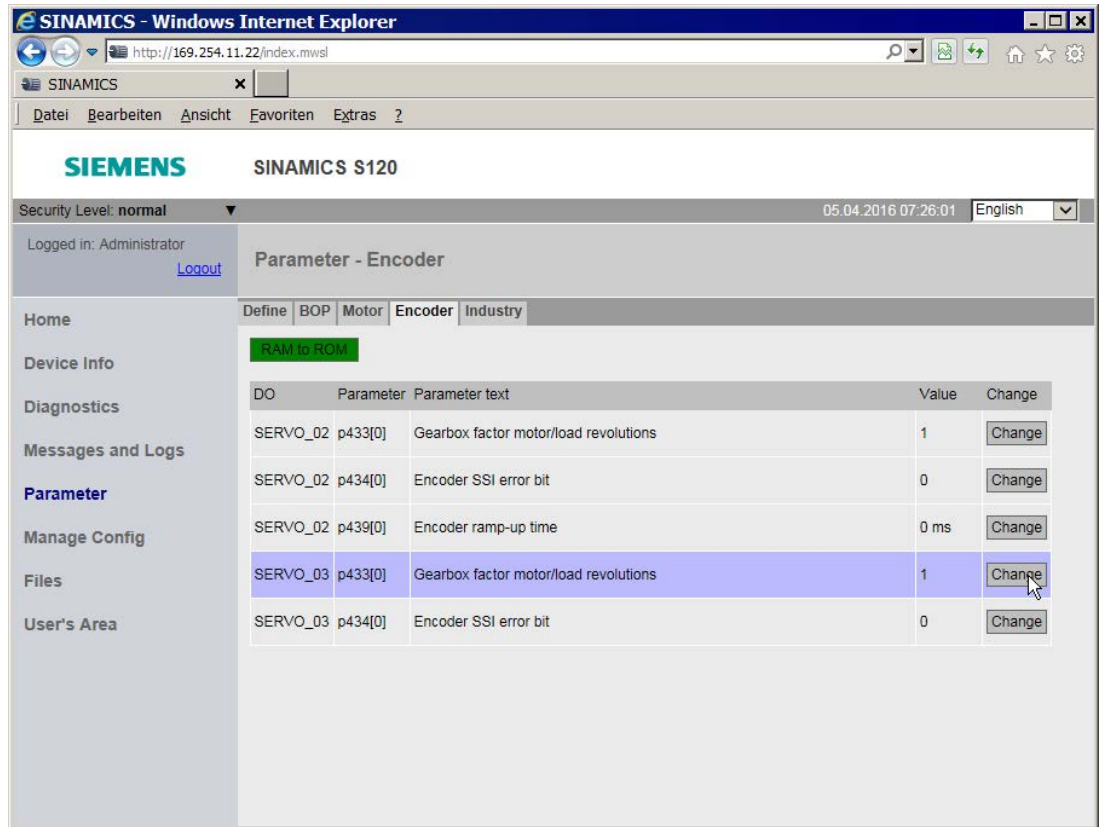

The screenshot shows the SINAMICS S120 web interface. The browser title is "SINAMICS - Windows Internet Explorer" and the address bar shows "http://169.254.11.22/index.mwsl". The page header includes the SIEMENS logo and "SINAMICS S120". The security level is "normal" and the user is logged in as "Administrator". The page title is "Parameter - Encoder". The navigation menu includes "Home", "Device Info", "Diagnostics", "Messages and Logs", "Parameter", "Manage Config", "Files", and "User's Area". The "Parameter" menu item is selected. The main content area shows a table of parameters for the Encoder. The table has columns for "DO", "Parameter", "Parameter text", "Value", and "Change". The parameters are listed as follows:

DO	Parameter	Parameter text	Value	Change
SERVO_02	p433[0]	Gearbox factor motor/load revolutions	1	Change
SERVO_02	p434[0]	Encoder SSI error bit	0	Change
SERVO_02	p439[0]	Encoder ramp-up time	0 ms	Change
SERVO_03	p433[0]	Gearbox factor motor/load revolutions	1	Change
SERVO_03	p434[0]	Encoder SSI error bit	0	Change

Figure 7-42 Changing drive parameters

3. Click in the line, next to the parameter whose value you wish to change, on the "Change" button.

A dialog box opens.

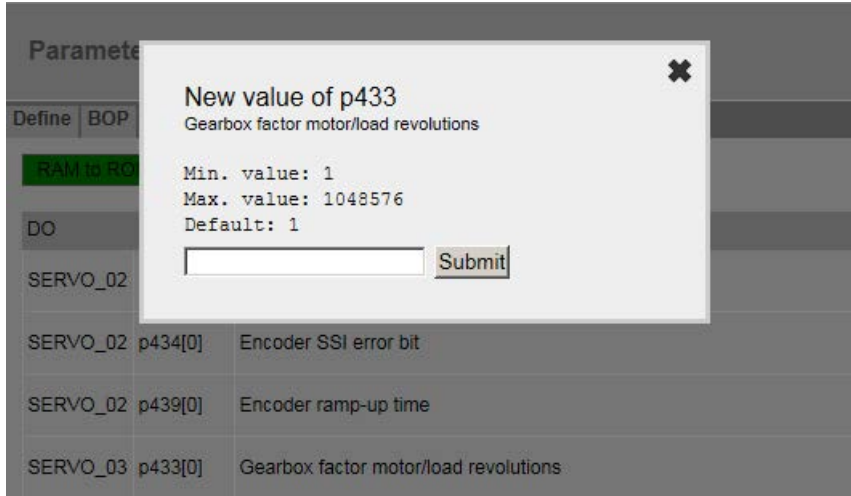

Figure 7-43 Changing drive parameters - new value

4. Enter the new parameter value in the "New value" input field. Then click "Confirm" to confirm the input.

If this value is not possible or not permitted, the dialog box remains open. A message text is also displayed.

When the entry of a parameter value is successful, the dialog box is closed. The new parameter value is displayed in the parameter list.

The changed parameter values must be saved to the memory card of the drive. After a parameter value has been changed, the "RAM to ROM" button is highlighted red.

5. Click on "RAM to ROM".

The RAM content is backed up with all changes made to the parameter values. The backup can take several seconds. The color of the button changes to green.

7.29.10 Updating the firmware or configuration

Series commissioning via the Web server

You can load a firmware or a configuration to the memory card of the drive with the aid of the Web server (see Updating firmware/configuration on the memory card (Page 387)).

One of the most important applications for the configuration update is the series commissioning via the duplication of a master configuration. The individual steps are listed in the following:

Sequence

1. Configure the master machine (STARTER offline and also online).
2. Switch STARTER offline.
3. Execute the "Load to file system" function in the STARTER.
Use the "Save compressed (.zip archive)" option.
4. Download the master configuration via the Web browser on the other drives (cloning).
5. If the know-how protection was not activated in the master configuration, you can now finely adjust the configuration for the individual drives.
If the know-how protection was activated, you require a password for the fine adjustment of all parameters on the individual drives that are not listed in the exception list.

Note

You can find detailed information about the following parameters in the SINAMICS S120/S150 List Manual in Section "Parameters for write protection and know-how protection":

- Parameters that can be changed with active know-how protection, see Section "Parameters with KHP_WRITE_NO_LOCK"
 - Parameters that can only be read with active know-how protection, see Section "Parameters with KHP_ACTIVE_READ"
-

6. Activate the know-how and copy protection for the individual drives, if required.

7.29.11 Certificates for the secure data transfer

7.29.11.1 Overview

The Secure Socket Layer protocol (SSL) enables encrypted data transfer between a client and the SINAMICS drive. HTTPS access between the browser and the drive is based on the Secure Socket Layer protocol.

This section informs you which steps you need to follow to enable encrypted data transfer between a client and SINAMICS.

Protecting the HTTPS access

The encrypted variant of the communication between the browser and the Web server using HTTPS requires the creation and installation of certificates.

You have three ways of creating a server certificate:

- Use the default configuration
- Use self-created certificates (by means of certificate software such as OpenSSL)
- Use a server certificate from a certificate authority

Key files

You need two key files for the encryption method used by the Secure Socket Layer protocol.

- A public certificate
- A private key

The pair of keys is created individually for the appropriate SINAMICS drive interface. This ensures that the address requested matches the SINAMICS drive reached during the HTTPS access.

Note

Encrypted access to the SINAMICS drive is only possible with the interface identifier (name or IP address) specified when the key was created.

The certificate handling then looks like this:

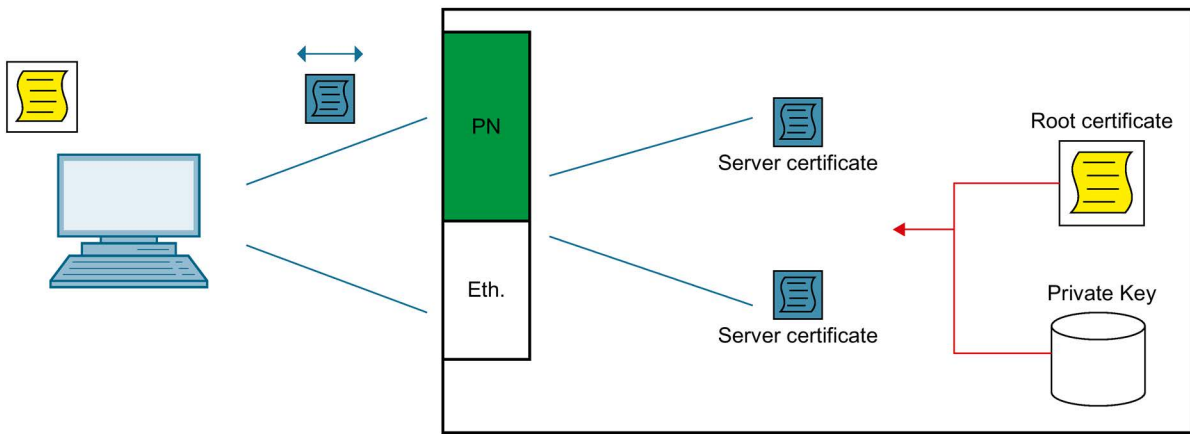

Figure 7-44 Certificate handling concept

You can find further information on Secure Socket Layer certificates at Address (<http://www.verisign.com>).

Delivery state

A private key is generated as a file on the device when you first use HTTPS so that you can access the drive via HTTPS in the SINAMICS delivery state.

During an HTTPS access using this key, a warning is issued in the browser that the certificate is unknown.

Validity period of the certificates

Certificates up to 2044 are valid.

After expiration of the validity period, new valid certificates must be installed on all the relevant drives.

7.29.11.2 Using the certificate default configuration

Note

Security

The use of a default configuration described in the following is not the most secure way of transferring data to your drive with the Web server.

It should therefore only be used if no self-created or purchased certificate can be used.

In the delivery state, there is a standard root certificate and a private key stored on the memory card of your device as a file.

Name of the root certificate ITDiagRootCA.crt

Name of the private key ITDiagRootCA.key

The server certificate and the private server key used later are automatically generated from this data.

Sequence

1. You first open an HTTPS Web server connection to your drive in the browser.
2. The firmware then creates a new server certificate and a private server key from the root certificate and the private key, if they are not already available. This is individualized for the IP address of the interface used for the communication.
3. Following this, a warning is issued in the browser that the certificate is unknown.
4. Import the server certificate in your standard browser.

Please follow the instructions (help) in your browser for the exact procedure when importing the certificate.

Alternatively, you can import the root certificate via the path "OEM/SINAMICS/HMICFG/CERT/ITDIAGROOTCA.CRT" instead of the server certificate. This root certificate can be used irrespective of the IP address and drive.

7.29.11.3 Generating your own certificates

You can either generate your own certificates for the secured data connection (the software required to do this is not included in the scope of delivery von SINAMICS S120) or purchase them from a certification authority. In these cases, a server certificate and a private server key are supplied.

Table 7- 17 Example:

Name of the server certificate	<IP-Addr>.SSL.crt (z. B. 192.168.2.90.SSL.crt)
Name of the private server key	<IP-Addr>.SSL.key (z. B. 192.168.2.90.SSL.key)

Sequence

1. Copy the server certificate (e.g. 192.168.2.90.SSL.crt) and the private server key (e.g. 192.168.2.90.SSL.key) to the memory card of your device (\\OEM\SINAMICS\HMICFG\CERT).
2. The used certificate must be loaded to the browser of your PC. It is recommended that you first assign a logical name to the certificate.
 - Make a backup copy of your certificate and rename the copy, e.g. as "SINAMICS.crt".
 - Import the copied certificate to your browser so that it is known in the PC.
Please follow the instructions (help) in your browser for the exact procedure when importing.
3. Open an HTTPS Web server connection to your drive in the browser.
 - If the certificate has been imported correctly, the required connection is established.
 - If the certificate was not imported, a message indicating that the signed CA is unknown is displayed when you open the browser.

7.29.12 Messages and parameters

Faults and alarms (see SINAMICS S120/S150 List Manual)

A09000 Web server security: Administrator password not set

Overview of important parameters (see SINAMICS S120/S150 List Manual)

- r0196[0...255] Topology component status
- r8911[0...3] IE IP Address of Station actual
- r8931[0...3] PN IP Address of Station actual
- p8986 Web server configuration
- p8987[0...1] Web server port assignment

Function modules

A function module is a functional expansion of a drive project that can be activated during commissioning.

Examples of function modules:

- Technology controller
- Setpoint channel
- Extended brake control

Function modules have their own parameters and, in some cases, also their own alarm and fault messages. These parameters and messages are only displayed when the function module is active. Please note when configuring, that an activated function module frequently requires additional computing time.

Certain function modules require a purchased license, without which the converter cannot be operated when the function module is selected.

Commissioning with STARTER

In the commissioning screens of STARTER, you can either directly or indirectly activate the function modules (e.g. technology controller). When the basic positioner (EPOS) is activated, for example, the position control is also automatically activated.

You can also activate function modules in STARTER under "Configuration" > "Function modules / technology packages". Function modules that are grayed-out in STARTER cannot be activated via STARTER.

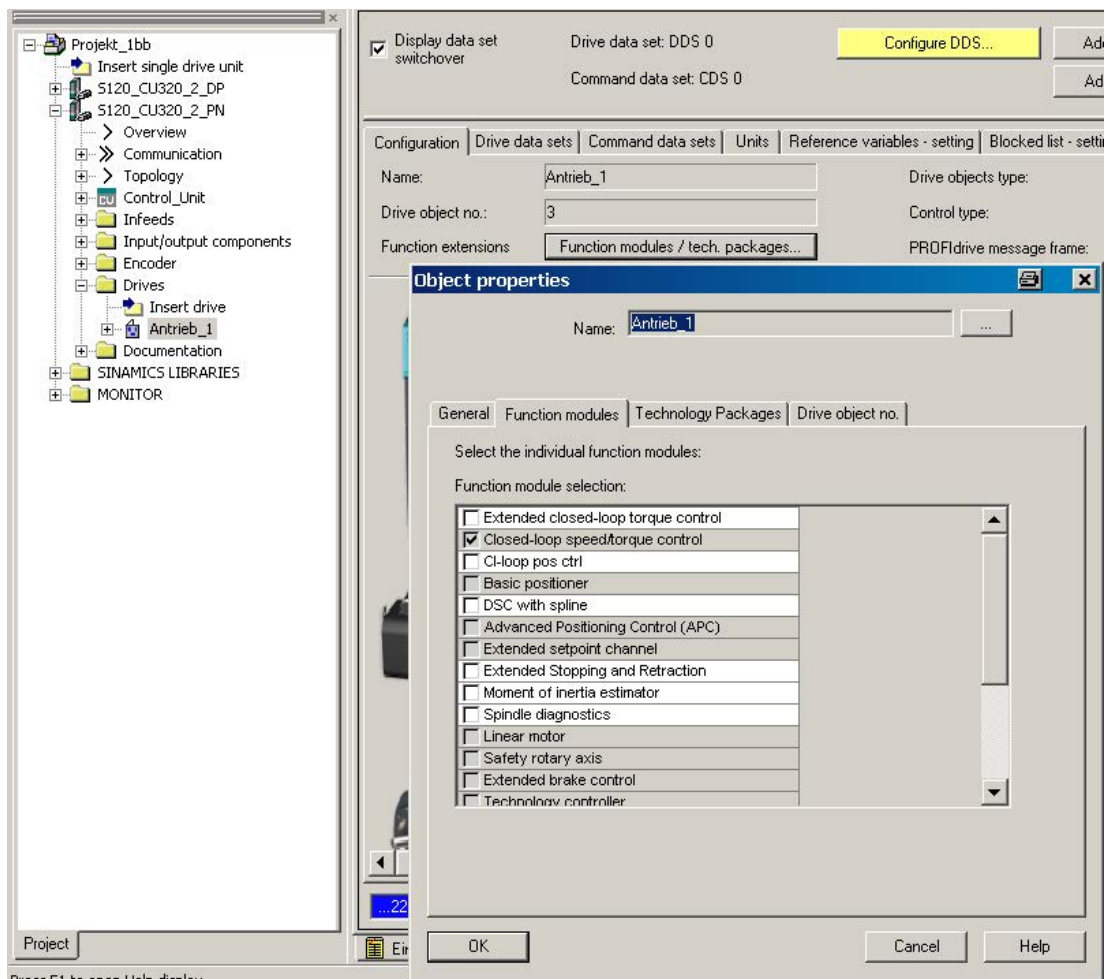

Commissioning via parameter (only with BOP20)

Function modules can be activated/deactivated using parameter p0108 of the Control Unit (CU).

Overview of important parameters (see SINAMICS S120/S150 List Manual)

- p0108[0..n] Drive object function module
- p0124[0...n] Main component identification via LED

8.1 Technology controller

Simple closed-loop control functions can be implemented with the technology controller, e.g.:

- Level control
- Temperature control
- Dancer roll position control
- Pressure control
- Flow control
- Simple closed-loop controls without higher-level controller
- Tension control

The technology controller features:

- Two scalable setpoints
- Scalable output signal
- Separate fixed values
- Integrated motorized potentiometer
- The output limits can be activated and deactivated via the ramp-function generator.
- The D component can be switched into the control deviation or actual value channel.
- The motorized potentiometer of the technology controller is only active when the drive pulses are enabled.

Description

The technology controller is designed as a PID controller, whereby the differentiator can be switched to the control deviation channel or the actual value channel (factory setting). The P, I, and D components can be set separately. A value of 0 deactivates the corresponding component. Setpoints can be specified via two connector inputs. The setpoints can be scaled via parameters (p2255 and p2256). A ramp-function generator in the setpoint channel can be used to set the setpoint ramp-up/ramp-down time via parameters p2257 and p2258. The setpoint and actual value channel each have a smoothing element. The smoothing time can be set via parameters p2261 and p2265.

The setpoints can be specified via separate fixed setpoints (p2201 to p2215), the motorized potentiometer, or via the fieldbus (e.g. PROFIBUS).

Precontrol can be integrated via a connector input.

The output can be scaled via parameter p2295 and the control direction reversed. It can be limited via parameters p2291 and p2292 and interconnected as required via a connector output (r2294).

The actual value can be integrated, for example, via an analog input on the TB30.

If a PID controller has to be used for control reasons, the D component is switched to the setpoint/actual value difference (p2263 = 1) unlike in the factory setting. This is always necessary when the D component is to be effective, even if the reference variable changes. The D component can only be activated when $p2274 > 0$.

Commissioning with STARTER

The "technology controller" function module can be activated via the commissioning wizard. You can check the actual configuration in parameter r0108.16.

Application example: Level control

The objective here is to maintain a constant level in the container.

This is carried out by means of a variable-speed pump in conjunction with a sensor for measuring the level.

The level is determined via an analog input (e.g. AI0 on TB30) and sent to the technology controller. The level setpoint is defined in a fixed setpoint. The resulting controlled variable is used as the setpoint for the speed controller.

In this example, a Terminal Board 30 (TB30) is used.

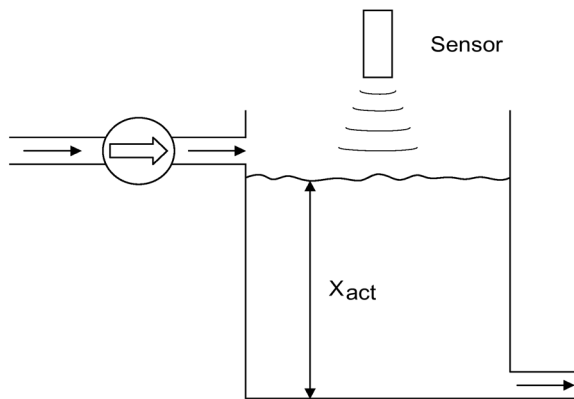

Figure 8-1 Level control: Application

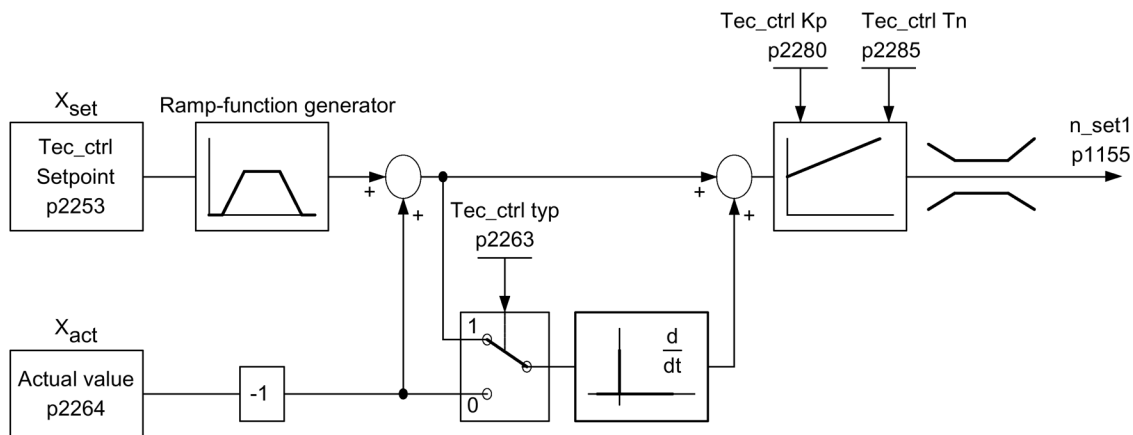

Figure 8-2 Level control: Controller structure

Table 8- 1 Important parameters for the level control

Parameter	Designation	Example
p1155	CI: Speed controller, speed setpoint 1	p1155 = r2294 Tec_ctrl output_sig [3080]
p2200	BI: Technology controller enable	p2200 = 1 Technology controller enabled
p2253	CI: Technology controller setpoint 1	p2253 = r2224 Fixed setpoint active [7950]
p2263	Technology controller type	p2263 = 1 D component in fault signal [7958]
p2264	CI: Technology controller actual value (X_{ACTUAL})	p2264 = r4055 [1] Analog input Ai1 of TB30
p2280	Technology controller p-gain	p2280 Determine by optimization
p2285	Technology controller integral time	p2285 Determine by optimization

Function diagrams (see SINAMICS S120/S150 List Manual)

- 7950 Technology controller - Fixed values, binary selection (r0108.16 = 1 and p2216 = 2)
- 7951 Technology controller - Fixed values, direct selection (r0108.16 = 1 and p2216 = 1)
- 7954 Technology controller - Motorized potentiometer (r0108.16 = 1)
- 7958 Technology controller - Closed-loop control (r0108.16 = 1)
- 7960 Technology controller - Controller DC link voltage (r0108.16 = 1)

Overview of important parameters (see SINAMICS S120/S150 List Manual)

Fixed setpoints

- p2201[0...n] CO: Technology controller fixed value 1
- ...
- p2215[0...n] CO: Technology controller fixed value 15
- p2220[0...n] BI: Technology controller fixed value selection bit 0
- p2221[0...n] BI: Technology controller fixed value selection bit 1
- p2222[0...n] BI: Technology controller fixed value selection bit 2
- p2223[0...n] BI: Technology controller fixed value selection bit 3

Motorized potentiometer

- p2230[0...n] Technology controller motorized potentiometer configuration
- r2231 Technology controller motorized potentiometer setpoint memory
- p2235[0...n] BI: Technology controller motorized potentiometer, setpoint, raise
- p2236[0...n] BI: Technology controller motorized potentiometer, setpoint, lower
- p2237[0...n] Technology controller motorized potentiometer maximum value
- p2238[0...n] Technology controller motorized potentiometer minimum value
- p2240[0...n] Technology controller motorized potentiometer start value
- r2245 CO: Technology controller motorized potentiometer, setpoint before RFG
- p2247[0...n] Technology controller motorized potentiometer ramp-up time
- p2248[0...n] Technology controller motorized potentiometer ramp-down time
- r2250 CO: Technology controller motorized potentiometer, setpoint after RFG

Closed-loop control

- p2200[0...n] BI: Technology controller enable
- p2253[0...n] CI: Technology controller setpoint 1
- p2254 [0...n] CI: Technology controller setpoint 2
- p2255 Technology controller setpoint 1 scaling
- p2256 Technology controller setpoint 2 scaling
- p2257 Technology controller ramp-up time
- p2258 Technology controller ramp-down time
- r2260 CO: Technology controller setpoint after ramp-function generator
- p2261 Technology controller setpoint filter time constant
- r2262 CO: Technology controller setpoint after filter
- p2263 Technology controller type
- p2264[0...n] CI: Technology controller actual value

- p2265 Technology controller actual value filter time constant
- r2266 CO: Technology controller actual value after filter
- p2267 Technology controller upper limit actual value
- p2268 Technology controller lower limit actual value
- p2269 Technology controller gain actual value
- p2270 Technology controller actual value function
- p2271 Technology controller actual value inversion (sensor type)
- r2272 CO: Technology controller actual value scaled
- r2273 CO: Technology closed-loop controller
- p2274 Technology controller differentiation time constant
- p2280 Technology controller proportional gain
- p2285 Technology controller integral time
- p2286[0...n] BI: Hold technology controller integrator
- p2289[0...n] CI: Technology controller precontrol signal
- p2291 CO: Technology controller maximum limiting
- p2292 CO: Technology controller minimum limiting
- p2293 Technology controller ramp-up/ramp-down time
- r2294 CO: Technology controller output signal
- p2295 CO: Technology controller output scaling
- p2296[0...n] CI: Technology controller output scaling
- p2297[0...n] CI: Technology controller maximum limiting signal source
- p2298[0...n] CI: Technology controller minimum limiting signal source
- p2299[0...n] CI: Technology controller limitation offset

8.2 Extended monitoring functions

When the extension is activated, the monitoring functions are extended as follows:

- Speed setpoint monitoring: $|n_set| \leq p2161$
- Speed setpoint monitoring: $n_set > 0$
- Load monitoring

Load monitoring

This function monitors power transmission between the motor and the working machine. Typical applications include V-belts, flat belts, or chains that loop around the belt pulleys or cog wheels for drive and outgoing shafts and transfer the peripheral speeds and forces. The load monitoring can identify blockages in the working machine and interruptions to the power transmission.

During load monitoring, the current speed/torque curve is compared with the programmed speed/torque curve (p2182 to p2190). If the actual value is outside the programmed tolerance bandwidth, a fault or alarm is triggered depending on parameter p2181. Faults or alarms can be delayed using parameter p2192 to prevent false messages caused by brief transitional states.

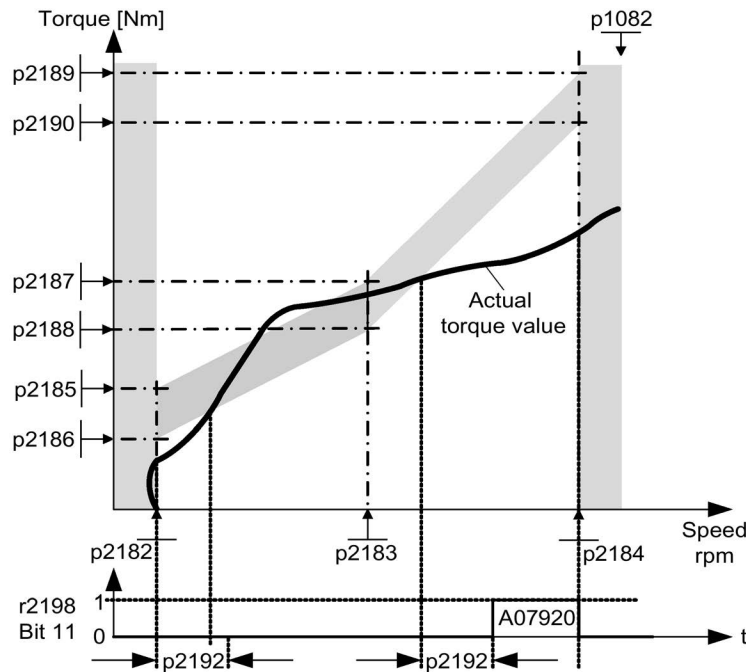

Figure 8-3 Load monitoring

Commissioning

This function module can be activated via the commissioning wizard.

You can check the current configuration in parameter r0108.17.

Function diagrams (see SINAMICS S120/S150 List Manual)

- 8010 Signals and monitoring functions - Speed messages 1
- 8011 Signals and monitoring functions - Speed messages 2
- 8013 Signals and monitoring functions - Load monitoring (r0108.17 = 1)

Overview of important parameters (see SINAMICS S120/S150 List Manual)

Load monitoring

- p2181[0...n] Load monitoring, response
- p2182[0...n] Load monitoring, speed threshold 1
- p2183[0...n] Load monitoring, speed threshold 2
- p2184[0...n] Load monitoring, speed threshold 3
- p2185[0...n] Load monitoring, torque threshold 1, upper
- ...
- p2190[0...n] Load monitoring torque threshold 3, lower
- p2192[0...n] Load monitoring, delay time

Speed setpoint monitoring

- p2150[0...n] Hysteresis speed 3
- p2151[0...n] CI: Speed setpoint for messages
- p2161[0...n] Speed threshold 3
- r2198.4 CO/BO: Status word, monitoring 2;
|n_set| ≤ p2161
- r2198.5 CO/BO: Status word, monitoring 2;
n_set < 0

8.3 Extended Brake Control

Features

- Forced brake release (p0855, p1215)
- Closing of brake for a 1 signal "unconditionally close holding brake" (p0858)
- Binector inputs for opening or closing the brake (p1218, p1219)
- Connector input for threshold value for opening and closing the brake (p1220)
- OR/AND block, each with two inputs (p1279, r1229.10, r1229.11)
- Holding and operational brakes can be activated
- Function for monitoring brake feedback signals (r1229.4, r1229.5)
- Configurable responses (A07931, A07932)
- Closing of brake after "Enable speed controller" signal has been canceled (p0856)

Brake control options

The "Extended brake control" function allows complex braking control, e.g. for motor holding brakes and operational brakes.

The brake is controlled in the following way. The order shows the prioritization:

- Using parameter p1215
- Via binectors p1219[0...3] and p0855
- Using zero speed detection
- Via the connector interconnection, threshold value

For an AC drive with "Safe Brake Relay," the "Safe Brake Control" safety function requires that the type of the brake control be set in parameter p1278, to "Brake control with diagnostic evaluation" (p1278 = 0). This parameter is automatically set for booksize components.

Commissioning

1. Activate the "Extended brake" function module using the commissioning Wizards.

You can check that it has been activated in parameter r0108.14.

Brake control will be activated automatically (p1215 = 1) when the Motor Module has an internal brake control and a connected brake has been found.

2. If there is no internal brake control, activate the control using p1215 = 3.

Unless you change the default settings, the extended brake control function behaves in exactly the same way as the simple brake control function.

3. In the case of brakes with a feedback signal (p1222), interconnect the inverted signal to the BICO input for the 2nd feedback signal (p1223). You set the switching times of the brake in p1216 and p1217.

 **WARNING**

Danger as a result of a damaged holding brake caused by incorrect parameterization

If the drive moves against the closed holding brake, this can destroy the holding brake and as a consequence result in death or severe injury.

- If a holding brake is being used, do **not** set p1215 = 0.
- Correctly set all of the parameters involved.

Note

It is only permissible to activate brake control monitoring for power units of the "booksize" and "blocksize with Safe Brake Relay" format (p1278 = 0).

Extended brake control for braking with feedback

For braking with feedback (p1275.5 = 1), the brake control reacts to the feedback signal contacts of the brake. If the timer p1216 is greater than the time to the feedback signal, the startup is delayed to the corresponding time difference.

In order to start up as far as possible without any delay, the set timer p1216 must be less than the time to the feedback signal. If the timer is set lower however, alarm "A07931, brake does not open" appears.

Remedy:

1. Activate "Release with feedback signal" (p1275.6 = 1).

The pulse enable (BO: r1229.3) and setpoint enable (BO: r0899.15) are now independent of the set time level (p1217, p1216). The associated enable is determined only by the feedback signal (BI: p1222, BI: p1223). The timers (p1216, p1217) only influence the alarms A07931 "Brake does not open" and A07932 "Brake does not close".

2. Optional: In order that the alarms no longer appear, set the two timers (p1217, p1216) to 0 ms.

Result: The monitoring of the brake and the display of the alarms are switched off.

Note

Speed controller response when a brake is opened

Information on the speed controller response for vector control is provided in Chapter Speed controller (Page 203).

Examples

Starting against a closed brake

When the device is switched on, the setpoint is enabled immediately (if the required enable signals are issued), even if the brake has not yet been released ($p1152 = 1$). The factory setting $p1152 = r0899.15$ must be separated here. The drive starts to generate torque against the closed brake. The brake is not opened until the motor torque or current ($p1220$) has exceeded braking threshold 1 ($p1221$). Depending on the type and design of the brake, the time required to completely open the brake differs. Note that once the braking threshold torque has been exceeded, the operation enabling signal ($p0899.2$) is interrupted while the brake is being opened ($p1216$) to ensure that the motor current does not exceed the permissible limit values during this period and/or the motor torque generated does not damage the brake. Interval $p1216$ must be set on the basis of the time the brake actually requires to release.

Emergency brake

In the case of emergency braking, electrical and mechanical braking should be realized at precisely the same time. This can be achieved by using OFF3 as a tripping signal for emergency braking:

$p1219[0] = r0898.2$ and $p1275.00 = 1$ (OFF3 to "Close brake immediately" and invert signal).

To ensure that the frequency converter does not operate against the brake, the OFF3 ramp ($p1135$) should be set to 0 seconds. Regenerative energy can be generated, which must be either fed back to the line supply or dissipated by means of a braking resistor.

Service brake on crane drives

For cranes with manual control, it is important that the drive responds immediately when the control lever is moved (master switch). The drive is switched on with an ON command ($p0840$) (the pulses are enabled). Speed setpoint ($p1142$) and speed controller ($p0856$) are inhibited. The motor is magnetized. The magnetization time required for three-phase motors (1-2 s), therefore, no longer applies.

Now, only the brake opening time will delay the motor starting to rotate following activation of the master switch. If the master switch is moved (deflected), then there is a "setpoint enable from the control" (bit interconnected with $p1142$, $r1229.3$, $p1224.0$). The speed controller is enabled immediately. Once the brake opening time has elapsed ($p1216$), the speed setpoint is enabled. When the master switch is in the zero position, the speed setpoint is inhibited and the drive brakes along the deceleration ramp of the ramp-function generator. The brake closes when the speed drops below the standstill limit ($p1226$). After the brake closing time ($p1217$), the speed controller is inhibited (no motor force!). The extended brake control is used.

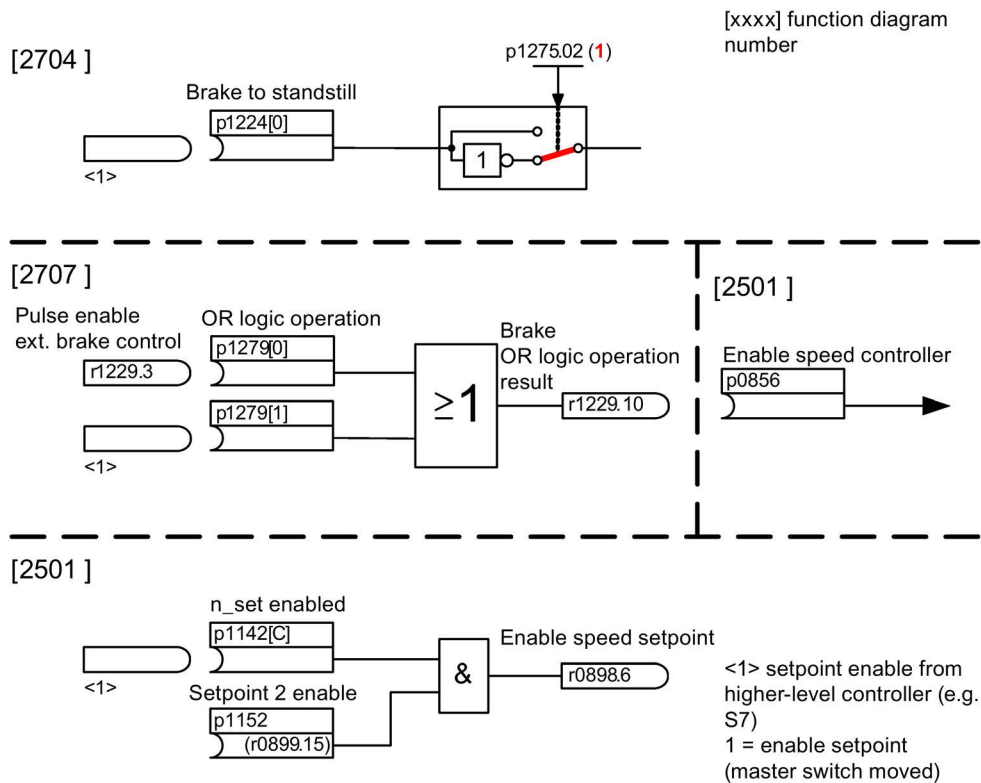

Figure 8-4 Example of operating brake for a crane drive

Control and status messages for extended brake control

Table 8-2 Controller extended brake control

Signal name	Binector input	Control word sequence control / inter-connection parameters
Enable speed setpoint	p1142 BI: Enable speed setpoint	STWA.6
Enable setpoint 2	p1152 BI: Setpoint 2 enable	p1152 = r0899.15
Unconditionally open holding brake	p0855 BI: Unconditionally open holding brake	STWA.7
Enable speed controller	p0856 BI: Enable speed controller	STWA.12
Unconditionally close holding brake	p0858 BI: Unconditionally close holding brake	STWA.14

Table 8- 3 Status message of extended brake control

Signal name	Parameter	Brake status word
Command, open brake (continuous signal)	r1229.1	B_ZSW.1
Pulse enable, extended brake control	r1229.3	B_ZSW.3
Brake does not open	r1229.4	B_ZSW.4
Brake does not close	r1229.5	B_ZSW.5
Brake threshold exceeded	r1229.6	B_ZSW.6
Value below brake threshold	r1229.7	B_ZSW.7
Brake monitoring time expired	r1229.8	B_ZSW.8
Request, pulse enable missing/n_ctrl inhibited	r1229.9	B_ZSW.9
Brake OR logic operation result	r1229.10	B_ZSW.10
Brake AND logic operation result	r1229.11	B_ZSW.11

Function diagrams (see SINAMICS S120/S150 List Manual)

- 2704 Brake control - Extended brake control, standstill detection (r0108.14 = 1)
- 2707 Brake control - Extended brake control / open/close brake (r0108.14 = 1)
- 2711 Brake control - Extended brake control, signal outputs (r0108.14 = 1)

Overview of important parameters (see SINAMICS S120/S150 List Manual)

- r0108.14 Drive objects, function module;
Extended brake control
- r0899.0...15 CO/BO: Status word, sequence control

Standstill monitoring

- r0060 CO: Speed setpoint before the setpoint filter
- r0063 CO: Speed actual value smoothed (for servo)
- r0063[0...2] CO: Actual speed value (for vector)
- p1224[0...3] BI: Close motor holding brake at standstill
- p1225 CI: Standstill detection threshold value
- p1226[0...n] Standstill monitoring speed threshold
- p1227 Standstill detection monitoring time
- p1228 Pulse suppression delay time
- p1276 Motor holding brake standstill detection bypass

Open and close the brake

- p0855[0...n] BI: Unconditionally open holding brake
- p0858[0...n] BI: Unconditionally close holding brake
- p1216 Motor holding brake opening time
- p1217 Motor holding brake closing time
- p1218[0...1] BI: Open motor holding brake
- p1219[0...3] BI: Immediately close motor holding brake
- p1220 CI: Open motor holding brake, signal source, threshold
- p1221 Open motor holding brake, threshold
- p1277 Motor holding brake, delay, braking threshold exceeded
- p1279[0...3] BI: Motor holding brake, OR/AND logic operation

Free blocks

- p1279[0...3] BI: Motor holding brake, OR/AND logic operation

Brake monitoring functions

- p1222 BI: Motor holding brake, feedback signal, brake closed
- p1223 BI: Motor holding brake, feedback signal, brake open

Configuration, control/status words

- p1215 Motor holding brake configuration
- r1229.1...11 CO/BO: Motor holding brake status word
- p1275 Motor holding brake control word
- p1276 Motor holding brake standstill detection bypass
- p1278 Brake control diagnostics evaluation

8.4 Braking Module External

This function module can be activated via the infeed commissioning wizard.

You can check the current configuration in parameter r0108.26.

The appropriate binectors must be interconnected via digital inputs/outputs (e.g. Control Unit, TM31 or TB30) with the Braking Module.

In order to obtain the maximum power of a Braking Module, the Vdc_max control must be disabled.

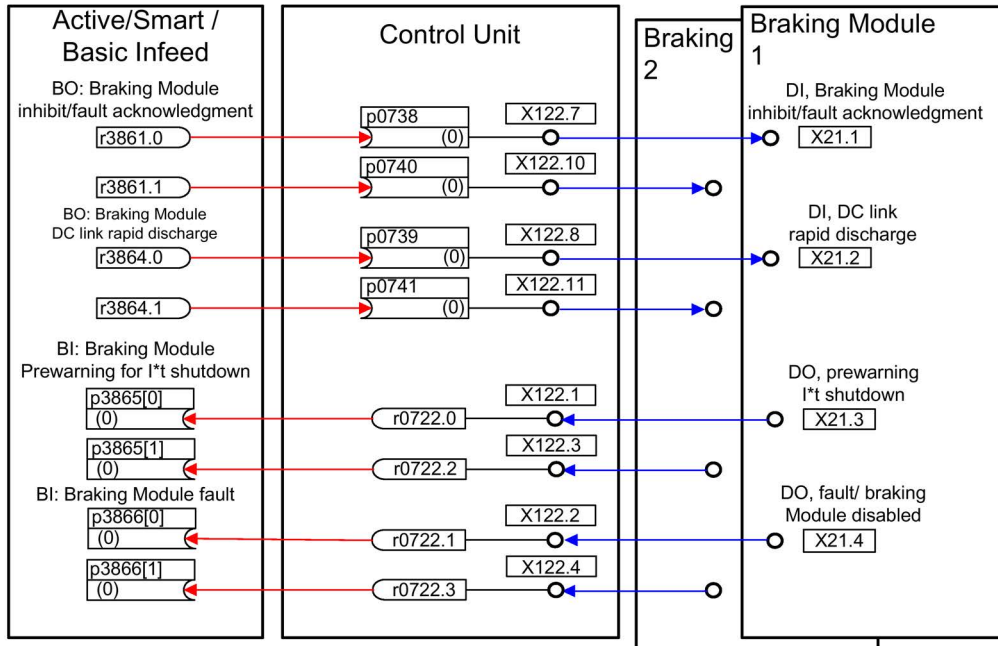

Figure 8-5 Example of controlling two booksize Braking Modules

Features

- Braking the motor without any possibility of regenerating into the line supply (e.g. power failure)
- Fast DC link discharge (booksize format)
- The Braking Module External terminals are controlled via the drive object infeed (booksize and chassis format)
- Controlling up to eight Braking Modules in a parallel connection
- Acknowledging faults at the Braking Module External

Acknowledgment of faults

When the Braking Module issues a fault message at binector input p3866, an attempt is made to acknowledge the fault using signal r3861 at terminal X21.1 booksize or X21.3 chassis every 10 ms. Alarm A06900 is output simultaneously.

Parameterization

Table 8- 4 Parameterization

Sink			Source		
Parameter	Description	DO	Parameter	Description	DO
p1240	Vdc controller or Vdc monitoring configuration	Vector	0	Inhibit Vdc controller	
p2108	Ext. fault_3	Vector	r0722.4	DI 4 (X132.1)	CU
p3111	BI: External fault 3 enable	Vector	r0899.2	Operation enabled	Vector
p0745	BI: CU signal source for terminal DI/DO 15 (X132.13 / X131.5)	CU	r2138.7	Acknowledge fault	Vector

Fast DC link discharge (booksize)

It is only possible to quickly discharge the DC link via the Braking Module External for the booksize format. It is activated via binector input p3863 and started after the line contactor opens and the adjustable delay time (p3862) has expired. The fast discharge is completed when the line contactor contact closes.

Note

A fast DC link discharge requires the use of a line contactor with feedback signal (p0860) that is controlled via r0863.1.

Overview of important parameters (see SINAMICS S120/S150 List Manual)

- r0108.26 Drive object function module; Braking Module External
- p3860 Braking Module number of modules connected in parallel
- r3861.0...7 BO: Braking Module inhibit/acknowledgment
- p3862 Braking module, DC link fast discharge delay time
- p3863 BI: Braking Module, activate DC link fast discharge
- p3864.0...7 BO: Braking Module DC link fast discharge
- p3865[0...7] BI: Braking Module pre-alarm I*t shutdown
- p3866[0...7] BI: Braking Module fault

8.5 Cooling unit

A cooling unit (RKA) is responsible for the cooling and the (non) conductivity in the de-ionized water cooling circuit of a liquid-cooled power unit. The cooling unit is controlled and monitored from a PLC that is part of the cooling unit.

The "cooling unit" function module described here is used as an interface between the Control Unit and the external PLC as well as external sensors of the cooling unit. Signals for control and messages between the PLC and the Control Unit can be exchanged via this interface. The PLC communicates with the Control Unit via terminals and/or via a fieldbus (e.g. PROFIBUS or PROFINET).

Features

- Automatically activated when using liquid-cooled power units
- Evaluation of an external sensor for leakage water
- Evaluation of an external sensor for liquid flow
- Evaluation of an external sensor for conductivity
- Monitoring the liquid intake temperature using external temperature sensors
- Monitoring the flow rating using internal temperature sensors
- Evaluation of signals transmitted from the PLC of the cooling unit
- Acknowledging cooling unit faults

Commissioning

You activate the "cooling unit" function module while configuring the associated power unit (a power unit is a Motor Module or an Infeed Module):

1. When selecting the power unit, set the cooling type to "Liquid cooling".
2. Complete the configuration.
3. After configuration has been completed, the heat exchanger unit can be seen in the navigation window under "Power Unit > Functions" (also in the shortcut menu of the power unit under "Functions").
4. Double-clicking "Cooling unit" opens the window for setting the monitoring functions. In this window, BICO interconnections can be set for communication with the controller of the cooling unit and the cooling water circuit monitoring.

You can check the current configuration in parameter r0108.28.

Function diagrams (see SINAMICS S120/S150 List Manual)

- 9794 Auxiliaries - Cooling unit, control and feedback signals (r0108.28 = 1)
- 9795 Auxiliaries - Cooling unit, sequence control (r0108.28 = 1)

Overview of important parameters (see SINAMICS S120/S150 List Manual)

- r0046.29 CO/BO: Missing enables;
cooling unit ready missing
- r0108.28 Drive object function module;
cooling unit
- p0192.06 Power unit firmware properties;
liquid cooling
- r0204.06 Power unit hardware properties 1;
liquid cooling with cooling unit (chassis power unit)
- p0260 Cooling unit startup time 1
- p0261 Cooling unit startup time 2
- p0262 Cooling unit fault conductivity delay time
- p0263 Cooling unit fault liquid flow delay time
- p0264 Cooling unit delay time
- r0265.0...3 BO: Cooling unit control word
- p0266[0...7] BI: Cooling unit feedback signals signal source
- r0267.0...7 BO: Cooling unit status word

8.6 Extended torque control (k_T estimator, servo)

The "extended torque control" function module comprises two modules - the k_T estimator and the compensation of the voltage emulation error of the drive converter. As a consequence, the torque accuracy is increased.

Note

When this function module is activated, the maximum number of drives that can be controlled from a Control Unit is reduced by at least one drive.

Features

- k_T estimator (only for synchronous motors)
- Compensation of the voltage emulation error of the drive converter (p1952, p1953)
- Configuration via p1780

Commissioning

The extended torque control is activated offline:

1. Click the drive and right-click to open the shortcut menu "Properties ... ".
The "Object Properties" window opens.
2. Click the "Function modules" tab.
The selection of possible function modules opens.
3. Click the "Extended torque control" checkbox to activate this option.
4. Click "OK" to activate the function module.
5. Select the "Connect to selected target devices" option.
6. Call the "Download project to target system" function.

Alternatively, you can also activate function modules in STARTER under "Configuration > Function modules / technology packages".

Activation can be checked in parameter r0108.1.

Description of the k_T estimator

The adaptation of the torque constants for synchronous motors is used to improve the absolute torque accuracy for the control (closed-loop) of synchronous motors. The magnetization of the permanent magnets varies as a result of production tolerances and temperature fluctuations and saturation effects. The function " k_T estimator" adapts the torque constant k_T [Nm/A] in the control to the prevailing magnetization. It only makes sense to use the k_T estimator in conjunction with the friction characteristic as the k_T estimator corrects the inner motor torque. The frictional losses must be compensated from the friction characteristic using a supplementary torque.

The k_T estimator requires the most accurate values for the motor parameters as possible in order to achieve a high torque accuracy. Before using the k_T estimator, a motor data

identification (p1909, p1910) must be performed with activated $k_{restimator}$. In this procedure, the values for stator resistance (p0350), leakage inductance (p0356) and voltage emulation errors (p1952, p1953) are determined. The cable resistance must be entered in p0352 before motor data identification.

The motor should be at room temperature when the identification routine is carried out. Compensation of the voltage emulation error must be activated (p1780.8 = 1). The motor temperature (p0600) should be sensed using a KTY or PT1000 sensor (p0601 = 2 or 3).

The k_T estimator requires the motor temperature in order to track/correct the temperature-dependent quantities. The estimate is less accurate if a motor temperature sensor is not connected.

The k_T estimator is only activated above a specific speed (p1752). The terminal voltage of the converter always has small inaccuracies. The lower the output voltage and speed, the more inaccurate the estimate. This is the reason why the estimation is deactivated below a specific speed. The estimated value is smoothed using time constant p1795. The correction value for the torque constant is displayed in r1797.

By identifying the torque constant k_T using the rotating motor data identification routine, the torque accuracy can be improved also below the speed threshold (p1752).

The k_T estimator is activated using p1780.3 and the voltage compensation using p1780.8.

Function diagrams (see SINAMICS S120/S150 List Manual)

- 7008 Technology functions - k_T estimator

Overview of important parameters (see SINAMICS S120/S150 List Manual)

- r0108.1 Drive object function module; extended torque control
- p1780.3 Motor model adaptation configuration; selects motor model PMSM k_T adaptation
- p1780.8 Motor model adaptation configuration; compensation of the voltage emulation error in the drive converter

Motor/drive converter identification

- p0352[0...n] Cable resistance
- p1909[0...n] Motor data identification, control word
- p1910 Motor data identification, stationary

k_T estimator

- p1752[0...n] Motor model, changeover speed operation with encoder
- p1795[0...n] Motor model k_T adaptation smoothing time
- r1797[0...n] Motor model k_T adaptation correction value

Compensation of the voltage emulation error of the drive converter

- p1952[0...n] Voltage emulation error, final value
- p1953[0...n] Voltage emulation error, current offset

8.7 Position control

8.7.1 General features

The position controller essentially comprises the following parts:

- Position actual value conditioning (including the lower-level measuring probe evaluation and reference mark search)
- Position controller (including limits, adaptation and the pre-control calculation)
- Monitoring functions (including standstill, positioning, dynamic following error monitoring and cam signals)
- Position tracking of the load gear (motor encoder), using absolute encoders for rotary axes (modulo) as for linear axes.

8.7.2 Position actual value conditioning

8.7.2.1 Features

- Correction value (p2512, p2513)
- Setting value (p2514, p2515)
- Position offset (p2516)
- Position actual value (r2521)
- Velocity actual value (r2522)
- Motor revolutions (p2504)
- Load revolutions (p2505)
- Spindle pitch (p2506)
- Position tracking (p2720ff)

8.7.2.2 Description

The actual position value processing converts the actual position value into a neutral distance unit LU (Length Unit). To do this, the function block uses the encoder evaluation / motor control with the available encoder interfaces Gn_XIST1, Gn_XIST2, Gn_STW and Gn_ZSW. These just provide position information in encoder pulses and fine resolution (increments).

The actual position value is conditioned, regardless of whether the position controller is enabled immediately after the system has booted, as soon as valid values are received via the encoder interface.

Parameter p2502 (encoder assignment) is used to define from which encoder (1, 2 or 3), the actual position value is sensed.

The following interconnections are automatically established after the assignment has been made.

- p0480[0] (G1_STW) = encoder control word r2520[0]
- p0480[1] (G2_STW) = encoder control word r2520[1]
- p0480[2] (G3_STW) = encoder control word r2520[2]

p2502 = 1, position control on motor encoder 1

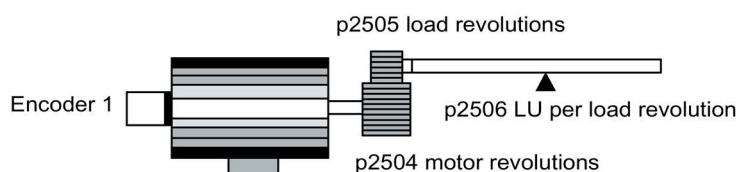

p2502 = 2, position control on external encoder 2

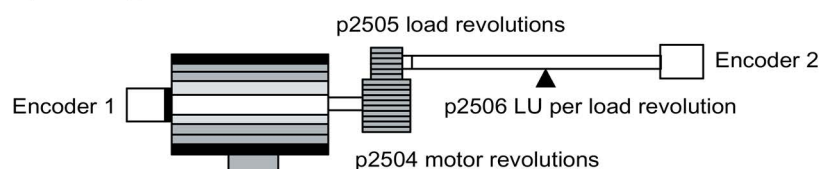

Figure 8-6 Actual position value sensing with rotary encoders

The link between the physical variables and the neutral length unit LU is established via parameter p2506 (LU per load revolution) for rotary encoders. Parameter p2506 mirrors, together with p2504, p2505, the interrelationship between encoder increments and the neutral length unit LU.

Example:

Rotary encoder, ball screw with a pitch of 10 mm/revolution. 10 mm should have a resolution of 1 μm (i.e. 1 LU = 1 μm).

-> One load revolution corresponds to 10000 LU

-> p2506 = 10000

Note

The effective actual value resolution is obtained from the product of the encoder pulses (p0408) and the fine resolution (p0418) and a measuring gear that is possibly being used (p0402, p0432, p0433).

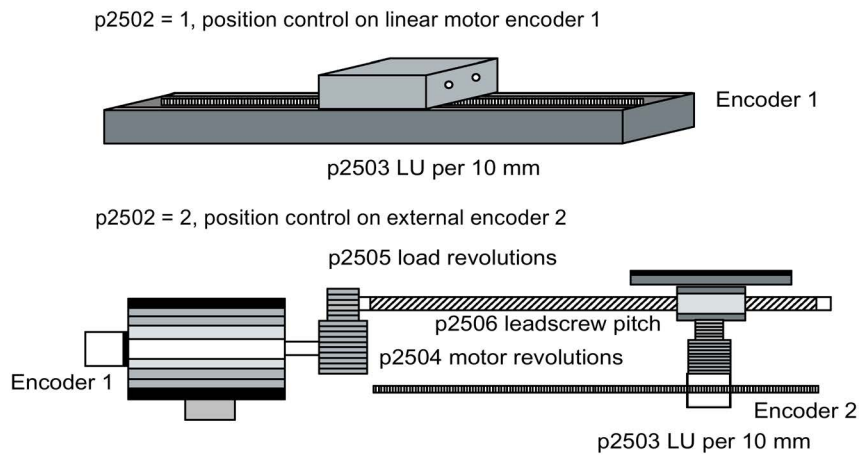

Figure 8-7 Actual position value sensing with linear encoders

For linear encoders, the interrelationship between the physical quantity and the neutral length unit LU is configured using parameter p2503 (LU/10 mm).

Example:

Linear encoder, 10 mm should have a resolution of 1 μm (i.e. 1 LU = 1 μm).

-> p2503 = 10000

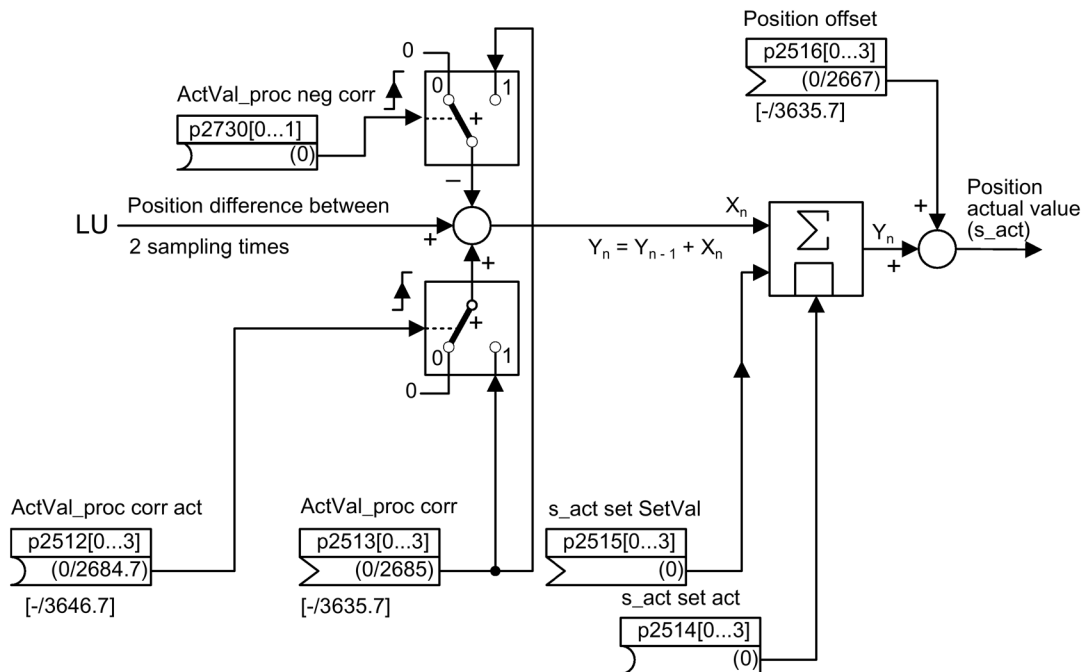

Figure 8-8 Actual position value processing

A correction can be made using connector input p2513 (correction value, actual position value processing) and a positive edge at binector input p2512 (activates the correction value). When the "basic positioning" function module is activated, p2513 is automatically

interconnected with r2685 (EPOS correction value) and p2512 with r2684.7 (activate correction). This interconnection enables modulo offset by EPOS, for example.

The correction value present at the connector input p2513 can be negated and activated via p2730.

p2516 can be used to switch in position offset. Using EPOS, p2516 is automatically interconnected to r2667. Backlash compensation is implemented using this interconnection.

Using the connector input p2515 (position setting value) and a "1" signal at binector input p2514 (set actual position value), a position setting value can be entered.

Note**No evaluation of the incoming encoder increments**

When the actual position value is set (p2514 = "1" signal), the actual position value of the position controller is kept at the value of connector p2515 as standard.

Incoming encoder increments are not evaluated. A difference in position cannot be compensated for in this situation.

An inversion of the actual position value resulting from the encoder is undertaken using parameter p0410. An inversion of the axis motion can be entered using a negative value in p2505.

8.7.2.3 Indexed actual value acquisition

The indexed actual position value acquisition permits, e.g. length measurements on parts as well as the detection of axis positions by a higher-level controller (e.g. SIMATIC S7) in addition to the position control, e.g. of a belt conveyor.

Two more encoders can be operated in parallel with the encoders for actual value preprocessing and position control in order to collect actual values and measured data.

The indexed acquisition of actual values can preprocess an actual position value at each of the three encoder outputs. The parameter p2502[0...3] is used to select the encoder evaluation for position control.

The parameters of the indexed actual value acquisition are indexed four times. The indexes 1..3 are assigned to the encoder evaluations 1..3. The index 0 is assigned to position control.

The parameter r2521[0...3] can be used to retrieve the current actual values of all connected encoders. For example, the actual position value for position control in r2521[0] is identical with the value r2521[1] if the position control uses encoder evaluation 1. The signal source for a position offset can be set in parameter p2516[0...3].

The absolute encoder adjustment is initiated via p2507[0...3] = 2, and its successful completion is reported via p2507[0...3] = 3. The signal source "Reference point coordinate for the position controller" p2598[0] is interconnected with p2599 during basic positioning. The other signal sources are not interconnected in the standard configuration.

The measuring probe evaluation can be enabled for the encoder evaluation x, which is not assigned to position control, via p2509[x]. The signal sources are assigned via p2510[0...3], the edge evaluation is set via p2511[0...3]. The measured value is available in r2523[x] if, in the status word for encoder x (encoder 0: r2526.0..9, encoder1: 2627.0..2, encoder2: r2628.0..2, encoder3: r2529.0..2) the "Measurement value valid" bit is set.

The actual position values of the different encoders can be read out using parameter r2521[0...3]. These actual position values can be corrected with a signed value from p2513[0...3] after a 0/1 signal from the signal source in p2512[0...3].

In addition, the actual velocity value (r2522[0...3]) and the position offset for absolute encoders p2525[0...3] can be processed for each encoder by the higher-level controller.

Features

- Encoder assignment (p2502[D])
- Absolute encoder adjustment (p2507[E])
- Activate measuring probe evaluation (p2509[0...3])
- Measuring probe evaluation selection (p2510[0...3])
- Measuring probe edge (p2511[0..3])
- Activate actual position value processing, correction value (p2512[0...3])
- Actual position value processing, correction value (p2513[0...3])
- Position offset (p2516[0...3])
- Actual position value (r2521[0...3])
- Actual velocity value (r2522[0...3])

- Measuring probe evaluation/Reference mark search (p2523[0..3])
- Encoder adjustment, offset (p2525[E])
- Status word position controller (r2526)
- Status word encoder1 (r2527)
- Status word encoder2 (r2528)
- Status word encoder3 (r2529)
- EPOS reference point coordinate, signal source (p2598[0..3])
- Function diagram 4010 Position control - Actual position value processing

8.7.2.4 Load gear position tracking

Position tracking enables the load position to be reproduced when using gearboxes. It can also be used to extend the position area.

Position tracking for load gear, functions in the same way as position tracking for the measuring gear (see "Measuring gear position tracking"). Position tracking is activated via parameter p2720.0 = 1. The position tracking of the load gear, however, is only relevant for the motor encoder (encoder 1). The load gear ratio is entered via parameters p2504 and p2505. Position tracking can be activated with rotary axes (modulo) and linear axes.

Position tracking for the load gear can only be activated once for each motor data set MDS.

The load actual position value in r2723 (must be requested via Gn_STW.13, see Section "Control and status words for encoders") comprises the following information:

- Encoder pulses per revolution (p0408)
- Fine resolution per revolution (p0419)
- Virtual number of stored revolutions of a rotary absolute encoder (p2721)
- Load gear ratio (p2504/p2505)
- Measuring gear ratio (p0433/p0432), if p0411.0 = 1

Note

The sum of p0408, p0419 and p2721 is limited to 32 bits.

Note

Load gear problems and solutions, see example in Section Position tracking -> Measuring gear.

Requirements

- Absolute encoder

Features

- Configuration via p2720
- Virtual multiturn via p2721
- Tolerance window for monitoring the position at switching on p2722
- Input of the load gear via p2504 and p2505
- Display via r2723

Example of position area extension

With absolute encoders without position tracking, it must be ensured that the traversing range around 0 is less than half the encoder range, because beyond this range, no unique reference remains after switching on and off (see description on parameter p2507). This traversing range can be extended using the virtual multiturn (p2721).

The following diagram illustrates an absolute encoder that can represent eight encoder revolutions (p0421 = 8).

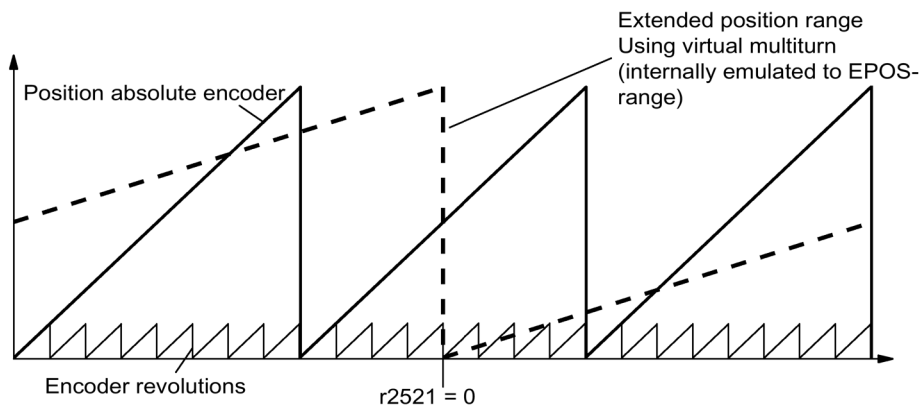

Figure 8-9 Position tracking (p2721 = 24), setting p2504 = p2505 = 1 (gear ratio = 1)

In this example, this means:

- Without position tracking, the position for +/- 4 encoder revolutions around r2521 = 0 LU can be reproduced.
- With position tracking, the position for +/- 12 encoder revolutions (+/- 12 load revolutions with load gear) can be reproduced (p2721 = 24).

Practical example:

For a linear axis, the value for p2721 is set to 262144 for an encoder with p0421 = 4096. This means that +/- 131072 encoder revolutions or load revolutions can be reproduced.

For a rotary axis, a value for p2721 = p0421 is set for an encoder.

Configuration of the load gear (p2720).

The following points can be set by configuring this parameter:

- p2720.0: Activation of position tracking
- p2720.1: Setting the axis type (linear axis or rotary axis)
Here, a rotary axis refers to a modulo axis; the modulo offset can be activated from a higher-level controller or EPOS. With a linear axis, position tracking is mainly used to extend the position area (see section: Virtual multiturn encoder (p2721)).
- p2720.2: Reset position
The position values stored in non-volatile memory are reset in response to the following events:
 - When encoder replacement is detected.
 - When the configuration of the encoder data set (EDS) is modified.
 - When the absolute encoder is adjusted again.

Note

If position tracking of the load gear is activated with parameter p2720[0] = 1 (position gear load tracking) after the encoder is adjusted (p2507 = 3), the adjustment will be reset.

If the encoder is adjusted again when load position tracking is active, the load gear position will be reset (overflows).

The permissible position tracking range is mapped on the reproducible encoder range of EPOS.

It is possible to activate position tracking for several DDS.

Virtual multiturn encoder (p2721)

The number of resolvable load rotations for a rotary absolute encoder with active position tracking can be set by means of the virtual multiturn resolution. It is only editable for rotary axes.

With a rotary absolute encoder (p0404.1 = 1) with activated position tracking (p2720.0 = 1), p2721 can be used to enter a virtual multiturn resolution.

Note

If the gear ratio is not equal to 1, then p2721 always refers to the load side. The virtual resolution, which is required for the load, is then set here.

In the case of rotary axes, the virtual multiturn resolution (p2721) is preset to the multiturn resolution value of the encoder (p0421) and can be altered.

Example: Singleturn encoder

Parameter p0421 is preset to p0421 = 1. However, parameter p2721 can be altered subsequently, e.g. the user can program p2721 = 5. As a result, the encoder evaluation initiates five load rotations before the same absolute value is achieved again.

In the case of linear axes, the virtual multiturn resolution (p2721) is preset to the multiturn resolution value of the encoder (p0421), which is extended by six bits, (max. 32 positive/negative overflows).

The setting for p2721 cannot be edited again afterwards.

Example: Multiturn encoder

For a linear axis, the value for p2721 is set to 262144 for an encoder with p0421 = 4096.

This means that +/- 131072 encoder revolutions or load revolutions can be reproduced.

If, as a result of extension of the multiturn information, the displayable area of r2723 (32 bits) is exceeded, the fine resolution (p0419) must be reduced accordingly.

Tolerance window (p2722)

After switching on, the difference between the stored position and the actual position is determined and, depending on the result, the following is initiated:

Difference within the tolerance window -> the position is reproduced based on the current actual encoder value.

Difference outside the tolerance window -> an appropriate fault (F07449) is output.

The tolerance window is preset to quarter of the encoder range and can be changed.

Note

The position can only be reproduced if, in the powered-down state, the encoder was moved through less than half of the range that it can represent. For the standard EQN1325 encoder, this is 2048 revolutions or half a revolution for singleturn encoders.

Note

The ratio stamped on the gear rating plate is often just a rounded-off value (e.g. 1:7.34). If, for a rotary axis, it is not permissible to have any long-term drift, then the actual ratio of the gearbox teeth must be requested from the gearbox manufacturer.

Multiple drive data sets

Position tracking of the load gear can be activated in multiple drive data sets.

- The load gear is DDS-dependent.
- Load gear position tracking is computed only for the active drive data set and is EDS-dependent.
- The position tracking memory is only available once for each EDS.
- If position tracking is to be continued in different drive data sets with the same mechanical relationships and the same encoder data sets, it must be activated explicitly in all relevant drive data sets. Possible applications for drive data set changeover with continued position tracking:
 - Star/delta changeover
 - Different ramp-up times / controller settings
- When the changeover between drive data sets involves a change in gear unit, the position tracking function starts from the beginning again, i.e. it behaves on changeover as if a POWER ON had occurred.
- For identical mechanical relationships and the same encoder data set, DDS changeover has no effect on the calibration status and reference point status.

Restrictions

- Position tracking cannot be activated for an encoder data set which is used in different drive data sets as encoder1 for different gears. If an attempt is still made to activate position tracking, fault "F07555 Drive encoder: Configuration position tracking" will be displayed with fault value 03 hex.
A check is generally performed to determine whether the load gear is the same in all DDS in which the relevant encoder data set is used.
Load gear parameters p2504[D], p2505[D], p2720[D], p2721[D] and p2722[D] must be identical in this case.
- If an encoder data set is used in one DDS as a motor encoder with position tracking and in another DDS as an external encoder, the position tracking starts from the beginning again, i.e. it behaves in the same way as it would do after a POWER ON.
- If position tracking is reset in one drive data set, it is also reset in all other drive data sets which contain this encoder data set.
- The maximum permissible movement of an axis in an inactive drive data sets is half the encoder range (see p2722: tolerance window).

The table below describes the changeover behavior on transition from one DDS to another. A changeover is always executed by DDS0.

An overview of DDS changeover without position tracking load gear can be found in section "Instructions for data set changeover" in Section "EPOS - referencing".

Table 8- 5 DDS changeover with load gear position tracking

DDS	p0186 (MDS)	p0187 (enc. 1)	p0188 (enc. 2)	p0189 (enc. 3)	Encoder for position control p2502	Mechanical conditions p2504/ p2505/ p2506/ p2503	Position tracking Load gear	Changeover response
0	0	EDS0	EDS1	EDS2	encoder_1	xxx	Activated	-
1	0	EDS0	EDS1	EDS2	encoder_1	xxx	Activated	Changeover during pulse inhibit or operation has no effect
2	0	EDS0	EDS1	EDS2	encoder_1	yyy	Deactivated	Encoder adjustment and referencing bit are reset. Position tracking for EDS0 is no longer calculated and must be re-adjusted when switching back to DDS0.
3	0	EDS0	EDS1	EDS2	encoder_2	xxx	Activated	Position tracking for EDS0 is continued and the referencing bit is reset. ¹⁾
4	0	EDS0	EDS3	EDS2	encoder_2	xxx	Activated	Pulse inhibit/operation: Position tracking for EDS0 is continued and the referencing bit is reset. ¹⁾
5	1	EDS4	EDS1	EDS2	encoder_2	xxx	Activated	Position tracking for EDS4 is newly initiated and the referencing bit is reset. ¹⁾ When switching back to DDS0, the same applies to EDS0.
6	2	EDS5	EDS6	EDS6	encoder_1	zzz	Activated	Position tracking for EDS5 is newly initiated and the referencing bit is reset. ¹⁾ When switching back to DDS0, the same applies for EDS0.
7	3	EDS0	EDS1	EDS2	encoder_1	xxx	Activated	MDS changeover alone during pulse inhibit or operation has no effect

DDS	p0186 (MDS)	p0187 (enc. 1)	p0188 (enc. 2)	p0189 (enc. 3)	Encoder for position control p2502	Mechanical conditions p2504/ p2505/ p2506/ p2503	Position tracking Load gear	Changeover response
8	0	EDS0	EDS1	EDS2	encoder_1	xxx	Deactivated	Pulse inhibit/operation: Referencing bit is reset. ¹⁾ Position tracking for EDS0 is no longer calculated and, as a consequence, the actual position value also changes (the offset correction of the position tracking is canceled). When switching back to DDS0, the position tracking for EDS0 is newly initiated and the referencing bit is reset. ¹⁾ It only makes sense to switch back to DDS0 without a new adjustment in DDS0 if the user did not make a new adjustment in DDS8 and the permissible tolerance window (p2722) was not exited.
9	4	EDS6	EDS0	EDS2	encoder_1	www	Activated	Pulse inhibit/operation: Position tracking for EDS6 is newly initiated and the referencing bit is reset. ¹⁾ When switching back to DDS0, the same applies to EDS0.

¹⁾ The referencing bit (r2684.11) is reset for a DDS changeover. If, in the new DDS, the EDS already has an adjusted encoder, then the referencing bit is set again.

Definitions:

- Position tracking is continued
The behavior of the position tracking during the changeover is the same as it would be if the data set had not even been changed.
- Position tracking is newly initiated (the position actual value can change when the changeover is made!)
The behavior during changeover is the same as the behavior after a POWER ON. The position value read by the absolute encoder is compared to the stored value. If the position difference is within the tolerance window (p2722), the position is corrected correspondingly; if it is outside the range, a corresponding fault F07449 is output
- Position tracking is reset (the position actual value can change when the changeover is made!)
The stored absolute value is rejected and the overflow counter is reset to zero.
- Position tracking is not calculated (the position actual value changes when the changeover is made!)
- The saved absolute value of the position tracking - including the offset correction from the dissolved DDS - is not used.
- www, xxx, yyy, zzz: Different mechanical conditions.
- Additional information: The position tracking memory is only available once for each EDS.

8.7.2.5 Commissioning position tracking load gear using STARTER

The position tracking function can be configured in the "Mechanical system" screen for "Position control" in STARTER.

The "Mechanical system" screen for "Position control" is not accessible unless the function module "Basic positioner" is activated ($r0108.4 = 1$) which means that the function module "Position control" ($r0108.3 = 1$) is automatically activated as well.

The "Basic positioner" function module can be activated via the commissioning wizard or the drive configuration (configure DDS) (configuration "Closed-loop control structure" - checkbox "Basic positioner").

Configuring the position tracking load gear function

Configure the "Position tracking load gearbox" function in the following screens of the STARTER commissioning tool:

- In the "Mechanical system configuration" screen in the commissioning wizard.
- OR
- In the project navigator under "Drive" > "Technology" > "Position control" in the "Mechanical System" screen.

8.7.2.6 Function diagrams and parameters

Function diagrams (see SINAMICS S120/S150 List Manual)

- 4010 Position control - Actual position value processing (r0108.3 = 1)
- 4704 Encoder evaluation - Position and temperature sensing, encoders 1 ... 3
- 4710 Encoder evaluation - Actual speed value and pole position sensing, motor encoder (encoder1)

Overview of important parameters (see SINAMICS S120/S150 List Manual)

- p2502[0...n] LR encoder assignment
- p2503[0...n] LR length unit LU per 10 mm
- p2504[0...n] LR motor/load motor revolutions
- p2505[0...n] LR motor/load load revolutions
- p2506[0...n] LR length unit LU per load revolution
- r2520[0...n] CO: LR actual position value processing encoder control word
- r2521[0...n] CO: LR actual position value
- r2522[0...3] CO: LR actual velocity value
- r2523[0...3] CO: LR measured value
- r2524 CO: LR LU/revolutions
- p2525[0...n] CO: LR encoder adjustment offset
- r2526.0...9 CO/BO: LR status word
- p2720[0...n] Load gear configuration
- p2721[0...n] Load gear, absolute encoder, rotary revolutions, virtual
- p2722[0...n] Load gear, position tracking, tolerance window
- r2723[0...n] CO: Load gear absolute value
- r2724[0...n] CO: Load gear position difference
- p2730[0...3] BI: LR actual position value processing correction negative act. (edge)

8.7.3 Position controller

The position controller is a PI controller. The P gain can be adapted using the product of connector input p2537 (position controller adaptation) and parameter p2538 (Kp).

Using connector input p2541 (limit), the speed setpoint of the position controller can be limited without precontrol. This connector input is pre-interconnected with connector output p2540.

The position controller is enabled by an AND link of the binector inputs p2549 (position controller 1 enable) and p2550 (position controller 2 enable).

The position setpoint filter (p2533 time constant position setpoint filter) is a PT1 element, the symmetrizing filter as dead time element (p2535 symmetrizing filter speed precontrol (dead time) and PT1 element (p2536 symmetrizing filter speed precontrol (PT1))). The speed precontrol p2534 (factor, speed precontrol) can be disabled via the value 0.

Features

- Symmetrization (p2535, p2536)
- Limiting (p2540, p2541)
- Precontrol (p2534)
- Adaptation (p2537, p2538)

Note

We only recommend that experts use the position controller functions without using the basic positioner.

Function diagrams (see SINAMICS S120/S150 List Manual)

- 4015 Position control - Position controller (r0108.3 = 1)

Overview of important parameters (see SINAMICS S120/S150 List Manual)

- p2533[0...n] LR position setpoint filter time constants
- p2534[0...n] LR speed feedforward control factor
- p2535[0...n] LR speed feedforward control balancing filter dead time
- p2536[0...n] LR speed feedforward control balancing filter PT1
- p2537 CI: LR position controller adaptation
- p2538[0...n] LR proportional gain
- p2539[0...n] LR integral time
- p2540 CO: LR position controller output speed limit
- p2541 CI: LR position controller output speed limit signal source

8.7.4 Monitoring functions

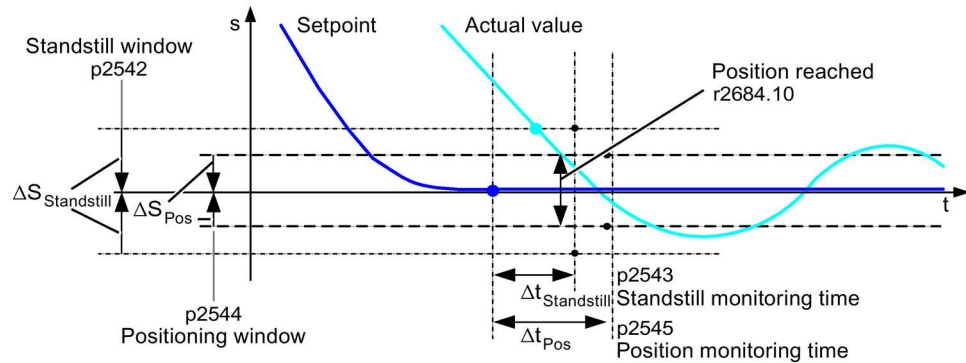

Figure 8-10 Standstill monitoring, positioning window

The position controller monitors the standstill, positioning and following error.

Standstill monitoring is activated via binector inputs p2551 (setpoint stationary) and p2542 (standstill window). If the standstill window is not reached once the monitoring time (p2543) has elapsed, fault F07450 is triggered.

Positioning monitoring is activated via binector inputs p2551 (setpoint stationary), p2554 = "0" (travel command not active) and p2544 (positioning window). Once the monitoring time (p2545) has elapsed, the positioning window is checked once. If this is not reached, fault F07451 is triggered.

The standstill monitoring and the positioning monitoring can be deactivated using the value "0" in p2542 and p2544. The standstill window should be greater than or equal to the positioning window ($p2542 \geq p2544$). The standstill monitoring time should be less than or equal to the positioning monitoring time ($p2543 \leq p2545$).

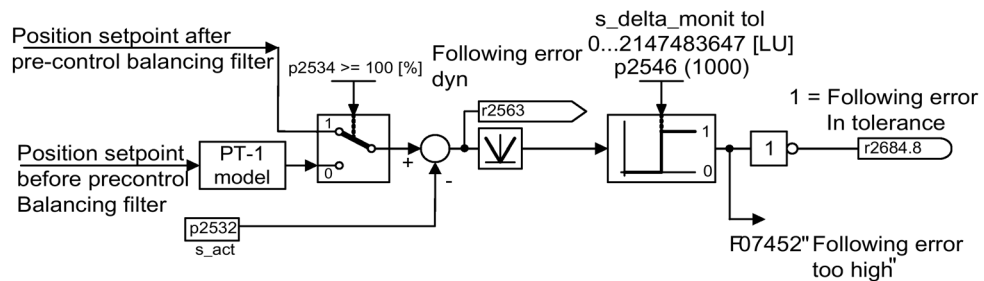

Figure 8-11 Following error monitoring

Following error monitoring is activated via p2546 (following error tolerance). If the absolute value of the dynamic following error (r2563) is greater than p2546, fault F07452 is output and bit r2684.8 is reset.

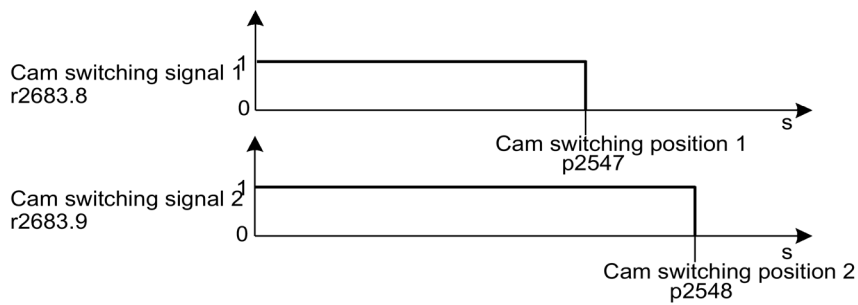

Figure 8-12 Cam controllers

The position controller has two cam controllers. If cam position p2547 or p2548 is passed in the positive direction ($r2521 > p2547$ or $p2548$), then cam signals r2683.8 and r2683.9 are reset.

Features

- Standstill monitoring (p2542, p2543)
- Positioning monitoring (p2544, p2545)
- Dynamic following error monitoring (p2546, r2563)
- Cam controllers (p2547, p2548, p2683.8, p2683.9)

Function diagrams (see SINAMICS S120/S150 List Manual)

- 4020 Position control - Standstill monitoring / positioning monitoring ($r0108.3 = 1$)
- 4025 Position control - Dynamic following error monitoring, cam controllers ($r0108.3 = 1$)

Overview of important parameters (see SINAMICS S120/S150 List Manual)

- p2530 CI: LR position setpoint
- p2532 CI: LR actual position value
- p2542 LR standstill window
- p2543 LR standstill monitoring time
- p2544 LR positioning window
- p2545 LR position monitoring time
- p2546[0...n] LR dynamic following error monitoring tolerance
- p2547 LR cam switching position 1
- p2548 LR cam switching position 2
- p2551 BI: LR setpoint message present
- p2554 BI: LR travel command message active
- r2563 CO: LR following error, dynamic model
- r2683.8 CO/BO: EPOS status word 1;
actual position value \leq cam switching position 1
- r2683.9 CO/BO: EPOS status word 1;
actual position value \leq cam switching position 2
- r2684.0...15 CO/BO: EPOS status word 2

8.7.5 Measuring probe evaluation and reference mark search

The "Reference mark search" and "Probe evaluation" functions can be initiated and carried out via binector inputs p2508 and p2509. Binector inputs p2510 and p2511 define the mode for measurement probe evaluation.

The probe signals are recorded via the encoder status and control word. To speed up signal processing, direct measuring probe evaluation can be activated by selecting the input terminals for probes 1/2 via p2517 and p2518. Measuring probe evaluation is carried out in the position controller cycle, whereby the set send cycle of the controller (r2064[1]) must be an integer multiple of the position controller cycle (p0115[4]).

The system outputs a message if the same probe input is already being used (see also p0488, p0489, p0580, and p0680).

The appropriate function is started using a 0/1 edge at the appropriate input p2508 or p2509 via the encoder control word. Status bit r2526.1 (reference function) signals that the function is active (feedback from the encoder status word). Status bit r2526.2 (measurement value valid) shows the presence of the measurement required r2523 (position for reference mark or measurement probe).

Once the function is complete (position determined for reference mark or measurement probe), r2526.1 (reference function active) and r2526.2 (measurement valid) continue to remain active and the measurement is provided by r2523 until the corresponding input p2508 or p2509 is reset (0 signal).

If the function (reference mark search or measuring probe evaluation) has still not been completed and the corresponding input p2508 or p2509 is reset, then the function is interrupted via the encoder control word and status bit r2526.1 (reference function active) is reset via the encoder status word.

If both binector inputs p2508 and p2509 are simultaneously set, this causes the active function to be interrupted and no function is started. This is indicated using alarm A07495 "reference function interrupted" and remains until the signals at the binector inputs are reset. The alarm is also generated if, during an activated function (reference mark search or measuring probe evaluation) a fault is signaled using the encoder status word.

If the "position control" function module is selected, these parameters (p2508 to p2511) are preassigned with "0". If the "basic positioner" function module is selected, the "reference mark search" (for search for reference point) and "measurement probe evaluation" (for the flying referencing function) functions are initiated by the "basic positioner" function module and feedback (r2526, r2523) returned to this.

Function diagrams (see SINAMICS S120/S150 List Manual)

- 4010 Position control - Actual position value processing (r0108.3 = 1)
- 4720 Encoder evaluation - Encoder interface, receive signals, encoders 1 ... 3
- 4730 Encoder evaluation - Encoder interface, send signals, encoders 1 ... 3

Overview of important parameters (see SINAMICS S120/S150 List Manual)

- p2508[0...3] BI: LR activate reference mark search
- p2509[0...3] BI: LR activate measuring probe evaluation
- p2510[0...3] BI: LR measuring probe evaluation, selection
- p2511[0...3] BI: LR measuring probe evaluation edge
- p2517[0...2] LR direct probe 1
- p2518[0...2] LR direct probe 2
- r2523[0...3] CO: LR measured value
- r2526.0...9 CO/BO: LR status word

8.7.6 Commissioning

The "position control" function module is integrated in the system as follows:

Commissioning

The configuration screen for "Position control" in STARTER is not made accessible unless the function module "Basic positioner" is activated (r0108.4 = 1) which means that the function module "Position control" (r0108.3 = 1) is automatically activated as well.

The "basic positioner" function module can be activated via the commissioning wizard or the drive configuration (configure DDS) (configuration "Closed-loop control structure" - checkbox "Basic positioner").

To ensure correct, error-free operation of the basic positioner, it is absolutely essential that the "Position control" function module is activated and the position control correctly configured.

If the "position control" function module is active, and to optimize the speed controller, a function generator signal is interconnected to the speed controller input p1160, then the position controller monitoring functions respond. To prevent this from happening, the position controller must be disabled (p2550 = 0) and switched to the tracking mode (p2655 = 1, for control using PROFIdrive telegram 110 PosSTW.0 = 1). In this way, the monitoring functions are switched off and the position setpoint is tracked.

Function diagrams (see SINAMICS S120/S150 List Manual)

- 4010 Position control - Actual position value processing (r0108.3 = 1)
- 4015 Position control - Position controller (r0108.3 = 1)
- 4020 Position control - Standstill monitoring / positioning monitoring (r0108.3 = 1)
- 4025 Position control - Dynamic following error monitoring, cam controllers (r0108.3 = 1)

Overview of important parameters (see SINAMICS S120/S150 List Manual)

- r0108 Drive object function module
- p1160[0...n] CI: Speed controller, speed setpoint 2
- p2550 BI: Position control enable 2

8.8 Basic positioner

The basic positioner (EPOS) is used to position linear and rotary axes (modulo) in absolute/relative terms with motor encoder (indirect measuring system) or machine encoder (direct measuring system). EPOS is available for servo control and vector control.

For the basic positioner functionality, STARTER provides graphic guides through the configuration, commissioning and diagnostic functions. A control panel in STARTER supports you when operating the basic positioner and when operating in the closed-loop speed controlled mode.

The position control ($r0108.3 = 1$) is also automatically activated when activating the basic positioner ($r0108.4 = 1$) using the commissioning wizards of STARTER. The required BICO interconnections are automatically made.

Note

The basic positioner requires the position controller functions. The BICO interconnections, which are automatically made by the basic positioner when activated, must be changed by experienced users (experts) only.

Functions of the position control

This means that the following functions are available for the position control:

- Standstill monitoring
- Position monitoring
- Dynamic following error monitoring
- Cam controllers
- Modulo function
- Probe evaluation

For more information, see Chapter "Position control (Page 454)".

Functions of the basic positioner

In addition, the following functions can be carried out using the basic positioner:

- Mechanical system
 - Backlash compensation
 - Modulo offset
 - Position tracking of the load gear (motor encoder) with absolute encoders
- Limits
 - Traversing profile limits
 - Traversing range limits
 - Jerk limitation

- Referencing or adjustment
 - Setting reference point (with stationary axis)
 - Reference point approach
(autonomous mode including reversing cam functionality, automatic direction of rotation reversal, referencing to "cams and encoder zero mark" or only "encoder zero mark" or "external equivalent zero mark (BERO)")
 - Flying referencing
(superimposed referencing possible during "normal" traversing with the aid of the measurement probe evaluation (normally evaluation of a BERO, for example). Superimposed function for the modes "Jog", "Direct setpoint specification / MDI" and "Traversing blocks")
 - Referencing with incremental measuring systems
 - Absolute encoder adjustment
- Traversing blocks operating mode
 - Positioning using traversing blocks that can be saved in the drive unit including block change enable conditions and specific tasks for an axis that was previously referenced
 - Traversing block editor using STARTER
 - A traversing block contains the following information:
 - Traversing block number
 - Job (e.g. positioning, wait, GOTO block step, setting of binary outputs)
 - Motion parameters (target position, velocity override for acceleration and deceleration)
 - Mode (e.g. skip block, block change enable conditions such as "Continue_with_stop" and "Continue_flying")
 - Task parameters (e.g. delay time, block step conditions)
- Direct setpoint specification mode (MDI)
 - Positioning (absolute, relative) and setting-up (endless closed-loop position control) using direct setpoint specifications (e.g. via the PLC or process data)
 - It is always possible to influence the motion parameters during traversing (on-the-fly setpoint acceptance) as well as on-the-fly change between the Setup and Positioning modes
- Jog mode
 - Position-controlled traversing of the axis with the switchable modes "Endless position-controlled" or "Incremental jog" (to traverse an "increment")
- Standard PROFIdrive positioning telegrams are available (telegrams 7, 9 and 110), the selection of which automatically establishes the internal "connection" to the basic positioner
- Control via PROFIdrive telegrams 7 and 110
(for further information, see Section "Cyclic communication (Page 704)" and SINAMICS S120/S150 List Manual)

8.8.1 Mechanical system

When mechanical force is transferred between a machine part and its drive, generally backlash occurs. If the mechanical system was to be adjusted/ designed so that there was absolutely no play, this would result in high wear. Thus, backlash (play) can occur between the machine component and the encoder. For axes with indirect position sensing, mechanical backlash results in a falsification of the traversing distance, as, at direction reversal, the axis travels either too far or not far enough corresponding to the absolute value of the backlash.

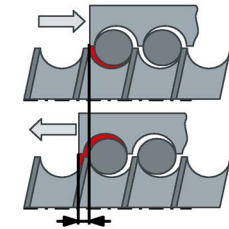

Reversal error:
p2583

Figure 8-13 Backlash compensation

Note

The backlash compensation is active with the following settings:

- The axis has been referenced for incremental measuring systems
- The axis has been adjusted for absolute measuring systems

In order to compensate the backlash, the determined backlash must be specified in p2583 with the correct polarity. At each direction of rotation reversal, the actual axis value is corrected dependent on the actual traversing direction and displayed in r2667. This value is taken into account in the actual position value using p2516 (position offset).

If a stationary axis is referenced by setting the reference point or an adjusted axis is powered-up with an absolute encoder, then the setting of parameter p2604 (reference point approach, starting direction) is relevant for switching-in the compensation value.

Table 8- 6 The compensation value is switched in as a function of p2604

p2604	Traversing direction	Switch in compensation value
0	Positive	None
	Negative	Immediately
1	Positive	Immediately
	Negative	None

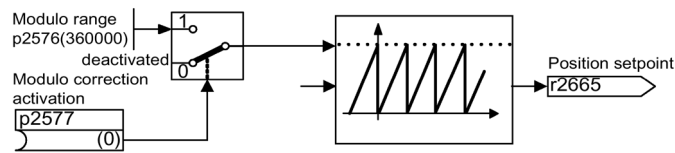

Figure 8-14 Modulo offset

A modulo axis has an unrestricted traversing range. The value range of the position repeats itself after a specific value that can be parameterized (the modulo range or axis cycle), e.g. after one revolution: 360° -> 0°. The modulo range is set in parameter p2576, the offset is activated with parameter p2577. The modulo offset is undertaken at the setpoint end. This is provided with the correct sign via connector output r2685 (correction value) to appropriately correct the actual position value. EPOS initiates the activation of the correction via a rising edge of binector output r2684.7 (activate correction) (r2685 (correction value) and r2684.7 (activate correction) are already connected as standard with the corresponding binector/connector input of the actual position value processing). Absolute positioning details (e.g. in a traversing task) must always be within the modulo range. Modulo offset can be activated for linear and rotary length units. The traversing range cannot be limited by a software limit switch.

With active modulo offset and the application of absolute encoders, as a result of potential encoder overflows, it must be ensured that there is an integer ratio v between the multiturn resolution and the modulo range.

The ratio v can be calculated as follows:

- Motor encoder without position tracking:

$$v = p0421 \times p2506 \times p0433 \times p2505 / (p0432 \times p2504 \times p2576)$$
- Motor encoder with position tracking for the measuring gear:

$$v = p0412 \times p2506 \times p2505 / (p2504 \times p2576)$$
- Motor encoder with position tracking for the load gear:

$$v = p2721 \times p2506 \times p0433 / (p0432 \times p2576)$$
- Motor encoder with position tracking for the load and measuring gear:

$$v = p2721 \times p2506 / p2576$$
- Direct encoder without position tracking:

$$v = p0421 \times p2506 \times p0433 / (p0432 \times p2576)$$
- Direct encoder with position tracking for the measuring gear:

$$v = p0412 \times p2506 / p2576$$

With position tracking it is recommended to change p0412 or p2721.

Features

- Backlash compensation (p2583)
- Modulo offset (p2577)

Commissioning with STARTER

In STARTER, the "Mechanical system" screen form can be found under "Position control".

Function diagrams (see SINAMICS S120/S150 List Manual)

- 3635 EPOS - Interpolator (r0108.4 = 1)
- 4010 Position control - Actual position value processing (r0108.3 = 1)

Overview of important parameters (see SINAMICS S120/S150 List Manual)

- p2576 EPOS modulo offset modulo range
- p2577 BI: EPOS modulo offset activation
- p2583 EPOS backlash compensation
- r2684.0...15 CO/BO: EPOS status word 2
- r2685 CO: EPOS correction value

8.8.2 Limits

The velocity, acceleration and deceleration can be limited and the software limit switches and STOP cams set.

Features

- Traversing profile limits
 - Maximum velocity (p2571)
 - Maximum acceleration (p2572) / maximum deceleration (p2573)
- Traversing range limits
 - Software limit switch (p2578, p2579, p2580, p2581, p2582)
 - STOP cams (p2568, p2569, p2570)
- Jerk limitation
 - Jerk limitation (p2574)
 - Activation of jerk limitation (p2575)

Maximum velocity

The maximum velocity of an axis is defined using parameter p2571. The velocity should not be set to be greater than the maximum speeds in r1084 and r1087.

The drive is limited to this velocity if a higher velocity is specified or programmed via the override (p2646) for the reference point approach or is programmed in the traversing block.

Parameter p2571 (maximum velocity) defines the maximum traversing velocity in units 1000 LU/min. If the maximum velocity is changed, then this limits the velocity of a traversing task that is presently being executed.

This limit is only effective in the positioning mode for:

- Jog mode
- Processing traversing blocks
- Direct setpoint specification / MDI for positioning and setting-up
- Reference point approach

Maximum acceleration/deceleration

Parameter p2572 (maximum acceleration) and p2573 (maximum deceleration) define the maximum acceleration and the maximum deceleration. In both cases, the units are 1000 LU/s².

Both values are relevant for:

- Jog mode
- Processing traversing blocks
- Direct setpoint specification / MDI for positioning and setting up
- Reference point approach

The parameters do not have any effect when faults occur with the fault responses OFF1/OFF2/OFF3.

In the traversing blocks mode, the acceleration and deceleration can be set in multiple integer steps (1%, 2% ... 100%) of the maximum acceleration and deceleration. The acceleration/deceleration override (assignment of 4000 hex = 100%) is specified in the "Direct setpoint specification / MDI" mode for positioning and setting up.

Note

A maximum acceleration or deceleration dependent on the actual velocity (transitioned acceleration) is not supported.

Note

When using the PROFIdrive telegram 110, the velocity override is already connected and has to be supplied by the telegram.

Software limit switch

The connector inputs p2578 (software limit switch minus) and p2579 (software limit switch plus) limit the position setpoint if the following prerequisites are fulfilled:

- The software limit switches are activated (p2582 = "1")
- The reference point is set (r2684.11 = 1)
- The modulo correction is not active (p2577 = "0")

The connector inputs are, in the factory setting, linked to the connector output p2580 (software limit switch minus) and p2581 (software limit switch plus).

STOP cam

A traversing range can, on the one hand, be limited per software using the software limit switches and on the other hand, the traversing range can be limited per hardware. In this case, the functionality of the STOP cam (hardware limit switch) is used. The function of the STOP cams is activated by the 1 signal on the binector input p2568 (activation of STOP cams).

Once enabled, the activity of binector inputs p2569 (STOP cam, minus) and p2570 (STOP cam, plus) is checked. These are low active; this means if a 0 signal is present at binector input p2569 or p2570, then these are active.

When a STOP cam (p2569 or p2570) is active, the current motion is stopped with OFF3 and the appropriate status bit r2684.13 (STOP cam minus active) or r2684.14 (STOP cam plus active) is set.

When an axis has approached a STOP cam, only motion that allows the axis to move away from the cam is permitted (if both STOP cams are actuated, then no motion is possible). When the STOP cam is exited, this is identified by the 0/1 edge in the permitted traversing direction which means that the corresponding status bits (r2684.13 or r2684.14) are reset.

Jerk limitation

Acceleration and deceleration can change suddenly if jerk limiting has not been activated. The diagram below shows the traversing profile when jerk limitation has not been activated. The maximum acceleration (a_{\max}) and deceleration (d_{\max}) are effective immediately. The drive accelerates until the target speed (v_{target}) is reached and then switches to the constant velocity phase.

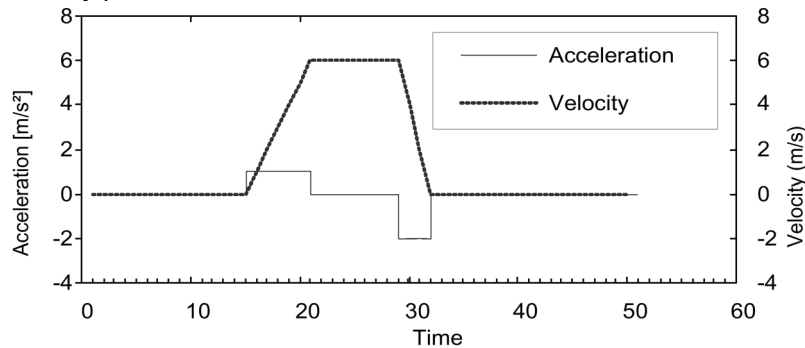

Figure 8-15 Without jerk limitation

Jerk limitation can be used to achieve a ramp-like change of both variables, which ensures "smooth" acceleration and braking as shown in the diagram below. Ideally, acceleration and deceleration should be linear.

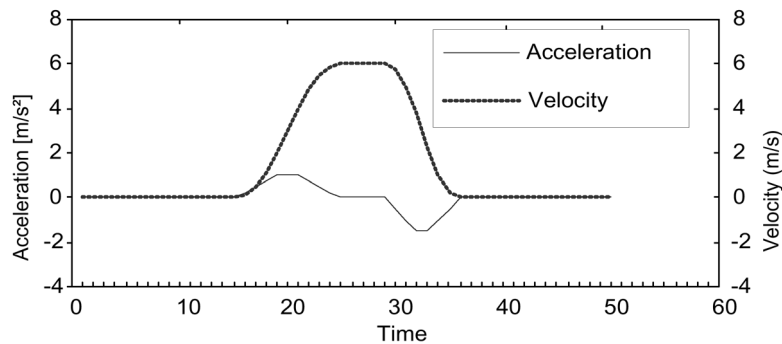

Figure 8-16 Activated jerk limitation

The maximum gradient (r_k) can be set in parameter p2574 (jerk limitation) in the unit LU/s^3 for both acceleration and braking. The resolution is 1000 LU/s^3 . To activate the limitation permanently, set parameter p2575 (Activate jerk limitation) to 1. In this case, limitation cannot be activated or deactivated in traversing block mode by means of the command "JERK". Switching the limitation on/off in the traversing block mode requires parameter p2575 (Activate jerk limitation) to be set to zero. The status signal r2684.6 (Jerk limitation active) indicates whether or not jerk limitation is active.

The limitation is effective for the following activities:

- Jog mode
- Processing traversing blocks
- Direct setpoint specification / MDI for positioning and setting up
- Reference point approach
- Stop responses due to alarms

Jerk limitation is not active when messages are generated with stop responses OFF1 / OFF2 / OFF3.

Starting against a closed brake

Under EPOS, if the drive should start against a closed brake, for example, for a suspended load, then the enable signal p0899.2 is briefly withdrawn. The drive pulses are canceled and fault F07490 is output.

To avoid this happening, using p1513 activate a supplementary torque which corresponds to the brake holding torque. As a result, after releasing the brake, the load cannot sag and the drive remains in closed-loop control without fault F07490 being output.

Function diagrams (see SINAMICS S120/S150 List Manual)

- 3630 EPOS - Traversing range limits (r0108.4 = 1)

Overview of important parameters (see SINAMICS S120/S150 List Manual)

- p2571 EPOS maximum speed
- p2572 EPOS maximum acceleration
- p2573 EPOS maximum delay
- p2646 CI: EPOS velocity override

Software limit switch

- p2578 CI: EPOS software limit switch, minus signal source
- p2579 CI: EPOS software limit switch, plus signal source
- p2580 CO: EPOS software limit switch, minus
- p2581 CO: EPOS software limit switch, plus
- p2582 BI: EPOS software limit switch activation
- r2683.0...14 CO/BO: EPOS status word 1

STOP cam

- p2568 BI: EPOS STOP cam activation
- p2569 BI: EPOS STOP cam, minus
- p2570 BI: EPOS STOP cam, plus
- r2684.0...14 CO/BO: EPOS status word 2

Jerk limitation

- p2574 EPOS jerk limitation
- p2575 BI: EPOS jerk limitation activation

8.8.3 EPOS and safe setpoint velocity limitation

If safe speed monitoring (SLS) or the safe direction motion monitoring (SDI) is also to be used at the same time as the EPOS positioning function, EPOS must be informed about the activated monitoring limits. Otherwise these speed monitoring limits can be violated by the EPOS setpoint input. By monitoring the limit value, if violated, the drive is stopped therefore exiting the intended motion sequence. In this case, the relevant safety faults are output first, and then the sequential faults created by EPOS.

Using parameter r9733, the safety functions offer EPOS setpoint limiting values, which when taken into account, prevent the safety limit value being violated.

In order to prevent a safety limit violation by the EPOS setpoint specification, you must transfer the setpoint limit value (r9733) as follows to the maximum speed setpoint of EPOS (p2594):

- r9733[0] = p2594[1]
- r9733[1] = p2594[2]

In this regard you must set the delay time for SLS/SOS (p9551), so that the relevant safety monitoring function only becomes active after the maximum required time for the speed to be reduced below the limit. This required braking time is determined by the current speed, the jerk limit in p2574 and the maximum delay in p2573.

8.8.4 Referencing

After a machine has been switched on, for positioning, the absolute dimension reference must be established to the machine zero. This procedure is referred to as referencing. The following referencing types are possible:

- Setting the reference point (all encoder types)
- Incremental encoder
 - Active referencing (reference point approach; p2597 = 0):
 - Reference cams and encoder zero mark (p2607 = 1)
 - Encoder zero mark (p0495 = 0 or p0494 = 0)
 - External zero mark (p0495 ≠ 0 or p0494 ≠ 0)
- Flying referencing (passive; p2597 = 1)
- Absolute encoder
 - Absolute encoder adjustment
 - Flying referencing (passive; p2597 = 1)

Note

Observe the information about the parameters in Chapter "Function diagrams and parameters (Page 493)".

A connector input is provided to enter reference point coordinates for all types of referencing. This allows, e.g. changes/input via the higher-level controller. However, to permanently enter the reference point coordinate, an adjustable parameter for this quantity is also required. As standard, this adjustable parameter p2599 is interconnected to connector input p2598.

Features

- Reference point offset (p2600)
- Reversing cams (p2613, p2614)
- Reference cam (p2612)
- Binector input start (p2595)
- Binector input setting (p2596)
- Velocity override (p2646)
- Reference point coordinate (p2598, p2599)
- Referencing type selection (p2597)
- Absolute encoder adjustment (p2507)

Note

Referencing of distance-coded zero marks is not supported.

Set reference point

The reference point can be set using a 0/1 edge at binector input p2596 (set reference point) if no traversing commands are active and the actual position value is valid (p2658 = 1 signal). A reference point can also be set for an intermediate stop.

The current actual position of the drive is set here as the reference point using the coordinates specified by connector input p2598 (reference point coordinates). The setpoint (r2665) is adjusted accordingly.

This function also uses actual position value correction for the position controller (p2512 and p2513). Connector input p2598 is connected to adjustable parameter p2599 as standard. The binector input is not effective for the traversing task being presently executed.

Absolute encoder adjustment

Absolute encoders have to be adjusted during commissioning. After the machine has been switched off, the position information of the encoder is retained.

When p2507 = 2 is entered, using the reference point coordinate in p2599, an offset value (p2525) is determined. This is used to calculate the actual position value (r2521). Parameter p2507 signals the adjustment with a "3" - in addition bit r2684.11 (reference point set) is set to "1".

The offset of the encoder adjustment (p2525) should be saved in a non-volatile fashion (RAM to ROM) to permanently save it.

Note

If an adjustment is lost for an already adjusted axis, the axis will remain unadjusted even after a POWER ON of the drive unit. The axis needs to be adjusted again in such cases.

Rotary absolute encoder

During adjustment with the rotary absolute encoder, a range is aligned symmetrically around the zero point with half the encoder range within which the position is restored after switch off/on.

If position tracking is deactivated ($p2720.0 = 0$), only one encoder overflow is permitted to occur in this range (for further information, see Section Actual position value processing (Page 454)).

If the reference point ($p2599$) is in the encoder range, the actual position value is set to the reference point during adjustment. Otherwise, adjustment is canceled with F07443.

NOTICE

Material damage caused when using the encoder outside the defined encoder range

If a rotary absolute encoder is used outside the defined encoder range, then after switching off/switching on, undesirable motion can occur. This can damage the machine.

- After adjustment, ensure that the encoder range that has been set up is not exited.
- Activate position tracking ($p2720.0$) if there is a risk that the encoder range is exited.

Linear absolute value encoder

No overflow occurs with linear absolute encoders, which means that the position can be restored within the entire traversing range after switch off/on once adjustment has been carried out. During adjustment, the actual position value is set in line with the reference point.

Referencing with DRIVE-CLiQ encoders

DRIVE-CLiQ encoders are available as either "multiturn" or "singleturn" absolute encoders. If the "referencing" function is selected via the PROFIdrive encoder interface and if a DRIVE-CLiQ encoder or other type of absolute encoder is connected via the DRIVE-CLiQ interface, the zero point of the singleturn position is used as the reference point.

Further information on commissioning DRIVE-CLiQ encoders is provided in the SINAMICS S120 Commissioning Manual.

Reference point approach for incremental measurement systems

With the reference point approach (in the case of an incremental measuring system), the drive is moved to its reference point. In so doing, the drive itself controls and monitors the complete referencing cycle.

Incremental measuring systems require that after the machine has been powered up, the absolute dimension reference is established to the machine zero point. When powering-up the actual position value x_0 in the non-referenced state is set to $x_0 = 0$. Using the reference point approach, the drive can be reproducibly moved to its reference point. The geometry with a positive starting direction (p2604 = "0") is shown in the following.

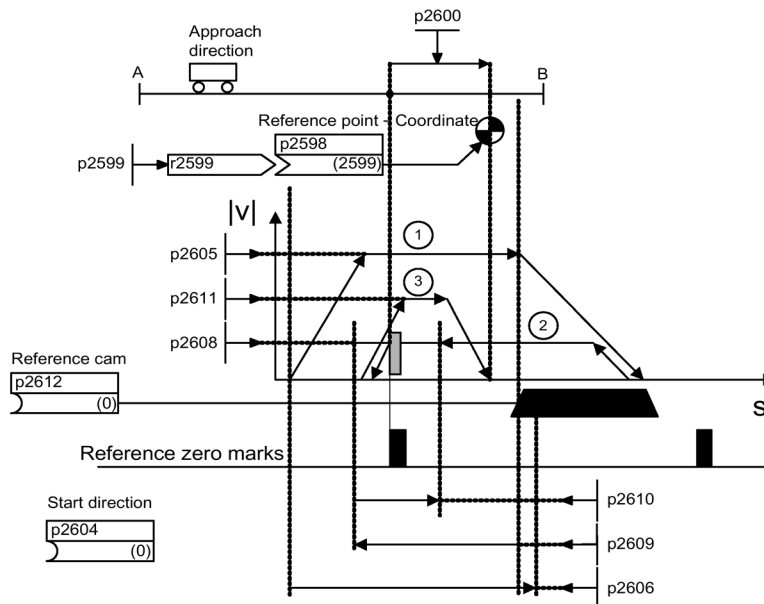

Figure 8-17 Example: Reference point approach with reference cam

The signal on binector input p2595 (start referencing) is used to trigger travel to the reference cam (p2607 = 1) if search for reference is selected at the same time (0 signal at binector input p2597 (referencing type selection)). The signal in binector input p2595 (start referencing) must be set during the entire referencing process otherwise the process is aborted. Once started, the status signal r2684.11 (reference point set) is reset.

The software limit switch monitoring is inactive during the complete reference point approach; only the maximum traversing range is checked. The SW limit switch monitoring is, if required, re-activated after completion.

The velocity override set is only effective during the search for the reference cam (step 1). This ensures that the "cam end" and "zero mark" positions are always overrun at the same speed. If signal propagation delays arise during switching processes, this ensures that the offset caused during establishment of position is the same in each referencing process.

Axes that only have one zero mark over their complete traversing or modulo range are designated with parameter p2607 = 0 (no reference cam present). After starting the referencing process, synchronization to the reference zero marks is started straight away (see step 2) for these axes.

Step 1: Travel to the reference cam

If there is no reference cam present ($p2607 = 0$), go to step 2.

When the referencing process is started, the drive accelerates at maximum acceleration ($p2572$) to the reference cam approach velocity ($p2605$). The direction of the approach is determined by the signal of binector input $p2604$ (reference point approach start direction).

When the reference cam is reached, this is communicated to the drive using the signal at binector input $p2612$ (reference cam); the drive then brakes down to standstill with the maximum deceleration ($p2573$).

If a signal at binector input $p2613$ (reversing cam, MINUS) or at binector input $p2614$ (reversing cam, PLUS) is detected during reference point approach, the search direction is reversed.

If the minus reversing cam is approached in the positive direction of travel or the plus reversing cam in the negative direction of travel, fault F07499 (EPOS: reversing cam approached with the incorrect traversing direction) is output. In this case, the wiring of the reversing cams (BI: $p2613$, BI: $p2614$) or the direction of approach to the reversing cam must be checked.

The reversing cams are low active. If both reversing cams are active ($p2613 = "0"$ and $p2614 = "0"$), the drive remains stationary. As soon as the reference cam is found, then synchronization to the reference zero mark is immediately started (refer to step 2).

If the axis leaves its start position and travels the distance defined in parameter $p2606$ (max. distance to reference cam) heading towards the reference cam without actually reaching the reference cam, the drive remains stationary and fault F07458 (reference cam not found) is issued.

If the axis is already located at the cam, when referencing is started, then traversing to the reference cam is not executed, but synchronization to the reference zero mark is immediately started (refer to step 2).

Note

The velocity override is effective during the search for the cam. By changing the encoder data set, status signal $r2684.11$ (reference point set) is reset.

The cam switch must be able to supply both a rising and a falling edge. For a reference point approach with evaluation of the encoder zero mark, for increasing actual position values the 0/1 edge is evaluated and for decreasing actual position values, the 1/0 edge. Inversion of the edge evaluation is not possible at the sensor zero mark.

If the length measuring system has several zero marks which repeat at cyclic intervals (e.g. incremental, rotary measuring system), you must ensure that the cam is adjusted so that the same zero mark is always evaluated.

The following factors may impact the behavior of the "reference cam" control signal:

- Switching accuracy and time delay of reference cam switch
 - Position controller cycle of drive
 - Interpolation cycle of drive
 - Temperature sensitivity of machine's mechanical system
-

**Step 2: Synchronization to the reference zero mark
(encoder zero mark or external zero mark)**

Reference cam available (p2607 = 1):

In step 2, the drive accelerates to the velocity specified in p2608 (zero mark approach velocity) in the direction opposite to that specified using binector input p2604 (reference point approach start direction). The zero mark is expected at distance p2609 (max. distance to zero mark). The search for the zero mark is active (status bit r2684.0 = "1" (reference point approach active)) as soon as the drive leaves the cam (p2612 = "0") and is within the tolerance band for evaluation (p2609 - p2610). If the position of the zero mark is known (encoder evaluation), the actual position of the drive can be synchronized using the zero mark. The drive starts the search for reference (refer to step 3). The distance moved between the end of the cam and the zero mark is displayed in diagnostics parameter r2680 (difference between the cam - zero mark).

- Encoder zero mark available (p0494 = 0 or p0495 = 0)¹⁾, no reference cams (p2607 = 0):

Synchronization to the reference zero mark begins as soon as the signal at binector input p2595 (start referencing) is detected. The drive accelerates to the velocity, specified in parameter p2608 (zero mark approach velocity) in the direction specified by the signal of binector input p2604 (reference point approach start direction).

The drive synchronizes to the first zero mark and then starts to travel towards the reference point (refer to step 3).

Note

In this case the direction of approach to the reference zero mark is the opposite to the axes with reference cams!

- External zero mark available (p0494 ≠ 0 or p0495 ≠ 0)¹⁾, no reference cams (p2607 = 0):

Synchronization to an external zero mark begins as soon as the signal at binector input p2595 (start referencing) is detected. The drive accelerates to the velocity, specified in parameter p2608 (zero mark approach velocity) in the direction specified by the signal of binector input p2604 (reference point approach start direction). The drive synchronizes to the first external zero mark (p0494 or p0495)¹⁾. The drive continues to travel with the same velocity and travel is started to the reference point (refer to step 3).

Note

The velocity override is inoperative during this process.

An equivalent zero mark can be set and the corresponding digital input selected using parameters p0494 or p0495¹⁾ (equivalent zero mark input terminal). As standard, for increasing actual position values, the 0/1 edge is evaluated and for decreasing actual position values, the 1/0 edge. For the equivalent zero mark, this can be inverted using parameter p0490 (invert measuring probe or equivalent zero mark).

¹⁾ Observe the explanation provided in Chapter "Function diagrams and parameters (Page 493)".

Step 3: Travel to reference point

Travel to the reference point is started when the drive has successfully synchronized to the reference zero mark (refer to step 2). Once the reference zero mark has been detected, the drive accelerates on-the-fly to the reference point approach velocity set in parameter p2611. The drive moves through the reference point offset (p2600), i.e. the distance between the zero mark and reference point.

If the axis has reached the reference point, then the actual position value and setpoint are set to the value specified using connector input p2598 (reference point coordinate) (as standard, connector input p2598 is connected with adjustable parameter p2599). The axis is then referenced and the status signal r2684.11 (reference point set) set.

Note

The velocity override is inoperative during this process.

If the braking distance is longer than the reference point offset or a direction reversal is required as a result of the selected reference point offset, then after detecting the reference zero mark, the drive initially brakes to standstill and then travels back.

Flying referencing

Inaccuracies in the actual value acquisition are compensated with flying referencing. This increases the load-side positioning accuracy.

The mode "flying referencing" (also known as post-referencing, positioning monitoring), which is selected using a "1" signal at binector input p2597 (select referencing type), can be used in every mode (jog, traversing block and direct setpoint specification for positioning/setting-up) and is superimposed on the currently active mode. Flying referencing can be selected both with incremental and absolute measuring systems.

With "flying referencing" during incremental positioning (relative) you can select whether the offset value is to be taken into account for the travel path or not (p2603).

The "flying referencing" is activated by a 0/1 edge at binector input p2595 (start referencing). The signal in binector input p2595 (start referencing) must be set during the entire referencing process otherwise the process is aborted.

Status bit r2684.1 (passive/flying referencing active) is linked with binector input p2509 (activate measurement probe evaluation). It activates measurement probe evaluation. Binector inputs p2510 (measurement probe selection) and p2511 (measurement probe edge evaluation) can be used to set which measurement probe (1 or 2) and which measurement edge (0/1 or 1/0) is to be used.

The probe pulse is used to supply connector input p2660 (referencing measured value) with the measured value via parameter r2523. The validity of the measurement is reported to binector input p2661 (measurement valid feedback) via r2526.2.

Note

The following must always apply to the "Flying referencing mode" windows:

p2602 (outer window) > p2601 (inner window).

You can obtain more information on the "Flying referencing" function in the SINAMICS S120/S150 List Manual in function diagram 3614.

The following then happens:

- If the drive has not yet been referenced, status bit r2684.11 (reference point set) is set to "1".
- If the drive has already been referenced, status bit r2684.11 (reference point set) is not reset when starting flying referencing.
- If the drive has already been referenced and the position difference is less than the inner window (p2601), the old actual position value is retained.
- If the drive has already been referenced and the position difference is more than the outer window (p2602), alarm A07489 (reference point offset outside window 2) is output and the status bit r2684.3 (pressure mark outside window 2) set. No offset to the actual position value is undertaken.
- If the drive has already been referenced and the position difference is more than the inner window (p2601) and less than the outer window (p2602), the actual position value is offset.

Note

On-the-fly referencing is superimposed on an active operating mode, it is therefore not an active mode.

In contrast to reference point approach, flying referencing can be carried out superimposed by the machine process.

As standard, for flying referencing, measuring probe evaluation is used; when enabled, the measuring probe is selected (p2510) and the edge evaluation (p2511) (in the factory setting, measuring probe 1 is always the measuring probe, flank evaluation in the factory setting is always the 0/1 edge).

Instructions for data set changeover

Using drive data set changeover (DDS), motor data sets (MDS, p0186) and encoder data sets (EDS, p0187 to p0189) can be changed over. The following table shows when the reference bit (r2684.11) or the status of the adjustment with absolute encoders (p2507) is reset.

In the following cases, when a DDS changeover takes place, the actual position value becomes invalid (p2521 = 0) and the reference point (r2684.11 = 0) is reset.

- The EDS that is effective for the position control changes.
- The encoder assignment changes (p2502).
- The mechanical relationships change (p2503...p2506)

With absolute encoders, the status of the adjustment (p2507) is also reset, if the same absolute encoder is selected for the position control although the mechanical relationships have changed (p2503 ... p2506).

In the operation state, a fault (F07494) is also output.

The following table contains a few examples for data set changeover. The initial data set is always DDS0.

Table 8-7 DDS changeover without load gear position tracking

DDS	p0186 (MDS)	p0187 (encoder_1)	p0188 (encoder_2)	p0189 (encoder_3)	Encoder for position control p2502	Mechanical conditions ⁴⁾ p2504/ p2505/ p2506 or p2503	Load gear position tracking	Changeover response
0	0	EDS0	EDS1	EDS2	Encoder_1	xxx	Deactivated	---
1	0	EDS0	EDS1	EDS2	Encoder_1	xxx	Deactivated	Changeover during pulse inhibit or operation has no effect
2	0	EDS0	EDS1	EDS2	Encoder_1	yyy	Deactivated	Pulse inhibit: Actual position value processing is newly initiated ¹⁾ and reference bit ²⁾ is reset. Operation: Fault is output. Actual position value processing is newly initiated ¹⁾ and reference bit ²⁾ is reset.
3	0	EDS0	EDS1	EDS2	Encoder_2	xxx	Deactivated	Pulse inhibit: Actual position value processing is newly initiated ¹⁾ and reference bit ³⁾ is reset. Operation: Fault is output. Actual position value conditioning is newly initiated ¹⁾ and reference bit ³⁾ is reset.
4	0	EDS0	EDS3	EDS2	Encoder_2	xxx	Deactivated	
5	1	EDS4	EDS1	EDS2	Encoder_1	xxx	Deactivated	
6	2	EDS5	EDS6	EDS7	Encoder_1	zzz	Deactivated	
7	3	EDS0	EDS1	EDS2	Encoder_1	xxx	Deactivated	MDS changeover alone during pulse inhibit or operation has no effect

¹⁾ "Is newly initiated" means: For absolute encoders, the absolute value is read out again and for incremental encoders a restart is performed as after a POWER ON.

²⁾ For incremental encoders r2684.11 ("Reference point set") is reset, and additionally for absolute encoders the status of adjustment (p2507).

³⁾ For incremental encoders r2684.11 ("Reference point set") is reset, and for absolute encoders the status of adjustment (p2507) is not reset in addition, because the encoder data set is different from the original.

⁴⁾ xxx, yyy, zzz: different mechanical conditions

8.8.4.1 Function diagrams and parameters

Function diagrams (see SINAMICS S120/S150 List Manual)

- 3612 EPOS - referencing / reference point approach mode (r0108.4 = 1)
(p2597 = 0 signal)
- 3614 EPOS - flying referencing mode (r0108.4 = 1)
(p2597 = 1 signal)

Overview of important parameters (see SINAMICS S120/S150 List Manual)

- p0494[0...n] Equivalent zero mark, input terminal¹⁾
- p0495 Equivalent zero mark, input terminal¹⁾
- p2596 BI: EPOS set reference point
- p2597 BI: EPOS referencing type selection
- p2598[0...3] CI: EPOS reference point coordinate, signal source
- p2599 CO: EPOS reference point coordinate value
- p2600 EPOS reference point approach, reference point offset

¹⁾ Parameter p0494 corresponds to parameter p0495 regarding its significance. In addition, parameter p0494 is dependent on an encoder data set; for example which can be used for the data set switchover for interchangeable machining heads.

8.8.5 Referencing with several zero marks per revolution

The drive detects several zero marks per revolution when using reduction gears or measuring gears. In this cases, an additional BERO signal allows the correct zero mark to be selected.

Example with a reduction gear

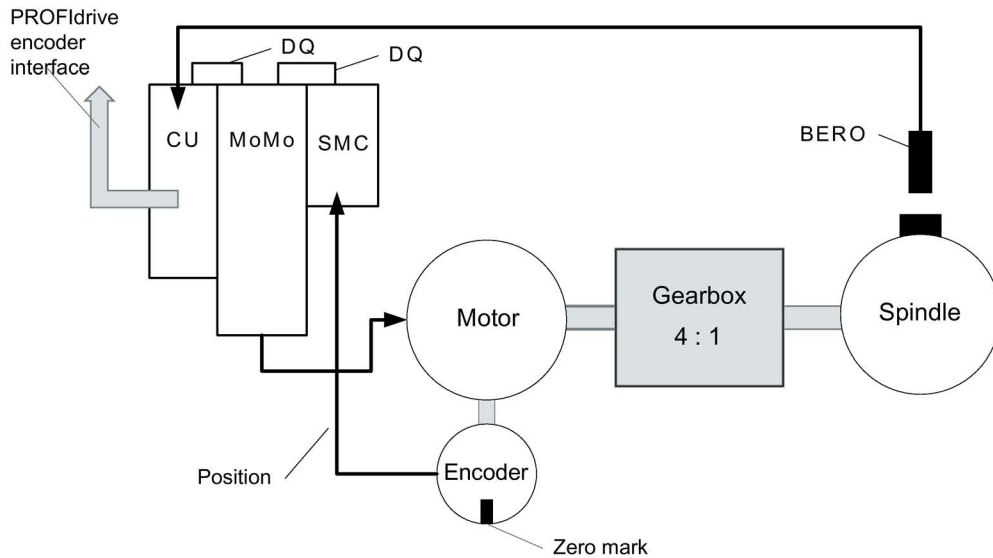

Figure 8-18 Design with a gear between the motor and spindle

The diagram shows an application example for referencing with several zero marks per revolution and selecting the correct zero mark using a BERO signal.

By using a reduction gear between the motor and the load (spindle), the drive detects several revolutions of the motor per mechanical revolution of the load - and therefore also several encoder zero marks.

The higher-level control/position control when referencing requires a unique reference between the encoder zero mark and the machine axis (load/spindle). This is the reason that the "correct" zero mark is selected using a BERO signal.

Example with a measuring gear

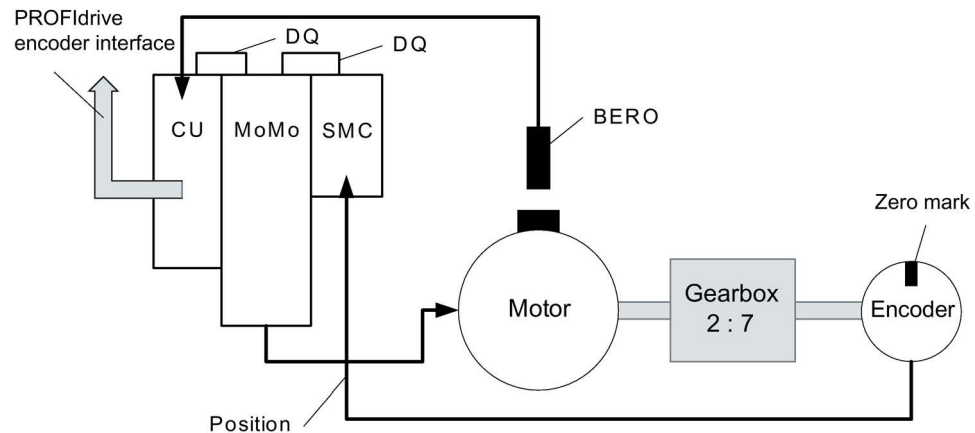

Figure 8-19 Measuring gear between the motor and encoder

The diagram shows an application example for using referencing with several zero marks per revolution with a measuring gear located between the motor/load and encoder.

As a result of the measuring gear, several encoder zero marks appear within one motor/load revolution. Using the BERO signal, also here, the correct zero mark for referencing can be selected from the several encoder zero marks.

Preconditions

- The position of the zero mark that has the shortest distance to the position when the BERO signal switches is to be determined.
- The appropriate mechanical preconditions must be fulfilled when mounting the BERO.
- Preferred mechanical configuration
The BERO signal covers the zero mark, as in this case, the zero mark selection is independent of the direction of rotation.
- In order to be able to precisely determine the position of the BERO (in relation to the reference position of the encoder) even at higher speeds, this must be connected to a fast Control Unit input.

Evaluating the BERO signal

You have the option of either evaluating the positive or negative signal edge of the BERO signal:

- Positive edge (factory setting)

For referencing with a positive edge evaluation of the BERO signal, the encoder interface supplies the position of that reference mark, which is directly detected after the positive edge of the BERO signal. If, mechanically, the BERO is sized in such a way that the BERO signal covers the entire width of the encoder zero mark, the required encoder zero mark will be reliably detected in both traversing directions.

- Negative edge

For referencing with a negative edge evaluation of the BERO signal, synchronization is realized to the next reference mark after leaving the BERO signal.

Setting referencing

Proceed as follows to parameterize referencing with several zero marks:

1. Using parameter p0493, define the fast digital input to which the BERO is connected.
2. Set the corresponding bit of parameter p0490 to 1.

The signal inversion means that the evaluation uses the negative edge of the BERO signal.

Referencing procedure

Referencing then proceeds as follows:

1. Via the PROFIdrive encoder interface, the Control Unit receives the request for a reference mark search.
2. Using the parameterization, the Control Unit determines the zero mark depending on the BERO signal.
3. The Control Unit provides the (possibly corrected) zero mark position as reference mark via the PROFIdrive encoder interface.

Note

At high speeds or if the distance between the BERO signal and the following zero mark is too low, then it is possible that the required, next zero mark is not detected, but instead, a subsequent one due to the computation time. Due to the known zero mark distance, in this particular case, the determined position is correspondingly corrected.

When using a measuring gear, the zero mark position depends on the motor revolution. In this case, a correction is also performed and for each motor revolution a reverse calculation is made back to the position of the zero mark with the shortest distance BERO signal ↔ zero mark.

Overview of important parameters (see SINAMICS S120/S150 List Manual)

- p0488 Probe 1, input terminal
- p0489 Probe 2, input terminal
- p0493 Zero mark selection, input terminal
- p0495 Equivalent zero mark, input terminal
- p0580 Probe, input terminal
- p0680[0...7] Central probe, input terminal
- p2517[0...2] LR direct probe 1
- p2518[0...2] LR direct probe 2

8.8.6 Safely referencing under EPOS

Basic positioning with safe referencing

Some safety functions (e.g. SLP, SP) require safe referencing. If EPOS is active at a drive, when referencing using EPOS, then the absolute position is also automatically transferred to the Safety Integrated functions.

The Safety Integrated functions only evaluate the absolute position if a safety function is parameterized, which requires an absolute value, e.g. SLP.

The following are examples for a load-side position calculation, depending on various encoder mounting versions and axis types.

Example 1:

Safety Integrated Extended functions monitor the rotating load. EPOS and Safety Integrated Extended functions use the same rotary encoder at the motor. The rotating load is coupled to the motor via a gear. The speed/position values of the spindle are calculated.

- p2506 = 360000 => a position of 360000LU (r2521) corresponds to 360° (r9708)
- p2506 = 10000 => a position of 10000LU (r2521) corresponds to 360° (r9708)

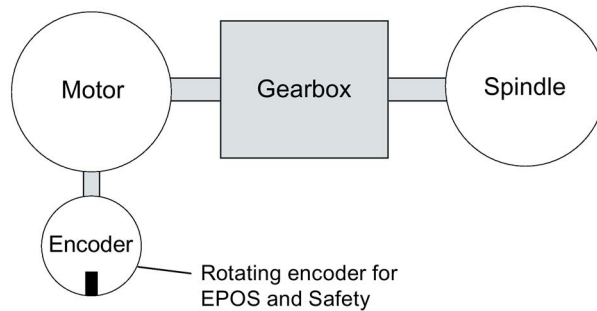

Figure 8-20 Example1: EPOS and safe referencing_rotating

The ratio for the gearbox used must be parameterized in p9521/p9522 for Safety Integrated Extended functions and in p2504/p2505 for EPOS. For a gearbox to convert 2 motor revolutions to 1 load revolution, set p9521 = 1, p9522 = 2, p2504 = 2 and p2505 = 1.

Example 2:

Safety Integrated Extended functions monitors the linear axis using the rotating motor encoder.

EPOS references using the linear scale.

- $p2503 = 100000 \Rightarrow$ a position of 100000LU (r2521) corresponds to 10 mm (r9708)
- $p2503 = 10000 \Rightarrow$ a position of 10000LU (r2521) corresponds to 10 mm (r9708)

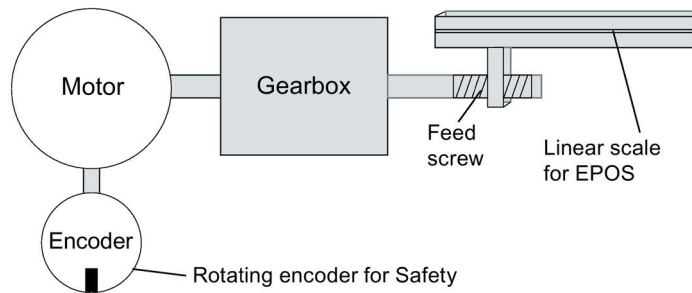

Figure 8-21 Example 2: EPOS and safe referencing_linear

Safety Integrated Extended function uses the rotating motor encoder. The gearbox is parameterized using p9521/p9522. The spindle pitch is parameterized in p9520. To calculate the load-side absolute position, EPOS directly uses the load-side linear scale. In this example, EPOS does not have to take into account the gearbox ratio and spindle pitch.

Example 3:

Safety Integrated Extended functions monitor the linear axis using the rotating motor encoder. EPOS referenced using the same rotary motor encoder.

- $p2506 = 10000$, $p9520 = 5 \text{ mm/revolution}$ => a position of 10000LU (r2521) corresponds to 5 mm (r9708)
- $p2506 = 5000$, $p9520 = 5 \text{ mm/revolution}$ => a position of 10000LU (r2521) corresponds to 10 mm (r9708)

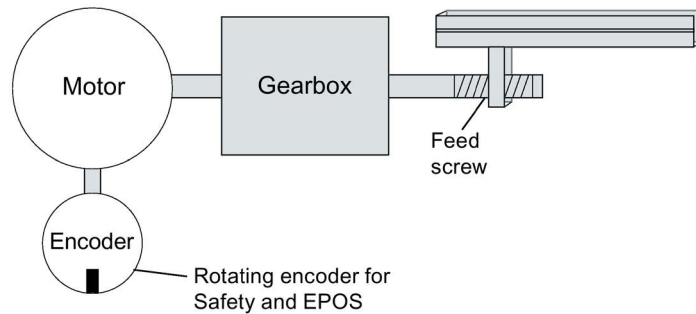

Figure 8-22 Example 3: EPOS and safe referencing_linear

Using the spindle pitch parameterized in parameter $p9520$, rotary motion is converted into linear motion. EPOS does not take into account spindle pitch. Instead, the LUs are defined in the number of load revolutions in $p2506$. The load revolutions refer to the movement of the ball screw, that is, the motion after the gearbox. The ratio for the gearbox used must be parameterized in $p9521/p9522$ for Safety Integrated Extended functions and in $p2504/p2505$ for EPOS. For a gearbox to convert from 4 motor revolutions to 3 load revolutions, set:

- $p9521 = 3$
- $p9522 = 4$
- $p2504 = 4$
- $p2505 = 3$

Flying referencing using Safety Integrated Extended functions

Flying referencing is frequently used to compensate for any inaccuracies in the actual value sensing, and therefore to optimize positioning accuracy on the load side. The Safety Integrated Extended functions have lower accuracy requirements than the control. For Safety Integrated Extended functions, cyclic adjustment is not necessary.

The initial activation signal initiates referencing. If, at the next switching signal, it is detected that the "referenced" state already exists, then no new reference position is transferred to Safety Integrated functions.

8.8.7 Traversing blocks

Up to 64 different traversing tasks can be saved. The maximum number is set using parameter p2615 (maximum number of traversing tasks). All parameters which describe a traversing task are effective during a block change, i.e. if:

- The appropriate traversing block number is selected using binector inputs p2625 to p2630 (block selection, bits 0...5) and started using the signal at binector input p2631 (BI: EPOS (activate traversing task)).
- A block change is made in a sequence of traversing tasks.
- An external block change p2632 "External block change" is triggered.

Parameter sets

Traversing blocks are parameterized using parameter sets that have a fixed structure:

- Traversing block number (p2616[0...63])
Every traversing block must be assigned a traversing block number (in STARTER "No."). The traversing blocks are executed in the sequence of the traversing block numbers. Numbers containing the value "-1" are ignored so that the space can be reserved for subsequent traversing blocks, for example.
- Task (p2621[0...63])
 - 1: POSITIONING
 - 2: FIXED ENDSTOP
 - 3: ENDLESS_POS
 - 4: ENDLESS_NEG
 - 5: WAIT
 - 6: GOTO
 - 7: SET_O
 - 8: RESET_O
 - 9: JERK
- Motion parameters
 - Target position or traversing distance (p2617[0...63])
 - Velocity (p2618[0...63])
 - Acceleration override (p2619[0...63])
 - Deceleration override (p2620[0...63])

- Task mode (p2623[0...63])

The execution of a traversing task can be influenced by parameter p2623 (task mode). This is automatically written by programming the traversing blocks in STARTER.
Value = 0000 cccc bbbb aaaa

 - aaaa: Identifiers

000x → hide/show block (x = 0: show, x = 1: hide);
A hidden block cannot be selected binary-coded via binector inputs p2625 to p2630. An alarm is output if you attempt to do so.
 - bbbb: Continuation condition

0000, END: 0/1 edge at p2631
0001, CONTINUE_WITH_STOP:
The exact position parameterized in the block is approached (brake to standstill and positioning window monitoring) before block processing can continue.
0010, CONTINUE_ON-THE-FLY:
The system switches to the next traversing block "on the fly" when the braking point for the current block is reached (if the direction needs to be changed, this does not occur until the drive stops within the positioning window).
0011, CONTINUE_EXTERNAL:
Same as "CONTINUE_ON-THE-FLY", except that an instant block change can be triggered up to the braking point by a 0/1 edge. The 0/1 edge can be triggered via the binector input p2633 when p2632 = 1 or via the measuring probe input p2661, which is connected to parameter r2526.2 of the "position control" function module, when p2632 = 0. Position detection via the probe can be used as an accurate starting position for relative positioning. If an external block change is not triggered, a block change is triggered at the braking point.
0100, CONTINUE_EXTERNAL_WAIT
Control signal "External block change" can be used to trigger a flying changeover to the next task at any time during the traveling phase. If "External block change" is not triggered, the axis remains in the parameterized target position until the signal is issued. The difference here is that with CONTINUE_EXTERNAL, a flying changeover is carried out at the braking point if "External block change" has not been triggered, while here the drive waits for the signal in the target position.
0101, CONTINUE_EXTERNAL_ALARM
This is the same as CONTINUE_EXTERNAL_WAIT, except that alarm A07463 "External traversing block change in traversing block x not requested" is output when "External block change" is not triggered by the time the drive comes to a standstill. The alarm can be converted to a fault with a stop response so that block processing can be canceled if the control signal is not issued.
 - cccc: positioning mode

The POSITION task (p2621 = 1) defines how the position specified in the traversing task is to be approached.
0000, ABSOLUTE: The position specified in p2617 is approached.
0001, RELATIVE: The axis is traveled along the value specified in p2617
0010, ABS_POS:
For rotary axes with modulo offset only. The position specified in p2617 is approached in a positive direction.
0011, ABS_NEG:
For rotary axes with modulo offset only. The position specified in p2617 is approached in a negative direction.
- Task parameter (command-dependent significance) (p2622[0...63])

Intermediate stop and reject traversing task

The intermediate stop is activated by a 0 signal at p2640. After activation, the system brakes with the parameterized deceleration value (p2620 or p2645).

The current traversing task can be rejected by a 0 signal at p2641. After activation, the system brakes with the maximum deceleration (p2573).

The "intermediate stop" and "reject traversing task" functions are only effective in "traversing blocks" and "direct setpoint specification / MDI" modes.

POSITIONING

The POSITIONING task initiates motion. The following parameters are evaluated:

- p2616[x] Block number
- p2617[x] Position
- p2618[x] Velocity
- p2619[x] Acceleration override
- p2620[x] Deceleration override
- p2623[x] Task mode

The task is executed until the target position is reached. If, when the task is activated, the drive is already located at the target position, then for the block change enable (CONTINUE_ON-THE-FLY or CONTINUE_EXTERNAL, the text task is selected in the same interpolation cycle. For CONTINUE_WITH_STOP, the next block is activated in the next interpolation cycle. CONTINUE_EXTERNAL_ALARM causes a message to be output immediately.

FIXED STOP

The FIXED STOP task triggers a traversing movement with reduced torque to fixed stop.

The following parameters are relevant:

- p2616[x] Block number
- p2617[x] Position
- p2618[x] Velocity
- p2619[x] Acceleration override
- p2620[x] Deceleration override
- p2623[x] Task mode
- p2622[x] Task parameter clamping torque [0.01 Nm] with rotary motors or clamping force in [1 N] with linear motors.

Possible continuation conditions include END, CONTINUE_WITH_STOP, CONTINUE_EXTERNAL, CONTINUE_EXTERNAL_WAIT.

ENDLESS POS, ENDLESS NEG

Using these tasks, the axis is accelerated to the specified velocity and is moved until:

- A software limit switch is reached.
- A STOP cam signal has been issued.
- The traversing range limit is reached.
- Motion is interrupted by the control signal "no intermediate stop / intermediate stop" (p2640).
- Motion is interrupted by the control signal "do not reject traversing task / reject traversing task" (p2641).
- An external block change is triggered (with the appropriate continuation condition).

The following parameters are relevant:

- p2616[x] Block number
- p2618[x] Velocity
- p2619[x] Acceleration override
- p2623[x] Task mode

All continuation conditions are possible.

JERK

Jerk limitation can be activated (command parameter = 1) or deactivated (task parameter = 0) by means of the JERK task. The signal at the binector input p2575 "Active jerk limitation" must be set to zero. The value parameterized in "jerk limit" p2574 is the jerk limit.

A precise stop is always carried out here regardless of the parameterized continuation condition of the task preceding the JERK task.

The following parameters are relevant:

- p2616[x] Block number
- p2622[x] Task parameter = 0 or 1

All continuation conditions are possible.

WAITING

The WAIT task can be used to set a waiting period which should expire before the following task is processed.

The following parameters are relevant:

- p2616[x] Block number
- p2622[x] Task parameter = delay time in milliseconds ≥ 0 ms
- p2623[x] Task mode

The delay time is entered in milliseconds - but is rounded-off to a multiple of the interpolator cycles p0115[5]. The minimum delay time is one interpolation cycle; this means that if a delay time is parameterized which is less than an interpolation cycle, then the system waits for one interpolation cycle.

Example:

Waiting time: 9 ms

Interpolation cycle: 4 ms

Active waiting time: 12 ms

Regardless of the parameterized continuation condition which is parameterized for the task that precedes the WAIT task, an exact stop is always executed before the waiting time expires. The WAIT task can be executed by an external block change.

Possible continuation conditions include END, CONTINUE_WITH_STOP, CONTINUE_EXTERNAL, CONTINUE_EXTERNAL_WAIT, and CONTINUE_EXTERNAL_ALARM. The fault message is triggered when "External block change" has still not been issued after the waiting time has elapsed.

GOTO

Using the GOTO task, jumps can be executed within a sequence of traversing tasks. The block number which is to be jumped to must be specified as task parameter. A continuation condition is not permissible. If there is a block with this number, then alarm A07468 (jump destination does not exist in traversing block x) is output and the block is designated as being inconsistent.

The following parameters are relevant:

- p2616[x] Block number
- p2622[x] Task parameter = Next traversing block number

Any two of the SET_O, RESET_O and GOTO tasks can be processed in an interpolation cycle and a subsequent POSITION and WAIT task can be started.

SET_O, RESET_O

The tasks SET_O and RESET_O allow up to two binary signals (output 1 or 2) to be simultaneously set or reset. The number of the output (1 or 2) is specified bit-coded in the task parameter.

The following parameters are relevant:

- p2616[x] Block number
- p2622[x] Task parameter = bit-coded output:
 - 0x1: Output 1
 - 0x2: Output 2
 - 0x3: Output 1 + 2

Possible continuation conditions are END, CONTINUE_ON-THE-FLY and CONTINUE_WITH_STOP, and CONTINUE_EXTERNAL_WAIT.

The binary signals (r2683.10 (output 1) or r2683.11 (output 2)) can be assigned to digital outputs. The assignment in STARTER is made using the "Configuration digital output" button.

Any two of the SET_O, RESET_O and GOTO tasks can be processed in an interpolation cycle and a subsequent POSITION and WAIT task can be started.

Function diagrams (see SINAMICS S120/S150 List Manual)

- 3616 EPOS - Traversing blocks mode (r0108.4 = 1)

Overview of important parameters (see SINAMICS S120/S150 List Manual)

- p2616[0...n] EPOS traversing block, block number
- p2617[0...n] EPOS traversing block, position
- p2618[0...n] EPOS traversing block, velocity
- p2619[0...n] EPOS traversing block, acceleration override
- p2620[0...n] EPOS traversing block, delay override
- p2621[0...n] EPOS traversing block, task
- p2622[0...n] EPOS traversing block, task parameter
- p2623[0...n] EPOS traversing block, task mode
- p2625...p2630 BI: EPOS block selection bits 0 ... 5

8.8.8 Travel to fixed stop

The "Travel to fixed stop" function can be used, for example, to traverse sleeves to a fixed stop against the workpiece with a predefined torque. In this way, the workpiece can be securely clamped. The clamping torque can be parameterized in the traversing task (p2622). An adjustable monitoring window for travel to fixed stop prevents the drive from traveling beyond the window if the fixed stop should break away.

In positioning mode, travel to fixed stop is started when a traversing block is processed with the FIXED STOP command. In this traversing block, in addition to the specification of the dynamic parameterized position, speed, acceleration override and delay override, the required clamping torque can be specified as task parameter p2622. From the start position onwards, the target position is approached with the parameterized speed. The fixed stop (the workpiece) must be between the start position and the braking point of the axis; that is, the target position is placed inside the workpiece. The preset torque limit is effective from the start, i.e. travel to fixed stop also occurs with a reduced torque. The preset acceleration and delay overrides and the current speed override are also effective. Dynamic following error monitoring (p2546) in the position controller is not effective when traveling to the fixed stop. As long as the drive travels to the fixed stop or is in fixed stop, the "Travel to fixed stop active" status bit r2683.14 is set.

Fixed stop is reached

As soon as the axis comes into contact with the mechanical fixed stop, the closed-loop control in the drive raises the torque so that the axis can move on. The torque increases up to the value specified in the task and then remains constant. The status bit r2683.12 "Fixed stop reached" is set depending on the binector input p2637 (Fixed stop reached):

- If the following error exceeds the value set in parameter p2634 (fixed stop: maximum following error) (p2637 = r2526.4) or
- If the status is set externally via the signal at binector input p2637 (fixed stop reached) (for p2637 ≠ r2526.4)

In travel to fixed stop, the clamping torque or clamping force in the traversing block is configured via the task parameter. It is specified in the units 0.01 Nm or 1 N (rotary / linear motor). The function module is coupled to the torque limit of the basic system via the connector output r2686[0] (torque limit upper) or r2686[1] (torque limit lower), which are connected to the connector input p1528 (torque limit upper scaling) or p1529 (torque limit lower scaling). The connector outputs r2686[0] (torque limit upper) and r2686[1] (torque limit lower) are set to 100% when fixed stop is not active. During active fixed stop, r2686[0] (torque limit upper) or r2686[1] (torque limit lower) are evaluated as a percentage of p1522/p1523 in such a way that the specified clamping torque or clamping force is limited.

When the fixed stop is acknowledged (p2637), the "Speed setpoint total" (r2562) is recorded, as long as the binector input p2553 (fixed stop reached message) is set. The speed control holds the setpoint torque due to the applied speed setpoint. The setpoint torque is output for diagnosis via the connector output r2687 (torque setpoint).

If the parameterized clamping torque is reached at the fixed stop, the status bit r2683.13 "Fixed stop clamping torque reached" is set.

Once the "Fixed stop reached" status has been detected, the traversing task "Travel to fixed stop" is ended. The program advances to the next block depending on the task parameterization. The drive remains in fixed stop until the next positioning task is processed or the system is switched to jog mode. The clamping torque is therefore also applied during subsequent waiting tasks. The continuation condition CONTINUE_EXTERNAL_WAIT can be used to specify that the drive must remain at the fixed stop until a step enabling signal is applied externally.

As long as the drive remains in fixed stop, the position setpoint is adjusted to the actual position value (position setpoint = actual position value). Fixed stop monitoring and controller enable are active.

Note

If the drive is in fixed stop, it can be referenced using the control signal "Set reference point".

If the axis leaves the position that it had at detection of the fixed stop by more than the selected monitoring window for the fixed stop p2635, then the status bit r2683.12 is reset. At the same time, the speed setpoint is set to 0, and fault F07484 "Fixed stop outside of the monitoring window" is triggered with the reaction OFF3 (quick stop). The monitoring window can be set using the parameter p2635 ("Fixed stop monitoring window"). It applies to both positive and negative traversing directions and must be selected such that it will only be triggered if the axis breaks away from the fixed stop.

Fixed stop is not reached

If the brake application point is reached without the "fixed stop reached" status being detected, then the fault F07485 "Fixed stop is not reached" is output with fault reaction OFF1, the torque limit is canceled and the drive cancels the traversing block.

Note

The fault can be changed into an alarm (see Section "Message configuration" in the SINAMICS S120 Commissioning Manual), which means that the drive program will advance to the next specified block.

The target point must be sufficiently far inside the workpiece.

Interruption to "Travel to fixed stop"

The "travel to fixed stop" traversing task can be interrupted and continued using the "intermediate stop" signal at the binector input p2640. The block is canceled using the binector input signal p2641 "Reject traversing task" or by removing the controller enable. In all of these cases, the drive is correspondingly braked. Measures are taken to prevent any risk of damage if the block is canceled when an axis has almost reached the fixed stop (setpoint already beyond the fixed stop, but still within the threshold for fixed stop detection). To do this, the setpoint is updated after standstill (position setpoint = actual position value). As soon as the fixed stop is reached, the drive remains in fixed stop even after cancelation. It can be moved away from the fixed stop using jog or by selecting a new traversing task.

Note

The fixed stop monitoring window (p2635) is only activated when the drive is at the fixed stop and remains active until the fixed stop is exited.

Vertical axis

Note

In servo control, a torque limit offset (p1532) can be entered for vertical axes (see also Section Vertical axis (Page 173)).

With asymmetrical torque limits p1522 and p1523, the self-weight is taken into account for travel to fixed stop in parameters r2686 and r2687.

If, for example, with a suspended load, p1522 is set to +1000 Nm and p1523 to -200 Nm, then a net weight of 400 Nm (p1522 - p1523) is assumed. If the clamping torque is now configured as 400 Nm, then r2686[0] is preset to 80%, r2686[1] to 0% and r2687 to 800 Nm when travel to fixed stop is activated.

Function diagrams (see SINAMICS S120/S150 List Manual)

- 3616 EPOS - Traversing blocks mode (r0108.4 = 1)
- 3617 EPOS - Travel to fixed stop (r0108.4 = 1)
- 4025 Position control - Dynamic following error monitoring, cam controllers (r0108.3 = 1)

Overview of important parameters (see SINAMICS S120/S150 List Manual)

- p1528[0...n] CI: Torque limit, upper/motoring, scaling
- p1529[0...n] CI: Torque limit, lower/regenerative scaling
- p1545[0...n] BI: Activate travel to fixed stop
- r2526.0...9 CO/BO: LR status word
- p2622[0...n] EPOS traversing block, task parameter
- p2634[0...n] EPOS fixed stop maximum permissible following error
- p2635 EPOS fixed stop monitoring window
- p2637 BI: EPOS fixed stop reached
- p2638 BI: EPOS fixed stop outside monitoring window
- r2683.0...14 CO/BO: EPOS status word 1
- r2686[0...1] CO: EPOS torque limit effective
- r2686[0...1] CO: EPOS force limiting active (for linear motors)

8.8.9 Direct setpoint input (MDI)

The "direct setpoint specification" function allows for positioning (absolute, relative) and setup (endless position-controlled) by means of direct setpoint specification (e.g. via the PLC using process data).

During traversing, the motion parameters can also be influenced (on-the-fly setpoint acceptance) and an on-the-fly change can be undertaken between the Setup and Positioning modes. The "direct setpoint specification" mode (MDI) can also be used if the axis is not referenced in the "setup" or "relative positioning" modes, which means that "flying referencing" (see the separate section), flying synchronization, and post-referencing are possible.

The "direct setpoint specification" function is activated by p2647 = 1. A distinction is made between two modes: "positioning" mode (p2653 = 0) and "setup" mode (p2653 = 1).

In "positioning" mode, the parameters (position, velocity, acceleration and deceleration) can be used to carry out absolute (p2648 = 1) or relative (p2648 = 0) positioning with the parameter p2690.

In the "setup" mode, using parameters (velocity, acceleration and deceleration) endless closed-loop position control behavior can be carried out.

It is possible to make a flying changeover between the two modes.

If continuous acceptance (p2649 = 1) is activated, changes to the MDI parameters are accepted immediately. Otherwise the values are only accepted when there is a positive edge at binector input p2650.

Note

Continuous acceptance p2649 = 1 can only be set with free telegram configuration p0922 = 999. No relative positioning is allowed with continuous acceptance.

The positioning direction can be specified using p2651 (positive direction specification) and p2652 (negative direction specification). If both inputs have the same status, the shortest distance is traveled during absolute positioning (p2648 = "1") of modulo axes (p2577 = "1").

To use the positioning function, the drive must be in the "Operation" state (r0002 = 0). The following options are available for starting positioning:

- p2649 is "1" and positive edge on p2647
- p2649 is "0" and p2647 is "1"
 - Positive edge on p2650 or
 - Positive edge on p2649

An overview of the setpoint transfer / direct setpoint specification can be found in the function diagram 3620 (see SINAMICS S120/S150 List Manual).

Features

- Select direct setpoint specification (p2647)
- Select positioning type (p2648)
- Direction selection (p2651, p2652)
- Setting-up (p2653)
- Fixed setpoints
 - CO: Position setpoint (p2690)
 - CO: Velocity setpoint (p2691)
 - CO: Acceleration override (p2692)
 - CO: Deceleration override (p2693)
- Connector inputs
 - CI: MDI position setpoint (p2642)
 - CI: MDI velocity setpoint (p2643)
 - CI: MDI acceleration override (p2644)
 - CI: MDI deceleration override (p2645)
 - CI: Velocity override (p2646)
- Accept (p2649, p2650)

MDI mode with the use of PROFIdrive telegram 110.

If the connector input p2654 is preset with a connector input $\neq 0$ (e.g. with PROFIdrive telegram 110 with r2059[11]), then it will internally manage the control signals "Select positioning type", "Positive direction selection" and "Negative direction selection". The following characteristics are evaluated from the value of the connector input:

- xx0x = absolute -> p2648
- xx1x = relative -> p2648
- xx2x = ABS_POS -> p2648, p2651
- xx3x = ABS_NEG -> p2648, p2652

Intermediate stop and reject traversing task

The intermediate stop is activated by a 0 signal at p2640. After activation, the system brakes with the parameterized deceleration value (p2620 or p2645).

The current traversing task can be rejected by a 0 signal at p2641. After activation, the system brakes with the maximum deceleration (p2573).

The "intermediate stop" and "reject traversing task" functions are only effective in "traversing blocks" and "direct setpoint specification / MDI" modes.

Function diagrams (see SINAMICS S120/S150 List Manual)

- 3618 EPOS - Direct setpoint specification / MDI mode, dynamic values (r0108.4 = 1)
- 3620 EPOS - Direct setpoint specification / MDI mode (r0108.4 = 1)

Overview of important parameters (see SINAMICS S120/S150 List Manual)

- p2577 BI: EPOS modulo offset activation
- p2642 CI: EPOS direct setpoint specification / MDI, position setpoint
- p2643 CI: EPOS direct setpoint specification / MDI, velocity setpoint
- p2644 CI: EPOS direct setpoint specification / MDI, acceleration override
- p2645 CI: EPOS direct setpoint specification / MDI, deceleration override
- p2648 BI: EPOS direct setpoint specification / MDI, positioning type
- p2649 BI: EPOS direct setpoint specification / MDI, acceptance method selection
- p2650 BI: EPOS direct setpoint specification / MDI, setpoint acceptance edge
- p2651 BI: EPOS direct setpoint specification / MDI, positive direction selection
- p2652 BI: EPOS direct setpoint specification / MDI, negative direction selection
- p2653 BI: EPOS direct setpoint specification / MDI, setup selection
- p2654 CI: EPOS direct setpoint specification / MDI, mode adaptation
- p2690 CO: EPOS position, fixed setpoint
- p2691 CO: EPOS velocity, fixed setpoint
- p2692 CO: EPOS acceleration override, fixed setpoint
- p2693 CO: EPOS delay override, fixed setpoint

8.8.10 Jog

Using parameter p2591 it is possible to change over between jog incremental and jog velocity.

The traversing distances p2587 and p2588 and velocities p2585 and p2586 are entered using the jog signals p2589 and p2590. The traversing distances are only effective for a "1" signal at p2591 (jog incremental). For p2591 = "0" then the axis moves to the start of the traversing range or to the end of the traversing range with the specified velocity.

An overview of the "Jog" function can be found in function diagram 3610 (see SINAMICS S120/S150 List Manual).

Features

- Jog signals (p2589, p2590)
- Velocity (p2585, p2586)
- Incremental (p2587, p2588, p2591)

Function diagrams (see SINAMICS S120/S150 List Manual)

- 3610 EPOS - Jog mode (r0108.4 = 1)

Overview of important parameters (see SINAMICS S120/S150 List Manual)

- p2585 EPOS jog 1 setpoint velocity
- p2586 EPOS jog 2 setpoint velocity
- p2587 EPOS jog 1 travel distance
- p2588 EPOS jog 2 travel distance
- p2589 BI: EPOS jog 1 signal source
- p2590 BI: EPOS jog 2 signal source
- p2591 BI: EPOS jog incremental

8.8.11 Status signals

The status signals relevant to positioning mode are described below.

Tracking mode active (r2683.0)

The "Follow-up active mode" status signal shows that follow-up mode has been activated which can be done by binector input p2655 (follow-up mode) or by a fault. In this status, the position setpoint follows the actual position value, i.e. position setpoint = actual position value.

Setpoint static (r2683.2)

The status signal "setpoint static" indicates that the setpoint velocity has a value of 0. The actual velocity can deviate from zero due to a following error. While the status word has a value of 0, a traversing task is being processed.

Traversing command active (r2684.15)

The status signal "traversing command active" indicates that a traversing command is active. A motion command should be understood to comprise all motions (including jog, setup etc.). Contrary to the status signal "setpoint static", the status signal remains active - e.g. if a traversing command was stopped by a velocity override or intermediate stop.

SW limit switch plus reached (r2683.7)

SW limit switch minus reached (r2683.6)

These status signals indicate that the parameterized negative p2578/p2580 or positive p2579/p2581 traversing range limit was reached or passed. If both status signals are 0, the drive is located within the traversing limits.

Stop cam minus active (r2684.13)

Stop cam plus active (r2684.14)

These status signals indicate that the STOP cam minus p2569 or STOP cam plus p2570 has been reached or passed. The signals are reset when the cams are left in the direction other than that in which they were approached.

Axis moves forwards (r2683.4)

Axis moves backwards (r2683.5)

Axis accelerates (r2684.4)

Drive decelerates (r2684.5)

Drive stationary (zero speed) (r2199.0)

These signals display the current motion status. If the actual absolute speed is less or equal to p2161, then the status signal "drive stationary" is set - otherwise it is deleted. The signals are appropriately set if jog mode, reference point approach or a traversing task is active.

Cam switching signal 1 (r2683.8) Cam switching signal 2 (r2683.9)

The electronic cam function can be implemented using these signals. Cam switching signal 1 is 0 if the actual position is greater than p2547 - otherwise 1. Cam switching signal 2 is 0 if the actual position is greater than p2548 - otherwise 1. This means that the signal is deleted if the drive is located behind (after) the cam switching position. The position controller initiates these signals.

Direct output 1 (r2683.10) Direct output 2 (r2683.11)

If a digital output is parameterized, the function "direct output 1" or "direct output 2", then it can be set by a corresponding command in the traversing task (SET_O) or reset (RESET_O).

Following error in tolerance (r2684.8)

When the axis is traversed, closed-loop position controlled, using a model, the permissible following error is determined from the instantaneous velocity and the selected Kv factor. Parameter p2546 defines a dynamic following error window that defines the permissible deviation from the calculated value. The status signal indicates as to whether the following error is within the window (status 1).

Target position reached (r2684.10)

The status signal "target position reached" indicates that the drive has reached its target position at the end of a traversing command. This signal is set as soon as the actual drive position is within the positioning window p2544 and is reset, if it leaves this window.

The status signal is not set, if

- Signal level 1 at binector input p2554 "signal traversing command active".
- Signal level 0 at binector input p2551 "signal setpoint static".

The status signal remains set, until

- Signal level 1 at binector input p2551 "signal setpoint static".

Reference point set (r2684.11)

The signal is set as soon as referencing has been successfully completed. It is deleted as soon as no reference is there or at the start of the reference point approach.

Acknowledgement, traversing block activated (r2684.12)

A positive edge is used to acknowledge that in the mode "traversing blocks" a new traversing task or setpoint was transferred (the same signal level as binector input p2631 activate traversing task). In the mode "direct setpoint input / MDI for setting-up/positioning" a positive edge is used to acknowledge that a new traversing task or setpoint was transferred (the same signal level as binector input p2650 "edge setpoint transfer", if the transfer type was selected using a signal edge (binector input p2649 "0" signal)).

Velocity limiting active (r2683.1)

If the actual setpoint velocity exceeds the maximum velocity p2571 - taking into account the velocity override - it is limited and the control signal is set.

8.9 Master/slave function for Active Infeed

8.9.1 Operating principle

This function allows drives to be operated with a redundant infeed. Redundancy can only be implemented in the components specified below, such as Line Modules, Motor Modules and Control Units. The function can be applied for the following applications:

- Hoisting gear that is to continue functioning in emergency mode (e.g. so that the load can still be placed down).
- Paper and steel works that require a line drive to continue operation at a reduced line velocity.
- Oil production platforms that must continue normal production even if one infeed fails (full redundancy).
- Expansion of output range for plants with infeeds of different dimensions.
- Infeed from line supplies/transformers with phase displacement and/or voltage difference to a common DC link.

This function requires each infeed to be served by a separate Control Unit. It also requires either a higher-level control system (e.g. SIMATIC S7) to transfer current setpoints using the PROFIBUS slave-to-slave communication capability or TM31 modules which transfer current setpoints in the form of analog signals. If the infeeds are appropriately configured, operation can continue even if an infeed has failed. The master is selected by the controller and operated under V_{dc} voltage control (parameter p3513 = 0) with current control. The slaves receive their setpoint directly from the master and are only operated under current control (parameter p3513 = 1).

Electrical isolation from the line with isolating transformers is necessary to prevent equalizing currents from flowing.

The infeed can be decoupled from the DC link by means of a DC breaker.

8.9.2 Basic structure

DRIVE-CLiQ can be used to connect an Active Line Module (ALM) to a Control Unit (CU) and Voltage Sensing Module (VSM) to create an infeed train. A Motor Module together with a Sensor Module Cabinet (SMC) or Sensor Module External (SME) forms a drive train. A Control Unit controls the complete drive system. If one of the modules develops a fault, only the affected train will fail. This failure can be signaled, e.g. via read parameter r0863.0, as a fault message to the higher-level controller. The fault is evaluated in the user program of the higher-level controller, which sends corresponding signals to the other infeeds. If a higher-level controller is not used, the fault can be evaluated by means of DCCs in the Active Line Modules.

All the other trains remain fully functional, which means that they can continue operating normally.

Features

- The "master/slave" function only works in conjunction with Active Line Modules.
- One Active Line Module is the master and up to three others are slaves.
- If the master fails, a slave ALM takes on the role of the master.
- The redundant infeeds can continue functioning normally even if one infeed train has failed.
- Electrical isolation between the infeed trains is needed on the line side to prevent circulating currents caused by non-synchronous pulsing patterns.
- The entire infeed system supplies a joint DC busbar (DC link).
- Since the Active Line Module cannot detect whether the DC link is disconnected or a DC-link fuse has blown, an additional circuit to monitor these states must be installed (DC breaker checkback function and fuse signaling contacts).
- The higher-level controller communicates with the CUs and Active Line Modules via PROFIBUS/PROFINET or analog data. If a higher-level controller is not to be used, the control signals must be hard-wired (e.g. via TM31).
- Infeed trains with different outputs can be combined.

Topology

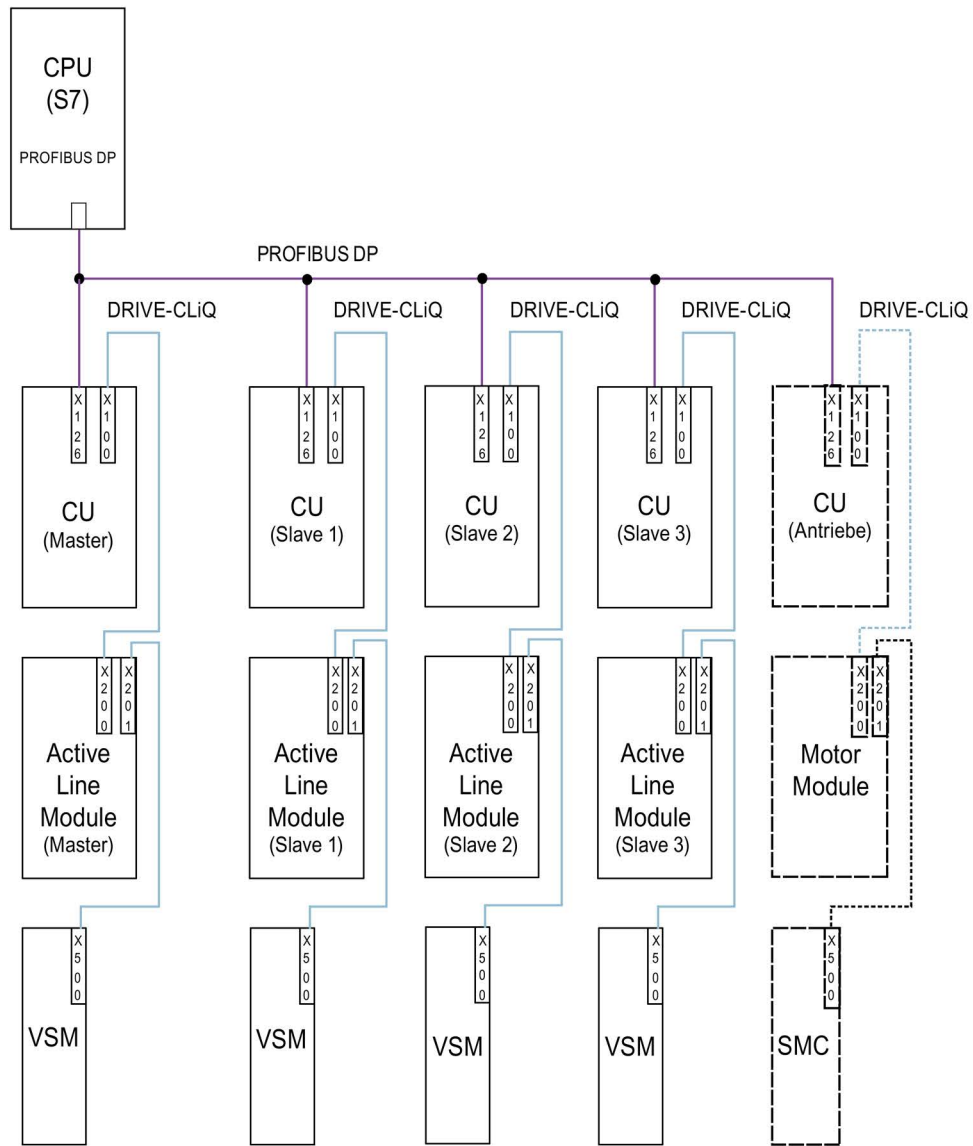

Figure 8-23 Topology structure and communications network based on PROFIBUS for master/slave operation with redundant infeeds (four infeed trains)

Master/slave operation can be implemented for a maximum of four Active Line Modules.

Electrical isolation of infeeds

To successfully implement the structure, a means of electrically isolating the infeeds from the line supply is required in addition to the SINAMICS components. This is to prevent circulating currents from developing if the pulse patterns of the Active Line Modules are not synchronized.

Two solutions are possible for the electrical isolation:

- Using an isolating transformer for each slave infeed train. The primary side of the transformer is to be connected to the grounded or ungrounded line transformer. The secondary side must never be grounded.
- Using a three-winding transformer for the master and slave infeeds. In this case, only the neutral point of one winding may be grounded to prevent further electrical coupling via ground.

Whichever solution is chosen, it must be noted that a separate transformer must be used for each Active Line Module (slaves 1 to 3).

DC breaker

Note

When an infeed develops a fault it is disconnected on the line side by the line contactor, on the DC-link side, using a DC breaker. Infeeds must not be switched in to a charged DC link. The DC link must be discharged before another infeed train can be switched in.

An infeed may only be connected to a charged DC link if a DC breaker with pre-charging branch is installed.

8.9.3 Types of communication

To implement master/slave operation, the CUs must be able to communicate with one another. The master passes the active current setpoint to the slaves. To optimize V_{dc} control (DC-link voltage), the dead times during communication must be kept to a minimum.

PROFIBUS slave-to-slave communication

The data is exchanged directly between the CUs without passing via the DP master. A PROFIBUS master (higher-level controller) is required to act as a "clock generator" (e.g. an S7-CPU). The minimum PROFIBUS cycle time that can be set depends on the PROFIBUS master specifications.

Isochronous mode must be set for PROFIBUS. The PROFIBUS cycle time must not exceed 2 ms otherwise the closed-loop control may start to oscillate.

In order to ensure that other infeeds do not switch to fault status when one CU fails, the fault message F01946 "Link to Publisher disconnected" must be deactivated.

The number "1946" can be set in one of the parameters p2101[0..19] and p2101[x] set to "0" in order to block fault message F01946. This means that the drive will not shut down when one slave-to-slave communication node fails.

In a master/slave infeed, a common current controller cycle is essential, particularly when infeeds with different outputs are used. If the number of PROFIBUS nodes or drives increases, this can affect the bus cycle or current controller sampling time.

Communication using an analog setpoint

The analog setpoint between the CUs with Terminal Module 31 (TM31) can also be used as an alternative to bus communication. The factory setting for the sampling time of analog inputs and/or outputs is 4 ms (TM31 inputs/outputs sampling time p4099[1/2]). The sampling times must be an integer multiple of the basic sampling times (r0110). The lowest common denominator of the current controller cycle for the integrated infeeds must be selected to implement the "master/slave" function. The sampling time of the analog inputs/outputs should be set to the same value as the current controller cycle (e.g. 250 μ s). The slave can then use the analog setpoint every second current controller cycle. The dead time is then one cycle.

The advantages of this variant is that the communication system can be configured to be independent of bus and master.

Disadvantages are the additional hardware wiring and the necessity to use one TM31 per CU. This communication method is also more susceptible to EMC-related problems. It is not absolutely essential to use a higher-level controller (e.g. SIMATIC S7) for this system. Control functions can also be implemented using DCCs in individual CUs.

8.9.4 Description of functions

The "Master/slave" function module is not implemented in the higher-level controller, but directly in the firmware of the CUs and infeeds. It is signaled by $r0108.19 = 1$ (option "Master/slave" for infeeds selected in STARTER).

The V_{dc} closed-loop control band and current setpoint via multiplexers of the Active Line Module control are implemented in the function module.

All infeeds must be parameterized in such a way that they are fully functional as both a master and slave. The infeeds can be switched between master and slave role during operation. Switchover is handled by a higher-level controller according to the setting in parameter p3513. A master is configured to operate with V_{dc} control (p3513 = 0) and current control, while the slaves operate only with current control (p3513 = 1). The setpoint input of the active current $I_{active(set)}$ is transferred from the master to the slaves via the communication links between the Control Units.

If the Active Line Module is used for reactive power compensation with external reactive current setpoint, then the reactive current setpoint must also be wired for the slave. The master-to-slave setpoint specifies only the active current.

When Active Line Modules have been deactivated, make sure that the maximum DC-link capacitance $C_{DC\ link}$ for the remaining Active Line Modules is not exceeded during the switch-on procedure (danger of overloading the pre-charging resistors).

Parameter p3422 ($C_{DC\ link}$ capacitance) can be changed in operation. This means that the closed-loop control can be directly adjusted via this parameter when the master/slave configuration changes, instead of changing the proportional gain of the $V_{DC\ link}$ controller (p3560). When parameter p3422 changes, parameter p3560 is recomputed automatically by the firmware.

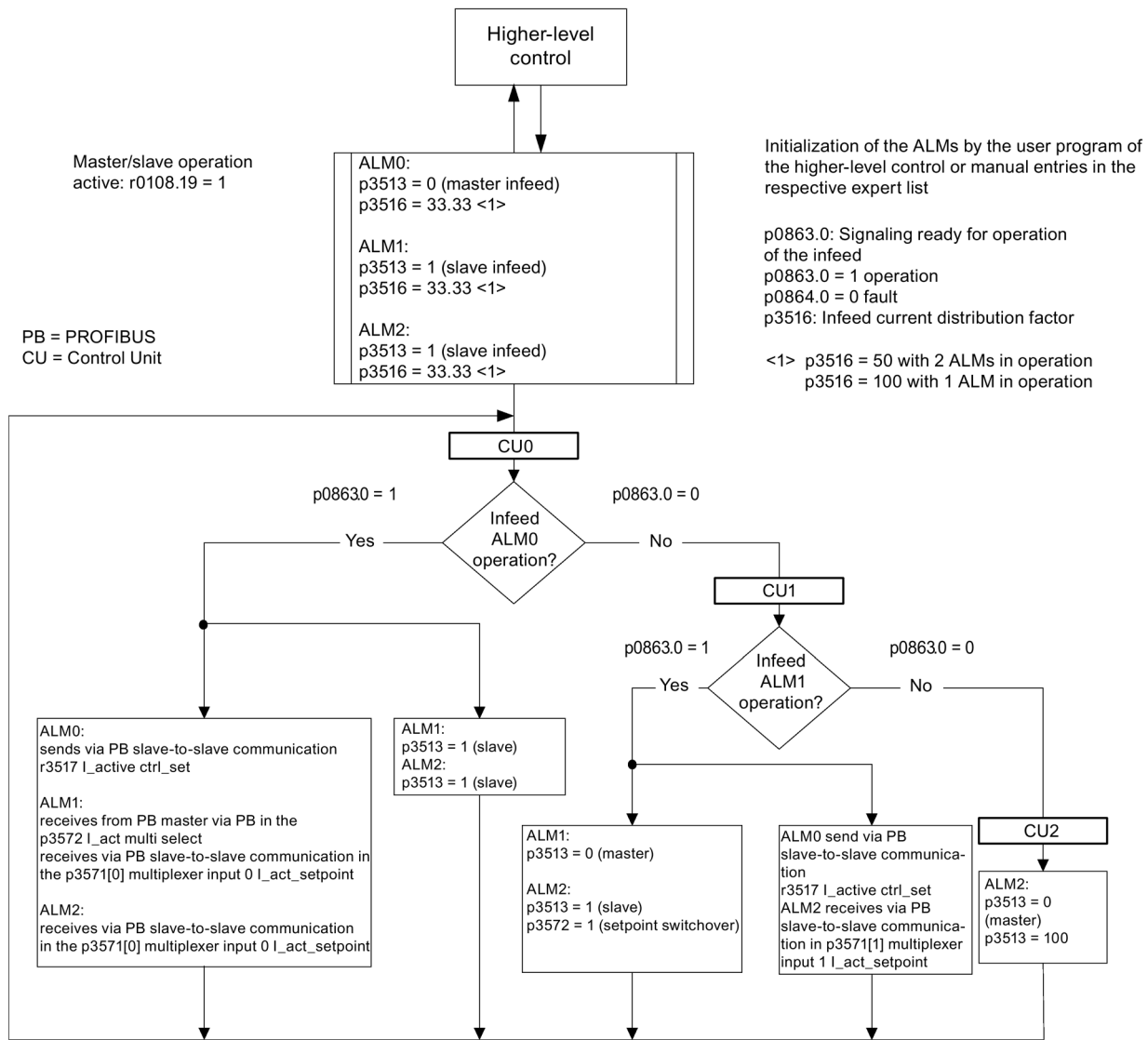

Figure 8-24 Structogram of master/slave operation, three identical Active Line Modules (ALMs) of identical output rating, PROFIBUS communication system

Function diagrams

The function of the "Master/slave infeeds" function module is shown in function diagrams 8940 and 8948 (see SINAMICS S120/S150 List Manual).

Explanations for the function diagrams

- **Current setpoint interconnection**

Parameter p3570 is used to connect the setpoint for the closed-loop current control (active current setpoint from the master). Using parameter p3513, which can be changed in the "ready for operation" state, it is possible to switch between master (V_{dc} control, parameter p3513 = 0) and slave (current control, parameter p3513 = 1) from the higher-level control system.

- **Selection of the current setpoint**

The current setpoint can be selected by means of a control word (XCS) (p3572) using a multiplexer with four inputs (X0 ... X3) (p3571.0 ... p3571.3). This means that the current setpoint of the new master can be selected when the old master has failed.

- **Selection of the current distribution factor**

To prevent a reduction in control dynamics of the DC-link voltage controller for non-symmetrical loads, this current distribution factor must be updated immediately when an infeed fails or is activated.

The current distribution factor is calculated from the number of active infeeds and their rated data. The sum of the current distribution factors of all active infeeds must always equal 100%.

The current distribution factor can be selected by means of a control word (XCS) (p3577) using a multiplexer with six inputs (X0 ... X5) (p3576.0...5).

Alternatively, a new current distribution factor can be calculated in the higher-level controller, sent via cyclic PROFIBUS PZD telegrams and interconnected directly to the connector input "Infeed: additional current distribution factor" (p3579).

A further alternative is to update the current distribution factor via an acyclic PROFIBUS parameter write order of p3516. This produces dead times however.

For alternatives without multiplexer, this can be used for a different function.

- **V_{dc} control band**

The V_{dc} limits can be violated in master/slave operation if the DC-link load changes abruptly (e.g. load surges or emergency stop). For this reason, the DC-link voltage is monitored on the basis of a V_{dc} control band. The V_{dc} control band defines a specific voltage range with hysteresis - set in parameter p3574.0/1 (upper/lower limit V_{dc} voltage band) and p3574.2/3 (hysteresis upper/lower voltage limit). A signal is generated if the DC-link voltage leaves this voltage range. By evaluating this signal, the slave is changed over from closed-loop current to closed-loop voltage control. When the DC-link voltage returns to within the control band, the slave is switched back to closed-loop current control. The V_{dc} control operates permanently in "standby mode" so that it can be re-activated when necessary.

8.9.5 Commissioning

Line supply and DC link identification

Before the "Master/slave" operation option is enabled in STARTER, the line supply and DC link identification (see Section Line supply and DC link identification (Page 31)) must be executed during commissioning for each infeed line.

Please follow the instructions given in the SINAMICS S120 Commissioning Manual for the commissioning of infeeds.

Once each individual infeed has been identified, the correct inductance for current control and the DC link capacitance for voltage control are set.

If a DC breaker for isolating the infeed from the DC link is installed, DC link identification must be performed again for all active infeeds after one has been disconnected, as it is necessary to acquire the DC link capacitance again. If the DC link capacitance is not adapted in this way, then the change in capacitance will affect the dynamic response of the V_{dc} control.

Note

Aligning the setpoints of the DC link voltage

The setpoints of the DC link voltage V_{dc} from p3510 of the master and the slaves must be set to the same values to ensure that the V_{dc} tolerance bandwidth monitoring functions correctly.

Activation of the master/slave function

The "Master/slave" function is activated with the checkbox/option "Master/Slave" in the STARTER wizard for the relevant infeed. Parameter r0108.19 can be used to scan for an active function module in the CU or the Active Line Modules (r0108.19 = 1). All other required parameters are set via the corresponding expert lists for the relevant infeed.

Note

The bus cycle time for Active Line Modules operating in master-slave operation must not exceed 2 ms. If the bus cycle time is higher, then the dynamic response (p3560) must be significantly reduced. This means that load surges can no longer be corrected properly.

Increasing the bus cycle time can cause the DC link voltage to oscillate, an effect which can sometimes be managed by reducing the dynamic response (p3560). The system cannot be guaranteed to function reliably with bus cycle times of > 2 ms.

The V_{dc} setpoint in p3510 must be set high enough to prevent the standby controller from responding to line overvoltage (the response threshold of 97% can be increased if necessary, but current and voltage harmonics will develop if the setting causes overcontrol).

In any case, the tolerance band must be set wide enough that it will not be violated should the control factor reserve controller still respond because the measures described above have not been implemented.

Master/slave switchover

If a power unit fails during operation, the higher-level controller can switch each infeed line from current control (slave operation) to DC link voltage control (master operation) and vice versa (parameter setting for master: p3513= 0, for slave: p3513 = 1).

Switching an ALM to an operational system

In an operational master-slave group, an ALM must first be switched in as a slave.

Shutting down an ALM from an operating group

Shutting down an ALM from the group should be realized in the slave state and with OFF2 (pulse inhibit). If a master fails with a fault (OFF2 response, pulse inhibit), one of the slaves must be immediately switched as master.

Two masters must not be operated simultaneously in the infeed group.

8.9.6 Function diagrams and parameters

Function diagrams (see SINAMICS S120/S150 List Manual)

- 8940 Active Infeed - Controller modulation depth reserve / controller DC link voltage (p3400.0 = 0)
- 8948 Active Infeed - Master/slave (r0108.19 = 1)

Overview of important parameters (see SINAMICS S120/S150 List Manual)

- p3513 BI: Voltage-controlled operation disable
- p3516 Infeed current distribution factor
- p3570 CI: Master/slave active current setpoint
- p3571[0...3] CI: Master/slave active current setpoint multiplexer input
- p3572 CI: Master/slave active current setpoint multiplexer selection
- r3573 CO: Master/slave active current setpoint multiplexer output
- p3574[0...3] Master/slave DC link voltage monitoring
- r3575.0...2 BO: Master/slave DC link voltage monitoring status
- p3576[0...5] Master/slave current distribution factor multiplex input
- p3577 CI: Master/slave current distribution factor multiplex selection
- r3578 CO: Master/slave current distribution factor multiplex output
- p3579 CI: Master/slave current distribution factor

8.10 Parallel connection of power units

In order to extend the power range, SINAMICS S120 supports the parallel connection of identical power units such as Line Modules and/or Motor Modules. The prerequisites for connecting power units in parallel are as follows:

- Same type
- Same type rating
- Same rated voltage
- Same firmware version
- Chassis or cabinet format
- The Motor Modules must be operated in vector control

It makes sense to connect Line Modules and Motor Modules in parallel for the following reasons:

- To boost the converter output if it is not technically or economically feasible to achieve the required power by any other means.
- To increase the availability, for example, to maintain emergency operation (possibly also at a lower rating), if a power unit fails.

Parallel operation is not released under the following conditions:

- Combining different types of Infeed Module within the same parallel connection (e.g. Basic Line Modules with Smart Line Modules or Basic Line Modules with Active Line Modules).
- Motor Modules in servo control
- Infeed Modules and Motor Modules in the booksize and blocksize formats

Features

The main features of parallel connection are:

- Parallel connection of up to four Motor Modules on one motor
 - Parallel connection of multiple Motor Modules on one motor with separate winding systems (p7003 = 1).

Note

Motors with separate winding systems are recommended.

- Parallel connection of multiple Motor Modules on one motor with a single winding system (p7003 = 0) is possible.

Note

Additional information and instructions in the SINAMICS S120 Chassis Power Units Manual must be carefully taken into consideration.

- Parallel connection of up to four power units on the infeed side (closed/open loop).

- A Control Unit, which controls and monitors power units on the line and motor sides connected in parallel, can control an additional drive, e.g. an auxiliary drive (see Section Additional drive in addition to the parallel connection (Page 537)).
- Parallel-connected power units must be connected to the same Control Unit.
- A Control Unit CU320-2 can simultaneously actuate a maximum of one parallel connection on the line side and one parallel connection on the motor side.
- Components at the line and motor sides for decoupling the parallel-connected power units and for ensuring symmetrical current distribution are recommended.
- Simple commissioning, because no special parameterization is necessary.
- Individual power units can be parameterized and diagnosed (troubleshooting) with p7000 ff.

The following modules can be connected in parallel:

- Basic Line Modules (BLM), 6-pulse and 12-pulse (each with the associated line reactors)
- Smart Line Modules (SLM), 6-pulse and 12-pulse (each with the associated line reactors)
- Active Line Modules (ALM), 6-pulse and 12-pulse (each with the associated Active Interface Modules)
- Motor Modules (in vector control mode)

Note**Deactivate edge modulation**

With a chassis parallel connection and motor with winding systems offset by 30 degrees (p7003 = 2), the converter can fail with activated edge modulation.

In this case, deactivate the edge modulation (p1802 ≤ 4).

Note**Exceptions for combined operation of Line Modules**

Smart Line Modules may be operated together with Basic Line Modules whose last digit of the Article number is a "3" (Chassis) or a "2" (Cabinet) with one or several CUs if precisely defined preconditions and the information in the Configuration Manual are maintained. You can find this information in the "SINAMICS - Low Voltage Configuration Manual (<http://www.automation.siemens.com/mcms/infocenter/dokumentcenter/ld/Documentsu20Catalogs/lv-umrichter/sinamics-engineering-manual-lv-en.pdf>)".

A slight reduction of the rated current must be considered for parallel connection of power units. The reduction of the rated current (derating) of a power unit for parallel connection is:

- 7.5% for parallel connections of SINAMICS S120 Basic Line Modules and SINAMICS S120 Smart Line Modules when neither module is equipped with a current compensation control.
- 5.0% for parallel connections of SINAMICS S120 Active Line Modules and SINAMICS S120 Motor Modules when each module operates with a current compensation control.

8.10.1 Applications of parallel connections

Power units can be connected in parallel (infeeds) in the following cases:

Version	Condition
6-pulse circuit	The modules connected in parallel are supplied from a two-winding transformer.
12-pulse circuit	The modules connected in parallel are supplied via a three-winding transformer, whose secondary windings supply voltages with a phase shift of 30°.

The following diagram is an overview of the module variants discussed in this section for inclusion in power unit parallel connections.

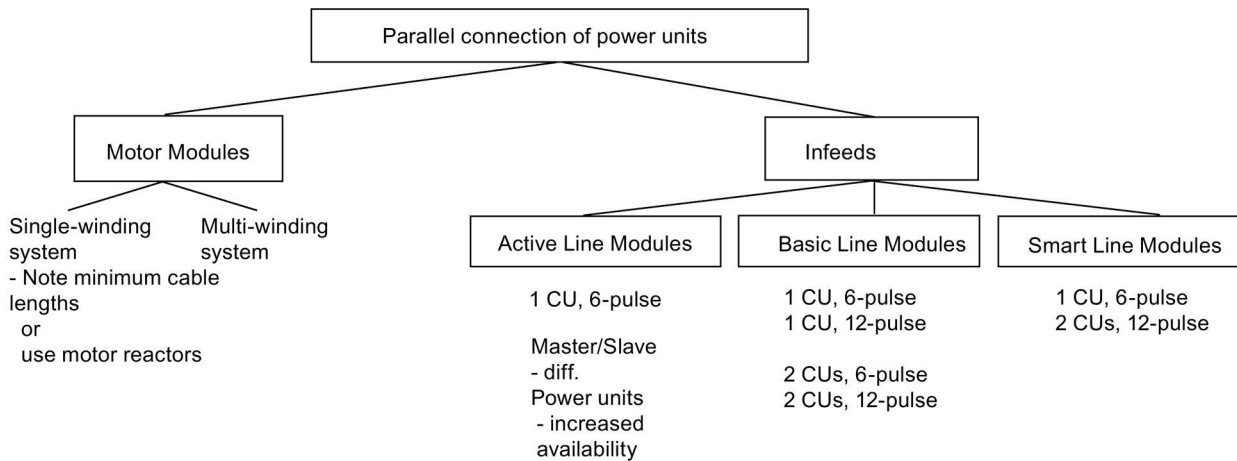

Figure 8-25 Parallel connection of power units - overview

Note

Additional information on parallel power unit connections, particularly with regard to their configuration, can be found in the "SINAMICS Low Voltage Configuration Manual (<http://www.automation.siemens.com/mcems/infocenter/dokumentencenter/ld/Documentsu20Catalogs/lv-umrichter/sinamics-engineering-manual-lv-en.pdf>)".

Infeed concepts - parallel (one CU) and redundant parallel (two CUs)

Some applications require redundant infeeds for a DC line-up. This requirement can be fulfilled through the implementation of multiple, independent infeeds which are connected in parallel to the DC line-up. Depending on how the drive is dimensioned, the DC line-up can continue operating at between 50% to 100% output when one infeed fails. With the redundant variant of the infeed parallel connection, each infeed is controlled by a separate Control Unit and is thus completely independent. With the non-redundant variant, a single Control Unit generally controls all parallel-connected power units which then, from a practical viewpoint, function like a single, high-output infeed.

The type of circuit required depends on whether the redundancy requirement applies only to the infeed itself or also includes the supply-side transformers or the supply systems (see "SINAMICS Low Voltage Configuration Manual (<http://www.automation.siemens.com/mcms/infocenter/dokumentcenter/ld/Documentsu20Catalogs/lv-umrichter/sinamics-engineering-manual-lv-en.pdf>)").

6-pulse infeed

With a 6-pulse infeed, the two redundant infeeds with the same power rating are supplied from a line supply via a two-winding transformer. As both infeeds are supplied with exactly the same line voltage, the current distribution is largely symmetrical in normal operation, even with uncontrolled infeeds. The infeeds can thus be dimensioned such that, taking into account a minor current derating factor, each can carry 50% of the total current. However, if one infeed fails, only half the output remains available. If the full output needs to be available when one infeed fails, then each infeed must be dimensioned to carry the full current.

12-pulse infeed

For a 12-pulse infeed, the two redundant infeeds with the same power rating are supplied from a line supply via a three-winding transformer. Depending on the transformer design, the line-side voltages of the two infeeds will include minor tolerances of between about 0.5% to 1%. These can cause slightly asymmetrical current distribution in normal operation when uncontrolled infeeds are used and current derating factors must be applied accordingly. If the full output needs to be available when one infeed fails, then each infeed must be dimensioned to carry the full current.

6-pulse, 12-pulse infeed

When separate Control Units are used, pre-charging may not be synchronized accurately enough, i.e. a converter system must be able to pre-charge the total capacity of the drive line-up. Pre-charging power for the DC link in parallel operation must be dimensioned so that the capacitance of the DC link can be fully charged by a single converter system. Otherwise a separate pre-charging device must be provided.

Configuring a parallel connection

Additional information on configuring parallel power units connections can be found in the "SINAMICS Low Voltage Configuration Manual (<http://www.automation.siemens.com/mcms/infocenter/dokumentcenter/ld/Documentsu20Catalogs/lv-umrichter/sinamics-engineering-manual-lv-en.pdf>)".

8.10.1.1 Parallel connection of Basic Line Modules

Features of Basic Line Modules:

- The DC-link voltage is greater than the rms value of the line rated voltage by a factor of 1.35.
- They are used in cases where regenerative feedback capability is not required.
- If regenerative operating states occur in the drive line-up, Braking Modules that convert the excess energy to heat in braking resistors must be used.

Basic Line Modules in chassis format are available for the following voltages and power ratings:

Table 8- 8 Basic Line Modules

Line supply voltage	Rated power
380 to 480 V 3 phase AC	200 ... 710 kW
500 to 690 V 3-phase AC	250 ... 1100 kW

The following rules must be observed when connecting Basic Line Modules in parallel:

- Up to four identical Basic Line Modules can be connected in parallel.
- A common Control Unit must always be used to implement the parallel connection.
- Special Line Connection Modules are available for the parallel connection.
- With multiple infeeds, power must be supplied to the systems from a common infeed point (i.e. the modules cannot be operated on different line supplies).
- A current reduction (derating) of 7.5% must be taken into consideration, regardless of the number of modules connected in parallel.

As Basic Line Modules have no current compensation control, the three-winding transformer, power cabling and line reactors must meet the following requirements in order to provide a balanced current:

- Three-winding transformer must be symmetrical, recommended vector groups Dy5d0 or Dy11d0.
- Relative short-circuit voltage of three-winding transformer $u_k \geq 4\%$.
- Difference between relative short-circuit voltages of secondary windings $\Delta u_k \leq 5\%$.
- Difference between no-load voltages of secondary windings $\Delta U \leq 0.5\%$.
- Use of symmetrical power cabling between the transformer and the Basic Line Modules (cables of identical type with the same cross-section and length)
- Using line reactors that match the Basic Line Modules

Line reactors can be omitted if a double-tier transformer is used and only one Basic Line Module is connected to each secondary winding of the transformer.

A double-tier transformer is generally the only means of meeting the requirements of a three-winding transformer for this application. Line reactors must always be installed if other types of three-winding transformer are used. Alternative solutions for obtaining a phase displacement of 30° , such as two separate transformers with different vector groups, cannot be used due to the inadmissibly high tolerances involved.

6-pulse parallel connection of Basic Line Modules

With the 6-pulse parallel connection, up to four Basic Line Modules are supplied by a common two-winding transformer on the line side and controlled by a common Control Unit.

12-pulse parallel connection of Basic Line Modules

For 12-pulse parallel connections, up to four Basic Line Modules are supplied by a three-winding transformer on the line side. In this case, an even number of modules, i.e. two or four, must be divided between the two secondary windings. The Basic Line Modules of both subsystems are controlled by a common Control Unit - even though the input voltages are 30° out of phase.

There is also the redundant version with which two BLMs in each case are controlled by one Control Unit.

If several Motor Modules are supplied from a non-regenerative infeed unit (e.g. a Basic Line Module), or for power failure or overload (for SLM/ALM), the Vdc_max control may only be activated for a Motor Module whose drive should have a high moment of inertia.

For the other Motor Modules this function must be disabled or monitoring must be set.

If the Vdc_max control is active for several Motor Modules, then for an unfavorable parameterization, the controllers can mutually influence one another negatively. The drives can become unstable, individual drives can unintentionally accelerate.

Remedial measures:

- Activating the Vdc_max control:
 - Vector control: p1240 = 1 (factory setting)
 - Servo control: p1240 = 1
 - U/f control: p1280 = 1 (factory setting)
- Inhibiting the Vdc_max control:
 - Vector control: p1240 = 0
 - Servo control: p1240 = 0 (factory setting)
 - U/f control: p1280 = 0
- Activating the Vdc_max monitoring function
 - Vector control: p1240 = 4 or 6
 - Servo control: p1240 = 4 or 6
 - U/f control: p1280 = 4 or 6

WARNING

Danger to life as a result of unplanned motion of individual drives

If several Motor Modules are supplied from one infeed unit, then if the Vdc_max control is incorrectly parameterized, individual drives can accelerate in an uncontrolled fashion - which can lead to death or severe injury.

- Only activate the Vdc_max control for the Motor Module whose drive has the highest moment of inertia.
- Inhibit this function for all other Motor Modules, or set this function to monitoring only.

8.10.1.2 Parallel connection of Smart Line Modules

Smart Line Modules are infeed/regenerative feedback units. Like the Basic Line Modules, they supply energy to the connected Motor Modules, but unlike the Basic Line Module, they are capable of feeding back regenerative energy to the line supply.

The DC-link voltage is greater than the rms value of the line rated voltage by a factor of 1.3.

Smart Line Modules in chassis format are suitable for connection to grounded (TN, TT) and non-grounded (IT) supply systems. The following voltages and power ratings are available:

Table 8-9 Smart Line Modules

Line supply voltage	Rated power
380 to 480 V 3 phase AC	250 ... 800 kW
500 to 690 V 3-phase AC	450 ... 1400 kW

The following rules must be observed when connecting Smart Line Modules in parallel:

- Up to four identical Smart Line Modules can be connected in parallel.
- A common Control Unit must always be used to implement the parallel connection.
- A 4% reactor is always required upstream of each Smart Line Module for the purpose of current balancing.
- Special Line Connection Modules are available for the parallel connection.
- With multiple infeeds, power must be supplied to the systems from a common infeed point (i.e. the modules cannot be operated on different line supplies).
- A derating factor of 7.5% must be taken into consideration, regardless of the number of modules connected in parallel.

6-pulse parallel connection of Smart Line Modules

With the 6-pulse parallel connection, up to four Smart Line Modules are supplied by a common two-winding transformer on the line side and synchronously controlled by a common Control Unit.

As Smart Line Modules have no current compensation control, the current must be balanced by the following measures:

- Use of suitable line reactors for the Smart Line Modules.
- Use of symmetrical power cabling between the transformer and the parallel-connected Smart Line Modules (cables of identical type with the same cross-section and length).
- The current reduction (derating) from the rated value for individual Smart Line Modules in a parallel connection is 7.5%.

12-pulse parallel connection of Smart Line Modules

For 12-pulse parallel connections, up to four Smart Line Modules are supplied by a three-winding transformer on the line side. In this case, an even number of modules, i.e. two or four, must be divided between the two secondary windings. In contrast to Basic Line Modules, the Smart Line Modules of both subsystems have to be controlled by two Control Units due to the 30° phase displacement in the input voltages.

8.10.1.3 Parallel connection of Active Line Modules

Active Line Modules can supply motoring energy and return regenerative energy to the line supply.

The parallel connection of up to four Active Line Modules is supplied by a shared two-winding transformer and controlled synchronously by a shared Control Unit. The modules must not be connected to the supply via a three-winding transformer with phase-displaced secondary voltages.

Active Line Modules produce a stabilized DC voltage that remains constant regardless of fluctuations in the line voltage (the line voltage must range within the permissible tolerances).

The DC-link voltage is greater than the rms value of the line rated voltage by a factor of 1.5.

Active Line Modules draw a virtually sinusoidal current from the supply system and cause virtually no line harmonic distortions.

Active Line Modules in chassis format are available for the following voltages and power ratings:

Table 8- 10 Active Line Modules

Line supply voltage	Rated power
380 to 480 V 3 phase AC	132 ... 900 kW
500 to 690 V 3-phase AC	560 ... 1400 kW

The following rules must be observed when connecting Active Line Modules in parallel:

- Up to four identical Active Line Modules can be connected in parallel.
- Active Line Modules can only be connected and operated in parallel in the vector control mode.
- A common Control Unit must always be used to implement the parallel connection.
- Special Line Connection Modules are available for connecting the modules in parallel.
- With multiple infeeds, power must be supplied to the systems from a common infeed point (i.e. the modules cannot be operated on different line supplies).
- A derating factor of 5% must be taken into consideration, regardless of the number of modules connected in parallel.

The following measures help to ensure balanced currents in parallel connections of Active Line Modules:

- Reactors in the Clean Power Filters of the Active Interface Modules.
- Use of symmetrical power cabling between the transformer and the parallel-connected Active Interface Modules / Active Line Modules (cables of identical type with the same cross-section and length).
- The current reduction from the rated value for individual Active Interface Modules / Active Line Modules in a parallel connection is 5%.

6-pulse, redundant parallel connection of Active Line Modules with multiple Control Units

For a description of parallel connections of multiple Active Line Modules under the control of separate Control Units, please refer to section "Master/slave function for Active Infeed (Page 516)".

12-pulse parallel connection of Active Line Modules

The 12-pulse parallel connection can operate in master-slave mode (section "Master/slave function for Active Infeed (Page 516)").

Modules with different ratings can be included in the connection (as in the case of 6-pulse master-slave operation).

8.10.1.4 Parallel connection of Motor Modules

Up to four Motor Modules operating in parallel can supply a single motor in vector control. The motor can have electrically isolated winding systems or a common winding system. The type of winding system defines the following requirements:

- The required decoupling measures at the outputs of the Motor Modules connected in parallel
- The possible modulation systems to generate pulse patterns

In conjunction with the type of infeed, the modulation systems define the maximum attainable output voltage or the maximum attainable motor voltage.

Winding systems for motors in SINAMICS parallel connections

The following are admissible:

- Motors with electrically isolated winding systems (multi-winding system) in which the individual systems are not electrically coupled.
- Motors with a common winding system (single winding system) in which all parallel windings in the motor are interconnected in such a way that from the outside they look like a single winding system.

The following are inadmissible:

- Motors with separate winding systems on the line side which have a common, internal neutral.

Below are two examples illustrating the possible configuration of parallel connections of motors with a two-winding system or single winding system.

Parallel connection of two Motor Modules to one motor with double winding system

Motors in the power range from about 1 MW to 4 MW, for which power units connected in parallel are generally used, frequently have several parallel windings. If these parallel windings are separately routed to the terminal box of the motor, a motor is obtained with winding systems that can be separately accessed. In this case, you can dimension a parallel Motor Module connection so that each motor winding system is precisely supplied from one of the Motor Modules connected in parallel. The diagram below shows this type of arrangement.

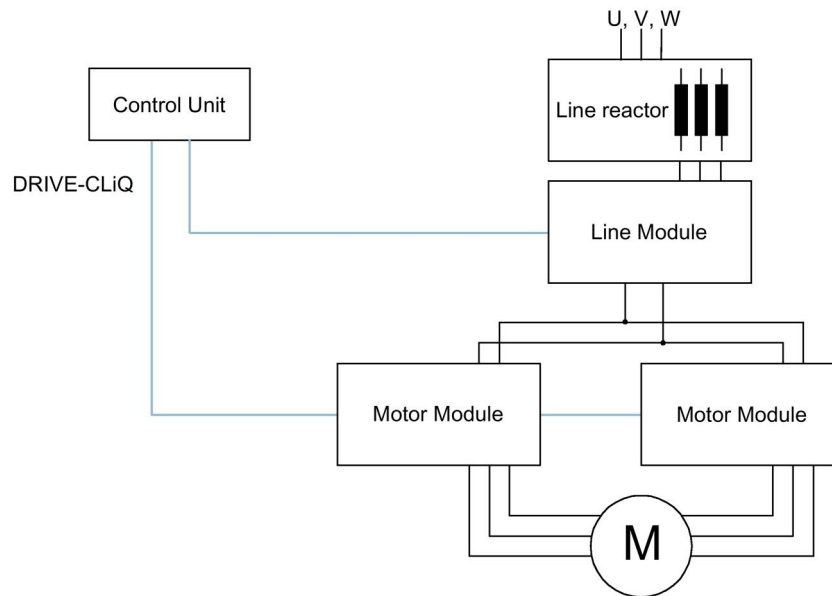

Figure 8-26 Example 1: parallel connection

Owing to the electrical isolation of the winding systems, this arrangement offers the following advantages:

- Decoupling measures are not required at the infeed output in order to limit any potential circulating currents between the parallel-connected Motor Modules (no minimum cable lengths and no motor reactors).
- Both types of modulation system, i.e. space vector modulation and pulse-edge modulation can be used, i.e. when the parallel connection is supplied by Basic Line Modules or Smart Line Modules, the maximum obtainable output voltage is almost equal to the three-phase AC line voltage connected to the infeeds (97%). When the parallel connection is supplied by Active Line Modules, a higher output voltage than the input voltage at the three-phase end can be obtained due to the increased DC-link voltage.

For a parallel connection, the current reduction referred to the rated value for the individual Motor Modules is 5%.

Parallel connection of two Active Line Modules and two Motor Modules on a motor with a single winding system

In many cases, it is not possible to use motors with separate winding systems, for example, in the following cases:

- The required number of separate winding systems cannot be realized due to the pole number
- The motor is a third-party motor
- A motor with a common winding system is already present.

In such cases, the outputs of the Motor Modules connected in parallel are interconnected via the motor cables in the motor terminal box.

Active Interface Modules isolate switching-frequency harmonics from the supply connection and thus effect basic interference suppression of the supply system. These modules are essential to the operation of Active Line Modules. The VSM10 Voltage Sensing Module also helps Active Line Modules to operate properly when mains power conditions are less than ideal (e.g. severe voltage fluctuations, brief interruptions in the line voltage). VSMs are integrated as standard in the Active Interface Modules for Active Line Modules in chassis format.

8.10.2 Commissioning

During commissioning, power units connected in parallel are treated like a power unit on the line or motor side.

Note

Parallel connection of Motor Modules in vector control

You have an offline project in vector control with parallel-connected Motor Modules and then transfer it online to the Control Unit. To save the project in the Control Unit, you must perform a POWER ON. The next time you switch on you receive an error message that the online topology is inconsistent. Load the project now to the programming device. This resolves the inconsistency.

For further detailed information about commissioning, restrictions regarding operation and parameterization options, please refer to the following references

- SINAMICS S120 Commissioning Manual
- SINAMICS S120/S150 List Manual Parameters r7002 ff.

8.10.3 Additional drive in addition to the parallel connection

Frequently, a controlled auxiliary drive is required in addition to the main drives, e.g. as excitation controller for shaft-mounted generators in shipbuilding or as lubricating pump drive, fan drive etc.

For drive units with power units connected in parallel (Line Modules, Motor Modules) an additional drive can be supplied as an auxiliary drive. This drive object is supplied via a separate Motor Module from the common DC link and controlled from the CU320-2 via a dedicated DRIVE-CLiQ socket.

Conditions for switching in an auxiliary drive

The secondary conditions for connecting an additional drive object as auxiliary drive to a parallel connection are:

- Only power units of the same type and the same power rating may be connected together in parallel.
- Up to 4 Line Modules and up to 4 Motor Modules can be connected together in parallel.
- All the Power Modules operate on a common DC link.
- Due to the different cycle times, Line Modules and Motor Modules must be connected to separate DRIVE-CLiQ sockets. Mixed operation at one DRIVE-CLiQ socket results in a malfunction.
- Parameter p9620 (signal source for STO/SBC/SS1) of the DOs of all Motor Modules must be interconnected in the same way.
- Automatic commissioning of the additional drive object is not possible.
- The additional drive object must be created offline and then transferred online to the drive.
- The additional drive object must be connected to a separate DRIVE-CLiQ socket.
- The maximum power of the auxiliary drive must be selected so that the maximum power of all the Motor Modules incl. the additional drive - does not exceed the total power rating of the parallel Line Modules.
- Existing supplementary conditions and the resulting logic operations and monitoring functions must be adapted to the new requirements.

Creating a project with the appropriate topology

The required topology can be created using either the STARTER or SCOUT tool:

- The project is always created offline.
- The Control Unit combines parallel-connected power units to form a large Line Module or Motor Module.
- The auxiliary drive is assigned a separate DRIVE-CLiQ line.
- The DRIVE-CLiQ connections must be implemented corresponding to the topology that has been created

Example of the required topology

You can see an example created with STARTER below. 3 Basic Line Modules, 2 Motor Modules and an auxiliary drive are configured. The parallel connections can be clearly seen in the topology tree as one infeed and one drive. You can also see the additional auxiliary drive. The DRIVE-CLiQ connections are shown as a thin line. The three parallel Line Modules are connected to one DRIVE-CLiQ line, the two Motor Modules to the next DRIVE-CLiQ line, and the auxiliary drive to a third line.

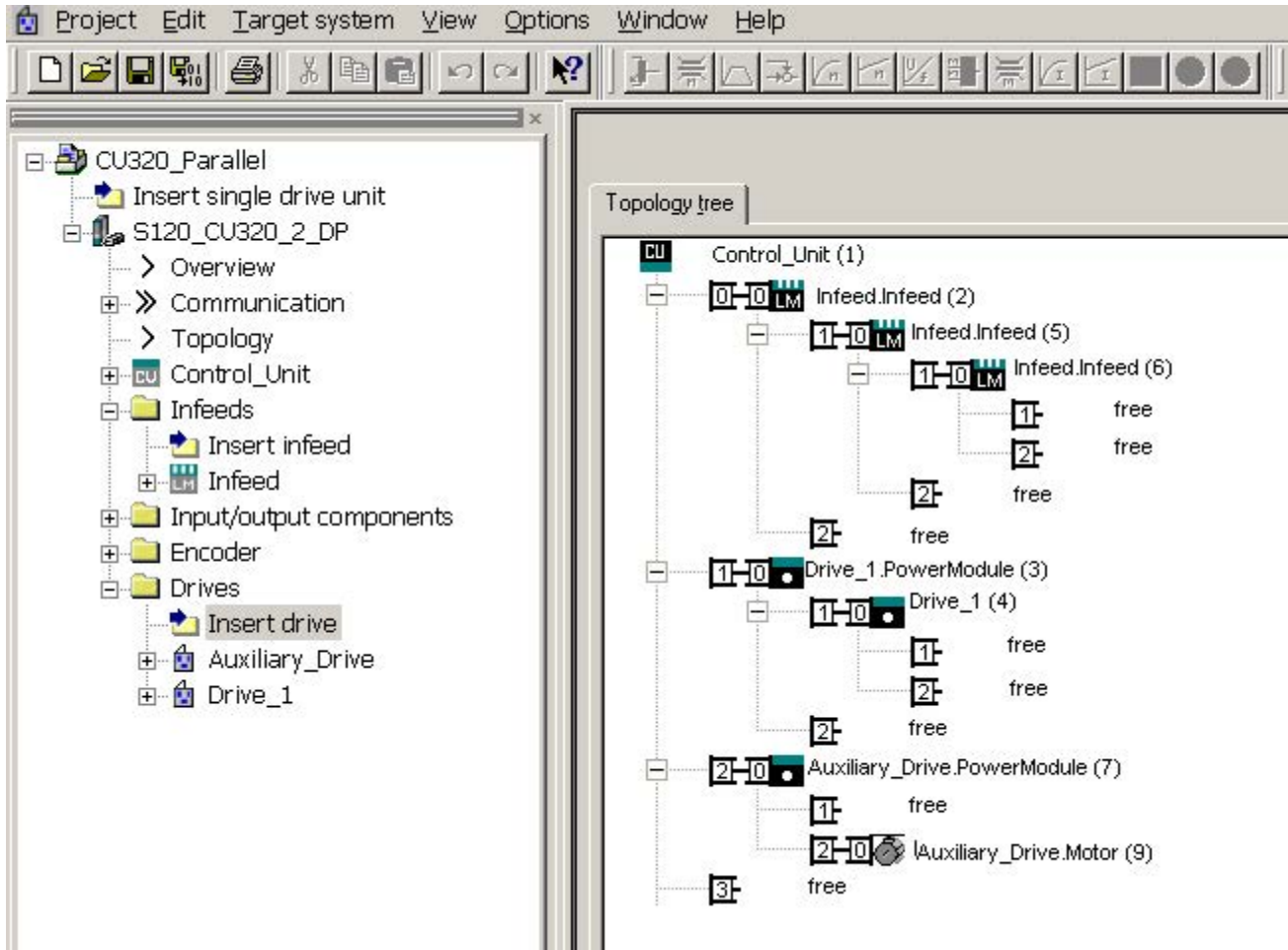

Figure 8-27 Topology with 3 basic Line Modules, 2 Motor Modules and 1 auxiliary drive

Overview of important parameters (see SINAMICS S120/S150 List Manual)

- p0120 Power Module data sets (PDS) number
- p0121[0...n] Power Module component number
- r0289 CO: Power unit output current, maximum
- p0602 Par_circuit power unit number temperature sensor
- p1240[0...n] Vdc controller or Vdc monitoring configuration
- p1280[0...n] Vdc controller or Vdc monitoring configuration (V/f)
- p6397 Motor module phase shift second system
- r7000 Par_circuit number of active power units
- p7001[0...n] Par_circuit enable power units
- r7002[0...n] CO: Par_circuit status power units
- p7003 Par_circuit winding system
- p7010 Par_circuit current unbalance alarm threshold
- p7011 Par_circuit DC link voltage unbalance alarm threshold
- ...
- r7250[0...4] Par_circuit power unit rated power
- r7251[0...4] Par_circuit power unit rated current
- r7252[0...4] Par_circuit power unit maximum current
- ..
- r7320[0...n] Par_circuit VSM line filter capacitance phase U
- r7321[0...n] Par_circuit VSM line filter capacitance phase V
- r7322[0...n] Par_circuit VSM line filter capacitance phase W

8.11 Extended stop and retract

Overview

The "extended stop and retract" function module (ESR) allows a workpiece and tool to be separated without causing any damage when a fault situation occurs. The drive axes involved are defined and are retracted and/or stopped in a controlled fashion. For this function, the drives must be operated with servo control.

The drive-integrated ESR functions are described in this manual:

- Extended stopping of the drive
- Extended retraction of the drive
- Generator operation with monitoring to buffer the DC link voltage

ESR functions can be initiated from the higher-level controller using a trigger signal, or independently in the drives themselves in the event of a fault (the function is integrated in the drive). The ESR functions integrated in the drive act on an axis-for-axis basis.

- Using an axis-specific trigger, ESR functions are directly initiated for an individual axis.
- Using a local trigger on the device itself, the ESR functions are simultaneously initiated for those axes under the drive line that are activated for ESR.

Note

ESR functionality under Safety Integrated Functions

If extended stop and retract are to be activated simultaneously with Safety Integrated Functions, the following conditions must also be satisfied. Further information can be found in the SINAMICS S120 Function Manual Safety Integrated.

Example

For a machine tool, several drives are simultaneously operational, e.g. a workpiece drive and various feed drives for a tool. In the case of a fault, it is not permissible that the tool remains inserted in the workpiece. This could make both unusable. The tool and workpiece must be separated from one another in a controlled fashion before the drives are allowed to come to a standstill.

The "extended stop and retract" function module allows drive-integrated retraction using the feed drives with subsequent stopping. This means, for example when the line supply fails, a drive can be switched into the generator mode. This then supplies energy for the DC link so that the feed drives can retract the tool from the workpiece and then be subsequently stopped.

8.11.1 Activating and enabling the ESR function module

PG/PC and drive are connected with one another via PROFIBUS or PROFINET.

Procedure

1. Select the ESR function with parameter p0888:
 - p0888 = 0: No function
 - p0888 = 1: Extended stopping (function integrated in the drive), N-set
 - p0888 = 2: Extended retraction (function integrated in the drive)
 - p0888 = 3: Generator operation (Vdc controller)
 - p0888 = 4: Extended stopping (function integrated in the drive), N-actual
2. Enable the ESR response with p0889 = 1.
3. Transfer the settings to the Control Unit using the "RAM to ROM" function.

The parameterization of p0888 can be changed from a higher-level control depending on the particular situation - as long as the ESR response is not yet enabled.

You can also activate function modules in STARTER under "Configuration" > "Function modules / technology packages".

You can check the current configuration in parameter r0108.9.

Checking the ESR status

The current ESR status can be checked with the aid of parameter r0887.0...13.

8.11.2 Valid sources for triggering the ESR functions

Axis-related trigger sources

Conditions for triggering the function:

- ESR function has been configured in the drive with p0888, e.g. stopping or retraction.
- ESR function has been enabled in the drive with p0889 = 1.
- The pulse enable has been set.

A distinction is made between the following fault sources:

- Internal drive fault
 - Faults with reactions OFF1 or OFF3
 - p0840 (On/OFF1) and p0849 (OFF3) wired to terminal
- Internal trigger signal
 - The source for the ESR trigger signal is set via BICO using p0890.

Triggering for all drives of a Control Unit

Conditions for triggering the function:

- ESR function has been configured in the drive, e.g. stopping or retraction.
- ESR function has been enabled in the drive.
- The pulse enable has been set.

A distinction is made between the following fault sources:

- Communication failure:
 - The Control Unit detects the communication failure and triggers autonomous reactions in all the enabled drives.
 - A status checkback signal is no longer possible.
 - The higher-level control removes the "Master control by PLC" signal (F07220).
 - Interruption of data transmission via the fieldbus (F01910 or F08501).
- External trigger signal
 - An external trigger signal from the control triggers the ESR function via the telegrams 390, 391 or 392.

8.11.3 Invalid sources

The following DRIVE-CLiQ communication failures do not produce an ESR trigger:

- Pulse suppression of the motor modules is present
The drive switches to OFF2 and coasts to a standstill.
- Failure of encoder modules as motor measuring system
The system is switched to operation without encoder and a parameterized stop response is initiated.
- Failure of encoder modules as a direct application-specific measuring system
The application is shut down and a parameterized stop response is initiated.

8.11.4 ESR responses

8.11.4.1 Extended stopping

In the case of a fault, the objective is to stop the drive in a defined fashion. The stopping method is used as long as the drive is still capable of functioning. The function is parameterized and operates on an axis-specific basis. Axes are not coupled.

Configuring the "Extended stop" response

1. Configure the stopping response with the parameter setting $p0888 = 1$ (N-set) or $p0888 = 4$ (N-actual).
2. Set the time in parameter $p0892$ for which the last setpoint from $r1438$ and the last actual value from $r0063$ are frozen before braking is initiated.
3. Select the OFF ramp with parameter $p0891$.

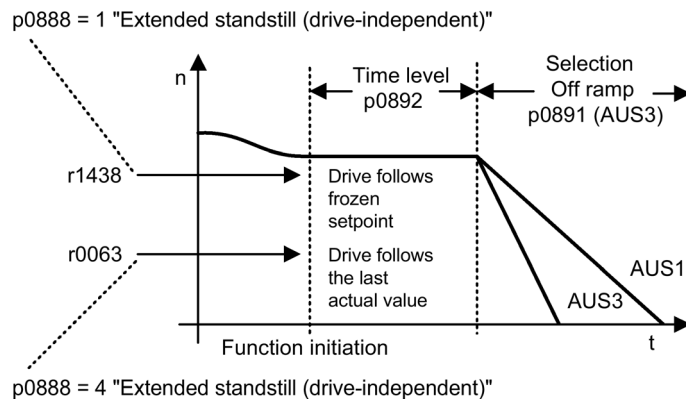

Figure 8-28 OFF ramp with timer

8.11.4.2 Extended retract

In the case of a fault, the objective is to approach a retraction position. The retraction method is used as long as the drive is still capable of functioning. The function is parameterized and operates on an axis-specific basis. Interpolating coupling of the axes is not realized.

Configuring the "Extended retract" response

1. Configure the retract response with p0888 = 2.
2. Define the retraction speed with parameter p0893.
3. Use parameter p0892 to specify how long the retraction speed is to be applied.
4. Select the OFF ramp with parameter p0891.

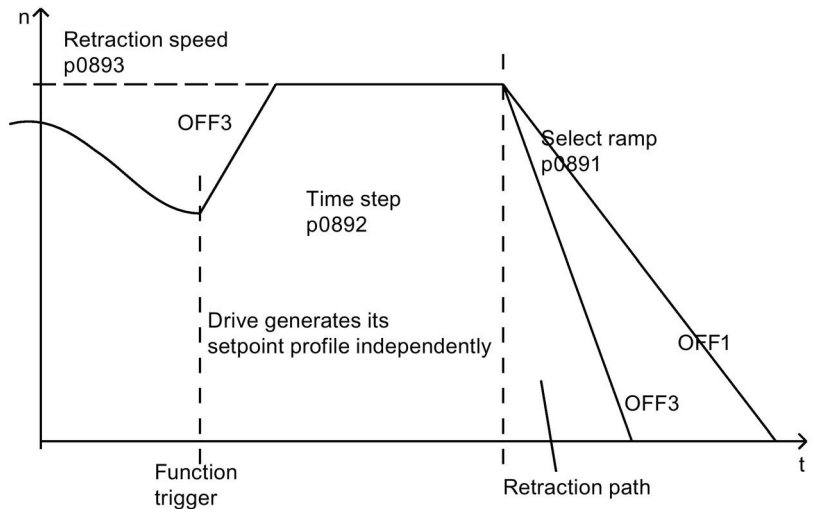

Figure 8-29 OFF ramp with "extended retract"

The retraction speed is not approached suddenly. It is approached via the OFF3 ramp.

Parameter p0893 supplies the ramp-function generator with the setpoint for the ESR retraction speed which is actuated by an OFF3 ramp in the case of drive-autonomous motions. The safety setpoint velocity limiting p1051/p1052 and the normal velocity limits r1084/r1087 are active.

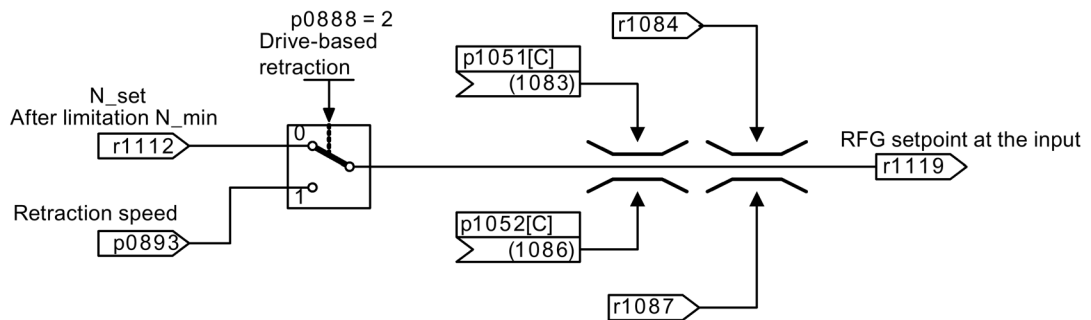

Figure 8-30 Connecting the setpoint channel to the ramp-function generator

8.11.4.3 Regenerative operation

In the case of a fault, the objective is to buffer the DC link until all of the drives connected to the DC link and enabled by ESR have reached their configured final position. To achieve this, a suitable drive in the drive line-up, for example a spindle drive, is braked in generator operation. The DC-link voltage is then monitored by the V_{dc_min} controller.

Configuring the "Generator operation" response

1. Set the generator operation of the drive with the parameter setting $p0888 = 3$.
2. Parameterize the V_{dc} controller.
3. Activate the monitoring of the DC-link voltage for the generator operation with the parameter setting $p1240 = 2$.
4. Set the permissible lower voltage limit V_{dc_min} of the DC link via parameter $p1248$.

The infeed detects when the power fails as the DC-link voltage drops and this is then signaled as an alarm.

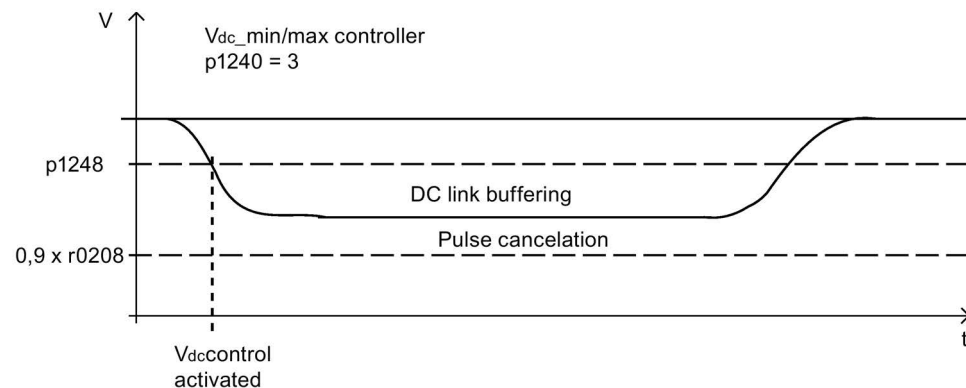

Figure 8-31 DC-link voltage setpoint

8.11.5 Restrictions for ESR

- Operating several axes in the generator mode

Only use one speed-controlled axis to buffer the DC link. If you have parameterized several axes, faults can occur, which undesirably influence one another and therefore the drive line-up as a whole.

- Motors that are not suitable for generator operation

Linear motors (1FN) and torque motors (1FW) require an adequately high DC-link voltage to brake. They are not suitable to buffer the DC link when operating in the generator mode.

- ESR and Safety Integrated

If the Safety Integrated Extended Functions are controlled via PROFIsafe, in the case of a communication failure, Safety Integrated only permits a response time ($p9580/p9380$) of maximum 800 ms. After this time expires, Safety Integrated requests pulse suppression.

8.11.6 PROFIdrive telegram for ESR

A cyclic bit for CU_STW1 is present in PROFIdrive DO telegrams 390, 391, 392, 393, 394, 395 and 396 to monitor the ESR state.

Table 8- 11 CU_STW1

Signal	Meaning	Interconnection parameters
CU_STW1.2	ESR trigger	p0890.9 = r2090.2

Cyclic bits for STW1 and MELDW are present in the telegrams.

Table 8- 12 STW1

Signal	Meaning	Interconnection parameters
STW1.9	1 = Enable ESR response	p0889 = r2090.9

Table 8- 13 MELDW

Signal	Meaning	Interconnection parameters
MELDW.2	1 = $ n_{act} < \text{speed threshold value 3 (p2161)}$	p2082[2] = r2199.0
MELDW.4	1 = Vdc_min controller active ($V_{dc} < p1248$)	p2082[4] = r0056.15
MELDW.9	1 = ESR response initiated / generator operation active	p2082[9] = r0887.12

8.11.7 Function diagrams and parameters

Function diagrams (see SINAMICS S120/S150 List Manual)

- 2443 PROFIdrive - STW1 control word interconnection (p2038 = 1)
- 2456 PROFIdrive - MELDW status word interconnection
- 2495 PROFIdrive - CU_STW1 control word 1, Control Unit interconnection
- 3082 Setpoint channel - extended stop and retract (ESR, r0108.9 = 1)

Overview of important parameters (see SINAMICS S120/S150 List Manual)

- r0063 CO: actual speed value
- p0108[0...n] Drive object function module
- r0108.9 Drive object function module; extended stop and retract / ESR
- r0887 BO: ESR status word
- p0888.0...13 ESR configuration
- p0889 BI: Enable ESR response
- p0890[0...4] BI: ESR trigger
- p0891 ESR OFF ramp
- p0892 ESR timer
- p0893 ESR velocity / ESR speed
- p1051[0...n] CI: Speed limit in RFG, positive direction of rotation
- p1052[0...n] CI: Velocity limit RFG, negative direction
- r1084 CO: Speed limit positive effective
- r1087 CO: Speed limit negative effective
- p1240[0...n] Vdc controller or Vdc monitoring configuration
- p1248[0...n] Lower DC link voltage threshold
- r1438 CO: Speed controller, speed setpoint
- p9380 SI Motion stop response delay bus failure (Motor Module)
- p9580 SI Motion stop response delay bus failure (Control Unit)

8.12 Moment of inertia estimator

8.12.1 Introduction

Features

The "Moment of inertia estimator" function is required when the moments of inertia of the drive change considerably during operation (e.g. when using tools or workpieces with different moments of inertia). For this situation, continuously repeating the rotating motor data identification to determine the moment of inertia would be too complex, or impossible on a machine. For servo control, the "Moment of inertia estimator" is also required for the "Online tuning (Page 113)" function.

Moment of inertia precontrol (Page 553) can be configured for vector control. This is especially advantageous for applications, where the moment of inertia cannot be calculated as a result of a constant motor speed.

Note

The description is also valid for linear motion (torque -> force, moment of inertia -> inertia, speed -> velocity)

You can also activate the moment of inertia estimator during operation with or without an encoder.

Operation without encoder:

- For operation without encoder, the total moment of inertia of the motor and driven machine must be known.
- In controlled operation without encoder (for speeds less than p1755) in the acceleration phase, it is not permissible that the motor stalls because of moment or inertia that has been parameterized too small.
- In controlled operation without encoder (for speeds above p1755), the speed/torque precontrol requires the precise moment of inertia in order to achieve the optimal speed controller dynamic response. An incorrect moment of inertia at the end of the acceleration phase, results in an undesirable overshoot or undershoot.

Operation with encoder

- For operation with encoder (**without** online tuning), the moment of inertia is only included in the motor control when the speed/torque precontrol has been activated (p1402.4 = 1).
- For servo control with encoder (**with** online tuning), the relevant controller parameters for the speed and position controller are set automatically. The automatic calculation of the controller parameters also depends on the estimated moment of inertia.

Determining the load torque

The load torque must first be determined to determine the moment of inertia.

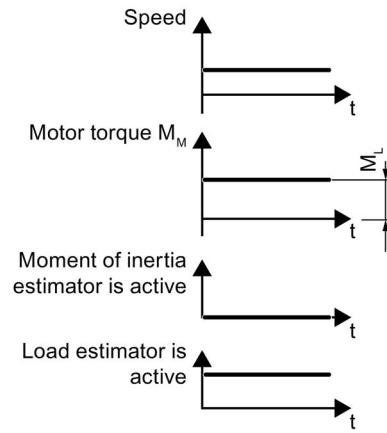

Phases with constant speed not equal to zero are required to determine the load torque (e.g. friction force). For small speed changes, the converter calculates the load torque M_L from the actual motor torque. The following conditions must be satisfied to do this:

- Speed \geq p1226
- Acceleration setpoint $< 8 \text{ 1/s}^2$
- Acceleration \times moment of inertia (r1493) $< 0.9 \times$ p1560

After determining the load torque, the moment of inertia can be determined in the acceleration phases. If the source of p1502 has a 1 signal, the moment of inertia is not estimated.

The accuracy of the moment of inertia estimation increases as the acceleration rate increases. The start value of the moment of inertia estimator is the parameterized moment of inertia (p0341 \times p0342 + p1498).

Determining the moment of inertia

For larger speed changes, the inverter initially calculates the accelerating torque M_B as the difference between the motor torque M_M , load torque M_L and frictional torque M_R :

$$M_B = M_M - M_L - M_R$$

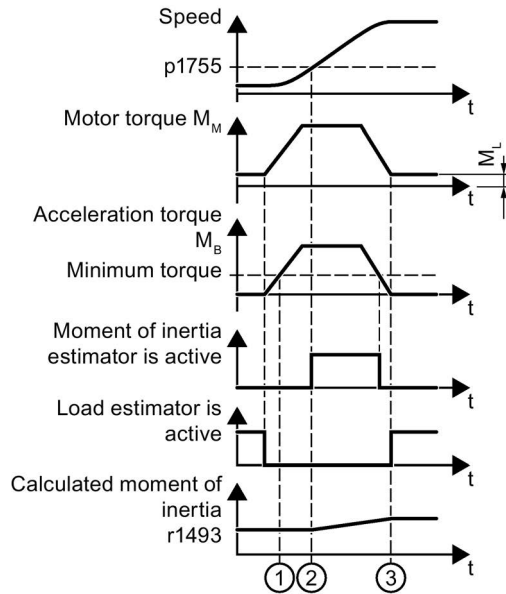

The moment of inertia J of the motor and load is then obtained from the accelerating torque M_B – and the angular acceleration α

$$J = M_B / \alpha.$$

The following conditions must be fulfilled for this calculation:

- ① Acceleration torque M_B must be
> than $p1560 \times r0333$ (rated motor torque) and
> than 80 % of the friction torque ($0.4 \times (p1563 - p1564)$).
- ② For operation without encoder, the speed must be > $p1755$ (in closed-loop controlled operation).
- ③ The converter calculates the load torque again after acceleration.

If the load estimation has taken place and the moment of inertia does not settle (stabilize) ($r1407.24/26 = 0$), then increasing the acceleration ($p2572/p2573$) is recommended.

If the load moment of inertia is significantly greater than the motor moment of inertia, then the transient event can also be improved via parameterization of the load moment of inertia ($p1498$).

The results of the moment of inertia and load estimator can be taken over by permanently saving (RAM to ROM) after the system has settled ($r1407.26 = 1$). If there are no significant changes to the moments of inertia, the inertia estimator can be deactivated after saving. The appropriate signal can be read out of SINUMERIK as soon as the moment of inertia estimator has settled.

Note**Online tuning for servo control**

The values determined by the load and moment of inertia estimator are deleted by deactivating ($p5300 = 0$) and then subsequently reactivating online tuning ($p5300 = 2$).

Restrictions

- The moment of inertia estimator only returns the correct total moment of inertia if the load does not change during the acceleration phases.
- In phases where machining takes place during the speed setpoint change, e.g. thread cutting, the moment inertia estimator can be frozen using a BICO switch (source of $p1502 = 1$). This means that a previous moment of inertia that was correctly determined is not modified as a result of an incorrect estimation. This condition is also violated when, for example, the friction torque changes significantly with the speed. An excessively high backlash (no frictional connection) and fast periodic movements that decouple the masses elastomechanically, can also have a negative effect on the accuracy of the moment of inertia estimation.
- For operation without encoder, the moment of inertia must be parameterized to the highest expected moment of inertia ($p0341 \times p0342 + p1498$), so that the motor does not stall when accelerating for the first time in the controlled range. As long as the pulses are not deleted, the actual estimated value of the moment of inertia is always used in the motor model. This value is stored in $r1493$. The estimated moment of inertia is reset to the parameterized value with each pulse inhibit, if $p1400.22 = 0$ is set. Otherwise, the last determined value is retained at the pulse inhibit.

Note**Online tuning for servo control**

For servo control and active online tuning, the speed controller is automatically adapted with the estimated moment of inertia.

8.12.2 Commissioning

Procedure

To activate the "Moment inertia estimator" function module, proceed as follows:

1. Call the drive configuration offline in STARTER. In the "Configuration" screen form, click the "Function modules / technology packages" button. In the "Object Properties" dialog box, activate the "Moment of inertia estimator" function module.

You can check the current configuration in parameter r0108.10.

2. Make the setting p1400.18 = 1 (moment of inertia estimator active) in the expert list of the drive object:

A data set changeover can be used to activate or deactivate the moment of inertia estimator via p1400.

Note

For servo control, the Online tuning (Page 113) function automatically activates the "Moment of inertia estimator".

Additional settings and special issues

- Using parameters p1561 and p1562, you define how quickly and/or how precisely the moment of inertia should be estimated.
 - The lower the values in both parameters, the shorter the moment of inertia estimator measurements. As a consequence, a quickly changing torque can be better estimated.
 - The higher the values in both parameters, the more precise the values supplied by the moment of inertia estimator.
- If the speed setpoint changes must be performed under load, then you can freeze the currently estimated moment of inertia during this time. To do this, in parameter p1502 set a 1 signal using a BICO switch. For operation with encoder, p1402.4 must also be set = 1.
- The estimated moment of inertia can be monitored in parameter r1493.

Note

If the function for adapting the moment of inertia via BICO technology (p1497 connected) is activated, the moment of inertia estimator is not active.

8.12.3 Supplementary functions of the moment of inertia estimator for vector control

Moment of inertia precontrol

In applications where the motor predominantly operates with a constant speed, the converter can only infrequently calculate the moment of inertia using the function described above. Moment of inertia precontrol is available for situations such as these. The moment of inertia precontrol assumes that there is an approximately linear relationship between the moment of inertia and the load torque.

Note

Moment of inertia precontrol is only possible for vector control. The "Moment of inertia estimator" function module must be activated.

Configuring moment of inertia precontrol

1. Ensure that the acceleration precontrol scaling is not equal to zero: $p1496 \neq 0$.
2. Activate the acceleration model of the speed controller precontrol: $p1400.20 = 1$.
3. Configure the moment of inertia precontrol using $p5310$.

Using bit 0, you can activate the calculation of the characteristic ($p5312 \dots p5315$)

Using bit 1, you can activate the moment of inertia precontrol. The following bit combinations are possible:

$p5310.0 = 0$, $p5310.1 = 0$	Moment of inertia precontrol not active
$p5310.0 = 0$, $p5310.1 = 1$	Cyclic calculation of the coefficients without moment of inertia precontrol (commissioning)
$p5310.0 = 1$, $p5310.1 = 0$	Moment of inertia precontrol activated (without cyclic calculation of the coefficients)
$p5310.0 = 1$, $p5310.1 = 1$	Moment of inertia precontrol activated (with cyclic calculation of the coefficients)

The status word of the moment of inertia precontrol is indicated in $r5311$.

Example

For a horizontal conveyor, in a first approximation, the moment of inertia depends on the load.

The relationship between load torque and torque is saved in the converter as linear characteristic.

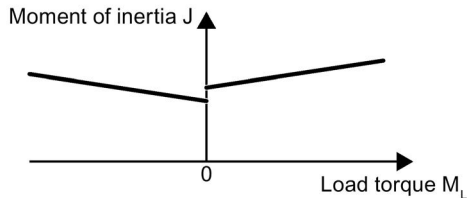

Figure 8-32 Moment of inertia precontrol

- In the positive direction of rotation:
Moment of inertia $J = p5312 \times \text{load torque } M_L + p5313$
- In the negative direction of rotation:
Moment of inertia $J = p5314 \times \text{load torque } M_L + p5315$

You have the following options to determine the characteristic:

- You already know the characteristic from other measurements. In this case, you must set the parameters to known values when commissioning the system.
- The converter iteratively determines the characteristic by performing measurements while the motor is operational.

Additional supplementary functions for vector control

- Accelerated moment of inertia estimation (p1400.24 = 1)
Using this setting, when the drive accelerates steadily, the moment of inertia can be more quickly estimated.
- Speed controller adaptation (p5271.2 = 1)
The estimated load moment of inertia is taken into account for the speed controller gain.

8.12.4 Function diagrams and parameters**Function diagrams (see SINAMICS S120/S150 List Manual)**

- 5035 Servo control - moment of inertia estimator (r0108.10 = 1)
- 6035 Servo control - moment of inertia estimator (r0108.10 = 1)

Overview of important parameters (see SINAMICS S120/S150 List Manual)

- r0108 Drive object function module
- r0333[0...n] Rated motor torque
- p0341[0...n] Motor moment of inertia
- p0342[0...n] Ratio between the total and motor moment of inertia
- p1226[0...n] Speed threshold for standstill detection
- p1400[0...n] Speed control configuration
- p1402[0...n] Current control and motor model configuration
- r1407.0...26/27 CO/BO: Status word, speed controller
- r1493 CO: Moment of inertia, total
- p1496[0...n] Acceleration precontrol scaling
- p1497[0...n] CI: Moment of inertia scaling signal source
- p1498[0...n] Load moment of inertia
- p1502[0...n] BI: Freezing the moment of inertia estimator
- r1518[0...1] CO: Acceleration torque
- r1538 CO: Upper effective torque limit
- r1539 CO: Lower effective torque limit
- p1560[0...n] Moment of inertia estimator acceleration threshold value
- p1561[0...n] Moment of inertia estimator change time moment of inertia
- p1562[0...n] Moment of inertia estimator change time load
- p1563[0...n] CO: Moment of inertia estimator load torque positive direction of rotation
- p1564[0...n] CO: Moment of inertia estimator load torque negative direction of rotation
- p1226[0...n] Speed threshold for standstill detection
- p1755[0...n] Motor model changeover speed encoderless operation
- p5310[0...n] Moment of inertia precontrol configuration
- r5311[0...n] Moment of inertia precontrol status word
- p5312[0...n] Moment of inertia precontrol linear positive
- p5313[0...n] Moment of inertia precontrol constant positive
- p5314[0...n] Moment of inertia precontrol linear negative
- p5315[0...n] Moment of inertia precontrol constant negative
- p5316[0...n] Moment of inertia precontrol change time moment of inertia

8.13 Additional controls for Active Infeed

With the "Additional controls" function module, parameterizable bandstop filters (Page 36) can be used with whose help path resonances can be attenuated.

The main application for these bandstop filters is in weak line supplies in which the resonance point of the line filter can drop to one quarter of the controller frequency.

Activating the function module

1. Select the infeed in the project navigator and open the "Properties" shortcut menu.
The "Object properties" dialog then opens.
2. Click the "Function modules" tab.
3. Activate the "Additional closed-loop controls" function module in the function modules selection with a mouse click.

Parameter r0108.03 indicates whether the function module has been activated.

Function diagrams (see SINAMICS S120/S150 List Manual)

- 8940 Active Infeed - controller modulation depth reserve / controller DC link voltage (p3400.0 = 0)
- 8946 Active Infeed - current precontrol / current controller / gating unit (p3400.0 = 0)

8.14 Advanced Position Control

8.14.1 Introduction

The Advanced Position Control (APC) function module provides closed-loop control related functions to actively dampen/influence mechanical oscillations. APC is not a filter. The function actively responds to measured oscillations using an appropriate manipulated variable. The motor moves to compensate for the oscillation. If the oscillation frequency changes as a result of axis load or mechanical changes, then APC also responds to the modified frequency. The APC function module is calculated in the speed control loop.

Oscillations can be influenced using the motor speed controller (P gain, integrator). There are 2 strategies: With a high gain, the controller is set to optimally respond to disturbances. Frequently, load side oscillations are increased as a result. For a setting that is optimized for damping, although the oscillation is reduced, the control gain must be reduced. This means that the ability to suppress disturbances is reduced. The APC function module provides additional functions, which resolve this conflict. Using APC, it is possible to dampen/attenuate oscillation, and at the same suppress disturbances with a high speed control gain.

Mechanical oscillations can be excited in 2 ways:

- **Excitation by the command variable** (setpoint motion of the axis)

In this case, oscillation can be reduced by influencing the command variable (setpoint), e.g. by changing the acceleration, limiting jerk or by using a setpoint filter. This function has the disadvantage that generally machining or cycle times are increased. Further, using a setpoint filter frequently results in a higher degree of inaccuracy when emulating contours.

APC can reduce oscillation without having this disadvantage.

- **Excitation by disturbing variables** (e.g. as a result of periodic process forces)

In this particular case, oscillation can only be influenced using active closed-loop control.

In both cases, in order to successfully and effectively use APC, the oscillation must be able to be measured using a measuring system/sensor assigned to the axis. The function module offers different versions to achieve this. APC can only be adjusted using motor variables (motor encoder, current). A direct measuring system if available can be used for the APC. Further, it is possible to integrate an external acceleration sensor into the system and use this for the APC.

APC application examples

- Using APC, it is possible to improve the response of a position control superimposed on a speed control. Frequently, a higher position control gain can be set by dampening the critical oscillation in the speed control loop. This especially applies, if the position control uses a direct measuring system for control.
- If, as a result of periodic process forces (e.g. heavy roughing of steel), the process is excited or instability occurs (regenerative chatter), then APC can dampen this natural oscillation. The process is no longer unstable as a result of this damping. Higher machine feedrates are possible - or thicker workpieces can be machined.
- Oscillations of the mechanical structure are excited in the process by the setpoint motion of the axes. These oscillations negatively impact the process (e.g. when finishing surfaces in mold making). The process must be made slower to avoid these oscillations occurring. APC dampens the oscillation and avoids these disadvantages. The process can be accelerated (higher yield rates).

Note

The functions integrated in APC represent their own control loop - or provide the possibility of intervening in the speed control loop. As a consequence, parameterizing the APC is critical from a stability standpoint.

To optimize APC in conjunction with a direct measuring system requires a deep understanding of control technology (e.g. interpretation of frequency responses).

Examples are shown in the following descriptions of the various functions, which influence the closed-loop control function. A description is given as to which measuring functions are available for measuring the control loops (also see Chapter "Measuring frequency responses (Page 585)").

The APC function should be set before optimizing the speed control.

Note

Dampening the oscillation is achieved by moving the motor to oppose the oscillation. When correctly parameterized, oscillation is dampened and the amplitude on the load side of the mechanical system reduced. However, the motor itself moves more. This means that the mechanical transmission elements between the motor and load (e.g. gearboxes) are subject to an alternating variable and a high initial amplitude.

Overview of the functions integrated in APC

The APC function module can be subdivided into 4 main subfunctions:

- APC without sensor on the load side (Page 562):
 - Rugged function to dampen oscillation.
 - Does not require a direct measuring system
- APC with encoder combination and differential position feedback (Page 568):
 - Influencing the speed controller loop. The speed control response can be improved (e.g. by increasing the speed controller gain).
 - Requires a direct measuring system.
 - 2 functions are involved, which can be advantageously used together.
- APC with acceleration feedback (Page 573):
 - Requires a direct measuring system.
 - Uses the acceleration - measured using the direct measuring system - to dampen oscillation.
 - An external acceleration sensor can be used instead of measuring the acceleration using a direct measuring system.
- APC with load velocity control (Page 580):
 - Requires a direct measuring system.
 - P control of the velocity at the direct measuring system.

Preconditions

- The "Advanced Position Control" (APC, r0108.7) function module for SINAMICS S120 is only available for servo control.
- For some functions integrated in the APC, a 2nd measuring system is required. A more detailed description of the associated preconditions is documented in the description of the various subfunctions.
- Based on experience, frequencies of up to 100 Hz can be influenced by APC. Whether an oscillation can be influenced depends on how the mechanical system affects the closed-control - or how the speed controller loop was set.

8.14.2 Commissioning the function module

Activating the function module in Sinumerik

For Sinumerik, the function module cannot be activated from STARTER. However, the drive commission functionality of Sinumerik Operate provides support. The APC function module can be selected for activation in the menu "Commissioning > Drive system > Drives > Change".

Setting the transmission ratio

It is not sufficient to just activate the function module if APC is being used in conjunction with a direct measuring system. Further, a mechanical transmission ratio must be set between the direct measuring system and the motor measuring system.

If the position controller function module is activated (not for Sinumerik!), then this setting can be made in STARTER from the screen form "Technology > Position control > Mechanics"

If this is not the case, then the setting must be made using the Expert list. This is only possible if the drive has not been enabled ($r0002 > 0$). The following steps are required:

1. $p0010 = 25$: position control commissioning
2. For all drives: Setting the gear ratio
 - $p2504 =$ gearbox motor revolutions (Sinumerik: Axis MD 31060)
 - $p2505 =$ gearbox load revolutions (Sinumerik: Axis MD 31050)
3. Only for linear axes:
 - $p2503 = 1.000.000$ (indicates that the internal resolution $1 \text{ LU} = 1 \mu\text{m}$)
 - $p2506 =$ leadscrew pitch in μm (Sinumerik: Axis MD 31030 * 1000)
4. $p0010 = 0$
5. Backup drive

Note

If, for the direct measuring system, the measuring direction must be inverted, then the speed and the position inversion must be activated together ($p410[1].1 = p410[1].0 = 1$), so that $p410[1] = 3H$.

If the measuring direction for the direct measuring system matches the measuring direction of the motor measuring system, then $p410[1]$ must be parameterized = $0H$.

Licensing

For SINAMICS standalone, this involves an axis license (see Chapter "Licensing (Page 1002)").

For Sinamics with Sinumerik, this involves a machine license within Sinumerik. The license can be activated in Sinumerik Operate in the menu "Commissioning > Licenses". (The general machine data 19308.1 is set = 1). Activation means that the NC must be switched on (power on).

Preassigning parameters

It makes sense to assign some APC parameters in advance.

Default value	Explanation
p3702: APC load speed/motor speed weighting	For reasons relating to the compatibility to older software releases, the value is pre-assigned 1 To optimize the encoder combination, a starting value of 0 is set.
p3778: APC speed limit	Setting the limit for the APC output value. For Siemens standard motors (1FT, 1FK) with rated speeds in the range 2000 ... 6000 rpm, then it makes sense to have a speed limit of about 500 rpm. The limit can be set, so that the required manipulated variable of the APC controller is reached.
p3779: APC speed limit monitoring time	Monitoring time for speed limiting. A suitable value is 50 ms.
Selecting the direct measuring system	If a direct measuring system is used, then this must be selected for the APC. As standard, the second drive measuring system (p3701 = [2] encoder 2) is used. A possibly existing third measuring system (p3701 = [3] encoder 3) can be used. Further, a measuring system from another signal source can be used. To do this, BICO sink p3749 provided for the purpose is wired (set the signal scaling using p3748). This is activated using p3700.9 = 1 (p3701 is then ignored). This case is especially interesting for master-slave axes (see also the example provided in Chapter "APC with load velocity control (Page 580)").
Using an external acceleration sensor	The acceleration sensor must be integrated into the system (e.g. using a TM31 module). The function is activated in the APC using p3700.1 = 1. The acceleration sensor signal must be wired to BICO sink p3750. For this purpose, a highpass filter to filter low frequencies can be set in p3751.
Optional: Taking into account the setpoint acceleration of the axis	For applications where a high contour precision is required (in the mold making area) we recommend that p3700.3 is set = 1. This means that the actual setpoint acceleration of the axis is taken into account in the APC calculation.

After preassigning the parameters, carry out a RAM to ROM data backup.

Note

Using p3749

- When interconnecting a speed actual value from another axis, we recommend that the "Speed information available" bit (r1992.11) is evaluated (e.g. interconnect to an external fault p2106 ... p2108).
- To avoid an additional dead time as a result of the calculation sequence, we recommend that the drive object of signal source of p3749 is set with a higher priority (p7900).

8.14.3 APC without sensor on the load side

Description

This function involves a rugged technique to dampen oscillation without having to use a direct measuring system. Only the current and speed actual values signals measured at the motor are used. The function can be especially used for drives with linear or torque motors, which frequently do not use a direct measuring system.

In order that the function can be successfully used, the oscillation to be dampened must have a sufficient effect on the axis motor. This means that the oscillation must be able to be measured in the motor current.

Before the function can be optimized, the speed controller loop must first be optimized as this forms the subordinate control loop.

Note

The function can also be used if a direct measuring system exists. It is possible that this function offers advantages over using a direct measuring system. Generally, the ruggedness of this function is better, e.g. when the mechanical system changes.

The control without a sensor can also be combined with the P component (p3760/p3765) of the direct measuring system if a direct measuring system exists. This increases the suppression of disturbances and also increases the accuracy.

Function diagram (excerpt from function diagram 7012)

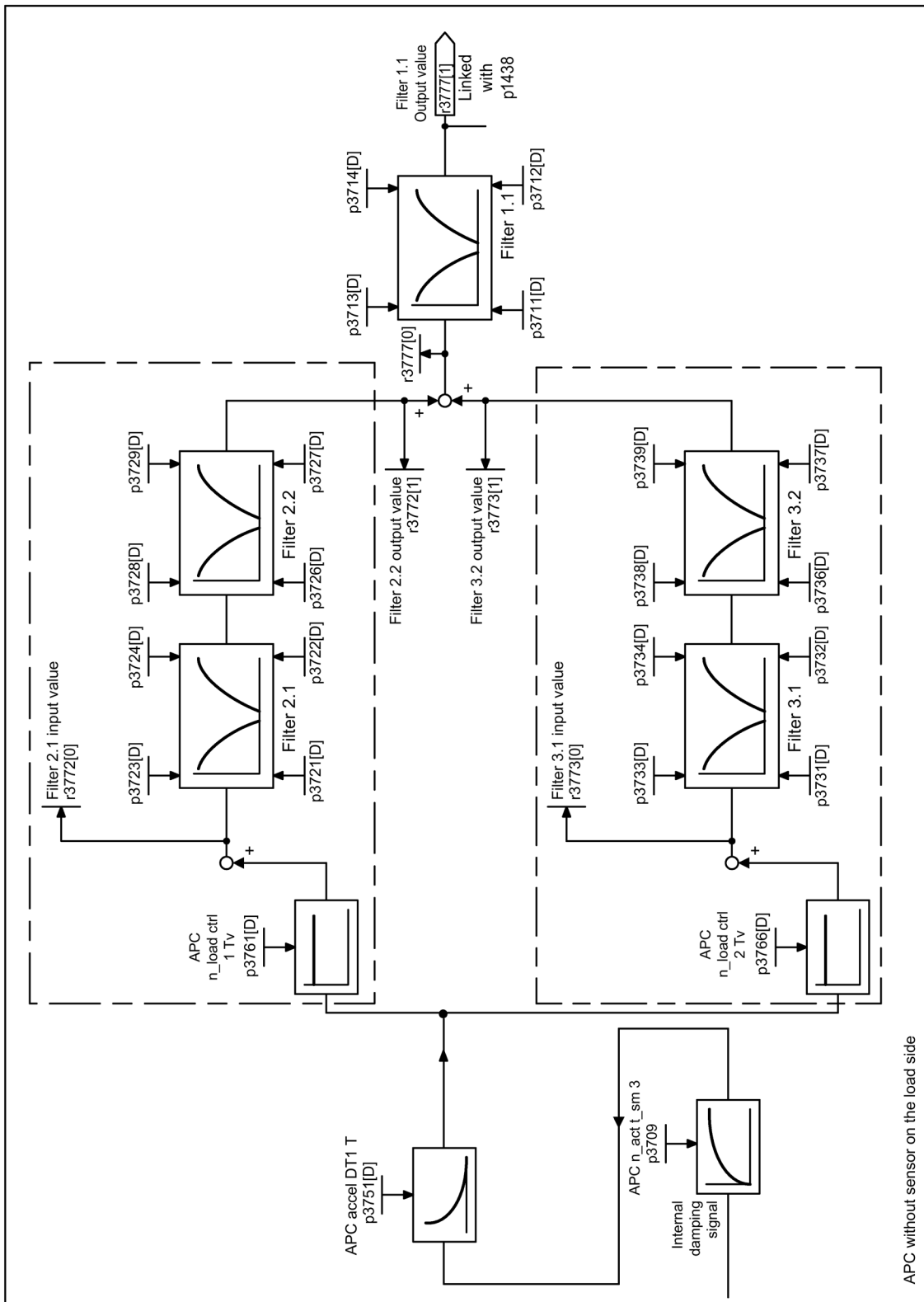

Important notes for parameterization

The function is activated using $p3700.2 = 1$.

The function uses information about the moment of inertia of the motor and axis, which is parameterized outside the APC function module. Parameter $p0341$ (motor moment of inertia), $p0342$ (scaling, motor moment of inertia) and $p1498$ (load moment of inertia) are used. The formula for the overall moment of inertia is $(p0341 \times p0342 + p1498)$. These parameters should be correctly parameterized before optimizing the function. The values are incorporated in the control loop gain! This means that if the value is subsequently changed, this can impact the control - and in the worst-case scenario, can even result in control instability.

The first optimization of the function can be very quickly and simply performed using parameter $p3752$. The axis oscillation frequency is parameterized. If this value is changed, then automatically parameters $p3709$ (PT1 lowpass), $p3751$ (highpass) and $p3761$ (controller gain) are overwritten with a preassignment, depending on this frequency. The moments of inertia are incorporated in the calculation (see the section above). It is important that these values are correctly preassigned for the calculation.

It makes sense to use a PT1 lowpass filter ($p3709$). We recommend a time constant that is approximately 1/10 of the oscillation frequency in Hz.

The highpass filter is active ($p3751$). It can make sense to use this, especially if in the process, the axis is subject to static or low-frequency forces.

Two feedback branches via $p3761$ and via $p3766$ are active. However, generally it is sufficient to just use the first branch ($p3761$). Frequently, practical values for the gain lie in a range between 1 ms and 10 ms; however, this depends on the mechanical system of the axis.

The APC filters are also effective, and when required can be used (see Chapter "Additional Information (Page 583)").

For applications where a high contour precision is required (in the mold making area) we recommend that $p3700.3$ is set = 1. As a consequence, the setpoint motion of the axis within APC is better taken into account.

Measuring the function

The following measuring functions can be used to measure the "APC without sensor on the load side" function:

- APC open circuit
- APC closed circuit (if a direct measuring system is being used)
- Speed controller reference frequency response
- Position controller reference frequency response

You can find detailed information on how to perform these measurements in Chapter "Measuring frequency responses (Page 585)".

Examples:

The diagram shows, as example, how an open APC circuit can be measured. The stability of the control loop can be identified based on the amplitude reserve at the frequency where the phase goes through -180° (in the example, at 200 Hz).

A damping effect is achieved, if, at the oscillation frequency (in the example, 18 Hz) the phase is approximately at 0° - and at the same time the amplitude is in the vicinity of 0 dB.

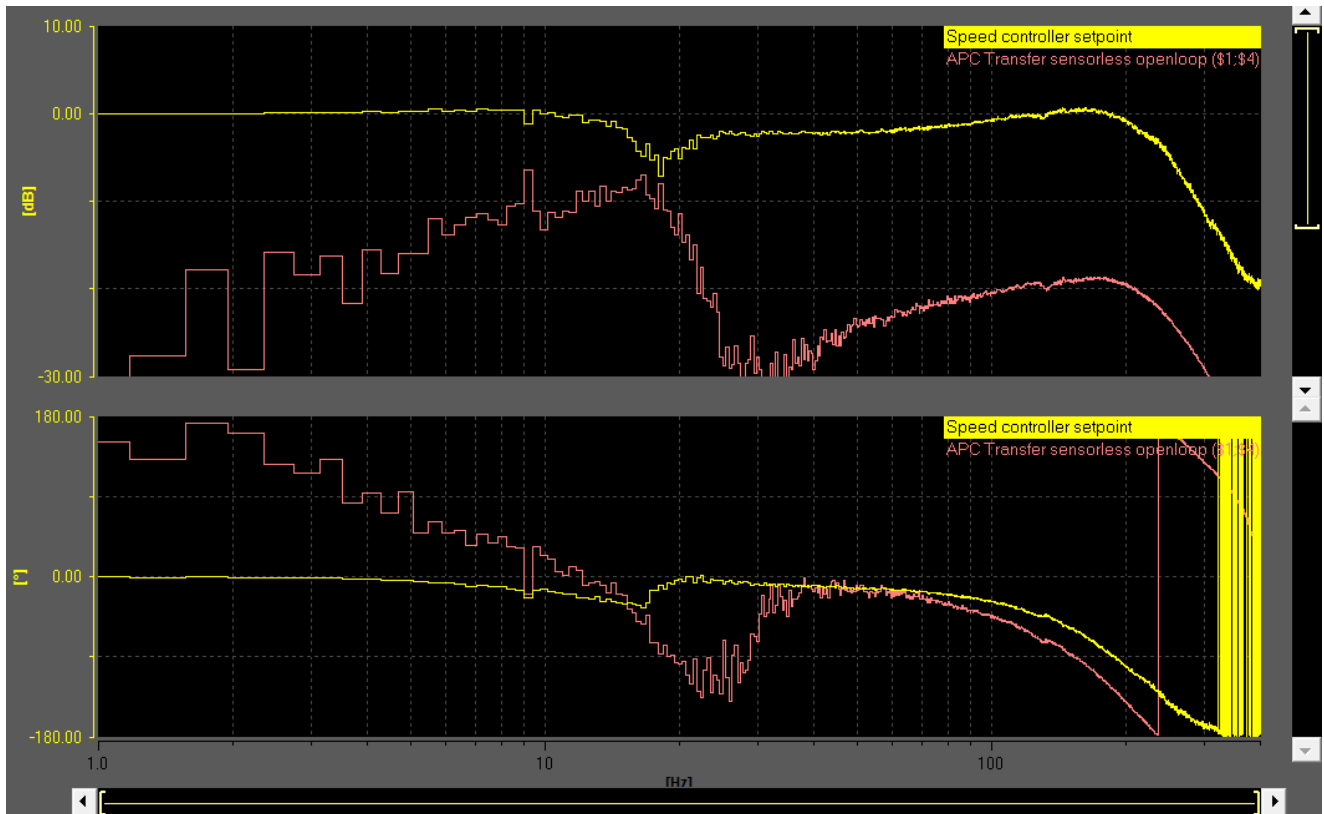
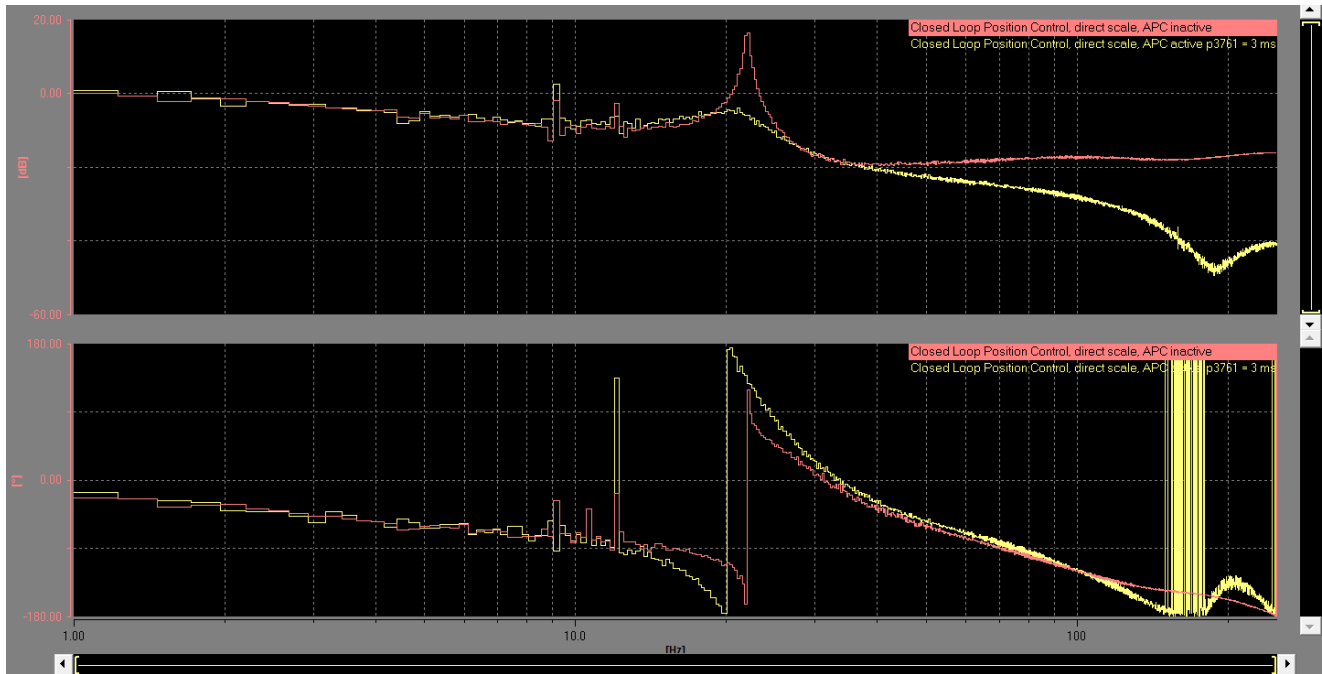

Figure 8-33 APC without sensor on the load side (p3700 = 4) – open circuit

It only makes sense to measure the closed APC circuit if a direct measuring system is being used. See also the examples in Chapter "APC with acceleration feedback (Page 573)". The effect of the functions on the frequency response is very similar in both cases.



- Red: APC inactive: The closed-loop control is at the limit of its stability. The position control gain is too high.
- Yellow: APC active, p3761 = 3 ms: The oscillation is damped. The position control gain can be kept - or even increased slightly.

Figure 8-34 Reference frequency response, position controller, control on a direct measuring system

If a direct measuring system exists, then the APC can be set well by measuring the reference frequency response of the position controller. In the example the damping effect as a result of APC can be seen for an oscillation frequency of 22 Hz.

Examples: Positioning response with and without APC

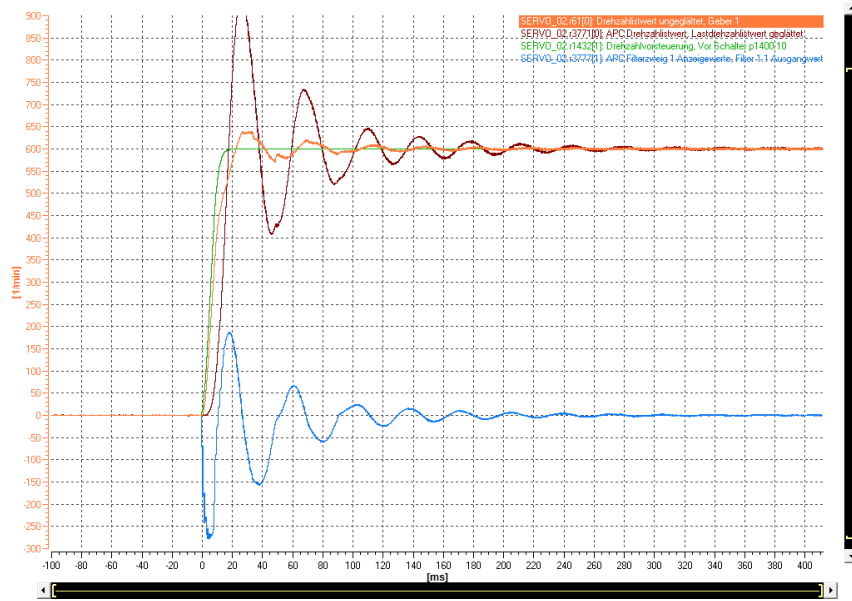

Figure 8-35 Positioning response: without APC

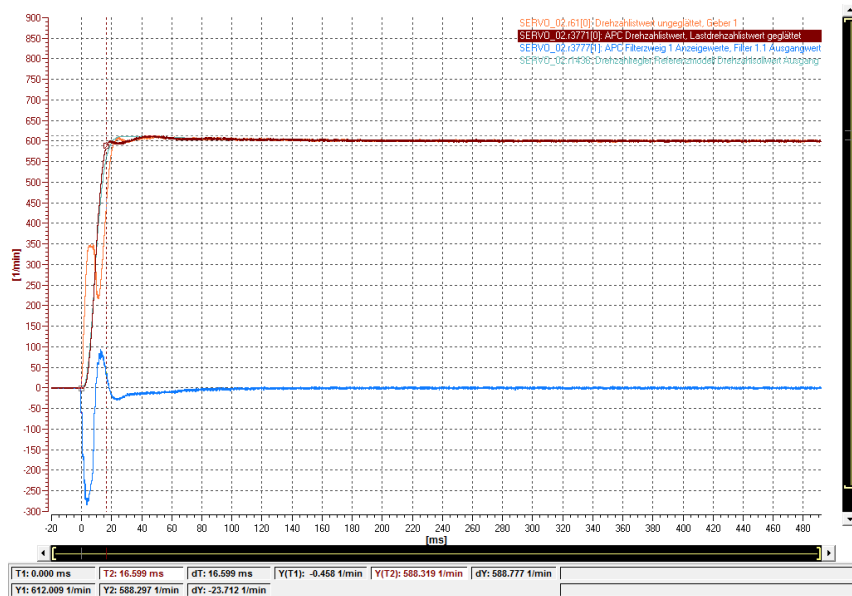

Figure 8-36 Positioning response: APC ideally set

Measured signals:

Orange: r0061[0] motor speed/velocity

Brown: r3771[0] load speed/velocity

Light blue: r3777[1] APC output

8.14.4 APC with encoder combination and differential position feedback:

Description

The control loop for the speed control can be influenced using these two functions. The encoder combination acts on the zero positions (quenching frequencies) of the system - and the differential position feedback on the pole (resonant frequencies). Frequently, it makes sense to use both functions together.

The encoder combination and the differential position feedback are always optimized together with the speed control optimization. Generally, it makes sense to first parameterize the differential position feedback and then the encoder combination.

Application examples:

- The ratio between the load moment of inertia and the motor moment of inertia is very high. The oscillation frequency is relatively low. In this case, frequently only a very low speed controller gain can be set.
Using the encoder combination, the zero position can be shifted towards higher frequencies. The effective moment of inertia on the motor side is increased, and as a consequence, a higher speed controller gain can be set. This effect can be reinforced by combining with the differential position feedback.
- The effect of a natural oscillation at the motor is only very low (e.g. as a result of a high gearbox ratio). This means that the speed controller has no influence on the oscillation. The effects of the oscillation at the motor can be made more obvious by using a combination of encoders and differential position feedback. The speed controller can be set so that optimum damping is achieved. This especially makes sense if no additional APC functions are being used.

The oscillation can be shifted to higher frequencies by combining encoders and differential position feedback. The speed controller can then be set with a high gain to optimally respond to disturbances. An additional APC function is used to dampen oscillations, e.g. acceleration feedback (see Chapter "APC with acceleration feedback (Page 573)").

Note

By using an encoder combination and the differential position feedback, not only are the dominant natural oscillations shifted in the control loop, but all natural oscillations originating from the mechanical system between the two measuring systems. It is possible that a natural oscillation, which actually should not be influenced, negatively influences the speed control. This must be carefully observed when optimizing.

Function diagrams

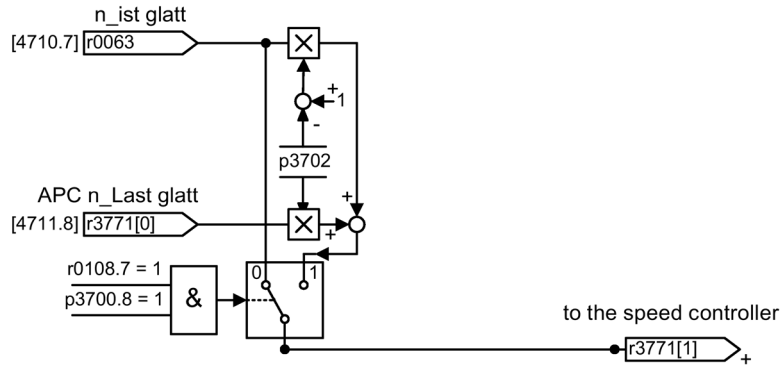

Figure 8-37 APC encoder combination

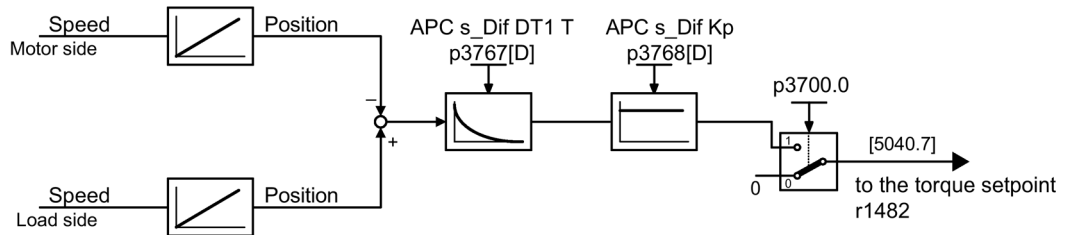

Figure 8-38 APC differential position feedback

Important notes for parameterization

The functions always require a direct measuring system. If an axis is equipped with a measuring system (encoder 2 or encoder 3), then this can be selected using p3701. BICO sink p3749 can be activated by setting p3700.9 = 1. The load speed actual value can now be freely interconnected, e.g. from a master axis. Scaling can be set using p3748.

The encoder combination is activated using p3700.8 = 1. However, differential position feedback is activated using p3700.0 = 1.

Note

If APC was parameterized (p3760, p3761, p3765, p3766 > 0), then this is also activated. Otherwise, this parameter may have to be set to 0.

The weighting factor for encoder combination p3702 has, for compatibility reasons to previous software releases, a default value of 1. For most applications, this value cannot be activated. This value should be set to 0 before activating the encoder combination. Negative values for p3702 are permissible. The oscillation is then shifted to lower frequencies.

The gain of the differential pressure feedback is set in p3768. This parameter has stiffness units (Nm/rad). Practical values for this parameter are approximately the stiffness of the axis itself. This value can differ at a different axes.

Example: The mechanics forms a two-mass oscillating system with a quenching frequency of 20 Hz. The load moment of inertia is 0.01 kgm². The stiffness is then given by:

$$4\pi^2 f^2 j_{last} = 160 \text{ Nm/rad}$$

A highpass filter for the differential position feedback can be parameterized in parameter p3767. The default value is generally sufficient.

Measuring the function

The following measuring functions can be used to measure the "Encoder combination" and "Differential position feedback" functions:

- Speed controlled system (only encoder combination visible)
- Speed controller reference frequency response
- Position controller reference frequency response

You can find detailed information on how to perform these measurements in Chapter "Measuring frequency responses (Page 585)".

Examples

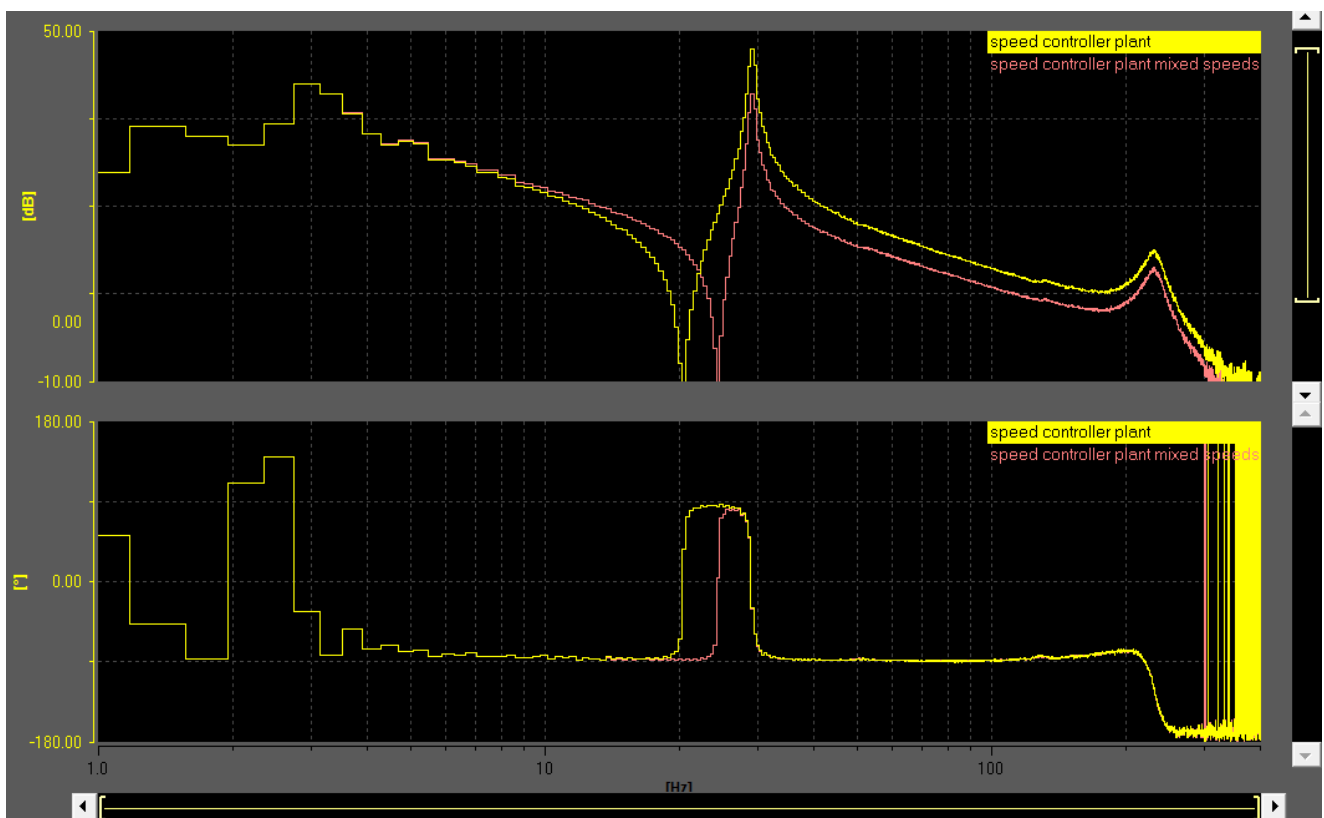

Yellow: Speed controlled system without encoder combination
Red: Speed controlled system with encoder combination (p3702 = 0.3)

Figure 8-39 Encoder combination, effect on the speed control system

As a result of the encoder combination, the quenching frequency is increased from 20 Hz to 24 Hz.

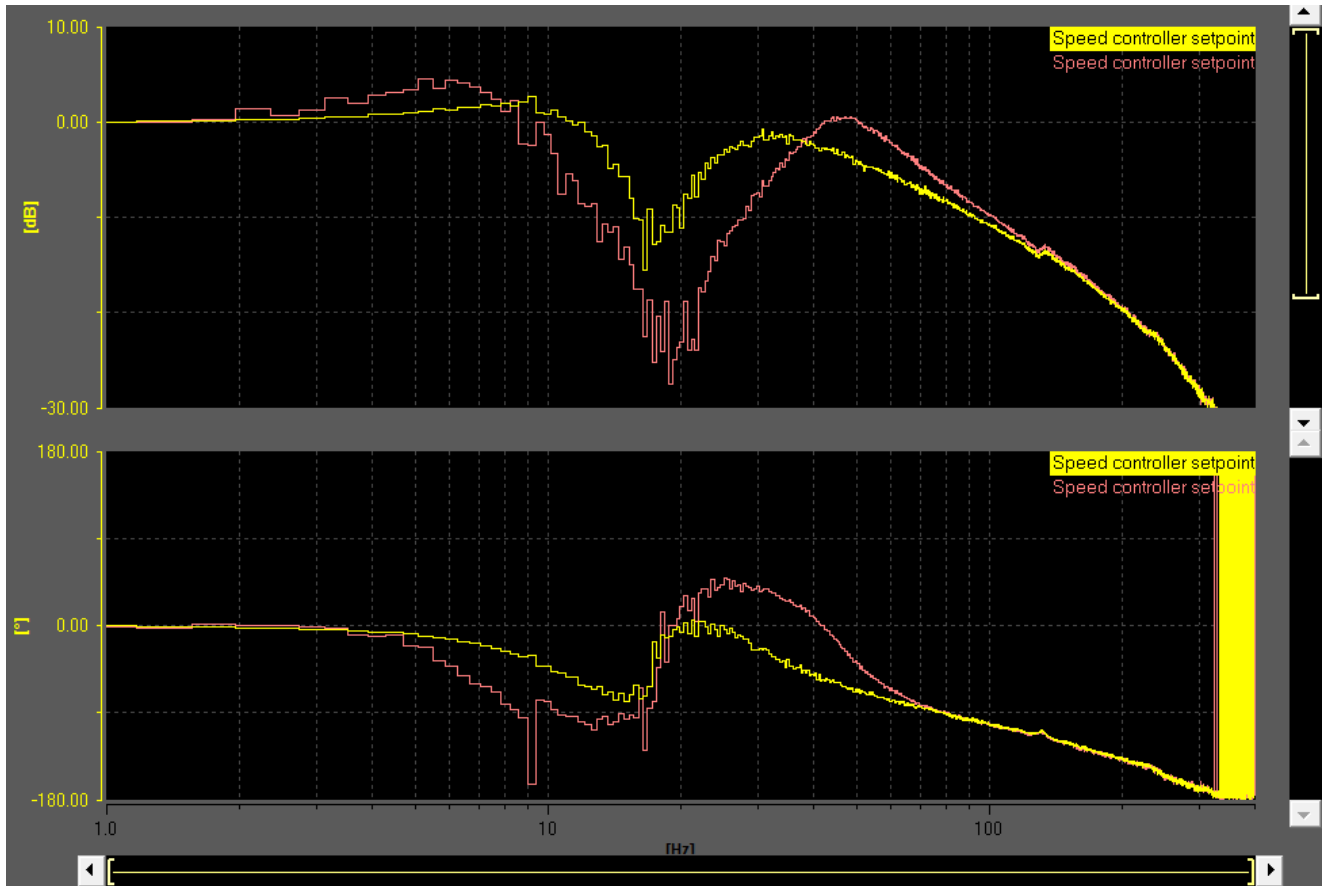

Yellow: Reference frequency response speed controller without differential position feedback
Red: Reference frequency response speed controller with differential position feedback

Figure 8-40 Differential position input, effect on the reference frequency response speed controller

As a result of the differential position feedback, the resonant position is shifted to a higher frequency. The damping effect of the speed controller is increased with the same controller gain.

8.14.5 APC with acceleration feedback

Description

Using this function, the acceleration signal from a direct measuring system is used to dampen oscillations.

Only oscillations that can be measured at the direct measuring system can be dampened. If this is not the case, then an external acceleration sensor can be mounted at a favorable location within the machine, and used for APC.

For instance, this function is well-suited for axes, where the oscillation only has a low effect on the motor (e.g. due to a high ratio - or significant self locking of a gearbox).

Frequently, when using a direct measuring system, high-frequency resonance points occur in the range > 100 Hz in the control loop, which can result in significant problems when setting APC. In cases such as these, the APC filter must be used in order to ensure control loop stability. It must also be taken into consideration that resonance effects such as these are dependent on axis positions, for example. The parameterization selected must be stable in the complete machining space of the machine. This is also the reason that using the function without a direct measuring system (see Chapter "APC without sensor on the load side (Page 562)") is frequently a more rugged solution.

Before the function can be optimized, the speed controller loop must first be optimized as this forms the subordinate control loop.

Function diagram (excerpt from function diagram 7012)

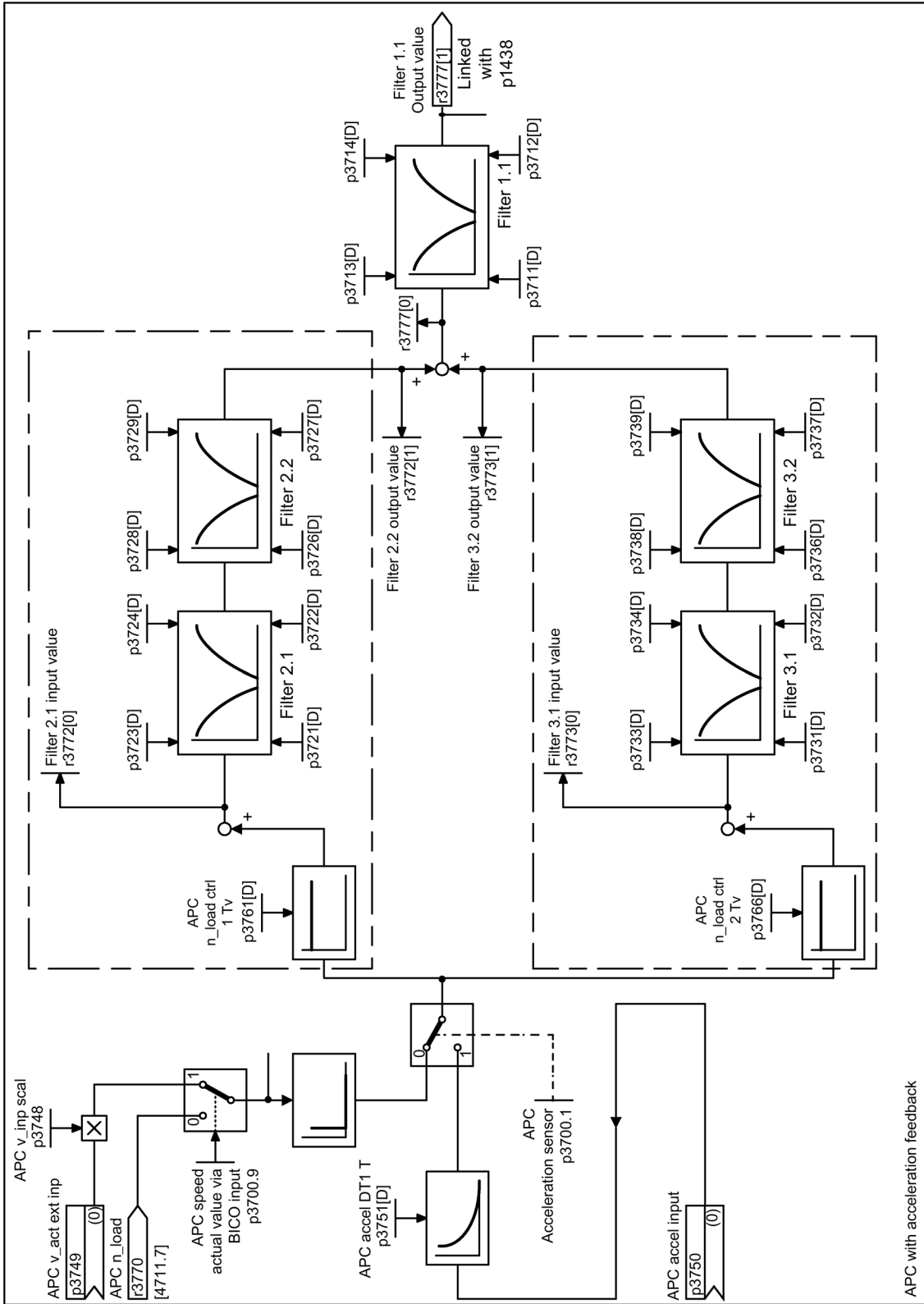

Important notes for parameterization

The function always requires a direct measuring system. If an axis is equipped with a measuring system (encoder 2 or encoder 3), then this can be selected using p3701. BICO sink p3749 can be activated by setting p3700.9 = 1. The load speed actual value can now be freely interconnected, e.g. from a master axis. Scaling can be set using p3748.

An external acceleration sensor can be used as direct measuring system. This must be integrated in the system (e.g. using TM31) - and connected with BICO sink p3750. To eliminate low-frequency disturbances from the measurement signal, a highpass filter can be parameterized using p3751. The acceleration sensor for APC is activated with p3700.1 = 1.

There are two feedback branches for this function. Each branch is parameterized using a gain factor (p3761 and p3766). Frequently, practical values for the gain lie in a range between 1 ms and 10 ms; however, this depends on the mechanical system of the axis.

Filters can be activated for both branches (see function diagram and Chapter "Additional information (Page 583)").

For applications where a high contour precision is required (in the mold making area) we recommend that p3700.3 is set = 1. As a consequence, the setpoint motion of the axis within APC is better taken into account.

Measuring the function

The following measuring functions can be used to measure the "APC with acceleration feedback" function:

- APC open circuit
- APC closed circuit
- Speed controller reference frequency response
- Position controller reference frequency response

You can find detailed information on how to perform these measurements in Chapter "Measuring frequency responses (Page 585)".

Examples:

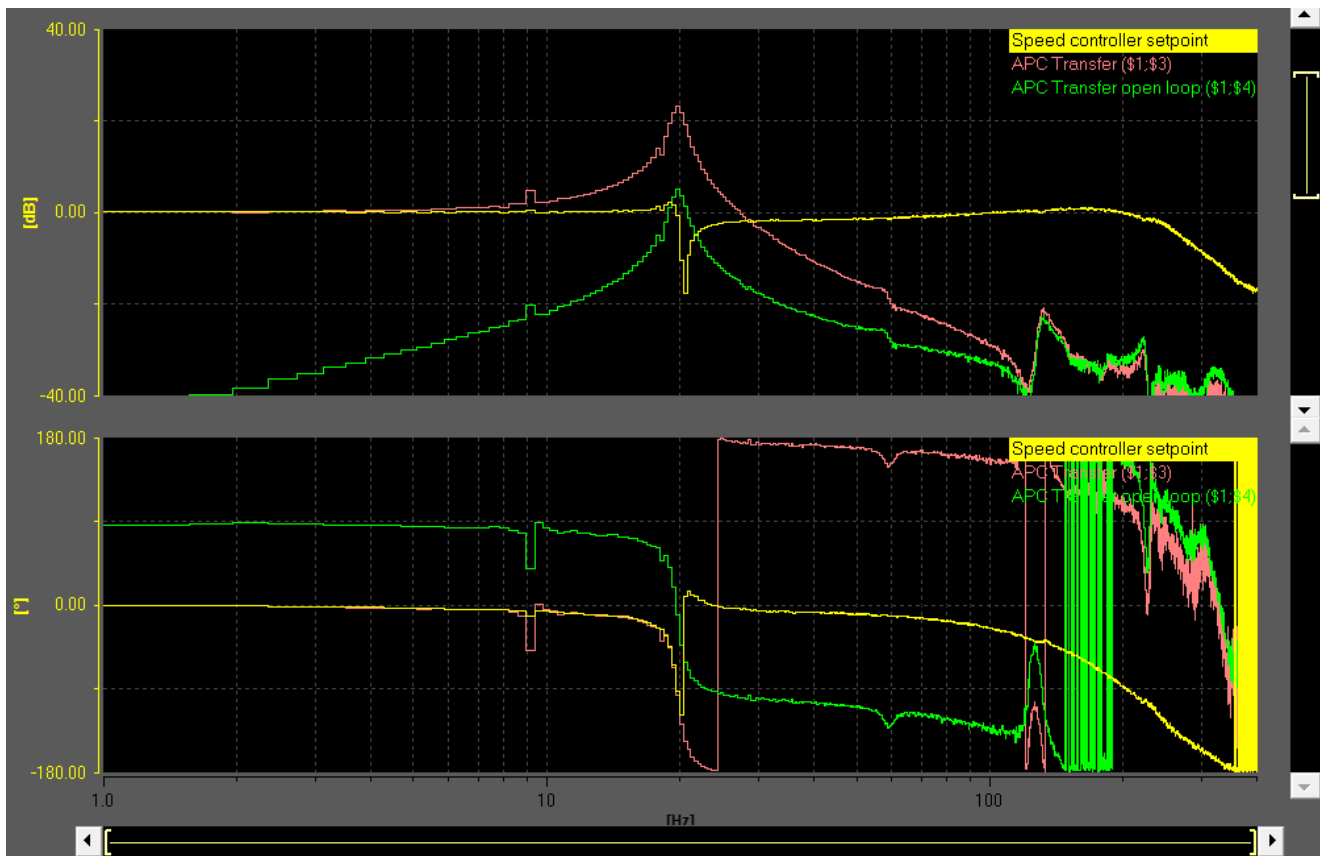

- Yellow Speed controller reference frequency response
- Magenta APC closed circuit (load speed/motor speed), measured with APC inactive
- Green APC open circuit (filter 1 output/motor speed), p3761 = 3 ms

Figure 8-41 APC circuit open

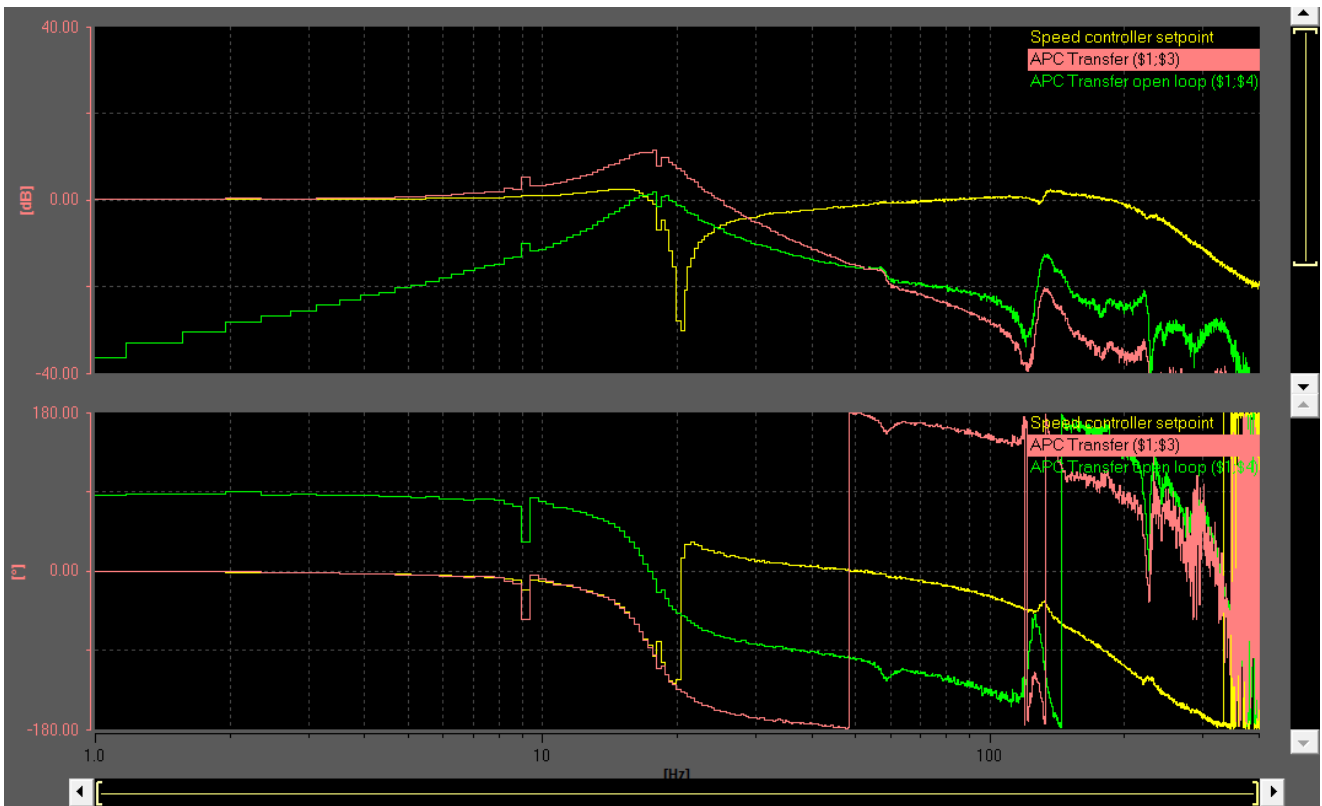

- Yellow Speed controller reference frequency response
- Magenta APC closed circuit (load speed/motor speed), $p_{3761} = 3 \text{ ms}$
- Green APC open circuit (filter 1 output/motor speed), measured with APC active

Figure 8-42 APC circuit closed

The following diagram shows, in the time domain, how APC with acceleration feedback acts on the motor and load velocity:

No damping

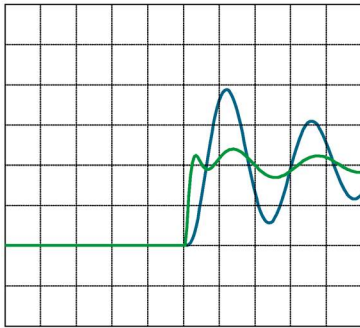

Blue Load speed
Green Motor speed

Load damping using APC:

Acceleration input

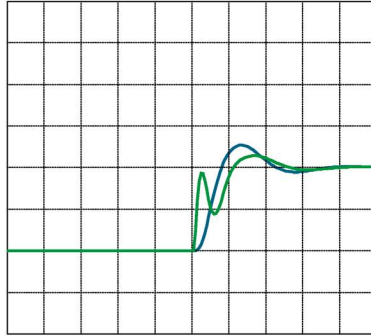

Figure 8-43 APC with acceleration input (example)

At the beginning, the motor must move more in order to combat oscillation.

Principle of operation of the two feedback loops

The following diagrams show the principle of operation of the two combined APC feedback loops:

- Block diagram

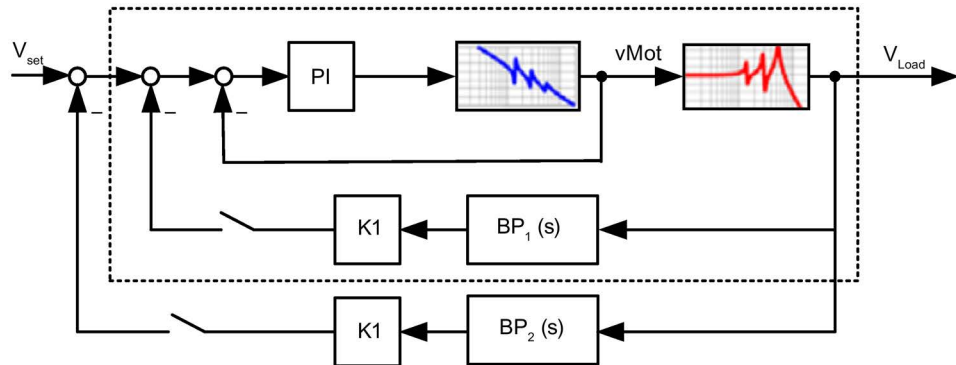

Figure 8-44 Control loop with two APC feedbacks

- Load frequency response without APC

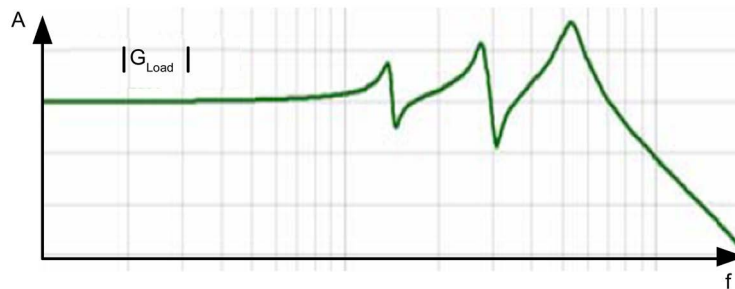
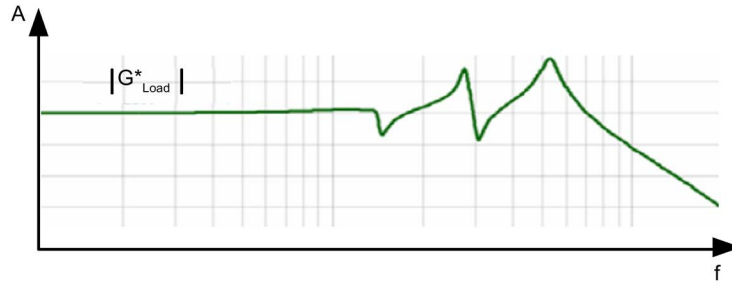
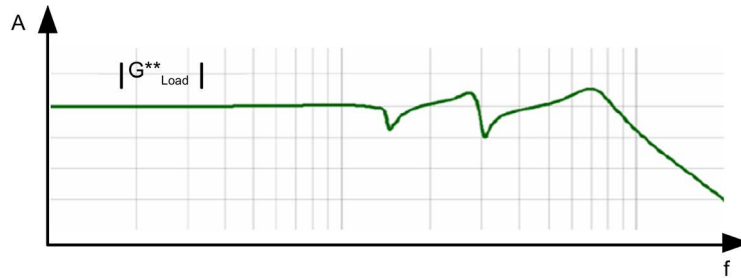

Figure 8-45 Sample load frequency response

- Load frequency response with APC: 1 feedback closed



- Load frequency response with APC: 2 feedbacks closed



8.14.6 APC with load velocity control

Description

With this function, a P control of the load velocity is implemented in parallel to normal speed control. The oscillation is shifted to higher frequencies and dampened.

The motor makes relatively significant compensating movements as a result of the function.

In its principle of operation, the function has a certain similarity to encoder combination.

It makes sense to use this function, especially together with functions "APC with acceleration feedback (Page 573)" or "APC without sensor on the load side (Page 562)".

Function diagram (excerpt from function diagram 7012)

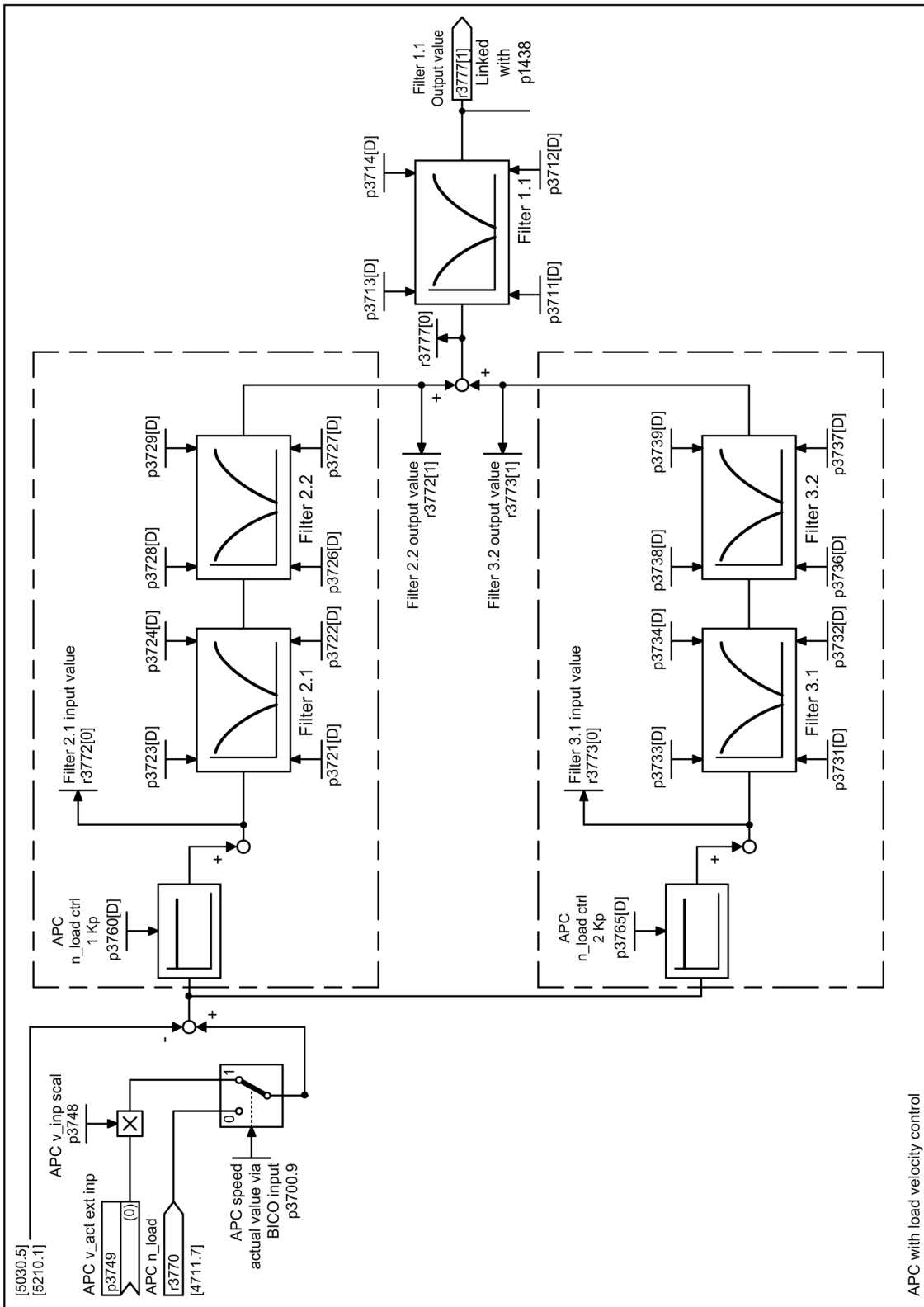

Important notes for parameterization

The function always requires a direct measuring system. If an axis is equipped with a measuring system (encoder 2 or encoder 3), then this can be selected using p3701. BICO sink p3749 can be activated by setting p3700.9 = 1. The load speed actual value can now be freely interconnected, e.g. from a master axis. Scaling can be set using p3748.

There are two feedback branches for this function. Each branch is parameterized using a gain factor (p3760 and p3765). Practical values for the gain generally lie between 0 and 1.

Filters can be activated for both branches (see function diagram and Chapter "Additional information (Page 583)").

Measuring the function

The following measuring functions can be used to measure the "APC load velocity control" functions:

- APC closed circuit
- Speed controller reference frequency response
- Position controller reference frequency response

You can find detailed information on how to perform these measurements in Chapter "Measuring frequency responses (Page 585)".

Example:

The following diagram shows, in the time domain, how APC with load velocity control acts on the motor and load velocity:

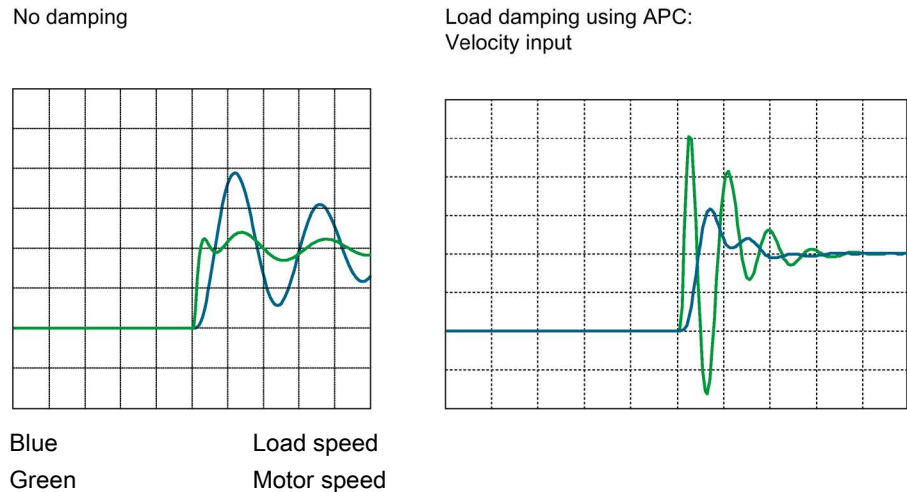

Figure 8-46 APC with speed input (example)

The motor speed with APC with speed input manifests a significant level of fluctuating loads, which can result in more significant stressing of the mechanical components. Oscillation frequency is increased.

8.14.7 Additional Information

Setting activation parameter p3700

The individual bits of the activation parameter have the following significance:

p3700 bit	Value	Significance
0	0	The value 0 is not applied to the speed setpoint. This setting must be used to measure the filter frequency responses.
	1	The acceleration filter output is applied to the speed setpoint. The differential position feedback is activated.
1	0	The actual encoder value selected with p3701 is used as the APC speed actual value.
	1	The source of p3750 is used as the APC acceleration actual value.
2	0	The actual encoder value selected with p3701 is used as the APC actual value.
	1	A model value without sensor is used as the APC actual value on the load side. PT1 filtering with p3709 acts as smoothing time and a highpass filter with p3751 as a highpass time constant. Bit 1 can be set but is not effective.
3	0	–
	1	The setpoint acceleration of the axis is taken into account in the APC calculation. This is especially relevant for applications that require a high contour accuracy. ¹⁾
8	0	–
	1	The speed from the direct measuring system selected for APC, weighted with p3702, and the motor speed are used as speed actual value for the speed control.
9	0	The actual encoder value selected with p3701 is used as the APC actual value.
	1	Instead of the selected encoder value, the source of p3749 weighted with p3748 is used. If bit 1 or bit 2 are simultaneously set, then they change the acceleration component (which goes through p3760/p3765) while the speed component (which goes through p3761/p3766) is still taken from BICO.

¹⁾ Additional dependencies when using bit 3:

- When using Sinumerik, DSC and precontrol should be active.
- When using EPOS/position control, the standard connection must be changed to:
 - r2560 (output position controller) interconnected with: p1160
 - r2561 (speed precontrol value) interconnected with: p1430
- The interpolator should be activated: p1400.7 = 1

APC filter

The filter is used to stabilize the control. For Sinumerik, in HMI Operate screen form-based support is provided using menu "Commissioning > Optimization/test > Active filter > Filter group ". In STARTER there is no screen form-based support for parameterizing the filter. This must be carried out in the Expert list.

- For each filter you can individually select as to whether it should be a general 2nd order filter - or a lowpass (PT2) filter (p3705).
- The transfer function can be found in Chapter "Current setpoint filter (Page 96)" under "Transfer function: general 2nd order filter". The structure of the APC filter is identical to that of the current setpoint filters.
- The parameters required to assign the filter parameters are shown in the function block diagram 7012.
- The filter subsampling is helpful for low filter frequencies (p3706 or p3707). Check the filter effect by analyzing the frequency response.

Observe the phase rotation as a result of filtering. The phase rotation may mean that there is not enough phase reserve for the APC control loop.

Dependency on the parameter set

Most APC parameters are dependent on DDS (you can find more detailed information on this topic, for example in the SINAMICS S120_S150_List_Manual). If a DDS switchover is parameterized, then the corresponding APC parameters must be copied into the data sets.

For the "APC without sensor on the load side" function, parameters p0341, p0342 and p1498 are used to calculate to the moment of inertia. Parameters p0341 and p0342 are dependent on the motor data set. Parameter p1498 is dependent on DDS. These parameters can be used to emulate, for example, different load states of the axis for different APC settings.

Activation parameter p3700 is not dependent on any parameter set. The configuration of APC acts the same on all data sets.

The BICO sink for the acceleration sensor (p3750) and for the velocity actual value (p3749) are dependent on CDS. If CDS data sets have been created, then these two parameters must be appropriately handled.

APC applied to master-slave axes

With axes, which form a master-slave group with several drives, generally only 1 direct measuring system is integrated, which is generally assigned to the master. If APC is to be used with an axis such as this, using a direct measuring system, then frequently the effect is not sufficient when only the master is parameterized. By using BICO to connect the speed actual value, then also the slave drives can be parameterized with APC and the effectiveness of the function is increased. To do this, the slave drives must be parameterized as follows:

- p3700.9 = 1
- p3749 = Master.r3771[0]
- p3748: The scaling must be appropriately set.

When doing this, different gearbox ratios, different direction rotation, and if the motors used for the master and slave have different rated speeds, the ratio of the scaling parameters p2000 must be taken into account.

Miscellaneous

In this document, APC has been subdivided into 4 main subfunctions. In principle, APC allows (almost) any combination of these subfunctions. In the document reference was made to constellations where such a combination can make sense.

It is recommended that the Kp/Tn adaptation of the speed controller is deactivated (p1400.5 = 0), as the speed controller acts as subordinate control loop to the APC control loop.

8.14.8 Measuring frequency responses

This chapter describes which measuring functions are available to measure the relevant frequency responses, and how these can be executed.

Are you As APC has its own control loop, it is always recommended, when starting optimization, to measure the open circuit once with a high bandwidth (e.g. 4000 Hz for a speed controller clock cycle of 125 μ s). This measurement can be used as basis to derive whether and which filtering is required to stabilize the control loop. This is especially important for APC using a direct measuring system.

However, to optimize APC further it is better to perform the measurements with a lower bandwidth (e.g. 400 Hz - the lower the oscillation frequency, the lower the measurement bandwidth), as the frequency resolution of the measurement increases.

Application involving Sinumerik

There are several predefined measurement functions in HMI Operate to measure APC control loops. Measurement functions "APC open circuit" and "APC closed circuit" are available in the menu "Commissioning > Optimization/test > Speed control loop".

Note

These measurement functions are only displayed if a value > 0 is entered in the parameter p3761! When activated for the first time, APC should still be inactive (p3700.0 = 0).

The encoder combination function can be measured using predefined measurement functions "Speed-controlled system", "Open speed control loop" or "Speed controller reference frequency response". The differential position feedback function can be measured using "Open speed control loop" or "Speed controller reference frequency response".

All APC functions can be measured at the reference frequency response of the position control loop (in menu "Commissioning > Optimization/test > Position control loop" select measurement "Position controller reference frequency response").

Application with STARTER

In STARTER there are **no** predefined measurement functions to measure the relevant frequency responses of APC.

However, for the predefined measurement functions, you have the option of recording 2 additional signals. Using mathematical functions, you can display the required frequency responses as Bode diagram.

1. Select the measurement function and the additional signals.

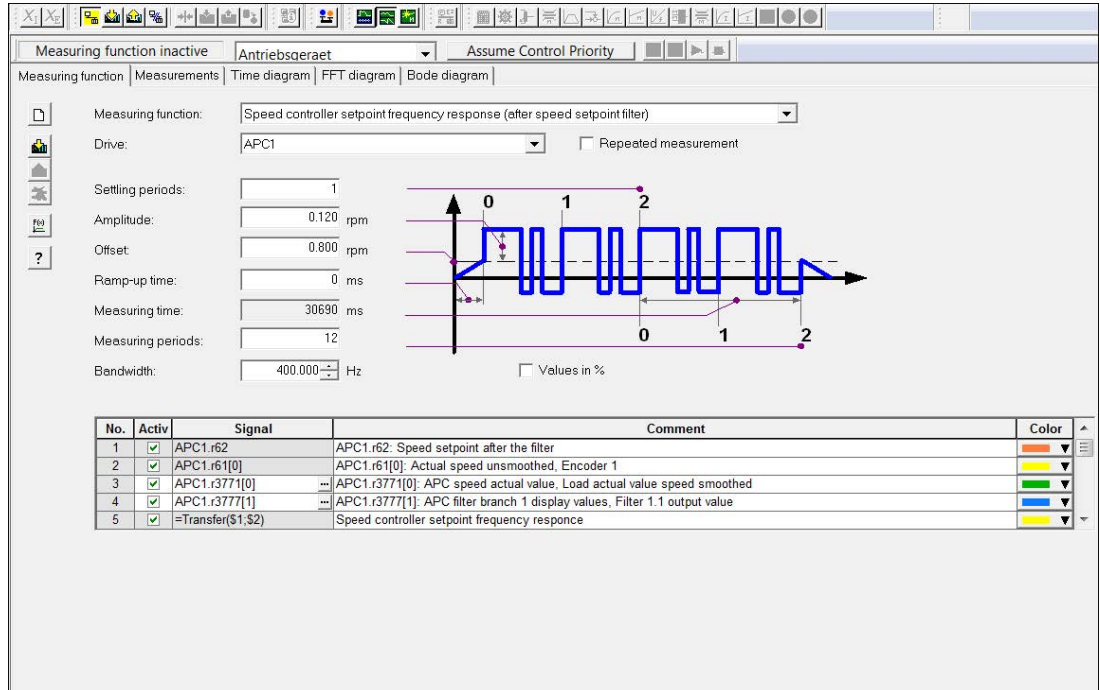

Figure 8-47 Measurement functions and signals

2. Define the transfer functions.

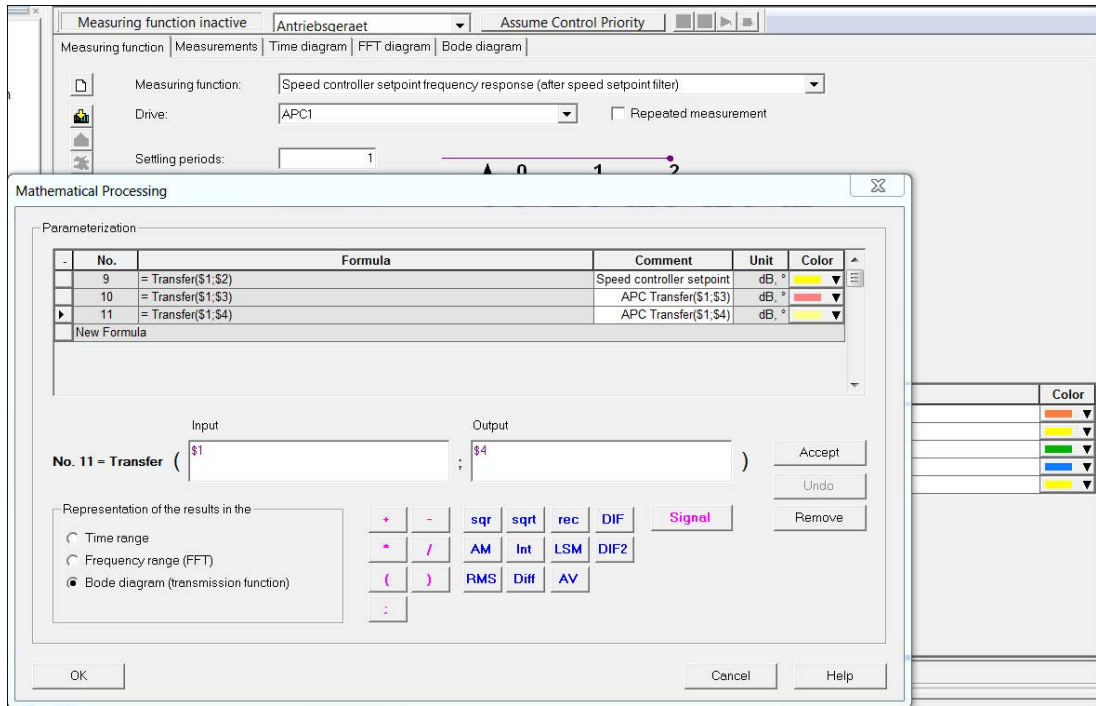

Figure 8-48 Transfer functions

Definition of the measuring functions

Measuring function	Configuration
APC open circuit	<ol style="list-style-type: none"> As measuring function select "Speed controller reference frequency response" Add signal r3777[1] "APC output value" to the measuring signals. Set the mathematical function: Bode diagram > Input: r62, output: r3777[1] <p>Note: To measure the open circuit, p3761 must be assigned a low derivative action time, e.g. p3761 = 1 ms. APC should be deactivated (p3700.0 = 0).</p>
APC closed circuit	<ol style="list-style-type: none"> The closed circuit can only be measured if a direct measuring system is available. As measuring function select "Speed controller reference frequency response" Add signal r3771[0] "APC load speed actual value" to the measuring signals. Set the mathematical function: Bode diagram > Input: r62, output: r3771[0].
Measuring the encoder combination using the speed control loop	<ol style="list-style-type: none"> As measuring function select "Speed-controlled system" Add signal r1445 "Actual speed smoothed" to the measuring signals. Set the mathematical function: Bode diagram > Input: r80, output: r1445
Measure encoder combination and differential position feedback using the speed controller reference frequency response	<ol style="list-style-type: none"> As measuring function select "Speed controller reference frequency response" Add signal r1445 "Actual speed smoothed" to the measuring signals. Set the mathematical function: Bode diagram > Input: r62, output: r1445
Measuring position controller reference frequency response	<p>Requirement: The position controller function module is activated.</p> <ol style="list-style-type: none"> As measuring function, select "Free measuring function (without master control)" Connect the function generator output CU.r4834[0] to a free speed setpoint (e.g. p1155 or p1430) Add measuring signals: CU.r4834[0] and r2560 "LR speed setpoint" Set the mathematical function: Bode diagram > Input: r4834[0] * p2000/100, output: r2560*(-1) Factor p2000/100 maps the function generator scaling to the speed. Traverse the axis, for example from an HMI device or the operator panel, with a low velocity (position controller must be active!). Start the measurement while the axis traverses. After the measurement has been completed, the function generator connection to the speed setpoint should be removed (manually)

8.14.9 Function diagrams and parameters

Function diagrams (see SINAMICS S120/S150 List Manual)

- 5030 Servo control - Reference model/precontrol balancing/speed limiting
- 5210 Servo control - Speed controller without encoder
- 7012 Technology functions – Advanced Positioning Control
- 7013 Technology functions – Advanced Positioning Control differential position amplification

Overview of important parameters (see SINAMICS S120/S150 List Manual)

- p0341[0...n] Motor moment of inertia
- p0342[0...n] Ratio between the total and motor moment of inertia
- p1498[0...n] Load mass
- p3700 APC configuration
- p3701 APC encoder selection
- p3702[0...n] APC load speed/motor speed weighting
- p3704[0...n] APC filter activation
- p3705[0...n] APC filter type
- p3706[0...n] Advanced positioning control undersampling filter 2.x
- p3707[0...n] Advanced positioning control undersampling filter 3.x
- p3708[0...n] Advanced Positioning Control actual speed value smoothing time encoder 2
- p3709[0...n] Advanced Positioning Control actual speed value smoothing time encoder 3
- p3711[0...n] Advanced Positioning Control filter 1.1 denominator natural frequency
- p3712[0...n] Advanced Positioning Control filter 1.1 denominator damping
- p3713[0...n] Advanced Positioning Control filter 1.1 counter natural frequency
- p3714[0...n] Advanced Positioning Control filter 1.1 counter damping
- p3721[0...n] Advanced Positioning Control filter 2.1 denominator natural frequency
- p3722[0...n] Advanced Positioning Control filter 2.1 denominator damping
- p3723[0...n] Advanced Positioning Control filter 2.1 counter natural frequency
- p3724[0...n] Advanced Positioning Control filter 2.1 counter damping
- p3726[0...n] Advanced Positioning Control filter 2.2 denominator natural frequency
- p3727[0...n] Advanced Positioning Control filter 2.2 denominator damping
- p3728[0...n] Advanced Positioning Control filter 2.2 counter natural frequency

- p3729[0...n] Advanced Positioning Control filter 2.2 counter damping
- p3731[0...n] Advanced Positioning Control filter 3.1 denominator natural frequency
- p3732[0...n] Advanced Positioning Control filter 3.1 denominator damping
- p3733[0...n] Advanced Positioning Control filter 3.1 counter natural frequency
- p3734[0...n] Advanced Positioning Control filter 3.1 counter damping
- p3736[0...n] Advanced Positioning Control filter 3.2 denominator natural frequency
- p3737[0...n] Advanced Positioning Control filter 3.2 denominator damping
- p3738[0...n] Advanced Positioning Control filter 3.2 counter natural frequency
- p3739[0...n] Advanced Positioning Control filter 3.2 counter damping
- p3748[0...n] APC velocity input scaling
- p3749[0...n] CI: APC velocity actual value external input
- p3750[0...n] CI: Advanced Positioning Control acceleration sensor input
- p3751[0...n] Advanced Positioning Control acceleration sensor high-pass time constant
- p3752[0...n] APC controller preassignment natural oscillation frequency
- p3760[0...n] Advanced Positioning Control load speed controller 1 P gain
- p3761[0...n] Advanced Positioning Control load speed controller 1 derivative-action time
- p3765[0...n] Advanced Positioning Control load speed controller 2 P gain
- p3766[0...n] Advanced Positioning Control load speed controller 2 derivative-action time
- p3767[0...n] Advanced Positioning Control differential position time constant
- p3768[0...n] Advanced Positioning Control differential position amplification factor
- r3769 CO: Advanced Positioning Control differential position force setpoint
- r3770 CO: Advanced Positioning Control load speed
- r3771[0...1] CO: Advanced Positioning Control actual velocity value
- r3772[0...1] Advanced Positioning Control filter branch 2 display values
- r3773[0...1] Advanced Positioning Control filter branch 3 display values
- r3777[0...1] CO: Advanced Positioning Control filter branch 1 display values
- p3778[0...n] Advanced Positioning Control speed limit
- p3779[0...n] Advanced Positioning Control speed limit monitoring time

8.15 Cogging torque compensation

8.15.1 Overview

For synchronous motors, the cogging torque can be compensated to improve radial eccentricity as there is a fixed connection between the absolute location and cogging force in these motors. Induction motors are not suitable for cogging torque compensation.

The entire cogging torque compensation is executed via a compensation table which, depending on the position of the motor measuring system, is read out and precontrolled. The cogging torque compensation can also be performed based on the direction. For this reason, a separate table can be used for the compensation for each direction of motion (p5260, p5261).

The tables for the cogging torque compensation must be filled out using a “Learning process”. During this learning process, the cogging torque can be measured when moving the motor and stored in the table. If you want to use direction-based cogging torque compensation, you have to perform corresponding learn runs for each direction of motion.

This function module is only available for the SERVO drive object.

Restrictions

- A motor encoder is always required for the cogging torque compensation.
- Transistor-transistor logic or HTL encoders are not suitable for cogging torque compensation.
- The encoder must have absolute information, thus it must be an absolute value encoder or have a clear zero mark or be distance-coded. Due to the premature validity message of absolute information, DQI encoders are only suitable with a bypass (Encoder Data Set switchover after start-up).
SINAMICS encoder evaluations with actual hardware required (SMC 10/20, SME12x, ≥ 6SL xxxx-xxxx-xxx3) and SINAMICS firmware > 04.50.22).
- The compensation is then applied to the torque-generating current setpoint. It is only effective if neither current nor voltage limiting intervenes and the frequency is not higher than the current controller bandwidth.

8.15.2 Commissioning

Activate cogging torque compensation function module

1. Activate the “Cogging torque compensation” function module using the commissioning Wizards in the STARTER.
- OR -
2. Open the configuration of the drive unit (“Configuration” > “Function module / Technology package”) and activate the option “Cogging torque compensation” in the dialog “Object properties”.

You can check that it has been activated in parameter r0108.22.

Activate cogging torque compensation

1. To activate cogging torque compensation, set p5250.0 to 1.

With this setting, only a table independent of the direction of motion is used for the cogging torque compensation (p5260).

2. If you want to use your own table for each motion direction of the Cogging torque compensation, also set p5250.1 to 1.

With this setting, each direction of motion uses its own table.

The compensation values are stored in p5260 (positive direction) and p5261 (negative direction).

Note

If this option is activated, **no** additional learning is possible (p5251.1 = 1).

If you deactivate this option with p5250.1 = 0, table p5260 is once again used for both directions.

8.15.3 Filling compensation tables

Cogging torque compensation is executed via a table p5260 which, depending on the position of the motor measuring system, is read out and precontrolled. The table is entered in Nm for rotating motors or in N for linear motors.

Configure settings to fill the compensation tables.

The following parameter settings are important when filling the compensation tables:

Parameter	Bit	Index	Value	Significance
p5251	0	-	1	<p>Activate the option "New slow learning" By activating the option, the corresponding compensation table is deleted with the learning process. During the learning process, the cogging torque compensation is automatically deactivated.</p> <p>So that the acceleration torque does not distort the results, this option may only be activated after the normal speed is reached.</p> <p>With slow learning, the motor must be operated at a very low speed (1.5⁻¹) or velocity (0.1 m/min). During the learning run, the cogging torque can be measured when moving the motor and stored in the table.</p> <p>Additional values are averaged when passing through several periods. The number of average periods can be viewed in r5254[0], the actual table index in r5254[1]. The table is only completely filled when r5254[0] ≥ 2.</p>
	1	-	1	<p>Activate the option "Supplementary slow learning". This setting is used to fill the compensation table in several steps across multiple learning processes. This is required, for example, with a linear motor. During the learning process, the cogging torque compensation is automatically deactivated. This supplementary learning is only possible for non-direction-based cogging torque compensation (p5250.1 = 0).</p> <p>During supplementary learning, gaps in the table are filled in. Where there were previously already values in the table and new values are measured due to overlapping, an average is used (old value/new value).</p> <p>An overlap is necessary for supplementary learning. Without overlap, the values of the supplementary learning are rejected, and only the values from the 1st learning operation are kept.</p>
	0.1	-	0	Shuts down the slow learning. Following this, the mean value of the measured values in the table is determined and removed.
	2	-	1	Removes the mean value of a compensation table. This setting is required if compensation values calculated through learning must be manually corrected at the start/end of the compensation table. The values in the table to be corrected must be deleted from the range at the edge of the table!
p5252	-	-	n	<p>Used to define the length of a compensation table. When specifying the length, only powers of two are permitted (2^{p5252}). To achieve a sensible compensation (for linear motor), at least 10 compensation values are required for each pole.</p> <ul style="list-style-type: none"> Example: linear motor: p0315 = 30 mm, traversing distance = 1500 mm. As a consequence, this results in p5252 ≥ 1024 values.

Parameter	Bit	Index	Value	Significance
p5253	-	-	n	<p>Sets the factor for the search velocity for the periodicity during cogging torque compensation.</p> <ul style="list-style-type: none"> For rotating motors, the factor refers to one mechanical revolution (p5253 = 0.5 then generates one period of half of one mechanical revolution). For linear motors, the factor refers to one pole pair width. For synchronous motors, you should select the complete traversing range as period (i.e. p5253 = traversing distance [mm] / p0315). The motor measuring system must have absolute information here, which is unique regarding the period; whereby an overflow in the actual value representation can destroy this uniqueness.
r5254	-	0	n	Shows the mean values per point in the table during slow learning. If a point in the table is passing through several times during slow learning, the newly calculated torques are taken into account under the mean value. The table value is corrected accordingly.
	-	1	n	Shows the currently used table index if the cogging torque compensation or a learn process is active.
	-	2	n	Shows the table index at the start of the slow learning.
	-	3	n	Shows the table index at the end of the slow learning.
r5255	-	0	n (Nm or N)	<p>Cogging torque compensation input</p> <p>Shows the actual torque/actual force when learning</p>
	-	1	n (Nm or N)	<p>Cogging torque compensation output</p> <p>Shows the precontrolled actual torque/actual force.</p>
p5256	-	-	n (rpm or m/min)	Used to switch between the two compensation tables (where p5250.1 = 1) for direction reversal in order to prevent frequent switching between the two tables in the case of actual speed value noise at standstill. In the hysteresis range, the respective previous table remains active. The hysteresis width should be slightly larger than the actual speed value noise at standstill.
p5260	-	0...4095	n (Nm or N)	<p>Compensation values for the cogging torque compensation. These compensation values are filled through a learning process (p5251) and can be changed manually.</p> <ul style="list-style-type: none"> Given a non-direction-based cogging torque compensation (p5250.1 = 0) only this table is used. Given a direction-based cogging torque compensation (p5250.1 = 1) this table is used for the positive direction of motion only. <p>After replacing the encoder and/or motor, the values in the compensation table must be relearned.</p>
p5261	-	0...4095	n (Nm or N)	<p>Compensation values for the cogging torque compensation in the negative direction of motion (p5250.1 = 1). These compensation values are filled through a learning process (p5251) and can be changed manually.</p> <p>After replacing the encoder and/or motor, the values in the compensation table must be relearned.</p>

8.15.4 Examples

Slow supplementary Learning in a linear motor

For linear motors you cannot measure the complete traversing distance in one operation. The motor must first be accelerated up to its learning velocity and then learning is activated. For this reason, it is advisable to measure the traversing distance in several steps.

1. After the motor has reached the desired speed, (re)activate the slow learning with $p5251.0 = 1$.
2. End the slow learning after you have traveled from the right third to the left edge of the traversing distance with $p5251.0 = 0$.

The compensation table is now partly filled with values.

3. At the end of this 1st learning, check the table indices determined from $r5254[2]$ (start value) and $r5254[3]$ (final value).
 - If the start value is higher than the final value, the values are learned from the start value up to the end of the table and from 0 up to the final value.
 - If the start value is less than the final value, then the values are learned from the start value up to the final value. This also applies if the table progress when learning is negative. In this particular case, the start value and final value are interchanged after learning.
4. A further learning process is required for the missing part of the compensation table. In this example, measure in the opposite direction from the left third of the traversing distance to the right edge. Ensure that the 2nd learning run overlaps with the 1st learning run previously conducted, otherwise the measurement will be rejected.

Start the supplementary learning after the desired speed is reached with $p5251.1 = 1$.

5. After the end of the 2nd learning run, exit the supplementary learning with $p5251.1 = 0$.

The newly calculated values in the compensation table are brought on to the same level. Overlapping ranges are averaged, the non-overlapping ranges supplemented and the mean value removed.

6. If the linear motor has reached the stop, large torques are stored in the table.

In this case, delete the high torques and from the edge and then remove the mean values with $p5251.2 = 1$.
7. Activate the cogging torque compensation with $p5250.0 = 1$ if this has not already been done.

The cogging torque compensation is then performed with the values from $p5260$.

8. So that the values in the compensation table are permanently stored, perform a RAM to ROM.

If they are not saved, the values in the compensation table need to be recalculated after each POWER ON.

Filling process depending on the direction of motion

Compensation depending on the direction of motion is beneficial when the operating point changes depending on the direction of motion given large friction forces.

1. So that a compensation table is used for each direction of motion, activate p5250.1 = 1 (prerequisite: p5250.0 = 1).
2. Define the length of the compensation table using p5252.
3. Move the motor with 1.5 revolutions per minute (in positive direction).
4. Activate slow learning for the compensation table of this direction of motion with p5251.0 = 1.

The compensation table p5260 is filled.

5. Check the mean values for slow learning.

Wait at least one revolution of the motor. As soon as the mean values (r5254[0]) are ≥ 2 , the slow learning can be exited.

6. Then Deactivate slow learning for the positive direction with p5251.0 = 0.
7. Move the motor with -1.5 revolutions per minute (in negative direction).

8. Activate slow learning for the compensation table of this direction of motion with p5251.0 = 1.

The compensation table p5261 is filled.

9. Check the mean values for slow learning.

Wait at least one revolution of the motor. As soon as the mean values (r5254[0]) are ≥ 2 , the slow learning can be exited.

10. Then Deactivate slow learning for the negative direction with p5251.0 = 0.

The cogging torque compensation is then performed with the values from p5260 and p5261.

11. So that the values in the compensation table(s) are permanently stored, perform a RAM to ROM.

If they are not saved, the values in the compensation table need to be recalculated after each POWER ON.

Note

If the cogging torque compensation is active during slow learning, the compensation tables are switched with the rotational speed hysteresis (p5256). The respective prior table remains active as long as the rotational speed remains in the hysteresis band. A table switch can only take place when the hysteresis range is left.

8.15.5 Messages and parameters

Faults and alarms (see SINAMICS S120/S150 List Manual)

A07354 Drive: Cogging torque compensation not possible

Overview of important parameters (see SINAMICS S120/S150 List Manual)

- r0108 Drive object function module
- p5250[0...n] Cogging torque compensation configuration
- p5251 Activate cogging torque compensation learning
- p5252 Cogging torque compensation table length
- p5253 Cogging torque compensation periodicity (intermittency) factor
- r5254[0...3] Cogging torque compensation diagnostics
- r5255[0...1] CO: Cogging torque compensation input/output
- p5256[0...n] Cogging torque compensation direction reversal hysteresis
- p5260[0...4095] Cogging torque compensation table
- p5261[0...4095] Cogging torque compensation table negative direction

Monitoring functions and protective functions

9.1 Power unit protection, general

SINAMICS power units offer comprehensive functions for protecting power components.

Table 9- 1 General protection for power units

Protection against:	Precautions	Responses
Overcurrent ¹⁾	Monitoring with 2 thresholds: <ul style="list-style-type: none"> 1. Threshold exceeded 	A30031, A30032, A30033 Current limiting of a phase has responded. The pulsing in the phase involved is inhibited. If it is too frequently exceeded F30017 → OFF2
	<ul style="list-style-type: none"> 2. Threshold exceeded 	F30001 "Overcurrent" → OFF2
Overvoltage ¹⁾	Comparison of DC-link voltage with hardware shutdown threshold	F30002 "Overvoltage" → OFF2
Undervoltage ¹⁾	Comparison of DC-link voltage with hardware shutdown threshold	F30003 "Undervoltage" → OFF2
Short-circuit ¹⁾	<ul style="list-style-type: none"> 2. Monitoring threshold checked for over-current 	F30001 "Overcurrent" → OFF2
	<ul style="list-style-type: none"> Uce monitoring of IGBT modules (chassis only) 	F30022 "Uce monitoring" → OFF2 (chassis only)
Ground fault	Monitoring the sum of all phase currents	After threshold in p0287 is exceeded: F30021 "Power unit: Ground fault" → OFF2 Note: The sum of all phase currents is displayed in r0069[6]. For operation, the value in p0287[1] must be greater than the sum of the phase currents when the insulation is intact.
Line phase-failure detection ¹⁾		F30011 "Line phase-failure in main circuit" → OFF2

¹⁾ The monitoring thresholds are permanently defined in the converter and cannot be changed.

9.2 Thermal monitoring and overload responses

The thermal power unit monitor is responsible for identifying critical situations. If alarm thresholds are exceeded, the user can set parameterizable response options that enable continued operation (e.g. with reduced power) and prevent immediate shutdown. The parameterization options, however, only enable intervention below the shutdown thresholds, which cannot be changed by the user.

The following thermal monitoring functions are active:

- I²t monitoring - A07805 - F30005

I²t monitoring is used to protect components that have a high thermal time constant compared with semiconductors. An overload with regard to I²t is present when the converter load r0036 is greater than 100% (load in % in relation to rated operation).

- Heat-sink temperature - A05000 - F30004

Is used to monitor the temperature r0037.0 of the heat sink on the power semiconductors (IGBT).

- Chip temperature - A05001 - F30025

Significant temperature differences can occur between the IGBT barrier junction and the heat sink. The calculated barrier junction temperature is displayed in r0037[13...18]; the monitoring ensures that the specified maximum barrier junction temperature is not exceeded.

If an overload occurs with respect to any of these three monitoring functions, an alarm is first output. The alarm threshold p0294 (I²t monitoring) can be parameterized relative to the shutdown (trip) values.

Example

The temperature difference between two sensors must not exceed more than 15 Kelvin (K); a temperature difference of 5 K is set for the temperature monitoring of the heat sink and the air intake. This means that 15 K or 5 K below the shutdown threshold an alarm is issued regarding the pending overtemperature. Using p0294, it is only possible to change the alarm threshold so that an alarm is received earlier. This means that an intervention can then be made in the drive process (e.g. reduce the load, reduce the ambient temperature).

Overload responses

The power unit responds with alarm A07805. The Control Unit initiates the parameterized responses via p0290 at the same time that the alarm is issued. Possible responses include:

- Reducing the pulse frequency (p0290 = 2, 3)

This is a highly effective method of reducing losses in the power unit, since switching losses account for a high proportion of the total losses. In many applications, a temporary reduction in pulse frequency is tolerable in order to maintain the process.

Disadvantage:

Reducing the pulse frequency increases the current ripple which, in turn, can increase the torque ripple on the motor shaft (with low inertia load), thereby increasing the noise level. Reducing the pulse frequency does not affect the dynamic response of the current control circuit, since the sampling time for the current control circuit remains constant.

- Reducing the output current (p0290 = 0, 2)

This variant is recommended when you do not need to reduce the pulse frequency or the pulse frequency has already been set to the lowest level. Further, the load should also have a characteristic similar to the fan, that is, a quadratic torque characteristic with falling speed. Reducing the converter output current reduces the losses in the power unit.

- No reduction (p0290 = 1)

You should choose this option if it is neither possible to reduce the pulse frequency nor reduce the output current. The converter does not change its operating point once an alarm threshold has been overshoot, which means that the drive can be operated until it reaches its shutdown values. Once it reaches its shutdown threshold, the converter switches itself off with alarm A05000 (power unit: Overtemperature inverter heat sink), A05001 (power unit: Overtemperature chip) or A07805 (drive: Power unit overload I2t). The time until shutdown, however, is not defined and depends on the degree of overload.

Function diagrams (see SINAMICS S120/S150 List Manual)

- 8021 Signals and monitoring functions - thermal monitoring power unit

Overview of important parameters (see SINAMICS S120/S150 List Manual)

- r0036 CO: Power unit overload I2t
- r0037[0...19] CO: Power unit temperatures
- p0290 Power unit overload response
- p0294 Power Module warning I2t overload

9.3 Blocking protection

The "Motor blocked" fault is only output if the speed of the drive is below the adjustable speed threshold (p2175). With vector control, it must also be ensured that the speed controller is at the limit. With V/f control, the current limit must already have been reached.

Once the on delay (p2177) has elapsed, the message "Motor blocked" and fault F07900 are generated.

The enable for blocked motor monitoring can be deactivated using p2144.

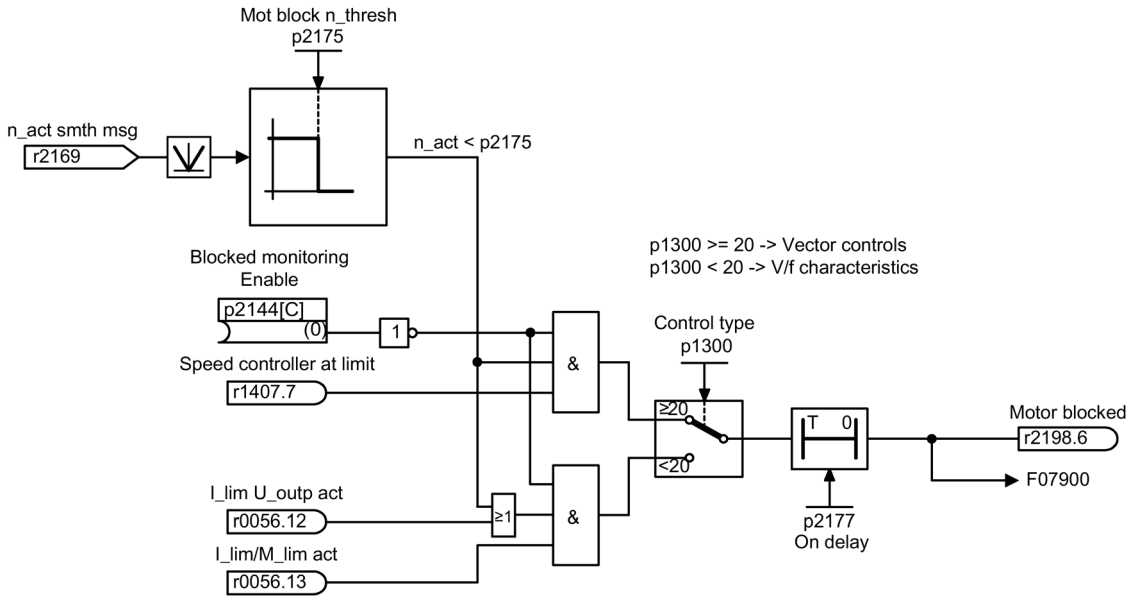

Figure 9-1 Blocking protection

Function diagrams (see SINAMICS S120/S150 List Manual)

- 8012 Signals and monitoring functions - Torque messages, motor locked/stalled

Overview of important parameters (see SINAMICS S120/S150 List Manual)

- p2144[0...n] BI: Blocked motor monitoring enable (negated)
- p2175[0...n] Motor locked speed threshold
- p2177[0...n] Motor locked delay time

9.4 Stall protection (vector control only)

If the adaptation controller output exceeds the speed threshold set in p1744 for stall detection, then r1408.11 (speed adaptation, speed deviation) is set.

If the error threshold value set in p1745 is exceeded when in the low speed range (less than p1755 x (100% - p1756)), r1408.12 (motor stalled) is set.

If one of the two signals is set, then after the delay time in p2178, fault F7902 (motor stalled) is output.

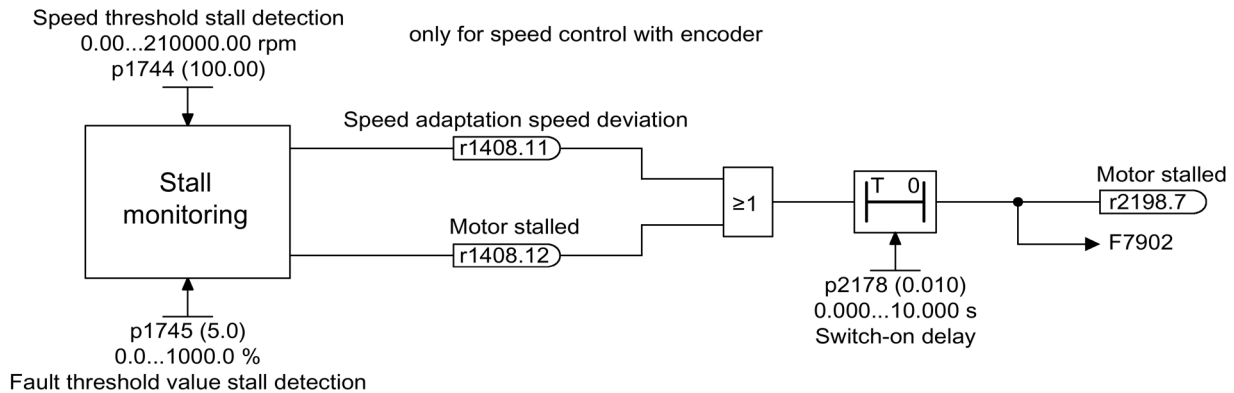

Figure 9-2 Stall protection

Function diagrams (see SINAMICS S120/S150 List Manual)

- 6730 Vector control - Interface to Motor Module (ASM, p0300 = 1)
- 8012 Signals and monitoring functions - Torque messages, motor locked/stalled

Overview of important parameters (see SINAMICS S120/S150 List Manual)

- r1408.0...15 CO/BO: Status word, current controller
- p1744[0...n] Motor model speed threshold stall detection
- p1745[0...n] Motor model error threshold stall detection
- p1755[0...n] Motor model changeover speed encoderless operation
- p1756 Motor model changeover speed encoderless operation
- p2178[0...n] Motor stalled delay time

9.5 Thermal motor protection

The thermal motor protection monitors the motor temperature and responds to overtemperature conditions with alarms or faults. The motor temperature is either measured with sensors in the motor, or is calculated without sensors, using a temperature model from the operating data of the motor. Combinations of temperature measurement and taking into consideration a motor temperature model are possible. As soon as critical motor temperatures are determined, measures to protect the motor are initiated.

For thermal motor protection with temperature sensors, the motor temperature is directly measured in the motor windings. The temperature sensors are either connected to the Control Unit, the Motor Module or supplementary modules. The determined temperature values are sent to the Control Unit, which then responds according to the parameter settings. When switching on again after a power failure, the actual motor temperatures are immediately available.

With thermal motor protection without temperature sensors, different thermal motor models are used for calculation. The temperatures according to the motor temperature model are calculated from the motor operating data. Whereby, the masses of the motor parts and the type of ventilation, for the I²t model (for synchronous motors), the motor current in relation to the operating time is taken into consideration in the calculation. For motor temperature protection without temperature sensor, p0600[0...n] is set to 0, p0612.00 to 1 and p0612.01 to 1.

If you are using motors from the motor lists, or with integrated DRIVE-CLiQ connection, the relevant motor data is automatically transferred to the Control Unit.

In the control type "Vector Control", using p0610 the reaction of the drive to a detected motor overtemperature can be parameterized. The motor may either be switched off immediately – or continue to operate at reduced power, reduced load, under adapted conditions.

9.5.1 Thermal motor models

Motor temperature measurements using temperature sensors protect the motor against overheating. If temperature sensors are not being used, then instead, the thermal motor model can be used as motor protection. Thermal motor models respond more dynamically than temperature sensors, and therefore provide better protection relating to brief overload conditions.

Depending on the particular temperature model, the temperature rise is either assigned to various motor parts (stator, rotor) or is calculated from the motor current and the thermal time constant. A combination of thermal motor model with additional temperature sensors can also be used.

NOTICE

Damage to the motor when operated without temperature sensors

The thermal model cannot protect the motor in the event of incorrect installation, elevated ambient temperature, or incorrect parameter assignment, and as a consequence, the motor can be damaged.

- Comply with the motor installation regulations.
- Commission the motor as specified.

9.5.1.1 Thermal motor model 1

Thermal motor model 1 is only used for selected synchronous motors, and protects against brief overload conditions. It is based on a continuous current measurement. The dynamic load of the motor is determined from the motor current and the motor model time constant. The actual value of the motor winding temperature can be measured using a temperature sensor and subsequently taken into account.

The model motor temperature is indicated in r0632. It is calculated from the following values:

- Absolute current actual value r0068
- I2t motor model thermal time constant p0611
- Motor stall current p0318
- Measured motor temperature r0035 (if available)
- Motor temperature at rated load p0605 (for expansion p0627)

Commissioning the motor model

You activate the thermal I2t motor model with p0612.00 = 1. The expansion makes it more transparent when setting the motor model. You can additionally activate this expansion using p0612.08 = 1.

Note

When commissioning the motor, thermal motor model 1 (p0612.00 = 1) including expansion (p0612.08 = 1) is automatically activated.

Preconditions for automatic activation:

- Rotating permanent-magnet synchronous motors are used
 - There is no motor sensor
 - No (other) thermal motor model is activated
-

Important settings

The most important parameters for thermal motor model 1 and/or for the expansion of this model are subsequently explained.

When the expansion is subsequently activated, the corresponding parameters of the expansion are preassigned with the parameter values before activating the expansion.

Parameters for the following settings:		Explanation
p0612.08 = 0	p0612.08 = 1	
p0605	p5390	Alarm threshold If the model motor temperature (r0632) exceeds the alarm threshold, alarm A07012 "Drive: Motor temperature model 1/3 over-temperature" is output
p0615	p5391	Fault threshold If the model motor temperature (r0632) exceeds the fault threshold, fault F07011 "Drive: Motor overtemperature" is output.
p0605	p0627 + 40°C	Rated temperature (winding) Defines the rated overtemperature of the stator winding referred to the ambient temperature.
1.333 (fixed value)	p5350	Boost factor Defines the boost factor for the copper losses at standstill.
p0612 = 0x1	p0612 = 0x101	Activation Activates the motor module and/or additionally the expansion.
r0632	r0632	Actual temperature Indicates the stator winding temperature of the motor temperature model.
r0034	r0034	Motor utilization Indicates the actual motor utilization level.

Taking into account the ambient temperature

If, for thermal motor model 1, a temperature sensor has not been parameterized, then motor module 1 automatically uses an ambient temperature of 20°C for the calculation. You can enter one of these ambient temperatures deviating from the standard temperature as follows:

1. Activate the setting p0612.12 = 1.
This enables parameter p0613. The factory setting is 20° C.
2. If you wish to take into account an ambient temperature, which deviates from the factory setting, in the motor model, then enter the expected ambient temperature in p0613.

Note

When commissioning the motor, the setting p0612.12 = 1 is automatically activated. p0613 can be parameterized when required.

9.5.1.2 Thermal motor model 2

Thermal motor model 2 is used for induction motors.

Enter the total motor mass in p0344.

- p0625 = ambient temperature
- p0626 = overtemperature, stator iron
- p0627 = overtemperature, stator winding
- p0628 = rotor winding temperature rise

The motor temperatures are calculated on the basis of motor measured values. The calculated temperatures are indicated in the parameters:

- r0630 Motor temperature model ambient temperature
- r0631 Motor temperature model stator iron temperature
- r0632 Motor temperature model stator winding temperature
- r0633 Motor temperature model rotor temperature

When operated with an additional KTY84 or PT1000 temperature sensor, the calculated temperature value from thermal motor model 2 is continuously corrected to track the measured temperature value. After deactivating the temperature sensor with p0600 = 0, the calculation continues with the last measured temperature value.

Commissioning the motor model

You activate the thermal motor model 2 with p0612.01 = 1. The expansion makes the motor model more precise. You can additionally activate this expansion using p0612.09 = 1.

Note

When commissioning the motor, the expansion of thermal motor model 2 (p0612.09 = 1) is automatically activated.

9.5.1.3 Thermal motor model 3

Thermal motor model 3 is only intended for certain Siemens motors, which do not have their own integrated temperature sensors. Thermal motor model 3 is a thermal 3-mass model. It is activated with $p0612.02 = 1$. The necessary parameters are automatically transferred when commissioning via DRIVE-CLiQ.

Note

When commissioning, thermal motor model 3 is automatically set after selecting the intended Siemens motor (p0301). The parameters are set to values appropriate for the particular motor type.

The motor temperatures are calculated based on the motor measured values. The calculated temperatures are indicated in the parameters:

- r0034 thermal motor load
- p0613 motor temperature model ambient temperature
- r0631 Motor temperature model stator iron temperature
- r0632 Motor temperature model stator winding temperature
- r0633 Motor temperature model rotor temperature

Table 9- 2 Important settings

Parameter:	Explanation:
p5390	Alarm threshold If the model motor temperature (r0632) exceeds the alarm threshold, alarm A07012 "Drive: Motor temperature model 1/3 overtemperature" is output
p5391	Fault threshold If the model motor temperature (r0632) exceeds the fault threshold, fault F07011 "Drive: Motor overtemperature" is output.
p5350	Boost factor Defines the boost factor for the copper losses at standstill.

9.5.1.4 Function diagrams and parameters

Alarms (see SINAMICS S120/S150 List Manual)

- F07011 Drive: Motor overtemperature
- A07012 Drive: Motor temperature model 1/3 overtemperature

Function diagrams (see SINAMICS S120/S150 List Manual)

- 8016 Signals and monitoring functions - thermal monitoring motor, Mot_temp ZSW F/A
- 8017 Signals and monitoring functions - motor temperature model - 1 (I2t)
- 8018 Signals and monitoring functions - motor temperature model 2
- 8019 Signals and monitoring functions - motor temperature model 3

Overview of important parameters (see SINAMICS S120/S150 List Manual)

Thermal motor model 1

- r0034 CO: Thermal motor load
- p0318[0...n] Motor stall current
- p0605[0...n] Mot_temp_mod 1/2 threshold and temperature value
- p0611[0...n] I2t motor model thermal time constant
- p0612[0...n] Mot_temp_mod activation
- p0613[0...n] Mot_temp_mod 1/3 ambient temperature
- p0615[0...n] Mot_temp_mod 1 (I2t) fault threshold
- p0627[0...n] Motor overtemperature, stator winding
- p0632[0...n] Mot_temp_mod stator winding temperature
- p5350[0...n] Mot_temp_mod 1/3 zero speed boost factor
- p5390[0...n] Mot_temp_mod 1/3 alarm threshold
- p5391[0...n] Mot_temp_mod 1/3 fault threshold

Thermal motor model 2

- p0344[0...n] Motor weight (for thermal motor type)
- p0612[0...n] Mot_temp_mod activation
- p0617[0...n] Stator thermally relevant iron component
- p0618[0...n] Stator thermally relevant copper component
- p0619[0...n] Rotor thermally relevant mass
- p0625[0...n] Motor ambient temperature during commissioning
- p0626[0...n] Motor overtemperature, stator iron
- p0627[0...n] Motor overtemperature, stator winding
- p0628[0...n] Motor overtemperature rotor
- r0630[0...n] Mot_temp_mod ambient temperature
- r0631[0...n] Mot_temp_mod stator iron temperature
- r0632[0...n] Mot_temp_mod stator winding temperature
- r0633[0...n] Mot_temp_mod rotor temperature

Thermal motor model 3

- p0612[0...n] Mot_temp_mod activation
- p0613[0...n] Mot_temp_mod 1/3 ambient temperature
- r0631[0...n] Mot_temp_mod stator iron temperature
- r0632[0...n] Mot_temp_mod stator winding temperature
- r0633[0...n] Mot_temp_mod rotor temperature
- p5350[0...n] Mot_temp_mod 1/3 zero speed boost factor
- p5390[0...n] Mot_temp_mod 1/3 alarm threshold
- p5391[0...n] Mot_temp_mod 1/3 fault threshold

9.5.2 Motor temperature sensing

Temperature sensors

The motor temperature is sensed using temperature sensors integrated in the motor windings. The sensors used are selected as standard from the following four different sensor types:

- PTC
- KTY84
- PT100/PT1000
- Bimetallic sensor with NC contact (abbreviated, "bimetal NC contact")

Function of the PTC

The temperature sensor is connected to the Sensor Module at the appropriate terminals (-Temp) and (+Temp) (see the relevant section in the SINAMICS S120 Control Units and Supplementary System Components Manual). The threshold value for switching over to an alarm or fault is 1650 Ω .

A PTC usually has a strongly non-linear characteristic, and as a consequence is used just like a switch. When the typical rated response temperature is exceeded, then the resistance changes abruptly (step function). The tripping resistance is $\geq 1650 \text{ Ohm}$.

- p0600 = 1 activates the motor temperature sensing using sensor 1
- p0601 = 1 sets temperature sensor type "PTC"

Function of the KTY

The temperature sensor is connected to the Sensor Module at the appropriate terminals (-Temp) and (+Temp) (see the relevant section in the SINAMICS S120 Control Units and Supplementary System Components Manual). A KTY84/1C130 temperature sensor has an almost linear characteristic and is therefore also suitable for continuously measuring and displaying the motor temperature.

You can find more detailed information on measurable temperature actual values or on adjustable temperature values for fault and alarm thresholds in the SINAMICS S120 Commissioning Manual STARTER, Chapter "Temperature sensors for SINAMICS components".

- p0600 = 1 activates the motor temperature sensing using sensor 1
- p0601 = 2 sets temperature sensor type "KTY"

Function of the PT100/PT1000

A PT100 or PT1000 is in principle a PTC with a very linear characteristic, and is suitable for continuous and exact temperature measurements. Not every sensor input is PT100/PT1000-capable.

9.5 Thermal motor protection

You can find more detailed information on measurable temperature actual values or on adjustable temperature values for fault and alarm thresholds in the SINAMICS S120 Commissioning Manual STARTER, Chapter "Temperature sensors for SINAMICS components".

- p0600 = 1 activates the motor temperature sensing using sensor 1
- p0601 = 5 sets temperature sensor type "PT100"
or
- p0601 = 6 sets temperature sensor type "PT1000"

Function of the bimetallic NC contact

A bimetallic NC contact at a certain nominal response temperature actuates a switch. The tripping resistance is <100 Ohm. Not every sensor input is bimetal NC contact-capable.

- p0600 = 1 activates the motor temperature sensing using sensor 1
- p0601 = 4 sets temperature sensor type "Bimetallic NC contact"

Temperature sensor type for multiple temperature channels

Set p0601 = 10 if you wish to use several temperature channels. The sensors are then interconnected via BICO

9.5.3 Sensor Modules

Sensor Modules are needed when additional temperature sensors are to be connected via DRIVE-CLiQ. Various Sensor Modules are available to do this:

- Sensor Module Cabinet-Mounted (SMC) for rail mounting in control cabinets
 - Sensor Module External (SME) in degree of protection IP67, installed close to the motor
- PTC, KTY84, PT1000 temperature sensors - and in some cases - bimetallic NC contacts, can be connected to the Sensor Modules.

Table 9- 3 Temperature sensor connection

Device	Interface	+Temp	-Temp	Temperature sensor type
SMC10	X520	13	25	KTY84/PTC/PT1000
SMC20	X520	13	25	KTY84/PTC/PT1000
SMC30	X520	1	8	KTY84/PTC/PT1000
	X531	4	3	KTY84/PTC/PT1000
SMC40	-	-		A temperature sensor cannot be connected
SME20	X100	9	7	KTY84/PTC/PT1000
SME25	-	-		A temperature sensor cannot be connected
SME120	X200	See below		KTY84/PTC/PT1000/bimetallic NC contact
SME125	X200	See below		KTY84/PTC/PT1000/bimetallic NC contact

9.5.3.1 Sensor Module Cabinet-Mounted

A Sensor Module Cabinet-Mounted (SMCx0) evaluates the sensor signals. The results are transferred to the drive for further processing via DRIVE-CLiQ. The SMCx0 is intended for operation in a control cabinet. SMC10, SMC20, SMC30 and SMC40 differ regarding the encoder interfaces. They have the same function for detecting the motor temperature. Alternatively, an SMC30 offers two encoder connections. The encoder can either be connected at interface X520, a 15 pin Sub-D connector – or at interface X521/X531, via terminal strip.

A SMC40 only supports pure digital encoders without incremental signals. These are only encoders with the order designation EnDat 22. In contrast to the other Sensor Modules, the SMC40 is a double SMC. Wiring is via two DRIVE-CLiQ cables. Motor temperature monitoring is not possible with the SMC40.

Note

The SMC40 can only be fully configured when an associated EnDat 2.2 encoder is connected. Without a connected encoder, it is not possible to integrate the SMC40 into the topology.

Note**No safety functions with SMC40**

No safety functions are supported with firmware V4.5.

9.5.3.2 Sensor Module External

A Sensor Module External (SME) is required if the sensor interface is to be installed close to the motor sensor outside a control cabinet. The SME has an IP67 degree of protection.

9.5.3.3 Sensor Module SME 20/25

The SME20 and SME25 evaluate encoder and sensor data. The calculated values are transferred to the Control Unit via DRIVE-CLiQ. SME20 and SME25 differ regarding the encoder interface.

A temperature sensor cannot be connected to the SME25 to sense the motor temperature. Instead, use an SME125.

9.5.3.4 Sensor Module External 120/125

A Sensor Module External 120 (SME120) or Sensor Module External 125 (SME125) is required for the following application conditions:

- The sensor interface is installed close to the motor outside a control cabinet
- Several motor temperature channels are required
- The motor temperature sensors do not have safe protective separation
- Safe protective separation is not possible.

SME12x has an IP67 degree of protection. SME12x are particularly suitable for linear and torque motor applications.

If $r0458[0...2].8 = 1$, up to three temperature sensors can be connected at terminal block X200. Each sensor is assigned to a temperature channel.

The SME12x evaluates the data of the temperature sensors and makes the calculated values available via DRIVE-CLiQ for further processing.

Table 9- 4 Assignment of terminal strip X200 for the temperature sensors

Terminal	Function	Chan- nel	Parameter	Temperature sensor type
1	-Temp	2	p4601[0]	KTY84/PTC/PT1000/bimetallic NC contact Linear and torque motors: KTY84/PT1000
2	+Temp			
3	+Temp	3	p4602[0]	KTY84/PTC/PT1000/bimetallic NC contact Linear and torque motors: PTC – triplet 1 or bimetal NC contact
4	-Temp			
5	+Temp	4	p4603[0]	KTY84/PTC/PT1000/bimetallic NC contact Linear and torque motors: PTC – triplet 1 or bimetal NC contact
6	-Temp			

Temperature measurement

- $p0600 = 1/2/3$ selects the additional motor temperature measurement via channels 2 to 4.
- $p0601 = 10$ activates the evaluation via several temperature channels SME12x.

KTY84

- $p4601[0...n]$ to $p4603[0...n] = 20$ sets temperature sensor type KTY.
- If the value in parameter $r4620[0...3]$ is not equal -200 °C , then the temperature display is valid. The actual value of the temperature sensors is displayed:
 - $r4620[1]$ temperature sensors from channel 2
 - $r4620[2]$ temperature sensors from channel 3
 - $r4620[3]$ temperature sensors from channel 4

PT1000

- p4601[0...n] to p4603[0...n] = 60 sets temperature sensor type PT1000.
- If the value in parameter r4620[0...3] is not equal -200 °C, then the temperature display is valid. The actual value of the temperature sensors is displayed:
 - r4620[1] temperature sensors from channel 2
 - r4620[2] temperature sensors from channel 3
 - r4620[3] temperature sensors from channel 4

PTC

- p4601[0...n] to p4603[0...n] = 10/11/12 sets the temperature sensor type PTC, the evaluation type and activates the evaluation.
 - p4601[0...n] = 10 PTC fault
 - p4601[0...n] = 11 PTC alarm
 - p4601[0...n] = 12 PTC alarm and timer
- r4620[0...3] = -200 °C.

Bimetallic NC contact

- p4601[0...n] to p4603[0...n] = 30/31/32 sets the temperature sensor type bimetal NC contact, the evaluation type and activates the evaluation.
 - p4601[0...n] = 30 bimetal NC contact fault
 - p4601[0...n] = 31 bimetal NC contact alarm
 - p4601[0...n] = 32 bimetal NC contact alarm and timer
- r4620[0...3] = -200 °C.

9.5.4 Terminal Modules

Terminal Modules provided the drive system with additional analog and digital data inputs and outputs. They are intended for use in control cabinets. The Terminal Modules are connected via DRIVE-CLiQ with the drive system. Terminal Modules TM31, TM120 and TM150 provide inputs for temperature sensors.

- The TM31 can evaluate one temperature sensor.
- The TM120 can evaluate up to 4 temperature sensors. The sensor inputs are electrically isolated.
- The TM150 can evaluate up to 12 sensors. The sensors can be split up into a maximum of 3 groups. Each sensor can be freely assigned to one of the group.

Table 9- 5 Temperature sensor connection

Device	Interface	Chan- nel	+Tem p	-Temp	Temperature sensor type
TM31	X522	0	7	8	KTY84/PTC/PT1000
TM120	X521	0	2	1	KTY84-1C130/PTC/PT1000/bimetallic NC contact, Linear motor: KTY84-1C130/PT1000
		1	4	3	KTY84-1C130/PTC/PT1000/bimetallic NC contact, Linear motor: KTY84-1C130/PT1000
		2	6	5	KTY84-1C130/PTC/PT1000/bimetallic NC contact, Linear motor: KTY84-1C130/PT1000
		3	8	7	KTY84-1C130/PTC/PT1000/bimetallic NC contact, Linear motor: KTY84-1C130/PT1000
TM150	X531 ¹⁾	0	1 3	2 4	KTY84-1C130/PTC/bimetallic NC contact/PT100/PT1000
	X532 ¹⁾	1	1 3	2 4	KTY84-1C130/PTC/bimetallic NC contact/PT100/PT1000
	X533 ¹⁾	2	1 3	2 4	KTY84-1C130/PTC/bimetallic NC contact/PT100/PT1000
	X534 ¹⁾	3	1 3	2 4	KTY84-1C130/PTC/bimetallic NC contact/PT100/PT1000
	X535 ¹⁾	4	1 3	2 4	KTY84-1C130/PTC/bimetallic NC contact/PT100/PT1000
	X536 ¹⁾	5	1 3	2 4	KTY84-1C130/PTC/bimetallic NC contact/PT100/PT1000

¹⁾ You will find more detailed information on sensor connections in the section on "Terminal Module 150".

9.5.5 Terminal Module 31

A Terminal Module 31 (TM31) is used when additional digital and analog inputs/outputs required. The temperature sensor is connected at terminal X522. The values of the fault and/or alarm thresholds can be set in parameter p4102[0..1] from -48 °C to 251 °C. p4102 = 251°C deactivates the alarm and fault threshold. The factory setting is 100 °C for the alarm threshold and 120 °C for the fault threshold.

Temperature measurement

- p0600 = 10 activates the motor temperature measurement via the external sensor.
- p0603 sets the signal source for the evaluation of the motor temperature
- p4100 = 0 disables the evaluation. Then parameter r4105 = -300°C.

PTC

- p4100 = 1 sets the PTC temperature sensor type and activates the evaluation.
- r4105 indicates the following values:
 - If the temperature actual value is less than the nominal response temperature, then -50°C is displayed.
 - If the temperature actual value is higher than the nominal response temperature, then 250 °C is displayed.
 - If the actual temperature value is invalid (F35920 initiated), then -300°C is displayed.
 - If p4100 = 0, -300°C is displayed.

KTY84

- p4100 = 2 sets the KTY84 temperature sensor type and activates the evaluation.
- r4105 indicates the following values:
 - The actual temperature value of the temperature evaluation
 - -300 °C if no sensor has been selected or the temperature actual value is invalid

PT1000

- p4100 = 6 sets temperature sensor type PT1000 and activates the evaluation.
- r4105 indicates the following values:
 - The actual temperature value of the temperature evaluation
 - -300 °C if no sensor has been selected or the temperature actual value is invalid

9.5.6 Terminal Module 120

If the temperature sensors in the installed motors do not have protective separation, then you require a Terminal Module 120 (TM120). Up to four different temperature sensors can be connected to the TM120. The TM120 senses the actual temperature values and evaluates them. The fault and alarm thresholds (p4102) of the actual temperature values can be set from -48°C up to 251°C . Temperature sensors are connected at the TM120 at terminal strip X521 according to the table above.

Note

Fault messages

Fault messages for an individual temperature channel in the TM120 are propagated to all other drive objects connected with the TM120.

As such all other drive objects (connected with the TM120) also trigger a fault.

You will find additional information in the SINAMICS S120 Control Units and Supplementary System Components Manual.

Temperature measurement

- p0600[0...n] = 20 or 21 activates the motor temperature sensing via an external sensor.
- p0601[0...n] = 11 sets the evaluation for several temperature channels.
- p0608[0...3] allocates the temperature channels for the motor temperatures to signal source 2.
- p0609[0...3] allocates the temperature channels for the motor temperatures to signal source 3.
- p4100[0...n] = 0 deactivates temperature evaluation.
- r4101[0...3] indicates the actual resistance value of the respective temperature sensor. The maximum measurable resistance is $2170\ \Omega$.
- p4102[0/2/4/6] sets the alarm thresholds of the temperature sensors to between -48°C and 250°C .
- p4102[1/3/5/7] sets the fault thresholds of the temperature sensors to between -48°C and 250°C .
- p4102[0...7] = 251°C deactivates the alarm and/or fault message that has been set.
- p4610[0...n] to p4613[0...n], assigns up to four temperature sensors to the motor and defines the responses.

- r4620[0...3] \neq -200° C means:
 - a KTY84/PT1000 is connected
 - the temperature display is valid.
- r4620[0...3] = -200° C means:
 - a PTC or a bimetal NC contact is connected
 - there is a temperature sensor fault
 - the sensor channel is deactivated
 - the temperature evaluation is deactivated

KTY84

- p4100[0...3] = 2 assigns the temperature sensor type KTY84 to a corresponding channel 1 to 4, and activates the evaluation.
- r4105[0...3] displays the actual temperature value of the measuring channel involved of the temperature evaluation. If no sensor has been selected or if the actual temperature value is invalid, the value -300° C is in the parameter.

PT1000

- p4100[0...3] = 6 assigns the temperature sensor type PT1000 to a corresponding channel 1 to 4, and activates the evaluation.
- r4105[0...3] displays the actual temperature value of the measuring channel involved of the temperature evaluation. If no sensor has been selected or if the actual temperature value is invalid, the value -300° C is in the parameter.

PTC

- p4100[0...3] = 1 sets temperature sensor type PTC to the corresponding channel 1 to 4, and activates the evaluation.
- r4105[0...3] displays the actual temperature value of the temperature evaluation.
 - If the actual temperature value is lower than the rated response temperature, then r4105[0...3] is set to -50° C.
 - If the actual temperature value is higher than the rated response temperature, then r4105[0...3] is set to 250° C.
 - If no sensor has been selected or if the actual temperature value is invalid, then r4105[0...3] is set to -300° C.

Bimetallic NC contact

- p4100[0...3] = 4 sets the temperature sensor type bimetal NC contact, and activates the evaluation.
- r4105[0...3] displays the actual temperature value of the temperature evaluation.
 - If the actual temperature value is lower than the rated response temperature, then r4105[0...3] is set to -50° C.
 - If the actual temperature value is higher than the rated response temperature, then r4105[0...3] is set to 250° C.
 - If no sensor has been selected or if the actual temperature value is invalid, then r4105[0...3] is set to -300° C.

9.5.7 Terminal Module 150

The Terminal Module 150 (TM150) has 6x 4-pole terminals for temperature sensors. Temperature sensors can be connected in a 1x2, 1x3 or 1x4-wire system. In a 2x2-wire system, up to 12 input channels can be evaluated. 12 input channels can be evaluated in the factory setting. The temperature channels of a TM150 can be subdivided into three groups and evaluated together.

The TM150 can acquire the signals from KTY84, PTC, bimetallic NC contact, PT100 and PT1000 temperature sensors and evaluate them. The fault and/or alarm thresholds of the temperature values can be set from -99° C up to 251° C. The temperature sensors are connected at terminal strip X531 to X536 according to the following table.

The TM150 temperature inputs are not isolated.

Note

Fault messages

Fault messages for an individual temperature channel in the TM150 are propagated to all other drive objects connected with the TM150.

As such all other drive objects (connected with the TM150) also trigger a fault.

You can find additional information in the function diagrams 9625, 9626 and 9627 in the SINAMICS S120/S150 List Manual.

Selecting the sensor types

- p4100[0...11] sets the sensor type for the respective temperature channel.
- r4105[0...11] indicates the actual value of the temperature channel.
 - For switching temperature sensors, such as PTC and bimetallic NC contact, two limit values are displayed symbolically:
 - r4105[0...11] = -50° C: The actual temperature value is below the rated response temperature.
 - r4105[0...11] = +250° C: The actual temperature value is above the rated response temperature.

Note

For PTC and bimetallic NC contact the following applies:

What is shown in r4105[0...11] does not correspond to the actual temperature value.

Table 9- 6 Selecting the sensor types

Value of p4100[0...11]	Temperature sensor	Temperature display range r4105[0...11]
0	Evaluation disabled	-
1	PTC thermistor	-50° C or +250° C
2	KTY84	-99° C to +250° C
4	Bimetallic NC contact	-50° C or +250° C
5	PT100	-99° C to +250° C
6	PT1000	-99° C to +250° C

Measuring the cable resistances

When using 2-wire sensors, to increase the measuring accuracy, the cable resistance can be measured and saved. To do this, short-circuit the sensor cable as close as possible to the sensor. The procedure is described in the SINAMICS S120/150 List Manual under p4109[0...11]. The measured cable resistance is then taken into account when evaluating the temperature. The cable resistance value is saved in p4110[0...11].

Line filter

A line filter is activated to suppress noise radiated from the line supply. Using p4121, the filter can be set to a 50 Hz or 60 Hz line frequency.

9.5.7.1 Measurement with up to 6 channels

Temperature measurement with a 2-wire sensor

With $p4108[0...5] = 0$, you evaluate a sensor in a 2-wire system at a 4-wire connection at terminals 1 and 2. Terminals 3 and 4 remain open.

Temperature measurement with a 3-wire sensor

With $p4108[0...5] = 2$, you evaluate a sensor in a 3-wire system at a 4-wire connection at terminals 3 and 4. The measuring cable is connected at terminal 1. You must short-circuit terminals 2 and 4.

Temperature measurement with a 4-wire sensor

With $p4108[0...5] = 3$, you evaluate a sensor in a 4-wire system at a 4-wire connection at terminals 3 and 4. The measuring cable is connected at terminals 1 and 2.

You can find additional information in function diagram 9626 in the SINAMICS S120/S150 List Manual.

9.5.7.2 Measurement with up to 12 channels

Temperature measurement with two 2-wire sensors

With $p4108[0...5] = 1$ you can acquire the signals from two sensors in 2-wire technology. The first sensor is connected to terminals 1 and 2. The 2nd sensor (number = first sensor + 6) is connected at terminals 3 and 4. You can find additional information in function diagram 9627 in the SINAMICS S120/S150 List Manual.

When connecting 2 2 wire sensors to terminal X531, the 1st sensor is assigned to temperature channel 1. The 2nd sensor is assigned to channel 7 (1+6).

Up to 12 temperature sensors can be connected to a TM150.

Note

Connection diagram for 12 temperature channels

The temperature sensors connected to a TM150 are not numbered consecutively. The first 6 temperature channels retain their numbering of 0 to 5. The other 6 temperature channels are consecutively numbered from 6 to 11, starting at terminal X531 (see function diagram 9627 in the SINAMICS S120/S150 Lists Manual).

Example of 8 temperature channels:

2x2 conductors at terminal X531: $p4108[0] = 1$ \triangleq sensor 1 is at channel 0 and sensor 2 is at channel 6

2x2 wires at terminal X532: $p4108[1] = 1$ \triangleq sensor 1 is at channel 1 and sensor 2 is at channel 7

1x3 wires at terminal X533: $p4108[2] = 2$ \triangleq sensor 1 is at channel 2

1x3 conductor is at terminal X534: $p4108[3] = 2$ \triangleq sensor 1 is at channel 3

1x4 conductor is at terminal X535: $p4108[4] = 3$ \triangleq sensor 1 is at channel 4

1x2 conductor is at terminal X536: $p4108[5] = 0$ \triangleq sensor 1 is at channel 5

9.5.7.3 Forming groups of temperature sensors

You can combine the temperature channels to form groups using parameter p4111[0...2]. For each group, the following calculated values are provided from the temperature actual values (r4105[0...11]):

- Maximum: r4112[0...2], (index 0,1,2 = group 0,1,2)
- Minimum: r4113[0...2]
- Average value: r4114[0...2]

Example:

The temperature actual value from channels 0, 3, 7, and 9 should be combined in group 1:

- p4111[1].0 = 1
- p4111[1].3 = 1
- p4111[1].7 = 1
- p4111[1].9 = 1

The calculated values from group 1 are available in the following parameters for interconnection:

- r4112[1] = maximum
- r4113[1] = minimum
- r4114[1] = average value

Note

Forming groups of temperature channels

Only form groups of continuously measuring temperature sensors. The switching temperature sensors PTC and bimetallic NC contacts are only assigned two temperatures - 50° C and +250° C, depending on the state. Within a group with continuous temperature actual values, the calculation of the maximum/minimum/average value temperature is significantly falsified by taking into account switching temperature sensors.

9.5.7.4 Evaluating temperature channels

For each of the individual 12 temperature channels, an alarm threshold and a fault threshold can be set in p4102[0...23]. The even parameter indices contain the alarm threshold and the uneven parameter indices, the fault threshold. The temperature thresholds can be set between -99°C and +251°C for each channel.

If the evaluation of the temperature actual value from p4105[0...11] exceeds the alarm threshold set in p4102[0...23], then an alarm is output at r4104.0...23. Timer p4103[0...11] is started at the same time.

If, after the timer has expired, the temperature actual value is still above the alarm threshold, then an appropriate fault is output. This fault can be acknowledged as soon as the temperature actual value is again below the alarm threshold.

If the evaluation of the temperature actual value from p4105[0...11] has exceeded the fault threshold set in p4102[0...23], then the corresponding fault is immediately activated.

Using p4118[0...11], a hysteresis for p4102[0...23] can be set for each channel.

Using p4119[0...11], a filter can be activated to smooth the temperature signal for each channel.

The time constant of the filter depends on the number of active temperature channels and can be read in r4120.

Failure of a sensor

Using parameter p4117[0...2], the response to the failure of a temperature sensor can be set within a group:

- p4117 = 0 is set. The failed sensor is not taken into account.
- p4117 = 1 is set. The group outputs the value -300 °C to the outputs for the maximum value, minimum value and the mean value.

9.5.7.5 Setting the smoothing time for temperature channels

For long or unshielded temperature cables, interference can cause the TM150 to respond and incorrectly shutdown the drive. To avoid this, a smoothing time can be set for every temperature channel in TM150 for the respective temperature signal.

Setting the smoothing time

The smoothing is realized using a lowpass filter, 1st order. The effective smoothing time constant depends on the number of simultaneously active temperature channels, and is indicated in parameter r4120 [0...11].

The smoothing time constant to be set is calculated using the following formula:

$$\text{Smoothing time constant (p4122)} \geq 2 \times \text{active number of channels} \times 50 \text{ ms}$$

Procedure:

1. Open the inputs/outputs of the TM150 component in the STARTER commissioning tool ("Drive unit xy > Input/output component > TM150_component > Inputs/outputs").
2. Select the desired temperature sensor (e.g. sensor 5) using the tab.
3. Click on the "Smoothing" button in the circuit diagram of the displayed temperature sensor/channel (for sensor 5: p4119[5] = 1).

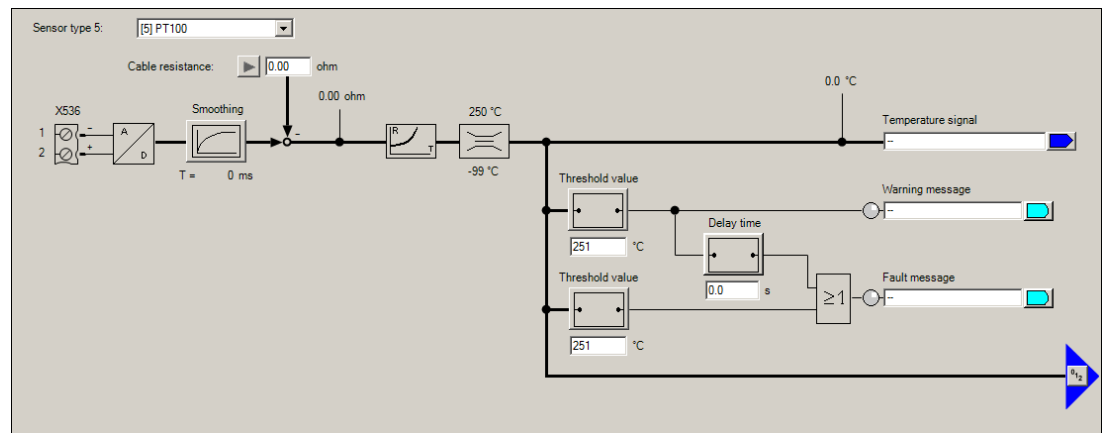

Figure 9-3 Smoothing time of a temperature sensor/channel.

Thus the filter to smooth the temperature signal is activated. Under the "Smoothing" button, an entry field for the necessary smoothing time constant (p4122[0...11]) is displayed.

4. Enter the required smoothing time constant (p4122) into the entry field.

The smoothing time constants can be calculated using the aforementioned formula. To do this, you have to know over how many temperature channels you wish to configure a smoothing time.

The implemented smoothing time is displayed after the entry in p4122 beneath the entry field for the selected temperature channel (r4120[0...11]).

5. Repeat steps 2 to 4 for all temperature sensors/channels used.

9.5.8 Motor Module/Power Module chassis format

Motor Modules have a direct connection for a motor temperature sensor. You can evaluate PTC, KTY84, PT100, PT1000 temperature sensors or bimetallic NC contacts. The terminals of the temperature sensors at a Motor Module depend on their design.

Table 9- 7 Temperature sensor connection at the Motor Module

Device	Terminal	+Temp	-Temp
Single Motor Module chassis	X41	4	3
Single Motor Module booksize	X21	1	2
Single Motor Module booksize compact	X21	1	2
Double Motor Module booksize	X21 / X22	1 / 1	2 / 2

Activation of the temperature sensing

With p0600[0...n] = 11, motor temperature sensing via a Motor Module is activated.

Setting the temperature sensor

The temperature sensor type is set using p0601[0...n]. When connecting a temperature sensor to terminal X41 of a chassis unit, you must specify to which power unit the temperature sensor is to be connected when power units are connected in parallel. The desired power unit is connected via p0602.

Note

Bimetallic NC contact is only possible for booksize formats

Temperature sensing using a bimetallic NC contact is only possible with Motor Modules in the booksize format.

Note

PT100 is only possible for the chassis format

Temperature sensing using a PT100 is only possible with Motor Modules in the chassis format.

If r0192.15 = 1 is displayed, then the PT 100 temperature sensor type can be selected with p0601[0...n] = 5.

A motor temperature offset can be set using p0624 [0...n].

Power Module chassis

A Power Module in the chassis format has one temperature channel and can evaluate PTC, KTY84, PT1000 and PT100 temperature sensors (r0192.15 = 1).

Table 9- 8 Temperature sensor connection at a Power Module

Device	Terminal	+Temp	-Temp
Power Module chassis	X41	4	3

9.5.9 Connection of the CU310-2 and the CUA31/CUA32 adapters

The Control Unit Adapter CUA31 and CUA32 have one temperature channel. The terminal strip in the CUA31 has an interface for a motor temperature sensor. The temperature sensor can be alternatively connected at the CUA32 via the encoder interface.

The Control Unit CU310-2 DP/PN has two independent temperature channels. The motor temperature sensors can be connected via two interfaces. One of the channels is in the encoder interface, the second channel is on the terminal strip. PTC or KTY84 temperature sensors can be connected and evaluated.

Table 9- 9 Temperature sensor connection

Device		Interface	+Temp	-Temp	PTC	KTY	PT100
CU 310-2 DP/PN	Encoder interface	X120	1	2	Yes	Yes	--
	Terminal strip	X23	1	8	Yes	Yes	--
CUA31	Terminal strip	X210	1	2	Yes	Yes	--
CUA32	Terminal strip	X210	1	2	Yes	Yes	--
	Encoder interface	X220	1	8	Yes	Yes	--

CUA31

Setting the temperature measurement and the temperature channels:

- p0600[0...n] = 11 sets the temperature channel via CU terminals.
- p0601[0...n] = 0/1/2/3/5 sets the temperature sensor type and the response.

CUA32

Setting the temperature measurement and the temperature channels:

- p0600[0...n] = 10 sets the temperature sensing via BICO interconnection.
- p4600[0...n] sets the sensor type for temperature channel 1 (encoder interface).
- p4601[0...n] sets the sensor type for temperature channel 2 (terminal strip).

CU310-2 DP/PN (AC Drive)

Setting the temperature sensing and the temperature channels:

- p0600[0...n] = 10 sets the temperature sensing via BICO interconnection.
- p4600[0...n] sets the sensor type for temperature channel 1 (encoder interface).
- p4601[0...n] sets the sensor type for temperature channel 2 (terminal strip).

9.5.10 Motor with DRIVE-CLiQ

The motor and encoder data are saved as an electronic type plate in a motor equipped with a DRIVE-CLiQ connection. This data is transferred to the Control Unit when commissioning. As a consequence, when commissioning this motor type, all of the necessary parameters are pre-assigned and set automatically. The same is true for the parameters required to monitor the motor temperature. Other changes are not required.

The default settings for monitoring the motor temperature are:

- p0600 = 1, motor temperature sensor for monitoring via encoder 1
- p0601 = 2, the motor temperature sensor type is a KTY84.
- p0604[0...n] motor temperature alarm threshold
- p0605[0...n] motor temperature fault threshold
- p0606[0...n] motor temperature timer (timer to changeover from an alarm to a fault value).

9.5.11 Temperature sensor evaluation

Temperature sensing using PT1000 or KTY84

- When the alarm threshold p0604 is exceeded, alarm A07910 is output. For vector control, using parameter p0610, you can set the drive response when the alarm is initiated:
 - 0: No response, alarm only A07910, no reduction of I_{max}
 - 1: Alarm A07910 and fault F07011, reduction of I_{max}
 - 2: Alarm A07910 and fault F07011, no reduction of I_{max}
 - 12: Alarm (A07910) and fault (F07011), no reduction of I_{max}, temperature saved
- When the fault threshold is reached (set via p0605, factory setting = 145 °C), fault F07011 is triggered in conjunction with the setting in p0610.

Temperature measurement via PTC

- Alarm A07910 is triggered once the PTC responds
- Fault F07011 is triggered once the waiting time defined in p0606 has elapsed

Sensor monitoring for wire breakage/short-circuit

- A sensor monitoring function for a short-circuit in the sensor cable is possible for a PTC and a PT1000 or KTY84 sensor. Wire breakage monitoring is possible for a PT1000 or KTY84 sensor:
If the temperature value lies outside the specified range of -140 °C ... +250 °C, then it is probable that the sensor cable either has a broken wire or short-circuit. The alarm A07015 "Drive: Motor temperature sensor alarm" is initiated. After the wait time in p0607 has expired, fault F07016 "Drive: Motor temperature sensor fault" is output.
- If an induction motor is connected, you can suppress fault F07016 by setting p0607 = 0. The drive then continues to operate with the data calculated in the thermal 3-mass model.
- If the motor temperature sensor set in p0600 is not connected, alarm A07820 "Temperature sensor not connected" is triggered.

9.5.12 Function diagrams and parameters

Function diagrams (see SINAMICS S120/S150 List Manual)

- 8016 Signals and monitoring functions - thermal monitoring motor, Mot_temp ZSW F/A
- 8017 Signals and monitoring functions - motor temperature model - 1 (12t)
- 9576 Terminal Module 31 (TM31) - Temperature evaluation
- 9605 Terminal Module 120 (TM120) - Temperature evaluation, channels 0 and 1
- 9606 Terminal Module 120 (TM120) - Temperature evaluation, channels 2 and 3
- 9625 Terminal Module 150 (TM150) - Temperature evaluation structure (channel 0 ... 11)
- 9626 Terminal Module 150 (TM150) - Temperature evaluation 1x2-, 3-, 4-wire (channel 0 ... 5)
- 9627 Terminal Module 150 (TM150) - Temperature evaluation 2x2-wire (channel 0 ... 11)

Overview of important parameters (see SINAMICS S120/S150 List Manual)

- r0034 CO: Thermal motor load
- r0035 CO: Motor temperature
- r0068 CO: Absolute actual current value
- p0318[0...n] Motor stall current
- p0600[0...n] Motor temperature sensor for monitoring
- p0601[0...n] Motor temperature sensor type
- p0602 Par_circuit power unit number temperature sensor
- p0603 CI: Motor temperature signal source
- p0604[0...n] Mot_temp_mod 2:sensor warning threshold
- p0605[0...n] Mot_temp_mod 1/2 threshold and temperature value
- p0606[0...n] Mot_temp_mod 2/sensor timer
- p0607[0...n] Temperature sensor fault timer
- p0608[0...3] CI: Motor temperature, signal source 2
- p0609[0...3] CI: Motor temperature, signal source 3
- p0610[0...n] Motor overtemperature response
- p0624[0...n] Motor temperature offset PT100
- p0625[0...n] Motor ambient temperature during commissioning
- p4600[0...n] Motor temperature sensor 1 sensor type
- p4601[0...n] Motor temperature sensor 2 sensor type
- p4602[0...n] Motor temperature sensor 3 sensor type
- p4603[0...n] Motor temperature sensor 4 sensor type
- r4620[0...3] Motor temperature measured

Additional parameters for TM31

- p4100 TM31 sensor type
- p4102[0...1] TM31 fault threshold / alarm threshold
- p4103 TM31 temperature evaluation delay time
- r4104.0...1 BO: TM31 temperature evaluation status
- r4105 CO: TM31 actual temperature value

Additional parameters for TM120

- p4100[0...3] TM120 temperature evaluation sensor type
- r4101[0...3] TM120 sensor resistance
- p4102[0...7] TM120 fault threshold / alarm threshold
- p4103[0...3] TM120 temperature evaluation delay time
- r4104.0...7 BO: TM120 temperature evaluation status
- r4105 [0...3] CO: TM120 actual temperature value

Additional parameters for TM150

- p4100[0...11] TM150 sensor type
- r4101[0...11] TM150 sensor resistance
- p4102[0...23] TM150 fault threshold / alarm threshold
- p4103[0...11] TM150 delay time
- r4104.0...23 BO: TM150 temperature evaluation status
- r4105[0...11] CO: TM150 actual temperature value
- p4108[0...5] TM150 terminal block measurement method
- p4109[0...11] TM150 cable resistance measurement
- p4110[0...11] TM150 cable resistance value
- p4111[0...2] TM150 group channel assignment
- r4112[0...2] CO: TM150 group actual temperature value, maximum
- r4113[0...2] CO: TM150 group actual temperature value, minimum
- r4114[0...2] CO: TM150 group actual temperature value, average
- p4117[0...2] TM150 group, sensor fault effect
- p4118[0...11] TM150 fault threshold / alarm threshold hysteresis
- p4119[0...11] TM150 activate/deactivate smoothing
- r4120[0...11] TM150 actual value smoothing time in ms
- p4121 TM150 filter, rated line frequency
- p4122[0...11] TM150 smoothing time constant

Thermal motor models

- p0318[0...n] Motor stall current
- p0335[0...n] Type of motor cooling
- p0344[0...n] Motor weight (for thermal motor type)
- p0611[0...n] I2t motor model thermal time constant
- p0612[0...n] Mot_temp_mod activation
- p0615[0...n] Mot_temp_mod 1 (I2t) fault threshold
- p0617[0...n] Stator thermally relevant iron component
- p0618[0...n] Stator thermally relevant copper component
- p0619[0...n] Rotor thermally relevant mass
- p0620[0...n] Thermal adaptation, stator and rotor resistance
- p0625[0...n] Motor ambient temperature during commissioning

Safety Integrated Basic Functions

10.1 Latest information

Important note for maintaining the operational safety of your system:

NOTICE

Danger to operational safety due to unwanted motion

Systems with safety-related characteristics are subject to special operational safety requirements on the part of the operating company. If information on a lack of product safety becomes known in the course of observing a product, this information is declared in various ways. For this reason, we publish a special newsletter containing information on product developments and features that are (or could be) relevant when operating safety-related systems.

- You should subscribe to and carefully read the corresponding newsletter in order to obtain the latest information and to allow you to modify your equipment accordingly.

To subscribe to the newsletter, please proceed as follows:

1. Go into the Internet under:
Siemens automation (<http://automation.siemens.com/>)
2. Select the desired language for the Web page.
3. Click on the menu item "Presales info".
4. Click on the menu item "Newsletter".

Note

Newsletter

You have to register and log in if you want to subscribe to any newsletters. You will be led automatically through the registration process.

5. Click on "Login / registration".
6. Login with your access data. If you do not yet have a login and password, select "Yes, I would like to register now".
You can subscribe to the individual newsletters in the following window.
7. Under the "All newsletters" heading on this page, you can see which newsletter is currently available.

10.1 Latest information

8. Open the topic "Products and solutions".

You will now be shown which newsletter is available for this particular subject area or topic. You can subscribe to the appropriate newsletter by clicking on the "Subscribe" entry. If you require more detailed information on the newsletters, then please use the supplementary function on the website.

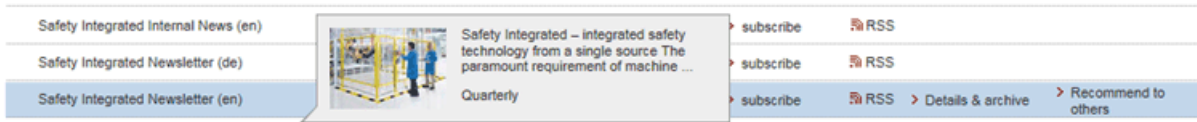

9. At the very least, register for the newsletters for the following product areas:

- Safety Integrated

10.2 General information

Note

Further references

This manual describes the Safety Integrated Basic Functions.

More information about Safety Integrated Extended Functions can be found in the SINAMICS S120 Safety Integrated Function Manual.

10.2.1 Explanations, standards and terminology

Safety Integrated

The "Safety Integrated" functions enable the implementation of highly effective application-oriented functions for man and machine protection. This innovative safety technology offers the following benefits:

- Increased safety
- More economic operation
- Greater flexibility
- Higher level of plant availability

Standards and Directives

Various standards and guidelines for safety technology must be observed. Guidelines are binding for both the manufacturer and operator of machines.

Standards generally reflect the state of the art and act as a basis for implementing safety concepts. Unlike directives, however, they are not binding.

Below is a list of standards and guidelines for safety technology.

- EC Machinery Directive 2006/42/EC
This guideline defines basic protection measures for safety technology.
- EN ISO 12100
Safety of machinery, basic terminology, general principles for design
- EN 60204-1:2006
Safety of machinery - Electrical equipment of machines - Part 1: Electrical equipment of machinery - General requirements

- IEC 61508
Functional reliability of electrical and electronic systems
This standard defines "safety integrity levels" (SIL), which not only describe a certain degree of integrity with regard to safety-oriented software but also defined, quantitative error probability ranges with regard to the hardware.
 - IEC 61800-5-2
Adjustable-speed electrical power drive systems
Part 5-2: Safety requirements - Functional
-

Note

Certifications

In conjunction with certified components, the safety functions of the SINAMICS S120 drive system fulfill the following requirements:

- Safety integrity level 2 (SIL 2) according to IEC 61508.
- Category 3 according to DIN EN ISO 13849-1
- Performance level (PL) d according to DIN EN ISO 13849-1

In addition, the SINAMICS S120 safety functions are normally certified by independent institutions. A list of currently certified components is available on request from your local Siemens office.

Note

Low-voltage directive

When operated in dry areas, SINAMICS devices with three-phase motors conform to Low-Voltage Directive 2006/95/EC.

Two-channel monitoring structure

All the main hardware and software functions for Safety Integrated are implemented in two independent monitoring channels (e.g. switch-off signal paths, data management, data comparison).

The two drive monitoring channels are implemented using the following components:

- Control Unit
- Motor Module/Power Module belonging to a drive

The monitoring functions in each monitoring channel work on the principle that a defined status must prevail before each action is carried out and a specific acknowledgment must be made after each action.

If these expectations of a monitoring channel are not fulfilled, the drive coasts to a standstill (two-channel) and an appropriate message is output.

Two-channel parameterization

Safety Integrated functions must be parameterized through two channel; this means that there is one parameter each for the 1st and 2nd channels. These two parameters must be identically parameterized.

For safety reasons, when using the STARTER commissioning tool (or SCOUT) you can only set the safety-relevant parameters of the 1st. channel offline.

To set the safety-relevant parameters of the 2nd channel, proceed as follows:

- Activate the "Copy parameters after download" checkbox and then establish an online connection to the drive unit. Perform the download and then adapt the checksums. Execute the "Copy RAM to ROM" command and then a POWER ON.
- Or establish an online connection to the drive unit first and then duplicate the parameters by clicking the "Copy parameters" button on the start screen of the configuration.

In STARTER, you can also set the safety-relevant parameters of the 2nd channel by duplicating. This is the reason that in this manual, only the parameters of the 1st channel are mentioned. You can find the associated parameters of the 2nd channel in the parameter description, e.g. in the SINAMICS S120/S150 List Manual.

Also for faults and alarms, only the fault numbers of the 1st channel are mentioned.

Switch-off signal paths

Two independent switch-off signal paths are available. All switch-off signal paths are low-active, thereby ensuring that the system is always switched to a safe state if a component fails or in the event of an open circuit.

If a fault is discovered in the switch-off signal paths, the "Safe Torque Off" function is activated and a system restart inhibited.

Monitoring cycle

The safety-relevant drive functions are executed cyclically in the monitoring cycle.

The safety monitoring cycle lasts a minimum of 4 ms. Increasing the current controller cycle (p0115) also increases the safety monitoring cycle.

Data cross-check

A cyclic cross-check of the safety-related data in the two monitoring channels is carried out.

If any data is inconsistent, a stop response is triggered with any Safety function.

Overview of important parameters (see SINAMICS S120/S150 List Manual)

- r9780 SI monitoring cycle (Control Unit)

10.2.2 Supported functions

The following Safety Integrated functions (SI functions) are available:

- **Safety Integrated Basic Functions**

The following functions are part of the standard scope of the drive and can be used without any additional license:

- Safe Torque Off (STO)

STO is a safety function that prevents the drive from restarting unexpectedly, in accordance with EN 60204-1:2006 Section 5.4.

- Safe Stop 1 (SS1, time controlled)

Safe Stop 1 is based on the "Safe Torque Off" function. This means that a Category 1 stop in accordance with EN 60204-1:2006 can be implemented.

- Safe Brake Control (SBC)

The SBC function permits the safe control of a holding brake. Special requirements:

Hardware	Constraint
Power/Motor Modules booksize format	-
Power/Motor Modules chassis format	<ul style="list-style-type: none"> • Article number ...3 or higher • A Safe Brake Adapter is also needed for this design.
Power Modules blocksize	A Safe Brake Relay is also required

• **Safety Integrated Extended Functions (including the Basic Functions)**

An additional license that will be charged is required to use the following Safety Integrated Extended Functions.

- Safe Torque Off (STO)
- Safe Stop 1 (SS1, time and acceleration controlled)
- Safe Brake Control (SBC)
- Safe Stop 2 (SS2)
- Safe Operating Stop (SOS)
- Safely Limited Speed (SLS)
- Safe Speed Monitor (SSM)
- Safe Acceleration Monitor (SAM)
- Safe Brake Ramp (SBR)
- Safe Direction (SDI)
- Safety Info Channel (SIC)
- Safely Limited Position (SLP)
- Safe referencing
- Transferring safe position values (SP)
- Safe Brake Test (SBT)

The Safety Integrated Extended Functions are described in the following documentation:

Reference: /FHS/SINAMICS S120 Safety Integrated Function Manual

10.2.3 Control possibilities

The following options for controlling Safety Integrated functions are available:

Table 10- 1 Controlling the Safety Integrated functions

	Terminals (on the Control Unit and Motor/Power Module)	PROFIsafe based on PROFIBUS or PROFINET	TM54 F	Control without selection	Onboard F-DI/F-DO (CU310-2)
Basic Functions	Yes	Yes	Yes	No	Yes ¹⁾
Extended Functions	No	Yes	Yes	SLS, SDI	Yes

¹⁾ Only the F-DI 0 can be used for the control. The F-DO is not available.

Note

PROFIsafe or TM54F

Using a Control Unit, control is possible either via PROFIsafe or TM54F. Mixed operation is not permissible.

10.2.4 Parameter, Checksum, Version, Password

Properties of Safety Integrated parameters

The following applies to Safety Integrated parameters:

- They are kept separate for each monitoring channel.
- During startup, checksum calculations (Cyclic Redundancy Check, CRC) are performed on the safety parameter data and checked. The display parameters are not contained in the CRC.
- Data storage: The parameters are stored on the non-volatile memory card.
- Factory settings for safety parameters
 - A reset of the safety parameters to the factory setting on a drive-specific basis using p3900 and p0010 = 30 is only possible when the safety functions are not enabled (p9301 = p9601 = p10010 = 0).
 - Safety parameters can be reset to the factory setting with p0970 = 5. To do so, the Safety Integrated password must be set. When Safety Integrated is enabled, this can result in faults, which in turn require an acceptance test to be performed. Then save the parameters and carry out a POWER ON.
 - A complete reset of all parameters to the factory settings (p0976 = 1 and p0009 = 30 on the Control Unit) is possible even when the safety functions are enabled (p9301 = p9601 = p10010 ≠ 0).
- The safety parameterization is password-protected against accidental or unauthorized changes.

Note

The password protection is only available online.

Checking the checksum

For each monitoring channel, the Safety parameters include one parameter for the actual checksum for the Safety parameters that have undergone a checksum check.

During commissioning, the actual checksum must be transferred to the corresponding parameter for the reference checksum. This can be done for all checksums of a drive object at the same time with parameter p9701.

Basic Functions

- r9798 SI actual checksum SI parameters (Control Unit)
- p9799 SI reference checksum SI parameters (Control Unit)
- r9898 SI actual checksum SI parameters (Motor Module)
- p9899 SI reference checksum SI parameters (Motor Module)

During each ramp-up procedure, the actual checksum is calculated via the Safety parameters and then compared with the reference checksum.

If the actual and reference checksums differ, fault F01650 or F01680 is output and an acceptance test requested.

Safety Integrated versions

The Safety firmware has a separate version ID for the Control Unit and Motor Module.

For the Basic Functions:

- r9770 SI version, drive-autonomous safety functions (Control Unit)
- r9870 SI version (Motor Module)

Password

The safety password protects the safety parameters against unintentional or unauthorized access.

In the commissioning mode for Safety Integrated (p0010 = 95), you cannot change Safety parameters until you have entered the valid Safety password in p9761 for the drives.

- When Safety Integrated is commissioned for the first time, the following applies:
 - Safety passwords = 0
 - Default setting for p9761 = 0

In other words:

The Safety password does not need to be set during first commissioning.

- In the case of a series commissioning of Safety or in the case of spare part installation, the following applies:
 - The safety password is retained on the memory card and in the STARTER project.
 - No safety password is required in the case of spare part installation.
- Change password for the drives
 - p0010 = 95 Commissioning mode.
 - p9761 = Enter "old safety password".
 - p9762 = Enter "new password".
 - p9763 = Confirm "new password".
 - The new and confirmed safety password is valid immediately.

If you need to change Safety parameters but you do not know the Safety password, proceed as follows:

1. Set the entire drive unit (Control Unit with all connected drives/components) to the factory setting.
2. Recommission the drive unit and drives.
3. Recommission Safety Integrated.

Or contact your regional Siemens office and ask for the password to be deleted (complete drive project must be made available).

Overview of important parameters for "Password" (see SINAMICS S120/S150 List Manual)

- p9761 SI password input
- p9762 SI password new
- p9763 SI password acknowledgment

10.2.5 Forced checking procedure (test stop)

Forced dormant error detection or test of the switch-off signal paths (test stop) for Safety Integrated Basic Functions

The forced dormant error detection function (test stop) at the switch-off signal paths is used to detect software/hardware faults at both monitoring channels in time and is automated by means of activation/deactivation of the "Safe Torque Off" (STO) or "Safe Stop 1" (SS1) function.

To fulfill the requirements of ISO 13849-1 regarding timely error detection, the two switch-off signal paths must be tested at least once within a defined time to ensure that they are functioning properly. This functionality must be implemented by means of forced dormant error detection (test stop), triggered either in manual mode or by the automated process.

A timer ensures that forced dormant error detection (test stop) is carried out in a timely fashion.

- p9659 SI forced dormant error detection, timer.

A forced dormant error detection (test stop) must be performed on the switch-off signal paths at least once during the time set in this parameter.

Once this time has elapsed, an alarm is output and remains active until forced dormant error detection (test stop) is carried out.

The timer returns to the set value each time the STO/SS1 function is deactivated.

When the appropriate safety devices are implemented (e.g. protective doors), it can be assumed that running machinery will not pose any risk to personnel. As a consequence, the user is only made aware of the forced checking procedure (test stop) that is required using an alarm, and is requested to perform the forced checking procedure (test stop) at the next possible opportunity. This alarm does not affect machine operation.

The user must set the time interval for carrying out forced dormant error detection (test stop) to between 0.00 and 9000,00 hours depending on the application (factory setting: 8.00 hours).

Examples of when forced dormant error detection (test stop) must be performed:

- When the drives are at a standstill after the system has been switched on (POWER ON).
- When the protective door is opened.
- At defined intervals (e.g. every 8 hours).
- In automatic mode (time and event dependent).
- The maximum time interval is one year (8760 hours).

Forced dormant error detection (test stop) can be automatically executed at POWER ON.

- If the forced dormant error detection (test stop) as well as the test of the F-DO for the CU310-2 are to be executed automatically, then set p9507.6 = 1. When testing the FD-O of the CU310-2, you must parameterize p10042 and activate the test in p10046.
- If the forced dormant error detection (test stop) of the F-DI and F-DO of the TM54F is to be executed automatically, then set p10048 = 1.
- If you have parameterized the forced dormant error detection (test stop) for POWER ON, you can still initiate a forced dormant error detection (test stop) at any time through the application.
- If the automatically initiated function cannot be correctly completed as a result of a problem (e.g. communication failure), then after the problem has been resolved, the function is automatically restarted.
- After the forced dormant error detection (test stop) has been successfully executed, the converter goes into the "Ready" state.
- Timer p9659 is automatically reset as a result of the forced dormant error detection (test stop).
- The automatic forced dormant error detection (test stop) for POWER ON does not influence the Safety Integrated functions.

10.3 Safety instructions

Additional safety instructions and residual risks

Additional safety information and residual risks not specified in this section are included in the relevant sections of this Function Manual.

DANGER

Risk minimization through Safety Integrated

Safety Integrated can be used to minimize the level of risk associated with machines and plants.

Machines and plants can only be operated safely in conjunction with Safety Integrated, however, when the machine manufacturer:

- Precisely knows and observes this technical user documentation - including the documented limitations, safety information and residual risks.
- Carefully constructs and configures the machine/plant. A careful and thorough acceptance test must then be performed by qualified personnel and the results documented.
- Implements and validates all the measures required in accordance with the machine/plant risk analysis by means of the programmed and configured Safety Integrated functions or by other means.

The use of Safety Integrated does not replace the machine/plant risk assessment carried out by the machine manufacturer as required by the EC machinery directive.

In addition to using Safety Integrated functions, further risk reduction measures must be implemented.

NOTICE

Danger to life as a result of inactive Safety Integrated functions after powering up

The Safety Integrated functions are only activated after the system has completely powered up. System startup is a critical operating state with increased risk. When accidents occur, this can result in death or severe injury.

- Make sure that the machine is safe during the system start-up.

WARNING

Regulations from EN 60204-1

The Emergency Stop function must bring the machine to a standstill according to stop category 0 or 1 (STO or SS1).

The machine must not restart automatically after EMERGENCY STOP.

When individual safety functions (Extended Functions) are deactivated, an automatic restart is permitted under certain circumstances depending on the risk analysis (except when Emergency Stop is reset). An automatic start is permitted when a protective door is closed, for example.

 **WARNING****System power-up and drive activation after changing or replacing hardware and/or software**

After hardware and/or software components have been modified or replaced, it is only permissible for the system to run up and the drives to be activated with the protective devices closed. Personnel shall not be present within the danger zone.

It may be necessary to carry out a partial or complete acceptance test or a simplified functional test after having made certain changes or replacements.

Before personnel may re-enter the hazardous area, the drives should be tested to ensure that they exhibit stable control behavior by briefly moving them in both the plus and minus directions (+/-).

Please note the following during switch-on:

The Safety Integrated functions are only available and can only be selected after the system has completely powered up.

 **WARNING****Danger to life when the drive coasts down for an STO or STOP A**

The category 0 stop function in accordance with EN 60204-1 (STO or STOP A to Safety Integrated) means that the drives are not decelerated but instead coast to standstill (the time required to coast to standstill depends on the kinetic energy).

- Carefully take this response into account when designing the protective door interlocking logic.
- For safety without encoder, you must apply other measures to ensure that the protective door remains locked until the drive has come to a standstill.

 **WARNING****Danger to life as a result of a malfunction due to an acceptance test that has not been carried out after changes to parameters have been made**

Safety Integrated functions cannot detect parameter changes made by the machine builder (OEM). Incorrect parameter changes for SI functions can result in accidents leading to death or severe injury.

- After making a change to a parameter, always carry out an acceptance test and document the values in an acceptance report.
- Only use the system or machine after the acceptance test has been successfully completed.

 **WARNING**

Danger to life as a result of different responses of the Safety Integrated functions when replacing a Motor Module or a motor

Motor Modules or the motor must be replaced with a device of the same type, as the parameter settings will otherwise lead to an incorrect response of the Safety Integrated functions. Functionality that has been modified can result in accidents leading to death or severe injury.

- Always replace a component by an identical component of precisely the same type.
- Readjust the drive involved when replacing an encoder.
- Carefully test the functionality after replacement.

 **WARNING**

Danger to life as a result of parameterized safety functions, which are only available to a restricted extent, when an internal or external fault occurs

If an internal or external fault occurs, none or only some of the parameterized safety functions are available during the STOP F response triggered by the fault.

- Carefully take this into account when parameterizing a delay time between STOP F and STOP B. This is especially true for vertical axes.

10.4 Safe Torque Off (STO)

In conjunction with a machine function or in the event of a fault, the "Safe Torque Off" (STO) function is used to safely disconnect the torque-generating energy supply to the motor.

A restart is prevented by the two-channel pulse suppression. The switching on inhibited prevents an automatic restart after deselection of STO.

The two-channel pulse suppression function integrated in the Motor Modules / Power Modules is the basis for this function.

Functional features of "Safe Torque Off"

- The function is completely integrated in the drive. It can be selected via terminals, TM54F or PROFIsafe from an external source.
- The function is drive-specific, i.e. it is available for each drive and must be individually commissioned.
- The function must be enabled via parameter.
- When the "Safe Torque Off" function is selected, the following applies:
 - The motor cannot be started accidentally.
 - The pulse suppression safely disconnects the torque-generating energy supply to the motor.
 - The power unit and motor are not electrically isolated.
- The selection/deselection of the STO function also acknowledges the safety faults when the Basic Functions are used. The standard acknowledgment mechanism must also be performed.
- Extended acknowledgement:

The selection/deselection of STO can also acknowledge the safety messages of the extended safety functions. This requires that the extended message acknowledgement is configured (p9507.0 = 1).

If in addition to the "Extended Functions", the "Basic Functions via terminals" are also enabled, in addition to selection/deselection of STO via PROFIsafe or TM54F, acknowledgement is also possible by selection/deselection of STO via terminals.
- The status of the "Safe Torque Off" function is displayed using parameters (r9772, r9872, r9773 and r9774).

WARNING

Danger to life as a result of undesirable motor movement

After the energy feed has been disconnected (STO active) the motor can undesirably move (e.g. the motor can coast down), therefore presenting risk to persons.

- Take suitable measures to prevent undesirable movement, e.g. by using a brake with safety-relevant monitoring. For additional information, see Section "Safe Brake Control (SBC) (Page 654)".

 **WARNING**

Danger to life as a result of undesirable motor movement

Undesirable motor motion can occur if 2 power transistor simultaneously become defective (breakdown of the depletion layer). This can result in accidents leading to death or severe injury.

- Take suitable measures to prevent undesirable movement, e.g. by using a brake with safety-relevant monitoring. For additional information, see Section "Safe Brake Control (SBC) (Page 654)".

1) The maximum movement can involve:

- Synchronous rotary motors: Max. movement = 180° / no. of pole pairs
- Synchronous linear motors: Max. movement = pole width

Enabling the "Safe Torque Off" function

The "Safe Torque Off" function is enabled via parameter p9601:

- STO for the Safety Integrated Basic Functions:
 - p9601 = 1 hex (Basic Functions via onboard terminals)
 - p9601 = 8 hex (Basic Functions via PROFIsafe)
 - p9601 = 9 hex (Basic Functions via PROFIsafe and onboard terminals)
 - p9601 = 40 hex (basic functions via TM54F)
 - p9601 = 41 hex (basic functions via TM54F and onboard terminals)
- STO via PROFIsafe:
 - p9601.0 = 0
 - p9601.2 = 0
 - p9601.3 = 1
- STO via PROFIsafe and onboard terminals:
 - p9601.0 = 1
 - p9601.2 = 0
 - p9601.3 = 1
- STO via TM54F:
 - p9601.0 = 0
 - p9601.2 = 0
 - p9601.3 = 0
 - p9601.6 = 1

- STO via TM54F and onboard terminals:
 - p9601.0 = 1
 - p9601.2 = 0
 - p9601.3 = 0
 - p9601.6 = 1
- STO via onboard terminals:
 - p9601.0 = 1

Selecting/deselecting "Safe Torque Off"

The following is executed when "Safe Torque Off" is selected:

- Each monitoring channel triggers safe pulse suppression via its switch-off signal path.
- A motor holding brake is closed (if connected and configured).

Deselecting "Safe Torque Off" represents an internal safety acknowledgment. The following is executed if the cause of the fault has been removed:

- Each monitoring channel cancels safe pulse suppression via its switch-off signal path.
- The Safety requirement "Close motor holding brake" is canceled. A motor holding brake is closed by the Safe Brake Control (SBC) function (if connected and configured)."
- Any pending STOP F or STOP A commands are canceled (see r9772 / r9872).
- The messages in the fault memory must also be reset using the general acknowledgment mechanism.

Note

No message during selection/deselection within p9650

If "Safe Torque Off" is selected and deselected through one channel within the time in p9650, the pulses are suppressed without a message being output.

However, if you want a message to be displayed, then you must reconfigure N01620 as an alarm or fault using p2118 and p2119.

Restart after the "Safe Torque Off" function has been selected

1. Deselect the function.
2. Set drive enables.
3. Cancel the "switching-on inhibited" and switch the drive back on.
 - 1/0 edge at input signal "ON/OFF1" (cancel "switching-on inhibited")
 - 0/1 edge at input signal "ON/OFF1" (switch on drive)

Status for "Safe Torque Off"

The status of the "Safe Torque Off" (STO) function is displayed using the parameters r9772, r9872, r9773 and r9774.

As an alternative, the status of the functions can be displayed using the configurable messages N01620 and N30620 (configured using p2118 and p2119).

Response time for the "Safe Torque Off" function

For the response times when the function is selected/deselected via input terminals, see the table in Section "Response times (Page 658)".

Internal armature short-circuit with the "Safe Torque Off" function

The function "internal armature short-circuit" can be configured together with the "STO" function.

The "STO" safety function has the higher priority when simultaneously selected. If the "STO" function is initiated, then an activated "internal armature short-circuit" is disabled.

Overview of important parameters (see SINAMICS S120/S150 List Manual)

- p0799[0...2] CU inputs/outputs, sampling time
- p9601 SI enable functions integrated in the drive (Control Unit)
- r9772[0...23] CO/BO: SI Status (Control Unit)
- r9773[0...31] CO/BO: SI Status (Control Unit + Motor Module)
- r9774[0...31] CO/BO: SI Status (group STO)
- r9780 SI monitoring cycle (Control Unit)

10.5 Safe Stop 1 (SS1, time controlled)

10.5.1 SS1 with OFF3

The "Safe Stop 1" (SS1) function allows the drive to be stopped in accordance with EN 60204-1, Stop Category 1. The drive decelerates with the OFF3 ramp (p1135) once "Safe Stop 1" is selected and switches to "Safe Torque Off" once the delay time set in p9652 has elapsed.

Note

Selection via terminals

The selection of the "Safe Stop 1" (time-controlled) function via terminals is parameterized by setting a delay > 0 in p9652. In this case, the STO function can no longer be selected directly via terminals, i.e. either STO or SS1 can be selected via terminals.

If the "Safe Stop 1" (time-controlled) function has been selected by parameterizing a delay time in p9652, STO can no longer be selected directly via terminals.

Functional features of Safe Stop 1

SS1 is enabled by p9652 (delay time) $\neq 0$.

- Setting parameter p9652 has the following effect:
 - p9652 = 0
SS1 is not enabled. Only STO can be selected via TM54F, the onboard terminals and/or PROFIsafe.
 - p9652 > 0
SS1 is enabled. Only SS1 can be selected via the onboard terminals; with PROFIsafe, a selection of SS1 and STO is possible.
- When SS1 is selected, the drive is braked along the OFF3 ramp (p1135) and STO/SBC is automatically initiated after the delay time has expired (p9652).

After the function has been selected, the delay timer runs down - even if the function is deselected during this time. In this case, after the delay time has expired, the STO/SBC function is selected and then again deselected immediately.

Note

Setting the delay time

So that the drive is able to travel down the OFF3 ramp completely and any motor holding brake present can be applied, before the pulses have been safely deleted, the delay time should be set as follows:

- Motor holding brake parameterized: Delay time $p9652 \geq p1135 + p1228 + p1217$
- Motor holding brake not parameterized: Delay time $p9652 \geq p1135 + p1228$
- The setting of parameter p1135 must be oriented towards the actual braking capability of the drive.

-
- The timer (p9652) after whose expiration STO is activated, is implemented with two channels, although deceleration along the OFF3 ramp is only one channel.

Requirement

- The Basic Functions are enabled via terminals and/or PROFIsafe:
 - p9601 = 1, 8 or 9 (hex)
- Enabling Basic Functions via TM54F
 - p9601.6 = 1
- In order that the drive can brake down to a standstill even when selected through one channel, the time in p9652 must be shorter than the sum of the parameters for the data cross-check (p9650 and p9658). Otherwise the drive will coast down after the time p9650 + p9658 has elapsed.

Status of Safe Stop 1

The status of the "Safe Stop 1" (SS1) function is displayed using the parameters r9772, r9872, r9773 and r9774.

As an alternative, the status of the function can be displayed using the configurable message N01621 (configured using p2118 and p2119).

10.5.2 SS1 with external stop

In drive line-ups (e.g. drives that are mechanically connected via the material), the drive-independent braking on the respective OFF3 ramp can cause problems. If the SS1E function is used, the safe delay time (p9562) is started when the function is selected, but no OFF3 is triggered. The higher-level controller still enters the setpoint. The controller receives the information that SS1E has been selected via the Safety Info Channel.

 WARNING
Danger to life due to unsupervised axis motion
During the unsupervised delay time, for "Safe Stop 1 (time-controlled) with external stop", unsupervised axis motion is possible.
<ul style="list-style-type: none">• If there is a hazard due to unwanted movement in your application, take measures to counter it, for example, by using a brake with safe monitoring. For more information, see Chapter "Safe Brake Control (SBC) (Page 654)".

Differences between "SS1 with OFF3" and "SS1 with external stop"

"SS1 with OFF3" and "SS1 with external stop" have the following differences:

- In order to activate "Safe Stop 1 with external stop", **additionally** set p9653 to 1.
- When SS1E is selected, the drive is **not** braked along the OFF3 ramp, but after the delay time has expired (p9652), only STO/SBC is automatically initiated.

10.5.3 Function diagrams and parameters

Function diagrams (see SINAMICS S120/S150 List Manual)

- 2810 SI Basic Functions - STO (Safe Torque Off), SS1 (Safe Stop 1)
- 2811 SI Basic Functions - STO (Safe Torque Off), safe pulse cancellation

Overview of important parameters (see SINAMICS S120/S150 List Manual)

- p1135[0...n] OFF3 ramp-down time
- p1217 Motor holding brake closing time
- p1228 Pulse suppression delay time
- p9601 SI enable functions integrated in the drive (Control Unit)
- p9652 SI Safe Stop 1 delay time (Control Unit)
- r9772.0...23 CO/BO: SI Status (Control Unit)
- r9773.0...31 CO/BO: SI Status (Control Unit + Motor Module)
- r9774.0...31 CO/BO: SI Status (group STO)

Only for "Safe Stop 1 (time-controlled) with external stop"

- p9653 SI Safe Stop 1 drive-based braking response

10.6 Safe Brake Control (SBC)

The "Safe Brake Control" function (SBC) is used to safely control holding brakes that function according to the closed-circuit principle (e.g. motor holding brake).

The opening and closing of the brake is controlled by the Motor Module / Power Module. Terminals are available for this on the device in booksize format. A Safe Brake Relay is also required for the "Safe Brake Control" in the blocksize format. A Safe Brake Adapter is required in the chassis format (starting with article numbers ending with ...3). When the Power Module is configured automatically, the Safe Brake Relay is detected and the motor holding brake type is defaulted (p1278 = 0).

Brake activation via the brake connection on the Motor Module / Safe Brake Relay (SBR) / Safe Brake Adapter (SBA) involves a safe, two-channel method.

Note

No SBC for SINAMICS HLA

SINAMICS HLA does not support Safe Brake Control.

Note

Controlling the brake via a relay for "Safe Brake Control":

If you use the "Safe Brake Control (SBC)" function, the use of relays/contactors can cause faults in the brake control when brakes are switched. For this reason, this type of control is not generally enabled.

 WARNING
--

No detection of mechanical defects

"Safe Brake Control" does not detect mechanical defects. The system does not detect whether a brake, for example, is worn or has a mechanical defect, whether it opens or closes.

A wire breakage or a short-circuit in the brake winding is only detected when the state changes, i.e. when the brake either opens or closes.
--

To detect mechanical defects, use the "Safe Brake Test (SBT)" Safety Integrated Extended Function. Detailed information can be found in the "SINAMICS Safety Integrated Function Manual".

Functional features of "Safe Brake Control"

- SBC is executed when "Safe Torque Off" (STO) is selected.
- In contrast to conventional brake control, SBC is executed via two channels.
- SBC is executed regardless of the brake control or mode set in p1215. However, SBC does not make sense for 1215 = 0 or 3.
- The function must be enabled using parameters.
- When the state changes, electrical faults, such as a short-circuit in the brake winding or wire breakage can be detected.

Enabling the "Safe Brake Control" function

The "Safe Brake Control" function is enabled via parameter p9602.

The SBC function can be used only together with STO. The selection of SBC alone is not possible.

Two-channel brake control

Note

Connecting the brake

The brake cannot be directly connected to the Motor Module in chassis format: A Safe Brake Adapter is also required.

The brake is controlled from the Control Unit. Two signal paths are available for applying the brake.

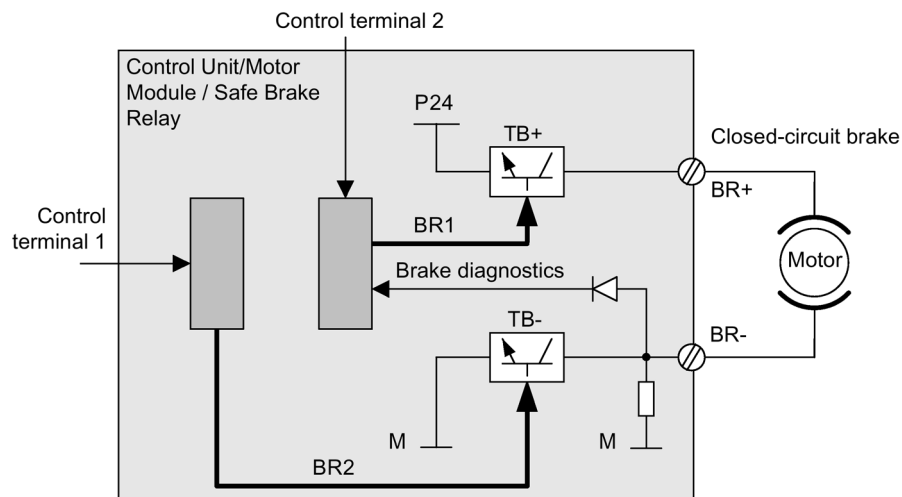

Figure 10-1 Two-channel brake control, blocksize (example)

For the "Safe Brake Control" function, the Motor/Power Module assumes a monitoring function to ensure that when the Control Unit fails or malfunctions, the brake current is interrupted therefore closing the brake.

The brake diagnosis can only reliably detect a malfunction in either of the switches (TB+, TB-) when the status changes, i.e. when the brake is released or applied.

If the Motor Module or Control Unit detects a fault, the brake current is switched off. The brake then closes and a safe state is reached.

10.6.1 SBC for Motor Modules in the chassis format

To be able to set higher power in the brakes of devices of this format, an additional Safe Brake Adapter (SBA) module is needed. For more information about connecting and wiring the Safe Brake Adapter, refer to the "SINAMICS G130/G150/S120 Chassis/S120 Cabinet Modules/S150 Safety Integrated" Function Manual.

Using parameter p9621, you can define via which digital input the relay (NO contacts) feedback signal of the Safe Brake Adapter is routed to the Control Unit.

To evaluate the feedback signal contacts, you must maintain the wait times caused by the SBA. Parameter p9622 is pre-assigned with the SBA-relay wait times:

- p9622[0] \triangleq wait time, switching on
- p9622[1] \triangleq wait time, switching off

Further functionality and the activation of the brake, i.e. reaching the safe status, are in this case the same as the above described procedure for booksize devices.

Safe Brake Control with power units in a parallel connection

Note

SBC for parallel connection of power units

Safe Brake Control with power units in a parallel connection is available if r9771.14 = 1.

If you wish to use SBC with SBA for chassis format power units connected in parallel, then it is only permissible that you connect precisely one SBA to a power unit in the parallel connection. The Safe Brake Adapter and therefore the brake are controlled via this power unit.

There are two options for registering this power unit with the system:

- Automatic brake identification when commissioning the system for the first time
 - Requirements:
 - No Safety Integrated functions enabled
 - p1215 = 0 (no motor holding brake available)
 - During the first commissioning, SINAMICS checks at which power unit an SBA is connected. If precisely one SBA is found, the number of the power unit is entered into parameter p7015.

If several SBAs are found at the parallel-connected power units, message "F07935 drive: Motor holding brake configuration error" is output.
 - For devices in the chassis format, if the SBA feedback signal (SBA_DIAG) is read in via an input of the power unit, then in addition, this digital input is automatically entered into parameter p9621.
- Manually defining the power unit
 - Enter the component number of the power unit, to which the SBA is connected, into parameter p7015. If no SBA is connected to the power unit, faults are detected when controlling the motor holding brake and fault F01630 is output.
 - In parameter p9621 (p9621 = BICO interconnection to r9872.3), enter the digital input of the power unit to which the SBA is connected and via which the SBA feedback signal (SBA_DIAG) is read in.

Note**Disconnecting the brake cable for service purposes**

As long as the brake is permanently released and not actuated, it is possible to briefly disconnect the brake cable, e.g. for service purposes, and not receive fault messages. In the case of a fault, message F07935 is only output when the brake is controlled.

10.7 Response times

The Basic Functions are executed in the monitoring cycle (p9780). PROFIsafe telegrams are evaluated in the PROFIsafe scan cycle, which corresponds to twice the monitoring clock cycle (PROFIsafe scan cycle = 2 × r9780).

Note

Actual value of the monitoring cycle (r9780)

You can only see the actual value of the monitoring cycle (r9780) if you are connected ONLINE with the drive. However, you can use the following values to roughly calculate the response times:

p0115[0] = 31.25 μs or 62.5 μs or 125 μs	r9780 = 4 ms
p0115[0] = 250 μs	r9780 = 8 ms
p0115[0] = 400 μs or 500 μs	r9780 = 16 ms

Note for understanding the tables

The drive system is the component that provides the safety functions. The designation "fault-free drive system" means that the component that provides the safety functions does not have a defect itself:

- Worst case for a fault-free drive system

For faults outside the drive system, such as e.g. faulty setpoint input from a control system, limit value violations as a result of the behavior of the motor, closed-loop control, load, etc., the "Worst case for a fault-free drive system" response time is guaranteed.

- Worst case when a fault exists

For a single fault within the drive system, such as a defect in a switch-off signal path of the power unit, a defect in an encoder actual value measurement, a defect in a microprocessor (Control Unit or Motor Module) etc., the "Worst case when a fault exists" response time is guaranteed.

10.7.1 Control of Basic Functions via terminals on the Control Unit and Motor Module (CU310-2 and CU320-2)

The following table lists the response times from the control via terminals until the response actually occurs.

Table 10- 2 Response times for control via terminals on the Control Unit and the Motor Module.

Function	Worst case for	
	Drive system has no fault	A fault is present
STO	$2 \times r9780 + t_E^{(1)}$	$3 \times r9780 + t_E^{(1)}$
SBC	$4 \times r9780 + t_E^{(1)}$	$8 \times r9780 + t_E^{(1)}$
SS1/SS1E (time-controlled) Selection until STO is initiated	$2 \times r9780 + p9652 + t_E^{(1)}$	$3 \times r9780 + p9652 + t_E^{(1)}$
SS1/SS1E (time-controlled) Selection until SBC is initiated	$4 \times r9780 + p9652 + t_E^{(1)}$	$8 \times r9780 + p9652 + t_E^{(1)}$
SS1 (time-controlled) Selection until braking is initiated	$3 \times r9780 + 2 \text{ ms} + t_E^{(1)}$	$4 \times r9780 + 2 \text{ ms} + t_E^{(1)}$

¹⁾ The following applies for t_E (debounce time of the digital input being used):

$p9651 = 0$	$t_E = 2 \times p0799$ (default = 4 ms)
$p9651 \neq 0$	$t_E = p9651 + p0799 + 1 \text{ ms}$

The minimum time for t_E is $t_{E_min} = 2 \text{ ms}$.

10.7.2 Control of Basic Functions via PROFIsafe (CU310-2 and CU320-2)

The following table lists the response times¹⁾ from receiving the PROFIsafe telegram at the Control Unit up to initiating the particular response.

Table 10- 3 Response times when controlling via PROFIsafe

Function	Worst case for	
	Drive system has no fault	A fault is present
STO	$5 \times r9780 + t_K^{(2)}$	$5 \times r9780 + t_K^{(2)}$
SBC	$6 \times r9780 + t_K^{(2)}$	$10 \times r9780 + t_K^{(2)}$
SS1/SS1E (time-controlled) Selection until STO is initiated	$5 \times r9780 + p9652 + t_K^{(2)}$	$5 \times r9780 + p9652 + t_K^{(2)}$
SS1/SS1E (time-controlled) Selection until SBC is initiated	$6 \times r9780 + p9652 + t_K^{(2)}$	$10 \times r9780 + p9652 + t_K^{(2)}$
SS1 (time-controlled) Selection until braking is initiated	$5 \times r9780 + 2 \text{ ms} + t_K^{(2)}$	$5 \times r9780 + 2 \text{ ms} + t_K^{(2)}$

- 1) The specified response times involve internal SINAMICS response times. Program run times in the F-host and the transmission time via PROFIBUS or PROFINET are not taken into account. When calculating the response times between the F-CPU and the converter, you must take into account that faults in the communication can result in a safety function only being selected after the PROFIsafe monitoring time (F_WD_Time) has expired. The PROFIsafe monitoring time (F_WD_Time) must also be included in the calculation when an error occurs.
- 2) t_K is the time for internal communication within the SINAMICS module; t_K can be determined as follows:

For isochronous communication	$t_K = T_o$ (for T_o , see parameter r2064[4])
For non-isochronous communication	$t_K = 4 \text{ ms}$ (for modules on which p2048 or p8848 ³⁾ do not exist)
	$t_K = \text{value from p2048 or p8848}^{(3)}$ (for modules, on which p2048 or p8848 ³⁾ exist)

- 3) p2048 is applicable for communication via IF1, p8848 for communication via IF2.

10.7.3 Control of Basic Functions via TM54F

The following table lists the response times from the control via TM54F until the response actually occurs.

Table 10- 4 Response times for control via TM54F

Function	Worst case for	
	Drive system has no fault	A fault is present
STO	$3 \times r_{9780} + p_{10017} + 2 \text{ ms}$	$3 \times r_{9780} + p_{10017} + 2 \text{ ms}$
SBC	$4 \times r_{9780} + p_{10017} + 2 \text{ ms}$	$8 \times r_{9780} + p_{10017} + 2 \text{ ms}$
SS1/SS1E (time-controlled) Selection until STO is initiated	$3 \times r_{9780} + p_{9652} + p_{10017} + 2 \text{ ms}$	$3 \times r_{9780} + p_{9652} + p_{10017} + 2 \text{ ms}$
SS1/SS1E (time-controlled) Selection until SBC is initiated	$4 \times r_{9780} + p_{9652} + p_{10017} + 2 \text{ ms}$	$8 \times r_{9780} + p_{9652} + p_{10017} + 2 \text{ ms}$
SS1 (time-controlled) Selection until braking is initiated	$3 \times r_{9780} + p_{10017} + 4 \text{ ms}$	$3 \times r_{9780} + p_{10017} + 4 \text{ ms}$

10.8 Control via terminals on the Control Unit and Motor/Power Module

Features

- Only for the Basic Functions
- Two-channel structure via two digital inputs (e.g. Control Unit / power unit)
- A debounce function can be applied to the terminals of the Control Unit and the Motor Module to prevent incorrect trips due to signal disturbances or test signals. The filter times are set using parameter p9651.
- Different terminal blocks depending on the format
- Automatic ANDing of up to eight digital inputs (p9620[0...7]) on the Control Unit for chassis format power units connected in parallel
- The F-DI 0 is available on the CU310-2

Overview of the safety function terminals for SINAMICS S120

The different power unit formats of SINAMICS S120 have different terminal designations for the inputs of the safety functions. These are shown in the following table.

Table 10- 5 Inputs for safety functions

Module	1st switch-off signal path (p9620[0])	2nd switch-off signal path (EP terminals)
Control Unit CU320-2	X122.1...6/X132.1...6 DI 0...7/16/17/20/21	
Single Motor Module Booksize/Booksize Compact	(see CU320-2)	X21.3 and X21.4 (on the Motor Module)
Single Motor Module/ Power Module Chassis	(see CU320-2)	X41.1 and X41.2
Double Motor Module Booksize/Booksize Compact	(see CU320-2)	X21.3 and X21.4 (motor connection X1) X22.3 and X22.4 (motor connection X2) (on the Motor Module)
Power Module Blocksize with CUA31/CUA32	(see CU320-2)	X210.3 and X210.4 (on the CUA31/CUA32)
Control Unit CU310-2	X120.3 X121.1...4	X120.4 and X120.5
Power Module Chassis with CU310-2	(see CU310-2)	X41.1 and X41.2

For further information about the terminals, see the Equipment Manuals.

Note

Function of the EP terminals

The EP terminals are only evaluated if the Safety Integrated Basic Functions are released via onboard terminals.

Description of the two-channel structure

The functions are separately selected/deselected for each drive using two terminals.

- Switch-off signal path, Control Unit (CU310-2/CU320-2)
The desired input terminal is selected via BICO interconnection (BI: p9620[0]).
- Switch-off signal path, Motor Module / Power Module (with CUA3x or CU310-2)
The input terminal is the "EP" terminal ("Enable Pulses").

Both terminals must be energized within the tolerance time p9650, otherwise a fault will be output.

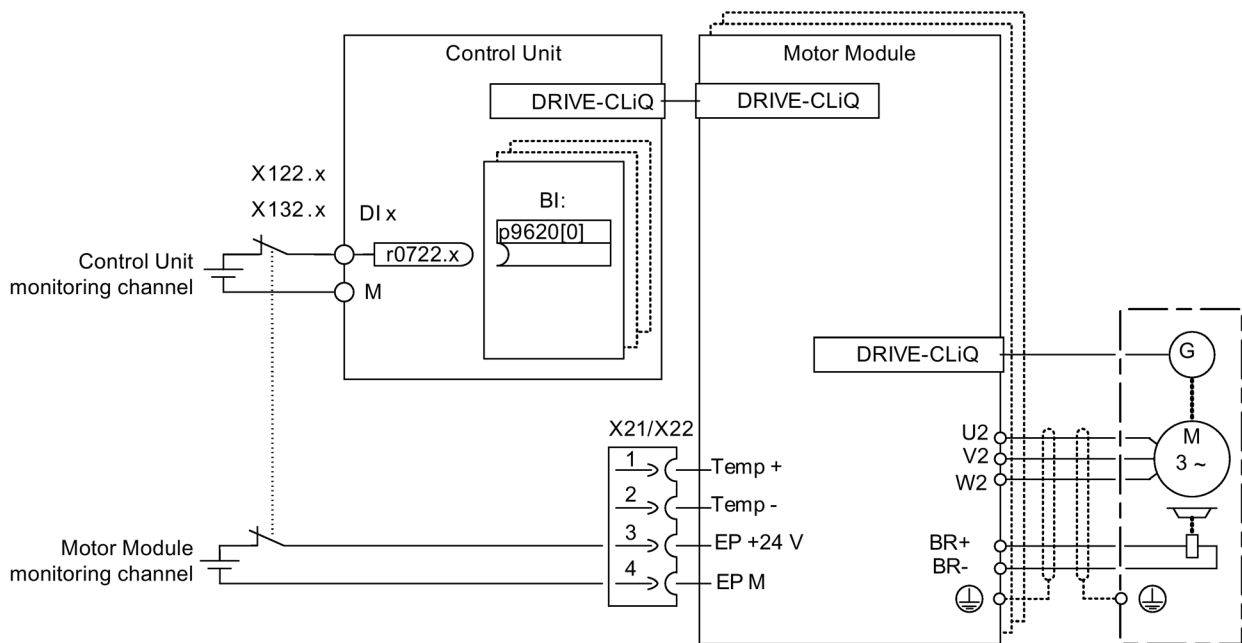

Figure 10-2 Example: Terminals for "Safe Torque Off": Example of Motor Modules Booksize and CU320-2

Grouping drives (not for CU310-2)

To ensure that the function works for more than one drive at the same time, the terminals for the corresponding drives must be grouped together as follows:

1. Switch-off signal path

Connect the p9620 parameters of all drives that belong to a group with a single DI (r0722.x) of the CU320-2.

2. Switch-off signal path (Motor Module / Power Module with CUA3x)

Wire the terminals for the individual Motor Modules / Power Modules, belonging to the group, with CUA31/CUA32.

Note

Parameterization of the grouping

The grouping must be configured (DI on Control Unit) and wired (EP terminals) identically in both monitoring channels.

Note

Response of STO for grouping

If a fault in a drive results in a "Safe Torque Off" (STO), this does not automatically mean that the other drives in the same group also switch to "Safe Torque Off" (STO).

The assignment is checked during the test for the switch-off signal paths. The operator selects "Safe Torque Off" for each group. The check is drive-specific.

Example: Terminal groups

It must be possible to select/deselect "Safe Torque Off" separately for group 1 (drives 1 and 2) and group 2 (drives 3 and 4). For this purpose, the same grouping for "Safe Torque Off" must be realized both for the Control Unit and the Motor Modules.

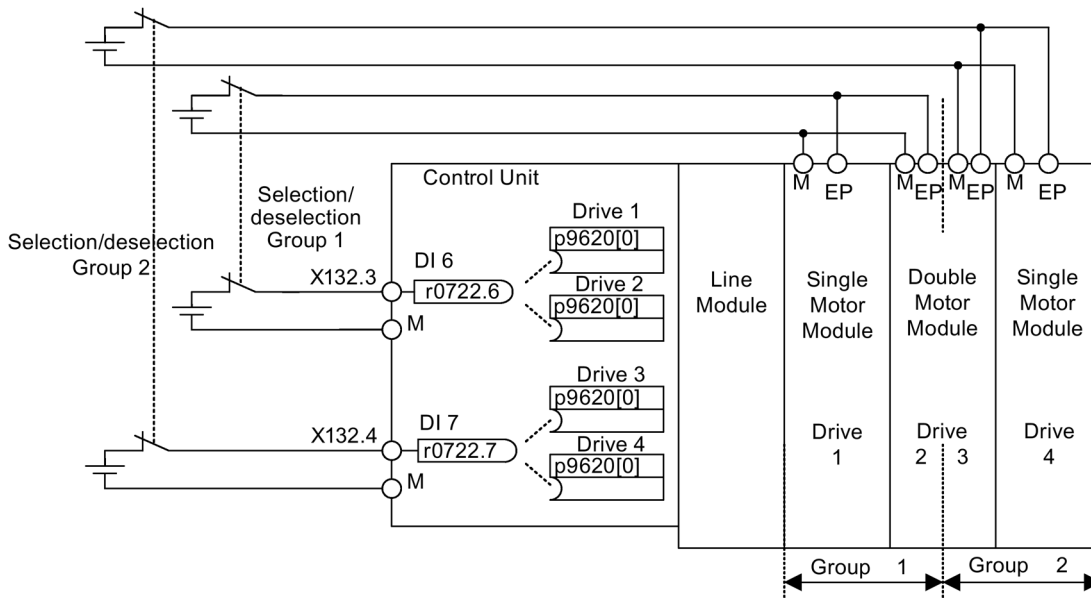

Figure 10-3 Example: Grouping terminals with Motor Modules Booksize and CU320-2

Information on the parallel connection of chassis type Motor Modules

When chassis type Motor Modules are connected in parallel, a safe AND element is created on the parallel drive object. The number of indexes in p9620 corresponds to the number of parallel chassis components in p0120.

10.8.1 Simultaneity and tolerance time of the two monitoring channels

The "Safe Torque Off" function must be selected/deselected simultaneously in both monitoring channels using the input terminals and is only effective for the associated drive.

1 signal: Deselecting the function

0 signal: Selecting the function

The time delay that is unavoidable due to mechanical switching processes, for example, can be adapted via parameters. p9650 specifies the tolerance time within which selection/deselection of the two monitoring channels must take place to be considered as "simultaneous".

Note

Parameterization of the tolerance time

In order to avoid that faults are incorrectly initiated, at these inputs the tolerance time must always be set shorter than the shortest time between two switching events (ON/OFF, OFF/ON).

If the "Safe Torque Off" function is not selected/deselected within the tolerance time, this is detected by the cross-comparison, and fault F01611 (STOP F) is output. In this case, the pulses have already been canceled as a result of the selection of "Safe Torque Off" on one channel.

Note

Timing between the switching operations

Message F01611 with fault value 1000 is output if switching operations occur too frequently. The cause depends on the type of control:

- The signals are continually changing at the F-DI.
- STO is being permanently initiated via PROFIsafe (also as subsequent response).

Within the time $5 \times p9650$, there must be at least two switching operations at the terminals or via PROFIsafe with a minimum time between them of p9650.

Additional notes regarding setting the discrepancy time are included in the "SINAMICS S120/S150 List Manual" for the C01770 and F01611 safety messages.

10.8.2 Bit pattern test

Bit pattern test of fail-safe outputs

The converter normally responds immediately to signal changes in its fail-safe inputs. This is not desired in the following case: Several control modules test their fail-safe outputs using bit pattern tests (on/off tests), in order to identify faults due to either short-circuit or cross-circuit faults. When you interconnect a fail-safe input of the converter with a fail-safe output of a control module, the converter responds to these test signals.

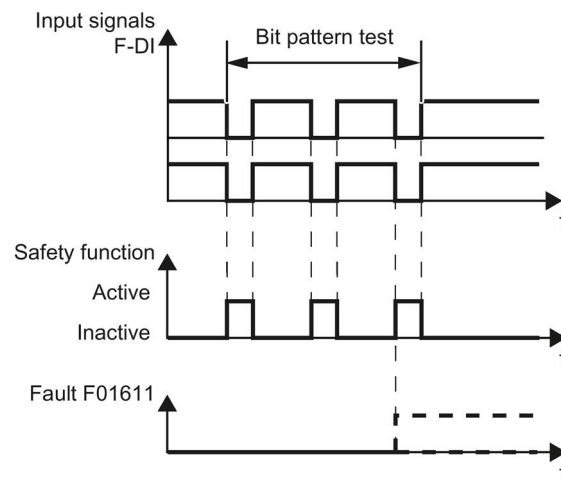

Figure 10-4 Converter response to a bit pattern test

Note

Debounce time for unwanted triggering of Safety Integrated functions

If the test pulses cause an unwanted triggering of the Safety Integrated functions, these test pulses can be suppressed using the F-DI input filter (p9651 for Basic Functions or p10017 for Extended Functions). To do this, a value must be entered in p9651 or p10017 that is greater than the duration of a test pulse.

Overview of important parameters (see SINAMICS S120/S150 List Manual)

- p9651 SI STO/SBC/SS1 debounce time (Control Unit)
- p10017 SI Motion digital inputs debounce time (processor 1)

10.9 Control via TM54F

10.9.1 Design

The TM54F is a terminal expansion module for snapping onto a DIN EN 60715 mounting rail: The TM54F features fail-safe digital inputs and outputs for controlling and signaling the states of the Safety Integrated Extended Functions.

Note

DRIVE-CLiQ line of the TM54F

- A TM54F must be connected directly to a Control Unit via DRIVE-CLiQ.
 - Each Control Unit can be assigned only one TM54F which is connected via DRIVE-CLiQ.
 - Additional DRIVE-CLiQ nodes can be operated at the TM54F, such as Sensor Modules and Terminal Modules (excluding an additional TM54F). It is not permissible that Motor Modules and Line Modules are connected to a TM54F.
 - In the case of a CU310-2 Control Unit, it is not possible to connect the TM54F to the DRIVE-CLiQ line of a Power Module. The TM54F can only be connected to the sole DRIVE-CLiQ X100 socket of the Control Unit.
-

Table 10- 6 Overview of the TM54F interfaces

Type	Number
Fail-safe digital outputs (F-DO)	4
Fail-safe digital inputs (F-DI)	10
Sensor ¹⁾ power supplies, dynamic response supported ²⁾	2
Sensor ¹⁾ power supply, no dynamic response	1
Digital inputs for checking the F-DO with activated forced checking procedure (test stop)	4

¹⁾ Sensors: Fail-safe devices for command operations and sensing (e.g. Emergency Stop pushbuttons, safety door locks, position switches, and light arrays / light curtains).

²⁾ Dynamic response: The sensor power supply is switched on and off by the TM54F when the forced dormant error detection (test stop) is active for the sensors, cable routing, and the evaluation electronics.

The TM54F provides four fail-safe digital outputs and ten fail-safe digital inputs. A fail-safe digital output consists of a 24 VDC switching output, an output switching to ground and a digital input for reading back the switching state. A fail-safe digital input is made up of 2 digital inputs.

Function diagrams (see SINAMICS S120/S150 List Manual)

- 2890 SI TM54F - overview

10.9.2 Fault acknowledgment

You have the following options of acknowledging TM54F faults after troubleshooting:

- POWER ON
- Falling edge of the signal "Internal Event ACK" with subsequent acknowledgment on the Control Unit ("fail-safe acknowledgment").

10.9.3 F-DI function

Description

Fail-safe digital inputs (F-DI) consist of 2 digital inputs. For the 2nd digital input, in addition cathode (M) of the optocoupler is fed out in order to allow the connection of an output of an F-control with switched ground (for this purpose, the anode must be connected to 24 V DC).

Parameter p10040 is used to determine whether an F-DI is operated as NC/NC or NC/NO contact. The status of each DI can be read at parameter r10051. The bits of both drive objects are logically AND'ed and return the status of the relevant F-DI.

Test signals from F-DOs and interference pulses can be filtered out using the input filter (p10017), so that they do not cause any faults.

Explanation of terms:

NC contact / NC contact: to select the safety function, a "zero level" must be present at both inputs.

NC contact/NO contact: to select the safety function, a "zero level" must be present at input 1 and a "1 level" at input 2.

The signal states at the two associated digital inputs (F-DI) must assume the same status configured in p10040 within the monitoring time set in p10002.

In order to enable forced checking procedure (test stop), connect the digital inputs of F-DI 0 ... 4 of the TM54F with the dynamic voltage supply L1+ and the digital inputs with F-DI 5 ... 9 to L2+ (for additional information on forced checking procedure (test stop), see the corresponding function description in Section "Forced checking procedure (test stop) (Page 642)").

Table 10- 7 Overview of the fail-safe inputs in the SINAMICS S120/S150 List Manual:

Module	Function diagram	Inputs
TM54F	2893	F-DI 0 4
	2894	F-DI 5 ... 9

F-DI features

- Fail-safe configuration with 2 digital inputs per F-DI
- Input filter to block test signals with an adjustable suppression time (p10017)
- Configurable connection of NC/NC or NC/NO contacts using p10040
- Status parameter r10051
- Adjustable time window for monitoring discrepancy at both digital inputs by means of parameter p10002 for all F-DIs

Note

Discrepancy time

To avoid incorrect triggering of fault messages, at these inputs the discrepancy time must always be set less than the shortest time between 2 switching events (ON/OFF, OFF/ON).

- Second digital input with additional tap of the optocoupler cathode for connecting a ground-switching output of a fail-safe controller.
- The signal states of the two digital inputs of the F-DIs are frozen at logical 0 (safety function selected) when different signal states are present within a failsafe F-DI until a safe acknowledgment has been carried out by means of an F-DI via parameter p10006 (SI acknowledgment internal event input terminal).
- The monitoring time (p10002) for the discrepancy of the two digital inputs of an F-DI may have to be increased so that switching operations do not trigger an undesired response, thereby necessitating a safe acknowledgment. Therefore, the signal states at the two associated digital inputs (F-DI) must have the same state within this monitoring time, otherwise the following fault will be output F35151 "TM54F: Discrepancy error". This requires safe acknowledgment.

 WARNING
--

Danger to life as a result of incorrect switching states due to quiescent currents in the switched-off state

In contrast to mechanical switching contacts (e.g. Emergency Stop switches), quiescent currents can still flow through semiconductor switches even when they are switched off. This can lead to false switching states if digital inputs are not connected correctly.

- | |
|--|
| <ul style="list-style-type: none">• You must observe the conditions for digital inputs/outputs specified in the relevant manufacturers documentation.• Only use outputs that have a maximum quiescent current of 0.5 mA when in the "OFF" state (according to IEC 61131 Part 2, Chapter 5.2 (2008)) |
|--|

You can find additional information on this topic in the Internet at: Parameterizing and configuring safety hardware (<http://support.automation.siemens.com/WW/view/de/39700013>)

Function diagrams (see SINAMICS S120/S150 List Manual)

- 2893 SI TM54F - fail-safe digital inputs (F-DI 0 ... F-DI 4)
- 2894 SI TM54F - fail-safe digital inputs (F-DI 5 ... F-DI 9)

Overview of important parameters (see SINAMICS S120/S150 List Manual)

- p10002 SI TM54F F-DI switchover discrepancy time
- p10017 SI TM54F digital inputs debounce time
- p10040 SI TM54F F-DI input mode
- r10051.0...9 CO/BO: SI TM54F digital inputs, status

10.9.4 Function of the F-DO

Fail-safe digital outputs (F-DO) consist of 2 digital outputs and 1 digital input that checks the switching state for the forced checking procedure (test stop). The 1st digital output switches the 24 V DC, and the 2nd digital output switches the X514 power supply (TM54F).

The status of each F-DO can be read at parameter r10052. The status of the associated DI can be read at parameter r10053 (only available for TM54F_SL (TM54F Slave Module)).

The actuator connected to the F-DO can also be tested under specific conditions as part of the forced checking procedure (test stop). See Section "Forced checking procedure (test stop) (Page 642)".

Table 10- 8 Overview of the fail-safe outputs in the SINAMICS S120/S150 List Manual:

Module	Function diagram	Outputs	Associated checking inputs
TM54F	2895	F-DO 0 ... 3	DI 20 ... 23

F-DO signal sources

A drive group contains several drives with similar characteristics. The groups are parameterized at the p10010 and p10011 parameters.

The following signals are available for interconnecting (p10042, ..., p10045) each one of the four drive groups with the F-DO:

- STO active
- SS1 active
- SS2 active
- SOS active
- SLS active
- SSM feedback active

- Safe state
- SOS selected
- Internal event
- Active SLS level bit 0
- Active SLS level bit 1
- SDI positive active
- SDI negative active
- SLP active
- Active SLP area

The following (safe state) signals can be requested via p10039[0...3] for each drive group (index 0 corresponds with drive group 1 etc.):

- STO active (power removed/pulses suppressed)
- SS1 active
- SS2 active
- SOS active
- SLS active
- SDI positive active
- SDI negative active
- SLP active

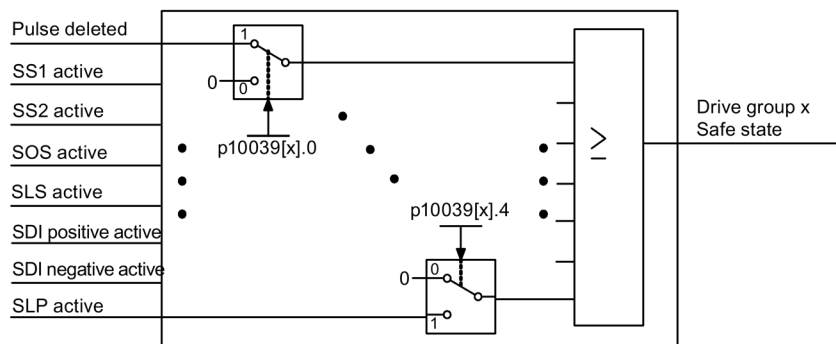

Figure 10-5 Selecting the safe state (example, Extended Functions)

The same signals (high-active) of each drive or drive group are logically linked by means of AND operation. The different signals selected via p10039 are logically OR'ed. Result of these logic operations is the "Safe State" for each drive group. You can find details in the SINAMICS S120/S150 List Manual in function diagrams 2901 (Basic Functions) or 2906 (Extended Functions).

Each F-DO supports the interconnection of up to 6 signals by way of indexing (p10042[0...5] to p10045[0...5]) and their output as logical AND operation.

Function diagrams (see SINAMICS S120/S150 List Manual)

- 2893 SI TM54F - fail-safe digital inputs (F-DI 0 ... F-DI 4)
- 2894 SI TM54F - fail-safe digital inputs (F-DI 5 ... F-DI 9)
- 2895 SI TM54F - fail-safe digital outputs (F-DO 0 ... F-DO 3), digital inputs (DI 20 ... 23)
- 2900 SI TM54F - Basic Functions control interface (p9601.2/3 = 0 & p9601.6 = 1)
- 2901 SI TM54F - Basic Functions Safe State selection
- 2902 SI TM54F - Basic Functions assignment (F-DO 0 ... F-DO 3)
- 2905 SI TM54F - Extended Functions control interface (p9601.2 = 1 & p9601.3 = 0)
- 2906 SI TM54F - Extended Functions Safe State selection
- 2907 SI TM54F - Extended Functions assignment (F-DO 0 ... F-DO 3)

Overview of important parameters (see SINAMICS S120/S150 List Manual)

- p10039[0...3] SI TM54F Safe State signal selection
- p10042[0...5] SI TM54F F-DO 0 signal sources
- p10043[0...5] SI TM54F F-DO 1 signal sources
- p10044[0...5] SI TM54F F-DO 2 signal sources
- p10045[0...5] SI TM54F F-DO 3 signal sources
- r10051.0...9 CO/BO: SI TM54F digital inputs, status
- r10052.0...3 CO/BO: SI TM54F digital outputs, status
- r10053.0...3 CO/BO: SI TM54F digital inputs, 20 ... 23 status

10.10 Commissioning the "STO", "SBC" and "SS1" functions

10.10.1 General information about commissioning safety functions

Commissioning notes

Note**Duplicating safety parameters**

For safety-relevant reasons, using the STARTER commissioning tool (or SCOUT) you can only set the safety-relevant parameters of the Control Unit offline. In order to set the safety-relevant parameters of the Motor Module, establish an online connection to the SINAMICS S120 and copy the parameters using the "Copy parameter" button on the start screen of the safety configuration into the Motor Module.

Note**Drive-specific functions**

The "STO", "SBC" and "SS1" functions are drive specific. This means that the functions must be commissioned individually for each drive.

Note**Incompatible version in the Motor Module**

If the version in the Motor Module is incompatible, the Control Unit responds as follows during the switchover to safety commissioning mode (p0010 = 95):

- Fault F01655 (SI CU: Align the monitoring functions) is output. The fault initiates stop response OFF2.
 - The Control Unit triggers a safe pulse suppression via its own safety switch-off signal path.
 - If parameterized (p1215, p9602), the motor holding brake is applied.
 - The fault can only be acknowledged after the safety functions were inhibited (p9601).
-

Requirements for commissioning the safety functions

- Commissioning of the drives must be complete.
- Non-safe pulse suppression must be present (e.g. via OFF1 = "0" or OFF2 = "0")

If the motor holding brake is connected and parameterized, the holding brake is applied.

- The terminals for "Safe Torque Off" must be wired.
- For operation with SBC, the following applies:

A motor with motor holding brake must be connected to the appropriate Motor Module connection.

Standard commissioning of the safety functions

- A commissioned project that has been uploaded to STARTER can be transferred to another drive unit keeping the existing safety parameterization.
- If the source and target devices have different firmware versions, it may be necessary to adapt the reference checksums (p9799, p9899). This is indicated by the faults F01650 (fault value: 1000) and F30650 (fault value: 1000).
- Once the project has been downloaded to the target device, an acceptance test must be carried out (see Section "Acceptance test and acceptance protocol"). This is indicated by fault F01650 (fault value: 2004).

Note

Save after project download

Once a project has been downloaded, it must be stored on the non-volatile memory card (copy from RAM to ROM).

Replacing Motor Modules with a more recent firmware version

- After a Motor Module fails, a more recent firmware version can be installed on the new Motor Module.
- If the old and new devices have different firmware versions, it may be necessary to adjust the reference checksums (p9899) (see the following table). This is indicated by fault F30650 (fault value: 1000).

No.	Parameter	Description/comments
1	p0010 = 95	Safety Integrated: set commissioning mode.
2	p9761 = "Value"	Enter the Safety password.
3	p9899 = "r9898"	Adapt the reference checksum on the Motor Module
4	p0010 ≠ 95	Safety Integrated: exit commissioning mode
5	POWER ON	Carry out a POWER ON.

Adapt the reference checksum with the safety screens of STARTER:

1. Change settings →
2. Enter password →
3. Activate settings

The checksums are automatically adapted after "activate settings".

10.10.2 Commissioning via direct parameter access

To commission the "STO", "SBC" and "SS1" functions via terminals, carry out the following steps:

Table 10-9 Commissioning the "STO", "SBC" and "SS1" functions

No.	Parameter	Description/comments
1	p0010 = 95	<p>Safety Integrated: Set commissioning mode.</p> <ul style="list-style-type: none"> • The following alarms and faults are output: <ul style="list-style-type: none"> – A01698 (SI CU: Commissioning mode active) During first commissioning only: <ul style="list-style-type: none"> – F01650 (SI CU: Acceptance test required) with fault value = 130 (no Safety parameters exist for the Motor Module). – F30650 (SI MM: Acceptance test required) with fault value = 130 (no Safety parameters exist for the Motor Module). Acceptance test and test certificate, see step 17. • The pulses are safely suppressed. • An existing and parameterized motor holding brake has already been applied. • In this mode, fault F01650 or F30650 with fault value = 2003 is output after a Safety parameter is changed for the first time. <p>This behavior applies for the entire duration of Safety commissioning, that means, the "STO" function cannot be selected/deselected while safety commissioning mode is active because this would constantly force safe pulse suppression.</p>
2	p9761 = "Value"	<p>Enter the Safety password.</p> <p>When Safety Integrated is commissioned for the first time, the following applies:</p> <ul style="list-style-type: none"> • Safety password = 0 • Default setting for p9761 = 0 <p>This means that the Safety password does not need to be set during first commissioning.</p>
3	p9601.0 = 1	<p>Enable "Safe Torque Off (STO)" function.</p>
4	p9602 = 1	<p>Enable "Safe Brake Control (SBC)" function.</p> <ul style="list-style-type: none"> • SBC cannot be used alone, but only in conjunction with one of the STO and SS1 functions.
5	p9652 > 0	<p>Enable "Safe Stop 1 (SS1)" function.</p> <ul style="list-style-type: none"> • The "Safe Stop 1" function is not activated until at least one safety monitoring function has been enabled (i.e. p9601 ≠ 0).

No.	Parameter	Description/comments
6	p9620 = "fast DI on CU" Terminal "EP"	<p>Set terminals for "Safe Torque Off (STO)".</p> <p>Wire terminal "EP" (enable pulses) on the Motor Module.</p> <ul style="list-style-type: none"> • Control Unit monitoring channel: <ul style="list-style-type: none"> By appropriately interconnecting BI: p9620 for the individual drives, the following is possible: <ul style="list-style-type: none"> – Selecting/deselecting the STO – Grouping the terminals for STO • Motor Module monitoring channel: <ul style="list-style-type: none"> By wiring the "EP" terminal accordingly on the individual Motor Modules, the following is possible: <ul style="list-style-type: none"> – Selecting/deselecting the STO – Grouping the terminals for STO <p>Note:</p> <p>The STO terminals must be grouped identically in both monitoring channels.</p>
7	p9650 = "Value"	<p>Set F-DI changeover tolerance time.</p> <p>F-DI changeover tolerance time on Control Unit</p> <ul style="list-style-type: none"> • The parameter is not changed until safety commissioning mode has been exited (i.e. when p0010 ≠ 95 is set). • Due to the different runtimes in the two monitoring channels, an F-DI changeover (e.g. selection/deselection of STO) does not take immediate effect. After an F-DI changeover, dynamic data is not subject to a data cross-check during this tolerance time.
8	p9651 = "Value"	<p>Debounce time for the fail-safe digital inputs to control STO/SBC/SS1.</p>
9	p9658 = "Value"	<p>Set transition period from STOP F to STOP A.</p> <ul style="list-style-type: none"> • STOP F is the stop response that is initiated when the data cross-check is violated as a result of fault F01611 or F30611 (SI: Defect in a monitoring channel). STOP F normally triggers "No stop response". • After the parameterized time has expired, STOP A (immediate safety pulse inhibit) is triggered by the fault F01600 or F30600 (SI: STOP A triggered). <p>The default setting for p9658 is 0 (i.e. STOP F immediately results in STOP A).</p>
10	p9659 = "Value"	<p>Time for carrying out forced dormant error detection and testing the safety switch-off paths.</p> <ul style="list-style-type: none"> • After this time has expired, the user is requested to test the switch-off paths as a result of alarm A01699 (SI CU: Necessary to test the switch-off signal paths) (i.e. select/deselect STO). • The commissioning engineer can change the time required for carrying out the forced checking procedure and testing the safety switch-off paths.
11	p9762 = "Value" p9763 = "Value"	<p>Set the new Safety password.</p> <p>Enter a new password.</p> <p>Confirm the new password.</p> <ul style="list-style-type: none"> • The new password is not valid until it has been entered in p9762 and confirmed in p9763. • As of now, you must enter the new password in p9761 so that you can change Safety parameters. • Changing the Safety password does not mean that you have to change the checksums.

No.	Parameter	Description/comments
12	p9621 = "value" p9622[0...1] = "value"	<p>Parameterize Safe Brake Adapter.</p> <ul style="list-style-type: none"> • Set with p9621 the signal source for the Safe Brake Adapter. • Set with p9622 the wait times for switching on and switching off the Safe Brake Adapter relay.
13	p9700 = 57 hex p9701 = DC hex	<p>Save and copy the Safety Integrated function parameters.</p> <p>After setting the specific parameters of the Safety Integrated Functions, they must be copied from the Control Unit into the Motor/Power Module and then activated:</p> <ul style="list-style-type: none"> • p9700 SI Motion copy function • p9701 SI Motion confirm data change
14	p0010 = 0	<p>Safety Integrated: Exit commissioning mode.</p> <ul style="list-style-type: none"> • If at least one safety monitoring function is enabled (p9601 ≠ 0), the checksums are checked: If the target checksum on the Control Unit has not been correctly adapted, then fault F01650 (SI CU: Acceptance test required) is output with fault code 2000 and it is not possible to exit the safety commissioning mode. If the target checksum on Motor Modules has not been correctly adapted, then fault F01650 (SI CU: Acceptance test required) is output with fault code 2001 and it is not possible to exit the safety commissioning mode. • If a safety monitoring function has not been enabled (p9601 ≠ 0), safety commissioning mode is exited without the checksums being checked. <p>When safety commissioning mode is exited, the following is carried out:</p> <ul style="list-style-type: none"> • A POWER ON must be performed after the initial commissioning. This is indicated with the A01693 message.
15	p0971 = 1 p0977 = 1	All drive parameters (entire drive group or only single axis) must be manually saved from RAM to ROM. This data is not saved automatically!
16	POWER ON	<p>Carry out POWER ON.</p> <p>After commissioning, a reset must be carried out with POWER ON.</p>
17	-	<p>Carry out acceptance test and create test certificate.</p> <p>Once safety commissioning is complete, the commissioning engineer must carry out an acceptance test for the enabled safety monitoring functions.</p> <p>The results of the acceptance test must be documented in an acceptance certificate.</p>

10.10.3 Safety faults

The fault messages of the Safety Integrated Basic Functions are saved in the standard message buffer and can be read out from there.

When faults associated with Safety Integrated Basic Functions occur, the following stop responses can be initiated:

Table 10- 10 Stop responses for Safety Integrated Basic Functions

Stop response	Triggered ...	Action	Effect
STOP A cannot be acknowledged	For all Safety faults with pulse suppression that cannot be acknowledged.	Trigger safe pulse suppression via the switch-off signal path for the relevant monitoring channel.	The motor coasts to a standstill or is braked by the holding brake.
STOP A	For all acknowledgeable Safety faults As a follow-up reaction of STOP F	During operation with SBC: Apply motor holding brake.	
	<p>STOP A corresponds to Stop Category 0 in accordance with EN 60204-1.</p> <p>With STOP A, the motor is switched directly to zero torque via the "Safe Torque Off (STO)" function.</p> <p>A motor at standstill cannot be started again accidentally.</p> <p>A moving motor coasts to standstill. This can be prevented by using external braking mechanisms, e.g. holding or operating brake.</p> <p>When STOP A is present, "Safe Torque Off" (STO) is active.</p>		
STOP F	If an error occurs in the data cross-check.	Transition to STOP A.	Follow-up response STOP A with adjustable delay (factory setting without delay) if one of the safety functions is selected
	<p>STOP F is permanently assigned to the data cross-check (DCC). In this way, errors are detected in the monitoring channels.</p> <p>After STOP F, STOP A is triggered.</p> <p>When STOP A is present, "Safe Torque Off" (STO) is active.</p>		

WARNING

Risk of uncontrolled axis motion

With a vertical axis or pulling load, there is a risk of uncontrolled axis movements when STOP A/F is triggered. This can be prevented by using "Safe Brake Control (SBC)" and a holding brake (not a safety brake!) with sufficient holding force.

Acknowledging the Safety faults

There are several options for acknowledging Safety faults (for more details see SINAMICS S120 Commissioning Manual):

1. Faults associated with Safety Integrated Basic Functions must be acknowledged as follows:
 - Remove the cause of the fault.
 - Deselect "Safe Torque Off" (STO).
 - Acknowledge the fault.

If the Safety commissioning mode is exited when the safety functions are switched off (p0010 = value not equal to 95 for p9601 = 0), then all the Safety faults can be acknowledged.

Once Safety commissioning mode has been selected again (p0010 = 95), all the faults that were previously present reappear.

2. The higher-level controller sets the signal "Internal Event ACK" via the PROFIsafe telegram (STW bit 7). A falling edge in this signal resets the status "Internal Event" and so acknowledges the fault.

Note

Safety faults can also be acknowledged (as with all other faults) by switching the drive unit off and then on again (POWER ON).

If this action has not eliminated the fault cause, the fault is displayed again immediately after power-up.

Description of faults and alarms

Note

The faults and alarms for SINAMICS Safety Integrated functions are described in SINAMICS S120/S150 List Manual

10.11 Acceptance test and acceptance report

Note

Acceptance test support in STARTER

After commissioning the Safety Integrated functions, you can use STARTER to create an acceptance report template containing the parameters to be documented (see STARTER > "Drive unit" > "Documentation").

Purpose

Note

Responsibilities

The machine manufacturer is responsible for carrying out and documenting the acceptance test: In Chapter "Acceptance tests (Page 690)" you will find examples how the acceptance test is carried out and documented for the individual safety functions.

10.11.1 Acceptance test structure

Authorized person, acceptance report

The test of each SI function must be carried out by an authorized person and logged in the acceptance report. The report must be signed by the person who carried out the acceptance test. Access rights to SI parameters must be protected by a password. This procedure must be documented in the acceptance report - the password itself must not appear there. Authorized in this sense refers to a person who has the necessary technical training and knowledge of the safety functions and is authorized by the machine manufacturer to carry out the acceptance test.

Note

Further information

- Note the information in Section "Commissioning the "STO", "SBC" and "SS1" functions (Page 674)".
- The acceptance report presented below is both an example and recommendation.
- An acceptance report template in electronic format is available at your local Siemens sales office.

Note

PFH values

- The PFH values of the individual SINAMICS S120 safety components can be found at: <http://support.automation.siemens.com/WW/view/en/76254308>
- The PFH values of all safety components from Siemens are available in the "Safety Evaluation Tool", see www.siemens.de/safety-evaluation-tool

Necessity of an acceptance test

A complete acceptance test (as described in this section) is required after initial commissioning of Safety Integrated functionality on a machine. The acceptance tests must be carried out for each individual drive. Safety-related function expansions, transfer of the commissioning settings to other series machines, hardware changes, software upgrades or similar, permit the acceptance test to be performed with a reduced scope if necessary. A summary of conditions which determine the necessary test scope or proposals in this context is provided below.

Requirements for the acceptance test

- The machine is properly wired.
- All safety equipment such as protective door monitoring devices, light barriers or emergency limit switches are connected and ready for operation.
- Commissioning of the open-loop and closed-loop control must be completed, because the over-travel distance may otherwise change as a result of a changed dynamic response of the drive control. These include, for example:
 - Configuration of the setpoint channel
 - Position control in the higher-level controller
 - Drive control

10.11.1.1 Content of the complete acceptance test

A) Documentation

Documentation of the machine and safety functions

1. Machine description (with overview)
2. Specification of the controller (if this exists)
3. Configuration diagram
4. Function table:
 - Active monitoring functions depending on the operating mode and the protective door
 - Other sensors with protective functions
 - The table is part or is the result of the configuring work
5. SI functions for each drive
6. Information about safety equipment

B) Functional testing of safety functions

Detailed function test and evaluation of SI functions used. For some functions this contains trace recordings of individual parameters. The procedure is described in detail in section Acceptance tests (Page 690).

When testing the functions STO, SS1 and SBC, you do not have to make any trace recording.

C) Functional testing of the forced checking procedure

Testing the forced checking procedure of the safety functions on each drive (for each control type).

- Testing the forced checking procedure of the safety function on the drive
 - If you are using Basic Functions, you need to activate and then deactivate STO once again.
 - If you are using Extended Functions, you need to carry out a test stop / forced checking procedure.

D) Conclusion of the report

Report of the commissioning status tested and countersignatures

1. Inspection of SI parameters
2. Logging of checksums (for each drive)
3. Issuing of the Safety password and documenting this process (do not specify the Safety password in the report!)
4. RAM to ROM backup, upload of project data to STARTER and backup of the project
5. Countersignature

10.11.1.2 Content of the partial acceptance test

A) Documentation

Documentation of the machine and safety functions

1. Extending/changing the hardware data
2. Extending/changing the software data (specify version)
3. Extending/changing the configuration diagram
4. Extending/changing the function table:
 - Active monitoring functions depending on the operating mode and the protective door
 - Other sensors with protective functions
 - The table is part or is the result of the configuring work
5. Extending/changing the SI functions per drive
6. Extending/changing the specifications of the safety equipment

B) Functional testing of safety functions

Detailed function test and evaluation of SI functions used. For some functions this contains trace recordings of individual parameters. The procedure is described in detail in section Acceptance tests (Page 690).

The function test can be left out if no parameters of the individual safety functions have been changed. In the case that only parameters of individual functions have been changed, only these functions need to be tested anew.

When testing the functions STO, SS1 and SBC, you do not have to make any trace recording.

C) Functional testing of the forced dormant error detection

Testing the forced dormant error detection of the safety functions on each drive (for each control type).

- Testing the forced dormant error detection of the safety function on the drive
 - If you are using Basic Functions, you need to activate and then deactivate STO once again.
 - If you are using Extended Functions, you need to carry out a test stop / forced dormant error detection.

D) Functional testing of actual value acquisition

1. General testing of actual value acquisition

- After exchanging the component, initial activation and brief operation in both directions.

**WARNING****Risk through process**

During this process, all personnel must keep out of the danger area.

2. Test of fail-safe actual value acquisition

- Only necessary if Extended Functions are used.
- If the motion monitoring functions are activated (e.g. SLS or SSM with hysteresis), briefly operate the drive in both directions.

E) Conclusion of the report

Report of the commissioning status tested and countersignatures

1. Extension of checksums (for each drive)
2. Countersignature

10.11.1.3 Test scope for specific measures

Scope of partial acceptance tests for specific measures

The measures and points specified in the table refer to the information provided in Section Content of the partial acceptance test (Page 684).

Table 10- 11 Scope of partial acceptance tests for specific measures

Measure	A) Documentation	B) Functional testing of safety functions	C) Functional testing of the forced dormant error detection	D) Functional testing of actual value acquisition	E) Conclusion of the report
Replacement of the Control Unit / power unit hardware	Yes, Points 1 and 2	No	Yes, only Point 1	Yes, only Point 1	Yes
Replacement of the Power Module or Safe Brake Relay	Yes, Points 1 and 2	Yes, Points 1 or 2 and 3	Yes, only Point 1	Yes, only Point 1	Yes
Firmware - upgrade (CU / power unit / Sensor Modules)	Yes, only Point 2	Yes, if new safety functions are to be used	Yes	Yes, only Point 1	Yes
Change to a single parameter of a safety function (e.g. SLS limit)	Yes, Points 4 and 5.	Yes, test the appropriate function	No	Yes	Yes
Transfer of project data to other machines (series commissioning)	Yes	Yes, but only testing of the selection of the safety functions	Yes	Yes	Yes
New firmware version for SIMOTION D	Yes, only Point 2	Yes, if new safety functions are to be used	Yes	Yes, only Point 1	Yes

10.11.2 Safety logbook

The "Safety Logbook" function is used to detect changes to safety parameters that affect the associated CRC sums. CRCs are only generated when p9601 (SI enable, functions integrated in the drive CU/Motor Module) is > 0.

Data changes are detected when the CRCs of the SI parameters change. Each SI parameter change that is to become active requires the reference CRC to be changed so that the drive can be operated without SI faults. In addition to functional safety changes, safety changes as a result of hardware being replaced can be detected when the CRC has changed.

The following changes are recorded by the safety logbook:

- Functional changes are recorded in the checksum r9781[0]:
 - Functional cyclic redundancy checks of the basic safety functions integrated in the drive (p9799, SI setpoint checksum SI parameters CU), for each axis.
 - Enable drive-integrated functions (p9601)

10.11.3 Documentation

Table 10- 12 Machine description and overview diagram

Designation	
Type	
Serial number	
Manufacturer	
End customer	
Electrical axes	
Other axes	
Spindles	
Overview diagram of machine	

Table 10- 13 Values from relevant machine data

Parameter Control Unit		FW version	-
		r0018 =	-
Parameter Motor Modules	Drive number	FW version	SI version
		-	r9770 =
		r0128 =	r9870 =
		r0128 =	r9870 =
		r0128 =	r9870 =
		r0128 =	r9870 =
		r0128 =	r9870 =
		r0128 =	r9870 =
	Drive number	SI monitoring clock cycle Control Unit	SI monitoring clock cycle Motor Module
Parameter Motor Modules		r9780 =	r9880 =
		r9780 =	r9880 =
		r9780 =	r9880 =
		r9780 =	r9880 =
		r9780 =	r9880 =
		r9780 =	r9880 =
Safety Integrated checksums			
Basic Functions	Drive number	SI reference checksum SI parameters (Control Unit)	SI reference checksum SI parameters (Motor Module)
		p9799 =	p9899 =

Table 10- 14 SI functions for each drive

Drive number	SI function

10.11.4 Acceptance tests

10.11.4.1 General information about acceptance tests

Note

Conditions for the acceptance test

As far as possible, the acceptance tests are to be carried out at the maximum possible machine speed and acceleration rates to determine the maximum braking distances and braking times that can be expected.

Note

Non-critical alarms

When evaluating the alarm buffer you can tolerate the following alarms:

- A01697 SI Motion: Motion monitoring test required
- A01796 SI Motion CU: Waiting for communication

These alarms occur after every system startup and can be evaluated as non-critical. You do not need to include these alarms in the acceptance report.

10.11.4.2 Acceptance test for Safe Torque Off (STO)

No.	Description	Status
Note: The acceptance test must be individually performed for each configured control. The control can be realized via TM54F, onboard terminals (CU310-2) or via PROFIsafe.		
1.	Initial state <ul style="list-style-type: none"> • Drive in the "Ready" state (p0010 = 0) • STO function enabled (onboard terminals/PROFIsafe/TM54F) • No safety faults and alarms (r0945[0...7], r2122[0...7]); see note "non-critical alarms" at the beginning of Section "Acceptance test". • r9772.17 = 0 (STO deselection via terminals - DI CU / EP terminal Motor Module); only relevant for STO via terminal • r9772.20 = 0 (STO deselection via PROFIsafe); only relevant for STO via PROFIsafe • r9773.0 = r9773.1 = 0 (STO deselected and inactive - drive) • r9774.0 = r9774.1 = 0 (STO deselected and inactive - group); only relevant for grouping 	
2.	Run the drive <ul style="list-style-type: none"> • Check whether the correct drive is operational Select STO when you issue the traversing command and check the following: <ul style="list-style-type: none"> • The drive coasts to a standstill or is braked and stopped by the mechanical brake. • No Safety faults and alarms (r0945[0...7], r2122[0...7]) • r9772.17 = 1 (STO selection via terminal - DI CU / EP terminal Motor Module); only relevant for STO via terminal • r9772.20 = 1 (STO selection via PROFIsafe); only relevant for STO via PROFIsafe • r9773.0 = r9773.1 = 1 (STO selected and active – drive) • r9774.0 = r9774.1 = 1 (STO selected and active – group); only relevant for grouping 	
3.	Deselect STO and check the following: <ul style="list-style-type: none"> • No Safety faults and alarms (r0945[0...7], r2122[0...7]) • r9772.17 = 0 (STO deselection via terminals - DI CU / EP terminal Motor Module); only relevant for STO via terminal • r9772.20 = 0 (STO deselection via PROFIsafe); only relevant for STO via PROFIsafe • r9773.0 = r9773.1 = 0 (STO deselected and inactive – drive) • r9774.0 = r9774.1 = 0 (STO deselected and inactive – group); only relevant for grouping 	
4.	Acknowledge switch-on inhibit and run the drive. Check whether the correct drive is operational.	

10.11.4.3 Acceptance test for Safe Stop 1, time controlled (SS1)

No.	Description	Status
Note:		
The acceptance test must be individually performed for each configured control.		
The control can be realized via TM54F, onboard terminals (CU310-2) or via PROFIsafe.		
1.	Initial state	
	<ul style="list-style-type: none"> • Drive in the "Ready" state (p0010 = 0) 	
	<ul style="list-style-type: none"> • STO function enabled (onboard terminals/PROFIsafe/TM54F) 	
	<ul style="list-style-type: none"> • SS1 function enabled (p9652 > 0) 	
	<ul style="list-style-type: none"> • Only for "SS1 with external stop": p9653 = 1 	
	<ul style="list-style-type: none"> • No safety faults and alarms (r0945[0...7], r2122[0...7]); see note "non-critical alarms" at the beginning of Section "Acceptance test". 	
	<ul style="list-style-type: none"> • r9772.22 = 0 (SS1 deselection via terminals – DI CU / EP terminal Motor Module); only relevant for SS1 via terminal 	
	<ul style="list-style-type: none"> • r9772.23 = 0 (SS1 deselection via PROFIsafe); only relevant for SS1 via PROFIsafe 	
	<ul style="list-style-type: none"> • r9773.0 = r9773.1 = 0 (STO deselected and inactive – drive) 	
	<ul style="list-style-type: none"> • r9773.5 = r9773.6 = 0 (SS1 deselected and inactive – drive) 	
	<ul style="list-style-type: none"> • r9774.0 = r9774.1 = 0 (STO deselected and inactive – group); only relevant for grouping 	
	<ul style="list-style-type: none"> • r9774.5 = r9774.6 = 0 (SS1 deselected and inactive – group); only relevant for grouping 	
2.	Run the drive	
	Check whether the correct drive is operational	
	Select SS1 when you issue the traversing command and check the following:	
	<ul style="list-style-type: none"> • Drive brakes along the OFF3 ramp (p1135) (not in the case of SS1 with external stop) 	
	Before the expiry of the SS1 delay time (p9652), the following applies:	
	<ul style="list-style-type: none"> • r9772.22 = 1 (SS1 selection via terminals – DI CU / EP terminal Motor Module); only relevant for SS1 via terminal 	
	<ul style="list-style-type: none"> • r9772.23 = 1 (SS1 selection via PROFIsafe); only relevant for SS1 via PROFIsafe 	
	<ul style="list-style-type: none"> • r9773.0 = r9773.1 = 0 (STO deselected and inactive – drive) 	
	<ul style="list-style-type: none"> • r9773.5 = r9773.6 = 1 (SS1 selected and active – drive) 	
	<ul style="list-style-type: none"> • r9774.0 = r9774.1 = 0 (STO deselected and inactive - group); only relevant for grouping 	
	<ul style="list-style-type: none"> • r9774.5 = r9774.6 = 1 (SS1 selected and active - group); only relevant for grouping 	
	STO is initiated after expiry of the SS1 delay time (p9652).	
	<ul style="list-style-type: none"> • No Safety faults and alarms (r0945[0...7], r2122[0...7]) 	
	<ul style="list-style-type: none"> • r9773.0 = r9773.1 = 1 (STO selected and active – drive) 	
	<ul style="list-style-type: none"> • r9773.5 = r9773.6 = 1 (SS1 selected and active – drive) 	
	<ul style="list-style-type: none"> • r9774.0 = r9774.1 = 1 (STO selected and active – group); only relevant for grouping 	
	<ul style="list-style-type: none"> • r9774.5 = r9774.6 = 1 (SS1 selected and active - group); only relevant for grouping 	

No.	Description	Status
3.	Canceling SS1 <ul style="list-style-type: none"> <li data-bbox="240 327 1249 363">• No Safety faults and alarms (r0945[0...7], r2122[0...7]) <li data-bbox="240 374 1249 449">• r9772.22 = 0 (SS1 deselection via terminals – DI CU / EP terminal Motor Module); only relevant for SS1 via terminal <li data-bbox="240 459 1249 495">• r9772.23 = 0 (SS1 deselection via PROFIsafe); only relevant for SS1 via PROFIsafe <li data-bbox="240 506 1249 542">• r9773.0 = r9773.1 = 0 (STO deselected and inactive – drive) <li data-bbox="240 553 1249 589">• r9773.5 = r9773.6 = 0 (SS1 deselected and inactive – drive) <li data-bbox="240 600 1249 636">• r9774.0 = r9774.1 = 0 (STO deselected and inactive – group); only relevant for grouping <li data-bbox="240 646 1249 683">• r9774.5 = r9774.6 = 0 (SS1 deselected and inactive – group); only relevant for grouping 	
4.	Acknowledge switch-on inhibit and run the drive. Check whether the correct drive is operational.	

10.11.4.4 Acceptance test for "Safe Brake Control" (SBC)

No.	Description	Status
Note: The acceptance test must be individually performed for each configured control. The control can be realized via TM54F, onboard terminals (CU310-2) or via PROFIsafe.		
1.	Initial state <ul style="list-style-type: none"> • Drive in the "Ready" state (p0010 = 0) • STO function enabled (onboard terminals/PROFIsafe/TM54F) • SBC function enabled (p9602 = 1) • Brake as in sequence control or brake always released (p1215 = 1 or p1215 = 2) • No safety faults and alarms (r0945[0...7], r2122[0...7]); see note "non-critical alarms" at the beginning of Section "Acceptance test". • r9773.4 = 0 (SBC not requested - drive) • r9774.4 = 0 (SBC not requested - group); only relevant for grouping • r9773.1 = 0 (STO inactive – drive) • r9774.1 = 0 (STO inactive – group); only relevant for grouping 	
2.	Run drive (if applied, brake is released) <ul style="list-style-type: none"> • Check whether the correct drive is operational Select STO/SS1 when you issue the traversing command and check the following: <ul style="list-style-type: none"> • The brake is applied (for SS1 the drive is previously decelerated along the OFF3 ramp) • No Safety faults and alarms (r0945[0...7], r2122[0...7]) • r9773.4 = 1 (SBC not requested – drive) • r9774.4 = 1 (SBC not requested – group); only relevant for grouping • r9773.1 = 1 (STO inactive – drive) • r9774.1 = 1 (STO inactive – group); only relevant for grouping 	
3.	Deselect STO and check the following: <ul style="list-style-type: none"> • No Safety faults and alarms (r0945[0...7], r2122[0...7]) • r9773.4 = 0 (SBC not requested – drive) • r9774.4 = 0 (SBC not requested – group); only relevant for grouping • r9773.1 = 0 (STO inactive – drive) • r9774.1 = 0 (STO inactive – group); only relevant for grouping 	
4.	Acknowledge switch-on inhibit and run the drive. Check whether the correct drive is operational.	

10.11.5 Completion of certificate

SI parameters

	Specified values checked?	
	Yes	No
Control Unit		
Motor Module		

Checksums

Basic functions			
Drive name	Drive number	SI reference checksum SI parameters (Control Unit)	SI reference checksum SI parameters (Motor Module)
		p9799 =	p9899 =
		p9799 =	p9899 =
		p9799 =	p9899 =
		p9799 =	p9899 =
		p9799 =	p9899 =
		p9799 =	p9899 =

Drive name	Drive number	SI reference checksum SI parameters (Control Unit)	SI reference checksum SI parameters (Motor Module)
		p9399[0] = p9399[1] =	p9729[0] = p9729[1] = p9729[2] =
		p9399[0] = p9399[1] =	p9729[0] = p9729[1] = p9729[2] =
		p9399[0] = p9399[1] =	p9729[0] = p9729[1] = p9729[2] =
		p9399[0] = p9399[1] =	p9729[0] = p9729[1] = p9729[2] =
		p9399[0] = p9399[1] =	p9729[0] = p9729[1] = p9729[2] =
		p9399[0] = p9399[1] =	p9729[0] = p9729[1] = p9729[2] =

Safety logbook

	Functional¹⁾
Checksum for functional tracking of changes	r9781[0] =
Checksum for hardware dependent tracking of changes	r9781[1] =
Time stamp for functional tracking of changes	r9782[0] =
Time stamp for hardware dependent tracking of changes	r9782[1] =

1) These parameters can be found in the expert list of the Control Unit.

Data backup

	Storage medium			Storage location
	Type	Designation	Date	
Parameter				
PLC program				
Circuit diagrams				

Countersignatures

Commissioning engineer

This confirms that the tests and checks have been carried out properly.

Date	Name	Company/dept.	Signature

Machine manufacturer

This confirms that the parameters recorded above are correct.

Date	Name	Company/dept.	Signature

10.12 Overview of parameters and function diagrams

Function diagrams (see SINAMICS S120/S150 List Manual)

- 2800 SI Basic Functions - Parameter manager
- 2802 SI Basic functions - Monitoring functions and faults/alarms
- 2804 SI Basic Functions - SI status CU, MM, CU+MM and status group STO
- 2806 SI Basic Functions - S_STW1/2 safety control word 1/2 and S_ZSW1/2 safety status word 1/2
- 2810 SI Basic Functions - STO (Safe Torque Off), SS1 (Safe Stop 1)
- 2811 SI Basic Functions - STO (Safe Torque Off), safe pulse cancellation
- 2814 SI Basic Functions - SBC (Safe Brake Control), SBA (Safe Brake Adapter)

Overview of important parameters (see SINAMICS S120/S150 List Manual)

Table 10- 16 Parameters for Safety Integrated

Parameters	Name	Changeable to
p9601	SI enable safety functions	Safety Integrated commissioning (p0010 = 95)
p9602	SI enable safe brake control	
p9610	SI PROFIsafe address (Control Unit)	
p9620	SI signal source for Safe Torque Off	
p9650	SI SGE changeover, tolerance time (Motor Module)	
p9651	SI STO/SBC/SS1 debounce time (Control Unit)	
p9652	SI Safe Stop 1 delay time	
p9658	SI transition time STOP F to STOP A	
p9659	SI timer for the forced checking procedure	
p9761	SI password input	In every operating mode
p9762	SI password new	Safety Integrated commissioning (p0010 = 95)
p9763	SI password acknowledgment	
r9770[0...2]	SI version safety function integrated in the drive	-
r9771	SI shared functions	-
r9772	SI CO/BO: Status	-
r9773	SI CO/BO: Status (Control Unit + Motor Module)	-
r9774	SI CO/BO: Status (Safe Torque Off group)	-
r9780	SI monitoring clock cycle	-
r9794	SI crosswise comparison list	-
r9795	SI diagnostics for STOP F	-
r9798	SI actual checksum SI parameters	-
p9799	SI reference checksum SI parameters	Safety Integrated commissioning
p10039[0...3]	SI TM54F Safe State signal selection	

Parameters	Name	Changeable to
p10040	SI TM54F F-DI input mode	(p0010 = 95)
p10041	SI TM54F F-DI test enable	
p10042[0...5]	SI TM54F F-DO 0 signal sources	
p10043[0...5]	SI TM54F F-DO 1 signal sources	
p10044[0...5]	SI TM54F F-DO 2 signal sources	
p10045[0...5]	SI TM54F F-DO 3 signal sources	
p10046	SI TM54F F-DO feedback signal input activation	
p10047[0...3]	SI TM54F F-DO test stop mode	
p10048	SI TM54F F-DI F-DO test stop configuration	
r10051.0...9	CO/BO: SI TM54F digital inputs, status	
r10052.0...3	CO/BO: SI TM54F digital outputs, status	
r10053.0...3	CO/BO: SI TM54F digital inputs, 20 ... 23 status	
r10054	SI TM54F fail-safe events active	
r10055	SI TM54F drive-specific communication status	
r10056.0	CO/BO: SI TM54F status	
p10061	SI TM54F password input	
p10062	SI TM54F password new	
p10063	SI TM54F password confirmation	
r10070	SI TM54F module identification	-
r10090[0...3]	SI TM54F version	-

Communication

11.1 Communication according to PROFIdrive

PROFIdrive is the PROFIBUS and PROFINET profile for drive technology with a wide range of applications in production and process automation systems.

PROFIdrive is independent of the bus system used (PROFIBUS, PROFINET).

Note

PROFIdrive for drive technology is standardized and described in the following document:

- PROFIdrive – Profile Drive Technology,
PROFIBUS User Organization e. V.
Haid-und-Neu-Straße 7, D-76131 Karlsruhe,
Internet: (<http://www.profibus.com>)
 - IEC 61800-7
-

PROFIdrive device classes

Table 11- 1 PROFIdrive device classes

PROFIdrive	PROFIBUS DP	PROFINET IO
Peripheral device (P device)	DP slave	IO Device
Motion controller (higher-level controller or host of the automation system)	Class 1 DP master	IO Controller
Supervisor (engineering station)	Class 2 DP master	IO Supervisor

- Drive unit (PROFIBUS: Slave, PROFINET IO: IO Device)
Example: CU320-2 Control Unit
- Controller (PROFIBUS: Master Class 1, PROFINET IO: IO Controller)
A Controller is typically a higher-level control in which the automation program runs.
Example: SIMATIC S7 and SIMOTION
- Supervisor (PROFIBUS: Master Class 2, PROFINET IO: IO Supervisor)
Devices for configuring, commissioning, operator control and monitoring while the bus is in operation and devices which only exchange non-cyclic data with drive units and controllers.
Examples: Programming devices, human machine interfaces

Properties of the Controller, Supervisor and drive units

Table 11- 2 Properties of the Controller, Supervisor and drive units

Properties	Controller	Supervisor	Drive unit
As bus node	Active		Passive
Send messages	Permitted without external request		Only possible on request by the Controller
Receive messages	Possible without any restrictions		Only receive and acknowledge permitted

Communication types

4 communication types are defined in the PROFIdrive profile:

- **Cyclic data exchange via a cyclic data channel**
Motion control systems require cyclically updated data in operation for open-loop and closed-loop control tasks. This data must be sent to the drive units in the form of setpoints or transmitted from the drive units in the form of actual values, via the communications system. Transmission of this data is usually time-critical.
- **Acyclic data exchange via an acyclic data channel**
An acyclic parameter channel for exchanging parameters between the control/supervisor and drive units is additionally available. Access to this data is not time-critical.
- **Alarm channel**
Alarms are output on an event-driven basis, and show the occurrence and expiry of error states.
- **Isochronous mode**

Interface IF1 and IF2

The CU320-2 Control Unit can communicate via two different interfaces (IF1 and IF2).

Note

Ethernet interface X127 is intended for commissioning and diagnostics.

Do not use this interface for other purposes (e.g. field bus communication) and ensure that X127 (e.g. for service) is always accessible.

Table 11- 3 Properties of IF1 and IF2

	IF1	IF2
PROFIdrive and SIEMENS telegram	Yes	No
Free telegram	Yes	Yes
Isochronous mode	Yes	Yes
Drive object types	All	All
Can be used for	PROFINET IO, PROFIBUS DP, SINAMICS Link, PN Gate, Ethernet/IP	PROFINET IO, PROFIBUS DP, CANopen, SINAMICS Link, PN Gate, Ethernet/IP
Cyclic operation	Yes	Yes
PROFIsafe	Yes	Yes

Note

For additional information on the IF1 and IF2 interfaces, see section "Parallel operation of communication interfaces (Page 716)" in this manual.

11.1.1 PROFIdrive application classes

There are different application classes for PROFIdrive according to the scope and type of the application processes. PROFIdrive features a total of six application classes, the three most important are discussed here.

Selection of telegrams depending on the PROFIdrive application class

The following Table provides an overview of which telegram can be used reach which PROFIdrive application class:

Table 11-4 Selection of telegrams depending on the PROFIdrive application class

Telegram (p0922 = x)	Description	Class 1	Class 3	Class 4
1	Speed setpoint, 16-bit	x		
2	Speed setpoint, 32-bit	x		
3	Speed setpoint, 32-bit with 1 position encoder			x
4	Speed setpoint, 32-bit with 2 position encoders			x
5	Speed setpoint, 32-bit with 1 position encoder and DSC			x
6	Speed setpoint, 32-bit with 2 position encoders and DSC			x
7	Positioning, telegram 7 (basic positioner)		x	
9	Positioning, telegram 9 (basic positioner with direct input)		x	
20	Speed setpoint, 16-bit VIK-NAMUR	x		
81	Encoder telegram, 1 encoder channel			x
82	Extended encoder telegram, 1 encoder channel + actual speed value 16-bit			x
83	Extended encoder telegram, 1 encoder channel + actual speed value 32-bit			x
102	Speed setpoint, 32-bit with 1 position encoder and torque reduction			x
103	Speed setpoint, 32-bit with 2 position encoders and torque reduction			x
105	Speed setpoint, 32-bit with 1 position encoder, torque reduction and DSC			x
106	Speed setpoint, 32-bit with 2 position encoders, torque reduction and DSC			x
110	Basic positioner with MDI, override and XIST_A		x	
111	Basic positioner in MDI mode		x	
116	Speed setpoint, 32-bit with 2 position encoders (encoder 1 and encoder 2), torque reduction and DSC, plus load, torque, power and current actual values			x
118	Speed setpoint, 32-bit with 2 external position encoders (encoder 2 and encoder 3), torque reduction and DSC, plus load, torque, power and current actual values			x
125	DSC with torque reduction, 1 position encoder (encoder 1)			x
126	DSC with torque precontrol, 2 position encoders (encoder 1 and encoder 2)			x

Telegram (p0922 = x)	Description	Class 1	Class 3	Class 4
136	DSC with torque precontrol, 2 position encoders (encoder 1 and encoder 2), 4 trace signals			x
138	DSC with torque precontrol, 2 external position encoders (encoder 2 and encoder 3), 4 trace signals			x
139	Speed/position control with DSC and torque precontrol, 1 position encoder, clamping status, supplementary actual values			x
166	Manufacturer-specific telegram for hydraulic axis (HLA) with 2 encoder channels and HLA additional signals	x	x	x
220	Speed setpoint, 32-bit for metal industry	x		
352	Speed setpoint, 16-bit, PCS7	x		
370	Infeed	x	x	x
371	Infeed, metal industry	x		
390	Control Unit with digital inputs/outputs	x	x	x
391	Control Unit with digital inputs/outputs and 2 measuring probes	x	x	x
392	Control Unit with digital inputs/outputs and 6 measuring probes	x	x	x
393	Control Unit with digital inputs/outputs, 8 probes and analog input	x	x	x
394	Control Unit with digital inputs/outputs	x	x	x
395	Control Unit with digital inputs/outputs and 16 probes	x	x	x
396	Telegram for the transfer of DU-global status data (DO CU), for the control of the digital I/O on SOC-CUs, as well as for 8 CU probe channels and 8 CU cam controllers	x	x	x
999	Free telegrams	x	x	x

Dynamic Servo Control (DSC)

The PROFIdrive profile contains the "Dynamic Servo Control" control concept. This requires application class 4 and transfers not only the speed setpoint, but also the KPC position controller gain factor and the XERR system deviation. With the aid of this data, the position controller can be calculated in the drive. The position setpoint interpolation is still performed in the controller. This can be used to significantly increase the dynamic stability of the position control loop in application class 4.

11.1 Communication according to PROFIdrive

11.1.2 Cyclic communication

Cyclic communication is used to exchange time-critical process data (e.g. setpoints and actual values).

11.1.2.1 Telegrams and process data

The process data (PZD) that is to be transferred is defined through the configuration of the drive unit (Control Unit). You can view and change the telegrams to be transferred in the STARTER screen form:

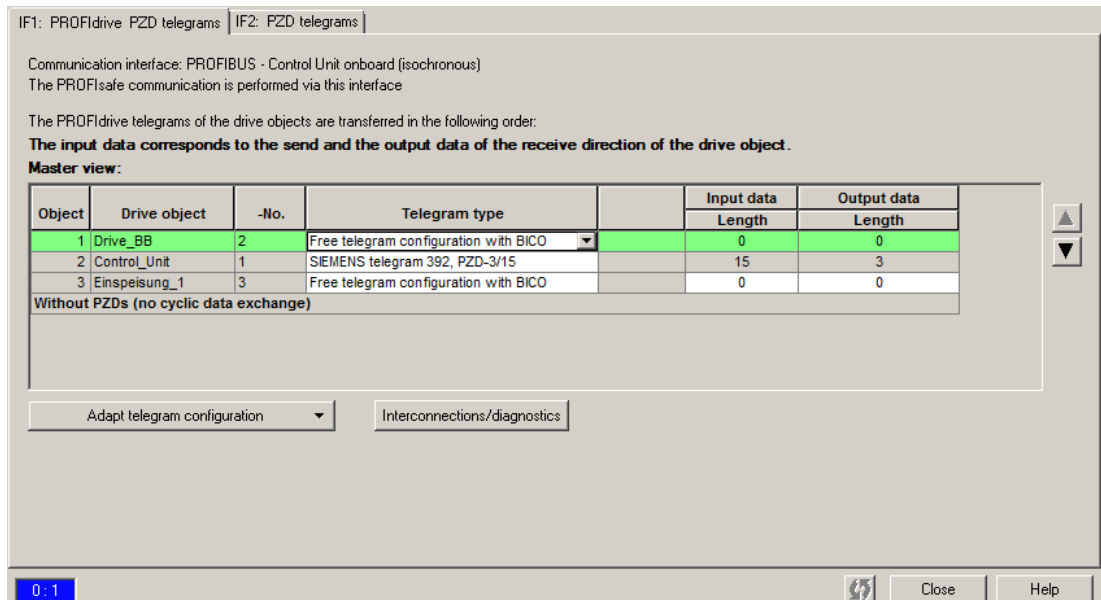

Figure 11-1 PZD telegrams

From the perspective of the drive unit, the received process data represents the receive words and the process data to be sent the send words.

PROFIdrive telegrams

- Standard telegrams

The standard telegrams are structured in accordance with the PROFIdrive profile. The drive-internal process data links are set up automatically in the STARTER in accordance with the telegram number setting.

The SINAMICS S120/S150 List Manual contains the standard telegrams in the following function diagrams:

- 2415 PROFIdrive - Standard telegrams and process data 1
- 2416 PROFIdrive - Standard telegrams and process data 2

- Manufacturer-specific telegrams

The manufacturer-specific telegrams are structured in accordance with internal company specifications. The drive-internal process data links are set up automatically in the STARTER in accordance with the telegram number setting.

The SINAMICS S120/S150 List Manual contains the manufacturer-specific telegrams (SIEMENS telegrams) in the following function diagrams:

- 2419 PROFIdrive - Manufacturer-specific telegrams and process data 1
- 2420 PROFIdrive - Manufacturer-specific telegrams and process data 2
- 2421 PROFIdrive - Manufacturer-specific telegrams and process data 3
- 2422 PROFIdrive - Manufacturer-specific telegrams and process data 4

- Free telegrams (p0922 = 999)

The SINAMICS S120/S150 List Manual contains the parameterized free telegrams in the following function diagrams:

- 2423 PROFIdrive - Manufacturer-specific/free telegrams and process data

The receive and send data can be freely connected using BICO technology.

	SERVO, TM41	VECTOR	CU_S	A_INF, B_INF, S_INF	TB30, TM31, TM15DI_DO, TM120, TM150	ENCODER
Receive process data						
DWORD connector output	r2060[0 ... 18]	r2060[0 ... 30]	-	-	-	r2060[0 ... 2]
WORD connector output	r2050[0 ... 19]	r2050[0 ... 31]	r2050[0 ... 19]	r2050[0 ... 9]	r2050[0 ... 4]	r2050[0 ... 3]
Binector output	r2090.0 ... 15 r2091.0 ... 15 r2092.0 ... 15 r2093.0 ... 15			r2090.0 ... 15 r2091.0 ... 15		r2090.0 ... 15 r2091.0 ... 15 r2092.0 ... 15 r2093.0 ... 15
Free binector-connector converter	p2080[0 ... 15], p2081[0 ... 15], p2082[0 ... 15], p2083[0 ... 15], p2084[0...15] / r2089[0 ... 4]					
Send process data						
DWORD connector input	p2061[0 ... 26]	p2061[0 ... 30]	-	-	-	p2061[0 ... 10]
WORD connector input	p2051[0 ... 27]	p2051[0 ... 31]	p2051[0 ... 24]	p2051[0 ... 9]	p2051[0 ... 4]	p2051[0 ... 11]
Free connector-binector converter	p2099[0 ... 1] / r2094.0 ... 15, r2095.0 ... 15					

Telegram interconnections

- The telegram interconnection is made automatically and blocked.
Telegrams 20, 111, 220, 352 are exceptions. There, in addition to the fixed interconnections, selected process data (PZD) can be interconnected as required in the send/receive telegram.
- When you change p0922 ≠ 999 to p0922 = 999, the previous telegram interconnection is retained and can now be changed.
- If p0922 = 999, a telegram can be selected in p2079. A telegram interconnection is automatically made and blocked. The telegram can also be extended.
This is an easy method for creating extended telegram interconnections on the basis of existing telegrams.

The telegram structure

- Parameter p0978 contains the drive objects that use a cyclic PZD exchange. All drive objects after the first zero do not participate in the cyclic exchange.
- If the value 255 is written to p0978, this drive unit is visible to the PROFIBUS master and empty (without the actual process data exchange). This enables cyclic communication of a PROFIBUS master in the following cases:
 - with unchanged configuration to drive units that have a different number of drive objects.
 - with deactivated drive objects, without having to change the project
- One PZD = one word.
- Physical word and double word values are inserted in the telegram as referenced variables.
- p200x apply as reference variables (telegram contents = 4000 hex or 4000 0000 hex in the case of double words if the input variable has the value p200x).

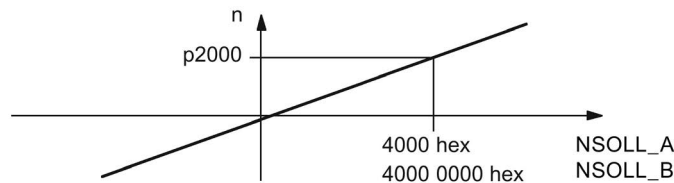

Figure 11-2 Normalization of speed

You can find the detailed structure of the telegrams in the SINAMICS S120/S150 List Manual in the associated function diagrams.

Which drive objects support which telegrams?

Drive object	Telegrams (p0922)	Function diagrams
A_INF	370, 371, 999	2421, 2423
B_INF	370, 371, 999	2421, 2423
S_INF	370, 371, 999	2421, 2423
SERVO	1, 2, 3, 4, 5, 6, 102, 103, 105, 106, 116, 118, 125, 126, 136, 138, 139, 166, 220, 999	2415, 2419, 2420
SERVO (EPOS)	7, 9, 110, 111, 999	2415, 2423
SERVO (position control)	139, 999	2420
VECTOR	1, 2, 20, 166, 220, 352, 999	2415, 2416, 2421
VECTOR (EPOS)	7, 9, 110, 111, 999	2415, 2419, 2423
ENC	81, 82, 83, 999	2416, 2423
TM15DI_DO	No predefined telegram.	-
TM31	No predefined telegram.	-
TM41	3, 999	2415, 2423
TM120	No predefined telegram.	-
TM150	No predefined telegram.	-
TB30	No predefined telegram.	-
CU_S	390, 391, 392, 393, 394, 395, 396, 999	2422, 2423

Depending on the drive object, different process data (PZD) can be sent and received:

Drive objects	Maximum number of PZD	
	Send	Receive
A_INF	10	10
B_INF	10	10
S_INF	10	10
SERVO	28	20
VECTOR	32	32
ENC	12	4
TM15DI_DO	5	5
TM31	5	5
TM41	28	20
TM120	5	5
TM150	5	5
TB30	5	5
CU	25	20

Interface Mode

Interface Mode is used for adjusting the assignment of the control and status words in line with other drive systems and standardized interfaces.

The Interface Mode can be set as follows:

Value	Interface Mode
p2038 = 0	SINAMICS (factory setting)
p2038 = 1	SIMODRIVE 611 universal
p2038 = 2	VIK-NAMUR

Procedure:

1. Set p0922 ≠ 999.
2. p2038 = set required interface mode.

When positioning telegrams 7, 9, 110, and 111 are set, the "SINAMICS" Interface Mode is permanently specified (p2038 = 0). This relationship cannot be changed.

When telegrams 102, 103, 105, 106, 116, 118, 125, 126, 136, 138 and 139 are set, the "SIMODRIVE 611 universal" Interface Mode is permanently specified (p2038 = 1). This relationship cannot be changed.

When standard telegram 20 is set, the "VIK-NAMUR" Interface Mode is permanently specified (p2038 = 2). This relationship cannot be changed.

When a telegram that permanently specifies the Interface Mode (e.g. p0922 = 102) is changed to a different telegram (e.g. p0922 = 3) that does not specify the Interface Mode, the original setting in p2038 is retained.

11.1.2.2 Information about control words and status words

Overview of control words and setpoints

A detailed overview of the control words and setpoints is contained in the SINAMICS S120/S150 List Manual in the following function diagrams:

- 2439 PROFIdrive - PZD receive signals, profile-specific interconnection
- 2440 PROFIdrive - PZD receive signals, manufacturer-specific interconnection

Overview of status words and actual values

A detailed overview of the status words and actual values is contained in the SINAMICS S120/S150 List Manual in the following function diagrams:

- 2449 PROFIdrive - PZD send signals, profile-specific interconnection
- 2450 PROFIdrive - PZD send signals, manufacturer-specific interconnection

11.1.2.3 Examples

Based on the PROFIdrive communication of the encoder interface, the following application examples show:

- The chronological sequence of the communication
- The chronological changes to the control and status words
- The mutual dependencies of these changes

Example: Encoder interface

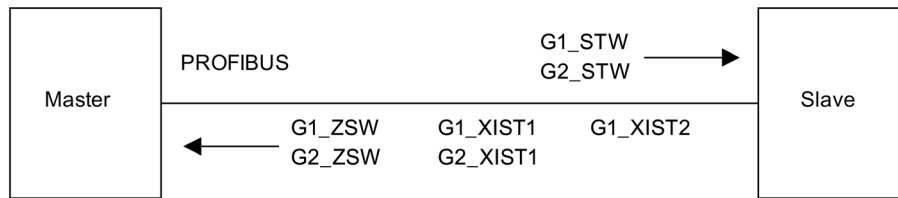

Figure 11-3 Example of encoder interface (encoder 1: Two actual values, encoder 2: One actual value)

Example: Find reference mark

Assumptions for the example:

- Distance-coded reference mark
- Two reference marks (function 1 / function 2)
- Position control with encoder 1

Figure 11-4 Sequence chart for "Find reference mark"

Example: Flying measurement

Assumptions for the example:

- Measuring probe with rising edge (function 1)
- Position control with encoder 1

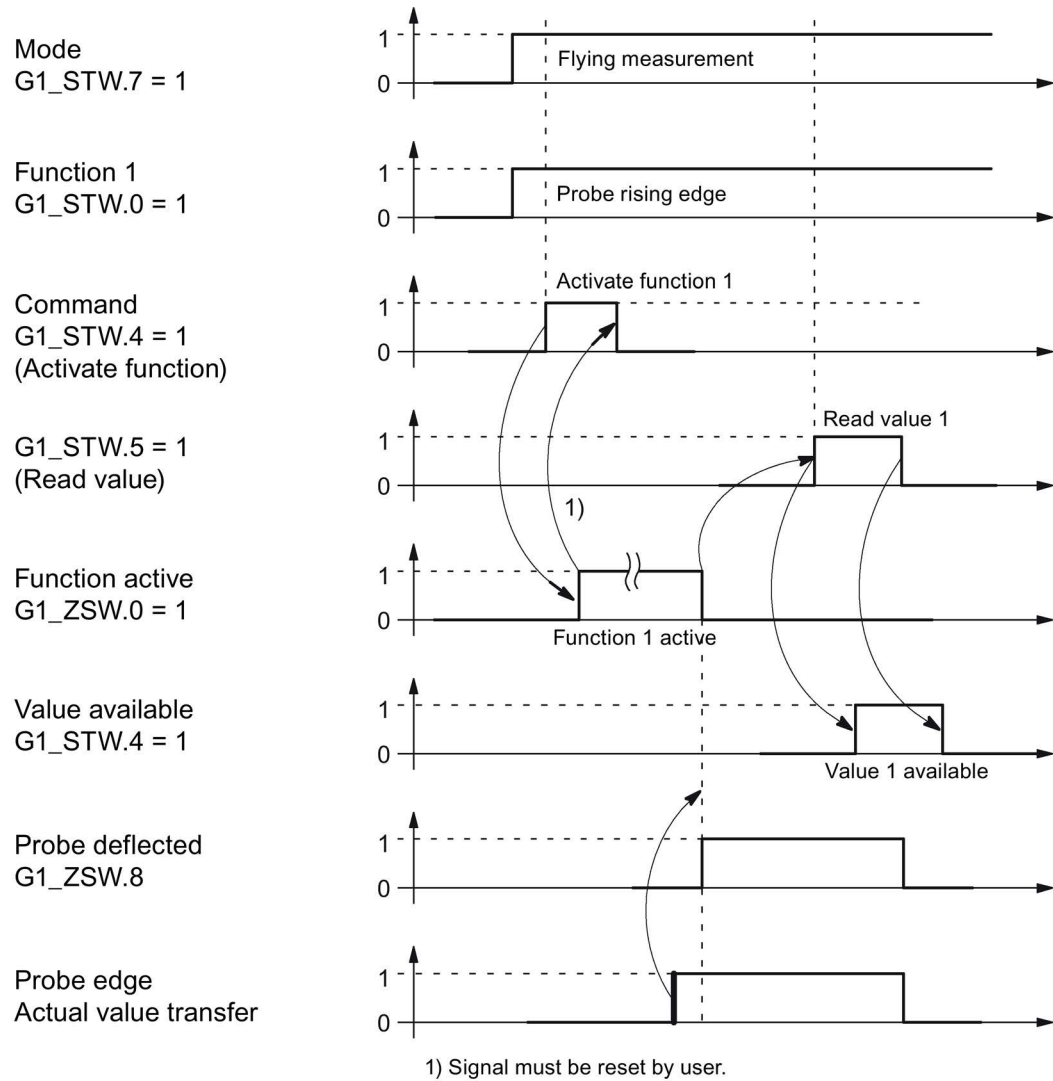

Figure 11-5 Sequence chart for "Flying measurement"

11.1.2.4 Motion control with PROFIdrive

The "Motion Control with PROFIBUS" or "Motion Control with PROFINET" function can be used to implement an isochronous drive coupling between a master (a controller) and one or more slaves (drives) via PROFIBUS or an isochronous drive coupling via PROFINET.

Note

The isochronous drive coupling is defined in the following documentation:

PROFIdrive Profile Drive Technology

PROFIBUS User Organization e. V.
Haid-und-Neu-Straße 7, D-76131 Karlsruhe,
Internet: (<http://www.profibus.com>)

Properties

- No additional parameters need to be entered in addition to the bus configuration in order to activate this function, the master and slave must only be preset for this function (PROFIBUS).
- The master-side default setting is made via the hardware configuration, e.g. HW Config with SIMATIC S7. The slave-side default setting is made via the parameterization telegram when the bus is ramping up.
- Fixed sampling times are used for all data communication.
- The Global Control (GC) clock information on PROFIBUS is sent before the beginning of each cycle.
- The cycle length depends on the bus configuration. When the cycle is selected, the bus configuration tool (e.g. HW Config) supports:
 - Large number of drives per slave / drive unit → longer cycle
 - Large number of slaves / drive units → longer cycle
- A sign-of-life counter is used to monitor user data transfer and clock pulse failures.

Overview of closed-loop control

- Sensing of the actual position value on the slave can be performed using:
 - Indirect measuring system (motor encoder)
 - Additional direct measuring system
- The encoder interface must be configured in the process data.
- The control loop is closed via PROFIBUS.
- The position controller is located on the master.
- The current and speed control systems and actual value sensing (encoder interface) are located on the slave.
- The position controller cycle is transferred via the fieldbus to the slaves.
- The slaves synchronize their speed and/or current controller cycle with the position controller cycle on the master.
- The speed setpoint is specified by the master.

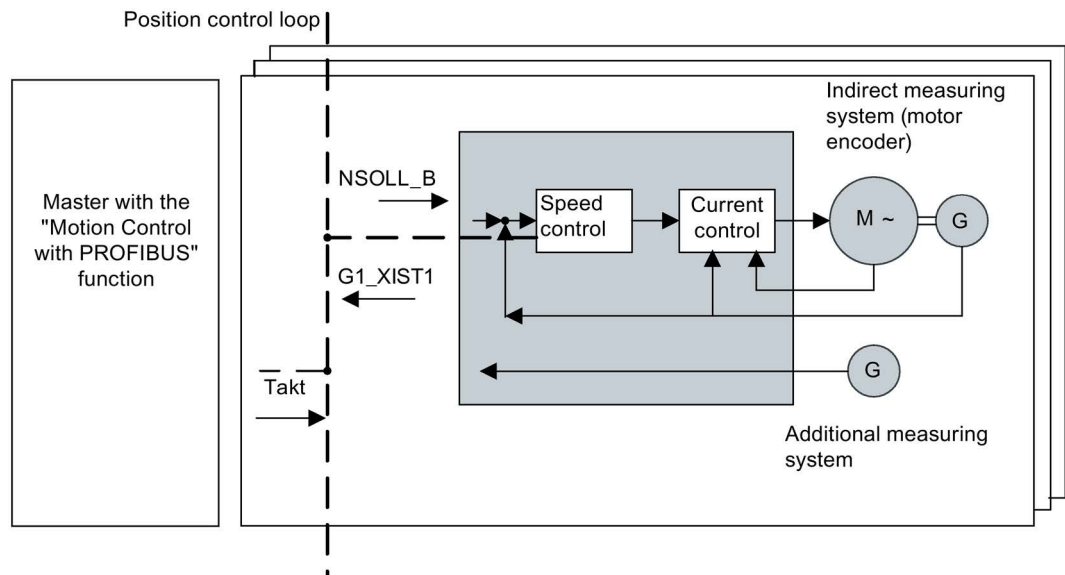

Figure 11-6 Overview of "Motion Control with PROFIBUS" (example: Master and three slaves)

Structure of the data cycle

The data cycle comprises the following elements:

- Global control telegram (PROFIBUS only)
- Cyclic part - setpoints and actual values
- Acyclic part - parameters and diagnostic data
- Reserve (PROFIBUS only)
 - Token passing (Token Holding Time, TTH)
 - For searching for a new node in the drive line-up (GAP)
 - Waiting time until start of the next cycle

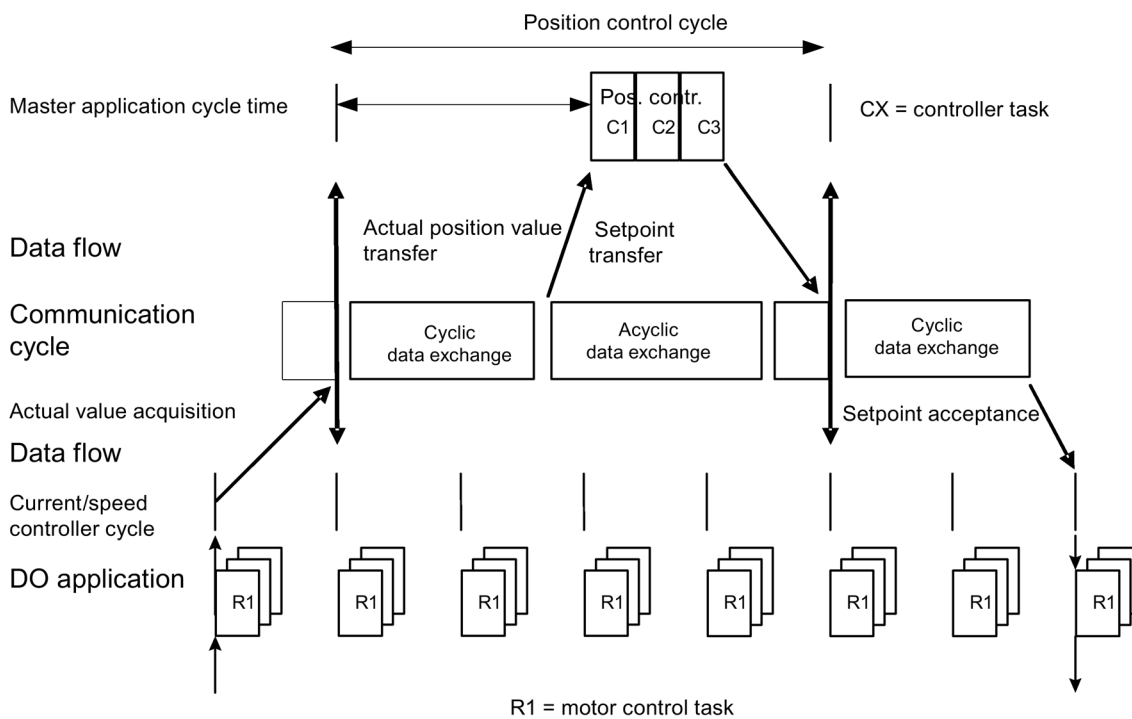

Figure 11-7 Isochronous drive coupling / motion control with PROFIdrive

11.1.3 Parallel operation of communication interfaces

The two cyclic interfaces for the setpoints and actual values differ by the parameter ranges used (BICO technology etc.) and the functions that can be used. The interfaces are designated as cyclic interface 1 (IF1) and cyclic interface 2 (IF2).

Cyclic process data (setpoints / actual values) are processed using interfaces IF1 and IF2. The following interfaces are used:

- Onboard interfaces of the Control Unit for PROFIBUS DP or PROFINET.
- An optional interface (COMM BOARD) for PROFINET (CBE20) or CANopen (CBC10) for insertion in the Control Unit.

Parameter p8839 is used to set the parallel use of the Control Unit onboard interfaces and COMM - BOARD in the SINAMICS system. The functionality is assigned to interfaces IF1 and IF2 using indices.

For example, the following applications are possible:

- PROFIBUS DP for control and PROFINET to acquire actual values / measured values of the drive
- PROFIBUS DP for control and PROFINET for engineering only
- Mixed mode with two masters (the first for logic and coordination and the second for technology)
- SINAMICS Link via IF2 (CBE20); standard telegrams and PROFIsafe via IF1
- Operation of redundant communication interfaces

Assignment of communication interfaces to cyclic interfaces

With the factory setting p8839 = 99, the communication interfaces are permanently assigned one of the cyclic interfaces (IF1, IF2), depending on the communication system, e.g. PROFIBUS DP, PROFINET or CANopen.

The assignment to the cyclic interfaces can essentially be freely defined by user parameterization for the parallel operation of the communication interfaces.

Properties of the cyclic interfaces IF1 and IF2

Table 11- 5 Properties of the cyclic interfaces IF1 and IF2

Feature	IF1	IF2
Setpoint (BICO signal source)	r2050, r2060	r8850, r8860
Actual value (BICO signal sink)	p2051, p2061	p8851, p8861

Table 11- 6 Implicit assignment of hardware to the cyclic interfaces for p8839[0] = p8839[1] = 99

Plugged hardware interface	IF1	IF2
No option, only use Control Unit onboard interface (PROFIBUS, PROFINET or USS)	Control Unit onboard	--
CU320-2 DP with CBE20 (optional PROFINET interface)	COMM BOARD	Control Unit onboard PROFIBUS or Control Unit onboard USS
CU320-2 PN with CBE20 (optional PROFINET interface)	Control Unit onboard	COMM BOARD PROFINET
CAN option CBC10	Control Unit onboard	COMM BOARD CAN

Parameter p8839[0,1] is used to set the parallel operation of the hardware interfaces and the assignment to the cyclic interfaces IF1 and IF2 for the Control Unit drive object.

The object sequence for process data exchange via IF2 depends on the object sequence from IF1; see "List of drive objects" (p0978).

The factory setting of p8839[0,1] = 99 enables the implicit assignment (see table above).

An alarm is generated in case of invalid or inconsistent parameterization of the assignment.

Note

Parallel operation of PROFIBUS and PROFINET

The data of isochronous applications can only be processed via one of the two interfaces IF1 or IF2 (p8815). Two parameterization options are possible if additionally the PROFINET module CBE20 is inserted in the CU320-2 DP:

- p8839[0] = 1 and p8839[1] = 2: PROFIBUS isochronous, PROFINET cyclic
- p8839[0] = 2 and p8839[1] = 1: PROFINET isochronous, PROFIBUS cyclic

Parameters for IF2

The following parameters are available in order to tune the IF2 for a PROFIBUS or PROFINET interface:

- Receive and send process data:
r8850, p8851, r8853, r8860, p8861, r8863¹⁾
- Diagnostic parameters:
r8874, r8875, r8876¹⁾
- Binector-connector converters:
p8880, p8881, p8882, p8883, p8884, r8889¹⁾
- Connector-binector converters:
r8894, r8895, p8898, p8899¹⁾

¹⁾ Significance of 88xx identical to 20xx

Note

Using the HW Config configuration tool, a PROFIBUS slave / PROFINET device with two interfaces cannot be shown. In parallel operation, this is the reason that SINAMICS drive appears twice in the project or in two projects, although physically it is just one device.

Parameter

p8839	PZD Interface hardware assignment
Description:	Assigning the hardware for cyclic communication via PZD interface 1 and interface 2.
Values:	0: Inactive
	1: Control Unit onboard
	2: COMM BOARD
	99: Automatic

For p8839, the following rules apply:

- The setting of p8839 applies for all drive objects of a Control Unit (device parameter).
- For the setting p8839[0] = 99 and p8839[1] = 99 (automatic assignment, factory setting), the hardware used is automatically assigned to interfaces IF1 and IF2. Both indices must be selected so that the automatic assignment is activated. If both indices are not selected, then an alarm is output and the setting p8839[x] = 99 is treated just like 'inactive'.
- An alarm is issued if the same hardware (Control Unit onboard or COMM BOARD) is selected in p8839[0] and p8839[1]. The following then applies: The setting of p8839[0] is valid, and the setting of p8839[1] is treated like 'inactive'.
- If the CAN board (CBC10) is used, the entry of p8839[0] = 2 is not permissible (no assignment of the CAN board to IF1). An alarm is then issued.
- If p8839[x] is set to 2, and the COMM BOARD is missing or defective, then the corresponding interface is not supplied from the Control Unit onboard interface. Message A08550 is output instead.

Overview of important parameters (see SINAMICS S120/S150 List Manual)

- p0922 IF1 PROFIdrive PZD telegram selection
- p0978[0...n] List of drive objects
- p8815[0...1] IF1/IF2 PZD functionality selection
- p8839[0...1] PZD interface hardware assignment

11.1.4 Acyclic communication

11.1.4.1 General information about acyclic communication

With acyclic communication, as opposed to cyclic communication, data transfer takes place only when an explicit request is made (e.g. in order to read and write parameters).

The "Read data record" and "Write data record" services are available for acyclic communication.

The following options are available for reading and writing parameters:

- S7 protocol

This protocol uses the STARTER commissioning tool, for example, in the online mode via PROFIBUS.

- PROFIdrive parameter channel with the following data sets:

- PROFIBUS: Data block 47 (0x002F)

The DPV1 services are available for master class 1 and class 2.

- PROFINET: Data block 47 and 0xB02F at global access, data set 0xB02E as local access

Note

Refer to the following documentation for a detailed description of acyclic communication:

Reference: PROFIdrive Profile V4.1, May 2006, Order No.: 3.172

Addressing:

- PROFIBUS DP

The addressing is carried out via the logical address or the diagnostics address.

- PROFINET IO

The addressing is only undertaken using a diagnostics address which is assigned to a module as of slot 1. Parameters cannot be accessed via socket 0.

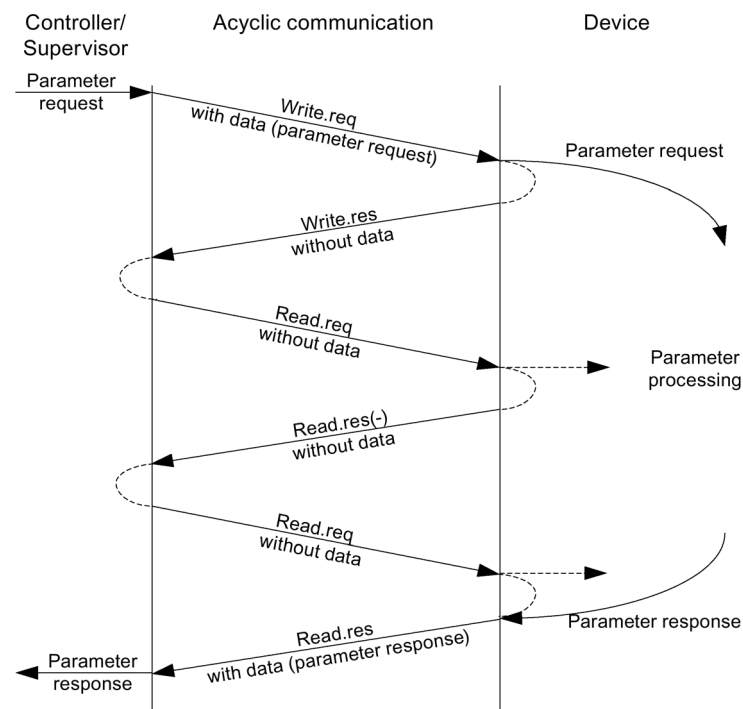

Figure 11-8 Reading and writing data

Characteristics of the parameter channel

- One 16-bit address exists for each parameter number and subindex.
- Concurrent access by several additional PROFIBUS masters (master class 2) or PROFINET IO supervisor (e.g. commissioning tool).
- Transfer of different parameters in one access (multiple parameter request).
- Transfer of complete arrays or part of an array possible.
- Only one parameter request is processed at a time (no pipelining).
- A parameter request/response must fit into a data set (e.g. PROFIBUS: Max. 240 bytes).
- The request or the response header is user data.

11.1.4.2 Structure of requests and responses

Structure of parameter request and parameter response

	Parameter request			Offset
Values for write access only	Request header	Request reference	Request ID	0
		Axis	Number of parameters	2
	1st parameter address	Attribute	Number of elements	4
		Parameter number		6
		Subindex		8
	...			
	nth parameter address	Attribute	Number of elements	
		Parameter number		
		Subindex		
	1st parameter value(s)	Format	Number of values	
		Values		
		...		
	...			
	nth parameter value(s)	Format	Number of values	
Values				
...				

	Parameter response			Offset
Values for read access only Error values for negative response only	Response header	Request reference mirrored	Response ID	0
		Axis mirrored	Number of parameters	2
	1st parameter value(s)	Format	Number of values	4
		Values or error values		6
		...		
	...			
	nth parameter value(s)	Format	Number of values	
		Values or error values		
		...		

Description of fields in the parameter request and response

Field	Data type	Values	Remark
Request reference	Unsigned8	0x01 ... 0xFF	
	Unique identification of the request/response pair for the master. The master changes the request reference with each new request. The slave mirrors the request reference in its response.		
Request ID	Unsigned8	0x01 0x02	Read request Write request
	Specifies the type of request. In the case of a write request, the changes are made in a volatile memory (RAM). A save operation is needed in order to transfer the modified data to the non-volatile memory (p0971, p0977).		
Response ID	Unsigned8	0x01 0x02 0x81 0x82	Read request (+) Write request (+) Read request (-) Write request (-)
	Mirrors the request identifier and specifies whether request execution was positive or negative. Negative means: Cannot execute part or all of request. The error values are transferred instead of the values for each subresponse.		
Drive object number	Unsigned8	0x00 ... 0xFF	Number
	Specification of the drive object number for a drive unit with more than one drive object. Different drive objects with separate parameter number ranges can be accessed over the same DPV1 connection.		
Number of parameters	Unsigned8	0x01 ... 0x27	No. 1 ... 39 Limited by DPV1 telegram length
	Defines the number of adjoining areas for the parameter address and/or parameter value for multi-parameter requests. The number of parameters = 1 for single requests.		
Attribute	Unsigned8	0x10 0x20 0x30	Value Description Text (not implemented)
	Type of parameter element accessed.		
Number of elements	Unsigned8	0x00 0x01 ... 0x75	Special function No. 1 ... 117 Limited by DPV1 telegram length
	Number of array elements accessed.		
Parameter number	Unsigned16	0x0001 ... 0xFFFF	No. 1 ... 65535
	Addresses the parameter to be accessed.		
Subindex	Unsigned16	0x0000 ... 0xFFFF	No. 0 ... 65535
	Addresses the first array element of the parameter to be accessed.		

11.1 Communication according to PROFIdrive

Field	Data type	Values	Remark
Format	Unsigned8	0x02	Data type integer8
		0x03	Data type integer16
		0x04	Data type integer32
		0x05	Data type unsigned8
		0x06	Data type unsigned16
		0x07	Data type unsigned32
		0x08	Data type floating point
		Other values	See PROFIdrive profile V3.1
		0x40	Zero (without values as a positive subresponse to a write request)
		0x41	Byte
		0x42	Word
		0x43	Double word
		0x44	Error
The format and number specify the adjoining space containing values in the telegram. For write access, it is preferable to specify data types according to the PROFIdrive profile. Bytes, words and double words are also possible as a substitute.			
Number of values	Unsigned8	0x00 ... 0xEA	No. 0 ... 234
			Limited by DPV1 telegram length
Specifies the number of subsequent values.			
Error values	Unsigned16	0x0000 ... 0x00FF	Significance of the error values → refer to the following table "Error values in the DPV1 parameter responses"
			The error values in the event of a negative response. If the values make up an odd number of bytes, a zero byte is attached. This ensures the integrity of the word structure of the telegram.
Values	Unsigned16	0x0000 ... 0x00FF	
			The values of the parameter for read or write access. If the number of bytes is odd, a zero byte is appended. This ensures the integrity of the word structure of the telegram.

Error values in parameter responses

Error value	Meaning	Remark	Additional info
0x00	Illegal parameter number.	Access to a parameter that does not exist.	–
0x01	Parameter value cannot be changed.	Modification access to a parameter value that cannot be changed.	Subindex
0x02	Lower or upper value limit exceeded.	Modification access with value outside value limits.	Subindex
0x03	Invalid subindex.	Access to a subindex that does not exist.	Subindex
0x04	No array.	Access with subindex to an unindexed parameter.	–
0x05	Wrong data type.	Modification access with a value that does not match the data type of the parameter.	–
0x06	Illegal set operation (only reset allowed).	Modification access with a value not equal to 0 in a case where this is not allowed.	Subindex
0x07	Description element cannot be changed.	Modification access to a description element that cannot be changed.	Subindex
0x09	No description data available.	Access to a description that does not exist (the parameter value exists).	–
0x10	Read job will not be executed.	The read request is refused because know-how protection is active.	
0x0B	No operating priority.	Modification access with no operating priority.	–
0x0F	No text array exists.	Access to a text array that does not exist (the parameter value exists).	–
0x11	Request cannot be executed due to operating status.	Access is temporarily not possible for unspecified reasons.	–
0x14	Illegal value.	Modification access with a value that is within the limits but is illegal for other permanent reasons (parameter with defined individual values).	Subindex
0x15	Response too long.	The length of the present response exceeds the maximum transfer length.	–
0x16	Illegal parameter address.	Illegal or unsupported value for attribute, number of elements, parameter number, subindex or a combination of these.	–
0x17	Illegal format.	Write request: Illegal or unsupported parameter data format.	–
0x18	Number of values inconsistent.	Write request: A mismatch exists between the number of values in the parameter data and the number of elements in the parameter address.	–
0x19	Drive object does not exist.	You have attempted to access a drive object that does not exist.	–
0x20	Parameter text cannot be changed	–	–
0x21	Service not supported.	Illegal or unknown request ID	–
0x65	Parameter presently deactivated.	You have tried to access a parameter that, although available, does not currently perform a function (e.g. n control set and access to a V/f control parameter).	–
0x6B	Write access for the enabled controller.	Write access is possible while the device is in the "Controller enable" state. Pay attention to the parameter attribute "changeable" in the SINAMICS S120/S150 List Manual (C1, C2, U, T).	–

11.1 Communication according to PROFdrive

Error value	Meaning	Remark	Additional info
0x6C	Parameter %s [%s]: Unknown unit.	–	–
0x6D	Parameter %s [%s]: Write access only in the commissioning state, encoder (p0010 = 4).	–	–
0x6E	Parameter %s [%s]: Write access only in the commissioning state, motor (p0010 = 3).	–	–
0x6F	Parameter %s [%s]: Write access only in the commissioning state, power unit (p0010 = 2).	–	–
0x70	Parameter %s [%s]: Write access only in the quick commissioning mode (p0010 = 1).	–	–
0x71	Parameter %s [%s]: Write access only in the ready mode (p0010 = 0).	–	–
0x72	Parameter %s [%s]: Write access only in the commissioning state, parameter reset (p0010 = 30).	–	–
0x73	Parameter %s [%s]: Write access only in the commissioning state, Safety (p0010 = 95).	–	–
0x74	Parameter %s [%s]: Write access only in the commissioning state, tech. application/units (p0010 = 5).	–	–
0x75	Parameter %s [%s]: Write access only in the commissioning state (p0010 not equal to 0).	–	–
0x76	Parameter %s [%s]: Write access only in the commissioning state, download (p0010 = 29).	–	–
0x77	Parameter %s [%s] must not be written during download.	–	–
0x78	Parameter %s [%s]: Write access only in the commissioning state, drive configuration (device: p0009 = 3).	–	–
0x79	Parameter %s [%s]: Write access only in the commissioning state, define drive type (device: p0009 = 2).	–	–
0x7A	Parameter %s [%s]: Write access only in the commissioning state, data record base configuration (device: p0009 = 4).	–	–
0x7B	Parameter %s [%s]: Write access only in the commissioning state, device configuration (device: p0009 = 1).	–	–

Error value	Meaning	Remark	Additional info
0x7C	Parameter %s [%s]: Write access only in the commissioning state, device download (device: p0009 = 29).	–	–
0x7D	Parameter %s [%s]: Write access only in the commissioning state, device parameter reset (device: p0009 = 30).	–	–
0x7E	Parameter %s [%s]: Write access only in the commissioning state, device ready (device: p0009 = 0).	–	–
0x7F	Parameter %s [%s]: Write access only in the commissioning state, device (device: p0009 not equal to 0).	–	–
0x81	Parameter %s [%s] must not be written during download.	–	–
0x82	Transfer of master control is blocked by BI: p0806.	–	–
0x83	Parameter %s [%s]: Requested BICO interconnection not possible.	BICO output does not supply float values. The BICO input, however, requires a float value.	–
0x84	Parameter %s [%s]: Parameter change inhibited (refer to p0300, p0400, p0922)	–	–
0x85	Parameter %s [%s]: Access method not defined.	–	–
0x87	Write job will not be executed.	The write request is rejected because know-how protection is active.	–
0xC8	Below currently valid limit.	Modification request for a value that, although within "absolute" limits, is below the currently valid lower limit.	–
0xC9	Above currently valid limit.	Modification request for a value that, although within "absolute" limits, is above the currently valid lower limit (e.g. governed by the current converter rating).	–
0xCC	Write access not permitted.	Write access is not permitted because an access code is not available.	–

11.1.4.3 Determining the drive object numbers

Further information about the drive system (e.g. drive object numbers) can be determined as follows using parameters p0101, r0102, and p0107/r0107:

1. The value of parameter r0102 ("Number of drive objects") for drive object/axis 1 is read via a read request.

Drive object 1 is the Control Unit (CU) which is a minimum requirement for each drive system.

2. Depending on the result of the initial read request, further read requests for drive object 1 are used to read the indices for parameter p0101 "Drive object numbers", as specified by parameter r0102.

Example:

If the number of drive objects is "5", the values of indices 0 to 4 of parameter p0101 are read. Of course, the relevant indexes can also be read at once.

3. Following this, parameter r0107/p0107 ("Drive object type") is read for each drive object/axis (indicated by the drive object number).

Depending on the drive object, parameter 107 can be either an adjustable parameter or a display parameter.

The value in parameter r0107/p0107 indicates the drive object type. The coding for the drive object type is specified in the parameter list.

11.1.4.4 Example 1: read parameters

Requirements

- The PROFIdrive controller has been commissioned and is fully operational.
- PROFIdrive communication between the controller and the device is operational.
- The controller can read and write data sets in conformance with PROFINET/PROFIBUS.

Task description

Following the occurrence of at least one fault (ZSW1.3 = "1") on drive 2 (also drive object number 2), the active fault codes must be read from the fault buffer r0945[0] ... r0945[7].

The request is to be handled using a request and response data block.

Basic procedure

1. Create a request to read the parameters.
2. Invoke the request.
3. Evaluate the response.

Create the request

Parameter request			Offset
Request header	Request reference = 25 hex	Request ID = 01 hex	0 + 1
	Axis = 02 hex	Number of parameters = 01 hex	2 + 3
Parameter address	Attribute = 10 hex	Number of elements = 08 hex	4 + 5
	Parameter no. = 945 dec		6
	Subindex = 0 dec		8

Information about the parameter request:

- Request reference:

The value is selected at random from the valid value range. The request reference establishes the relationship between request and response.
- Request ID:

01 hex → This identifier is required for a read request.
- Axis:

02 hex → Drive 2, fault buffer with drive- and device-specific faults.
- Number of parameters:

01 hex → One parameter is read.
- Attribute:

10 hex → The parameter values are read.
- Number of elements:

08 hex → The actual fault incident with eight faults is to be read.
- Parameter number:

945 dec → p0945 (fault code) is read.
- Subindex:

0 dec → Reading starts at index 0.

Initiate parameter request.

If ZSW1.3 = "1" → Initiate parameter request

Evaluate the parameter response.

Parameter response			Offset
Response header	Request reference mirrored = 25 hex	Response ID = 01 hex	0 + 1
	Axis mirrored = 02 hex	Number of parameters = 01 hex	2 + 3
Parameter value	Format = 06 hex	Number of values = 08 hex	4 + 5
	1st value = 1355 dec		6
	2nd value = 0 dec		8

	8th value = 0 dec		20

Information about the parameter response:

- Request reference mirrored:
This response belongs to the request with request reference 25.
- Response ID:
01 hex → Read request positive, values stored as of 1st value.
- Axis mirrored, number of parameters:
The values correspond to the values from the request.
- Format:
06 hex → Parameter values are in the unsigned16 format.
- Number of values:
08 hex → Eight parameter values are available.
- 1st value ... 8th value
A fault is only entered in value 1 of the fault buffer for drive 2.

11.1.4.5 Example 2: Writing parameters (multi-parameter request)

Requirements

- The PROFIdrive controller has been commissioned and is fully operational.
- PROFIdrive communication between the controller and the device is operational.
- The controller can read and write data sets in conformance with PROFINET/PROFIBUS.
Special requirements for this example:
- Servo control or vector control with activated "Extended setpoint channel" function module

Create the request

Parameter request			Offset
Request header	Request reference = 40 hex	Request ID = 02 hex	0 + 1
	Axis = 02 hex	Number of parameters = 04 hex	2 + 3
1st parameter address	Attribute = 10 hex	Number of elements = 01 hex	4 + 5
	Parameter no. = 1055 dec		6
	Subindex = 0 dec		8
2nd parameter address	Attribute = 10 hex	Number of elements = 01 hex	10 + 11
	Parameter no. = 1056 dec		12
	Subindex = 0 dec		14
3rd parameter address	Attribute = 10 hex	Number of elements = 01 hex	16 + 17
	Parameter no. = 1058 dec		18
	Subindex = 0 dec		20
4th parameter address	Attribute = 10 hex	Number of elements = 01 hex	22 + 23
	Parameter no. = 1059 dec		24
	Subindex = 0 dec		26
1st parameter value(s)	Format = 07 hex	Number of values = 01 hex	28 + 29
	Value = 02D2 hex		30
	Value = 0404 hex		32
2nd parameter value(s)	Format = 07 hex	Number of values = 01 hex	34 + 35
	Value = 02D2 hex		36
	Value = 0405 hex		38
3rd parameter value(s)	Format = 08 hex	Number of values = 01 hex	40 + 41
	Value = 4396 hex		42
	Value = 0000 hex		44
4th parameter value(s)	Format = 08 hex	Number of values = 01 hex	46 + 47
	Value = 4416 hex		48
	Value = 0000 hex		50

Notes relating to the parameter request:

- Request reference:
The value is selected at random from the valid value range. The request reference establishes the relationship between request and response.
- Request ID:
02 hex → This identifier is required for a write request.
- Axis:
02 hex → The parameters are written to drive 2.
- Number of parameters
04 hex → The multi-parameter request comprises four individual parameter requests.

1st parameter address ... 4. Parameter address

- Attribute:
10 hex → The parameter values are to be written.
- Number of elements
01 hex → One array element is written.
- Parameter number
Specifies the number of the parameter to be written (p1055, p1056, p1058, p1059).
- Subindex:
0 dec → ID of the first array element.

1st parameter value ... 4th Parameter value

- Format:
07 hex → Data type, unsigned32
08 hex → Data type, floating point
- Number of values:
01 hex → A value is written to each parameter in the specified format.
- Value:
BICO input parameter: Enter signal source
Adjustable parameter: Enter value

Initiate parameter request.

Evaluate the parameter response.

Parameter response			Offset
Response header	Request reference mirrored = 40 hex	Response ID = 02 hex	0
	Axis mirrored = 02 hex	Number of parameters = 04 hex	2

Notes regarding the parameter response:

- Request reference mirrored:
This response belongs to the request with request reference 40.
- Response ID:
02 hex → Write request positive
- Axis mirrored:
02 hex → The value matches the value from the request.
- Number of parameters:
04 hex → The value matches the value from the request.

11.1.5 Diagnostics channels

SINAMICS drives provide the standard diagnostics for PROFIBUS and PROFINET. This allows the PROFIdrive classes of the SINAMICS drive to be integrated into the system diagnostics of a higher-level control system and automatically displayed on an HMI.

The information transferred is saved for the drive objects in the following parameters:

- r0947[0...63] fault number
- r2122[0...63] alarm code
- r9747[0...63] SI message code (with safety messages)
- r3120[0..63] component fault
- r3121[0..63] component alarm
- r9745[0..63] SI component (with safety message)

The messages entered in these parameters are combined to create PROFIdrive message classes for diagnostics. Determining the source of a message is realized by transferring the component number as channel number.

The diagnostics are activated through appropriate parameterization in the configuring tools used (e.g. using HW Config or via HWCN in the TIA Portal).

The functional scope of the diagnostic channels depends on the bus system.

		PROFIdrive message classes		
		Faults	Alarms	Component assignment
PN	GSDML	X	X	X
	TIA	X	X	X
DP	GSD	X	-	-
	TIA	X	-	-

- SINAMICS transfers the messages in the sequence in which they occurred.
- The time stamps are generated from the higher-level controller when the messages are received
- The existing mechanisms of TIA and S7 Classic can be used.
- Alarms or faults are acknowledged using the already known acknowledgment routes.
- Transfer is possible via interface IF1 and/or IF2.

Note

Constraint

If Shared device is activated, only one of the controllers can receive diagnoses.

Note

Additional information

PROFIdrive message classes of the individual SINAMICS faults and alarms are provided in the SINAMICS List Manuals.

11.1.5.1 PROFINET-based diagnostics

For PROFINET, to transfer PROFIdrive message classes, channel diagnostics (Channel Diagnosis) are used (see PROFINET IO specification (<http://www.profibus.com>)).

A message always comprises the following components in this specific sequence:

- Block Header (6 Byte)
 - Blocktype
 - Blocklength
 - BlockversionHigh
 - BlockversionLow
- API (4 Byte)
- Slot Number (2 Byte)
- Sub Slot Number (2 Byte)
- Channel Number (2 Byte)
- Channel Properties (0x8000) (2 Byte)
- User Structure Identifier (2 Byte)
- Channel Diagnosis Data (6 Byte)
 - Channel Number (2 Byte)
 - Channel Properties (2 Byte)
 - Channel Error Type (2 Byte)

Overview:

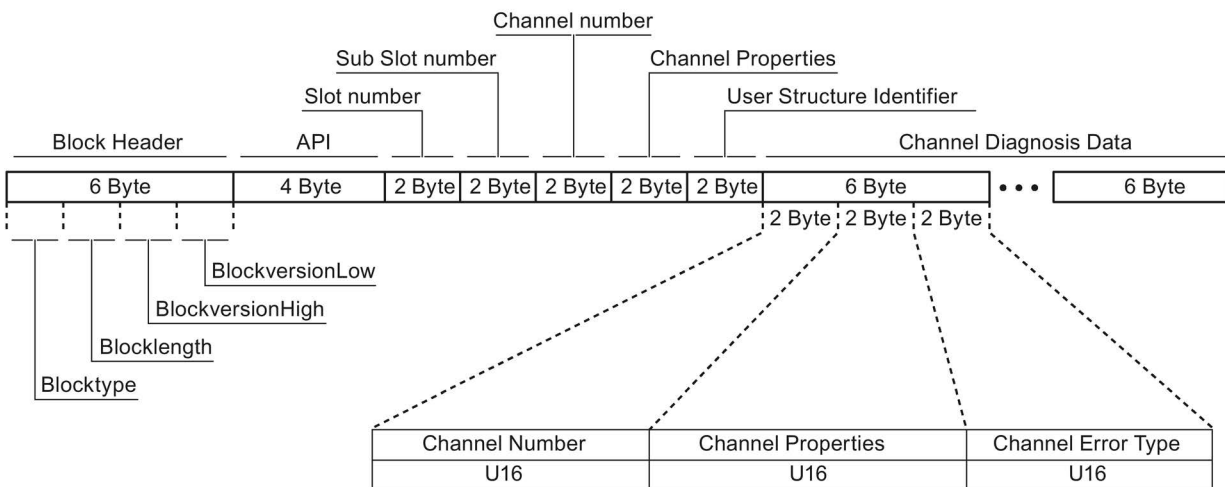

Figure 11-10 Components of a message

11.1 Communication according to PROFIdrive

Individual components of the Channel Diagnosis Data block can be included n times in a message. A precise explanation of these message components is subsequently provided:

Designation	Data type/length	For SINAMICS	
		Value	Significance
Channel Number	U16	1 ... 399 0x8000	Component number No component assignment ¹⁾
Channel Properties	U16		
.Type	Bits 7 ... 0	0	No data length
		0	1 channel; no group formation
		0	Fault → diagnostics
		1	Alarm, Class 0 or A → maintenance <i>required</i>
		2	Alarm, Class B or C → maintenance <i>demande</i>
.Specifier	Bits 12, 11	0	Not used
		1	Message received
		2	Message issued, no additional message available in the channel
		3	Message issued, additional messages are available in the channel
.Direction	Bits 15 ... 13	3	Input/Output
Channel Error Type	U16	0x9000 0x9001 0x9002 0x9003 0x9004 0x9005 0x9006 0x9007 0x9008 0x9009 0x900A 0x900B 0x900C 0x900E 0x900F 0x9010 0x9011 0x9012 0x9013	Hardware / software error Network fault Supply voltage fault DC link overvoltage Power electronics faulted Overtemperature of the electronic components Ground fault / inter-phase short circuit Motor overload Communication error to the higher-level control system Safety monitoring channel has identified an error Position/speed actual value incorrect or not available Internal (DRIVE-CLiQ) communication error Infeed faulted Line filter faulted External measured value / signal state outside the permissible range Application / technological function faulted Error in the parameterization / configuration / commissioning procedure General drive fault Auxiliary unit faulted

¹⁾ For messages, which cannot be assigned to any particular component

System response - reading out diagnostics data

The converter requests diagnostics data via "Read data set" (detailed information is provided in the PROFINET-IO specification (<http://www.profibus.com>)). Example:

For example, a read record with index 0x800C can be used to read out diagnostics data from specific sub slots. The following rules apply as example:

- 1 message block
 - if, at this drive object (one or several) faults of the same message class are identified
 - n messages
 - if, at this drive object, n faults of different message classes are identified
-

Note

If a fault is active on the CU drive object, then this fault is propagated to all of the drive objects associated with the CU. This fault can therefore be read out at each drive object.

11.1.5.2 PROFIBUS-based diagnostics

For communication via PROFIBUS, in the case of fault the following diagnostics data is output:

- Standard diagnostics (Page 738)
- Identifier-related diagnostics (Page 738)
- Status messages/module status (Page 739)
- Channel-related diagnostics (Page 740)
- Data sets DS0/DS1 and diagnostics alarm (Page 741)

Message structure

The following applies if a message contains all of the specified diagnostics data:

- Standard diagnostics
 - Is always located at the beginning of the message.
- Data sets DS0/DS1 and diagnostics alarm
 - Is always located at the end of the message. This message part is always slot-specific. The actual state of the slot responsible for the message is always transferred in the message.

The other diagnostics data (types) can be in any sequence. This is the reason that the following diagnostics data include a header:

- Identifier-related diagnostics
- Status messages/module status
- Channel-related diagnostics

The diagnostic data type can be uniquely identified based on the header.

Note

The master must operate in the DPV1 mode.

Standard diagnostics

For communication via PROFIBUS, standard diagnostics is structured as follows.

		Bit							
Octet	Name	7	6	5	4	3	2	1	0
1	Station status 1	Master_Lock = 0	Prm_Fault	0	Not_Supported	Ext_Diag	Cfg_Fault	Station_Not_Ready	Station_Non_Exist = 0
2	Station status 2	0	0	Sync_Mode	Freeze_Mode	WD_On	1	Stat_Diag = 0	Prm_Req
3	Station status 3	Ext_Diag_Overflow	0	0	0	0	0	0	0
4		Master_Add							
5		Ident_Number (HighByte) of the slave							
6		Ident_Number (LowByte) of the slave							

In this context, the following values are decisive for diagnostics:

- Ext_Diag
 - Group signal for diagnostics in the slave
 - = 1, if at least 1 alarm is active
- Ext_Diag_Overflow
 - Display, diagnostics overflow in the slave (for more than 240 bytes)

Identifier-related diagnostics

The identifier-related diagnostics provides a bit (KB_n) for each slot 1 allocated when configuring the device. If a diagnostics message is active at a slot, then it's KB_n = true.

		Bit							
Octet	Name	7	6	5	4	3	2	1	0
1	Header-Byte Station status 1	0	1	Block length (2 ... 32) incl. this byte					
2	Bit structure	KB_7	KB_6	KB_5	KB_4	KB_3	KB_2	KB_1	KB_0
3	Bit structure	KB_11	KB_10	KB_9	KB_8
...		...							
x	Bit structure	KB_n+1	KB_n

Status messages/module status

Status messages and module status briefly represent an overview of the state of the devices:

		Bit							
Octet	Name	7	6	5	4	3	2	1	0
1	Header byte	0	0	Block length (2 ... 32) incl. this byte					
2	Module status	0x82							
3	Slot	0							
4	Specifier	0							
5		Slot_4		Slot_3		Slot_2		Slot_1	
6		...		Slot_7		Slot_6		Slot_5	
...		...							
x		00		Slot_n		

Note

Status value

Diagnostics for SINAMICS are only available in cyclic PROFIBUS operation, so that the state 00 = "Valid useful data" is always output for all slots.

Channel-related diagnostics

Channel-related diagnostics encompasses the following data:

		Bit	7	6	5	4	3	2	1	0
Octet	Name									
x	Header-Byte	1 ¹⁾	0 ¹⁾	0 ... 63 (module number) including this byte						
x + 1		1 ²⁾	1 ²⁾	0 (no component assignment)						
x + 2		0 ³⁾	0 ³⁾	Message classes: 2 undervoltage 3 overvoltage 9 error 16 Hardware/software error 17 Line supply/filter faulted 18 DC-link overvoltage 19 Power electronics faulted 20 Electronic component overtemp. 21 Ground/phase fault detected 22 Motor overload 23 Commun. with controller faulted 24 Safety monit. Detected an error 25 Act. Position/speed value error 26 Internal communication faulted 27 Infeed faulted 28 Braking controller faulted 29 External signal state error 30 Application/function faulted 31 Parameterization/commiss. error						

1) ≙ Channel-related diagnostics

2) ≙ Input/output

3) ≙ "Channel type "non specific"

System response

Only one signal is generated if channel-related diagnostics identifies several faults belonging to the same message class at the same drive object.

Data sets DS0/DS1 and diagnostics alarm

The PROFIdrive message classes are transferred using diagnostic alarm DS0/DS1. All faults are assigned channel 0. The drive objects are assigned using the slot number.

The structure is as follows:

Bit		7	6	5	4	3	2	1	0	
Octet	Name									
1	Header-Byte	0	0	= 15 (block length)						
2		0	= 1 (diagnostics alarm)							
3		0 ... 244 (slot number $\hat{=}$ drive object)								
4		0 ... 31 (sequence number)						Add_Ack	Alarm_Specifier ¹⁾	
5	DS0 (byte 0)	0	0	0	0	1 ²⁾	0	1 ³⁾	1 ⁴⁾	
6	DS0 (byte 1)	0	0	0	1 ⁵⁾	0 ⁶⁾	0 ⁶⁾	1 ⁶⁾	1 ⁶⁾	
7	DS0 (Byte 2)	0	0	0	0	0	0	0	0	
8	DS0 (byte 3)	0	0	0	0	0	0	0	0	
9	Info (byte 1)	Mixed	= 0x45 (ChannelTypeID = SINAMICS)							
10	Info (byte 2)	= 24 (number of diagnostic bits/channel)								
11	Info (byte 3)	= 1 (1 channel signals)								
12	Channel Error Vector	0	0	0	0	0	0	0	Channel 0 1	
13	Channel -related diag- nostics (channel 0)	Err 7	Err 6	Err 5	Err 4	Err 3	Err 2	Err 1	Err 0	
14		Err 15	Err 14	Err 13	Err 12	Err 11	Err 10	Err 9	Err 8	
15		0	0	0	0	Err 19	Err 18	Err 17	Err 16	

- 1) Alarm_Specifier
 - 1 $\hat{=}$ error has occurred and the slot is not OK
 - 2 $\hat{=}$ error is resolved and the slot is OK
 - 3 $\hat{=}$ error is resolved and the slot is not okay
- 2) Channel fault present
 - = 1; as long as the drive object has an error condition
- 3) Internal fault
 - = 1; as long as the drive object has an error condition
- 4) Module fault
 - = 1; as long as the drive object has an error condition
- 5) Channel information present
 - = 1; $\hat{=}$ DS1 exists
- 6) Type class of module
 - = 0011; $\hat{=}$ Distributed

11.2 Communication via PROFIBUS DP

11.2.1 General information about PROFIBUS

11.2.1.1 General information about PROFIBUS for SINAMICS

PROFIBUS is an open international fieldbus standard for a wide range of production and process automation applications.

The following standards ensure open, multi-vendor systems:

- International standard EN 50170
- International standard IEC 61158

PROFIBUS is tuned for high-speed, time-critical data communication at field level.

Note

PROFIBUS for drive technology is standardized and described in the following document:
PROFIdrive Profile Drive Technology

PROFIBUS User Organization e. V.
Haid-und-Neu-Strasse 7, D-76131 Karlsruhe

Internet: (<http://www.profibus.com>)

Note

Before synchronizing to the isochronous PROFIBUS, all of the drive object pulses must be inhibited - also for those drives that are not controlled via PROFIBUS.

PROFIBUS interface: The cyclic PZD channel is deactivated when the **CBE20** is plugged in!

NOTICE
Destruction of the CU320-2 or other CAN bus nodes by connecting a CAN cable
Connecting a CAN cable to interface X126 of the CU320-2 can destroy the CU320-2 or other CAN bus nodes.
<ul style="list-style-type: none">• Do not connect any CAN cable to the X126 interface.

Master and slave

- Master and slave properties

Properties	Master	Slave
As bus node	Active	Passive
Send messages	Permitted without external request	Only possible on request by master
Receive messages	Possible without any restrictions	Only receive and acknowledge permitted

- Master

The following classes are differentiated:

- Master class 1 (DPMC1):

Central automation stations that exchange data with the slaves in cyclic and acyclic mode. Communication between the masters is also possible.

Examples: SIMATIC S7, SIMOTION

- Master class 2 (DPMC2):

Devices for configuration, commissioning, operator control and monitoring during bus operation. Devices that only exchange data with the slaves in acyclic mode.

Examples: Programming devices, human machine interfaces

- Slaves

With respect to PROFIBUS, the SINAMICS drive unit is a slave.

Bus access method

PROFIBUS uses the token passing method, i.e. the active stations (masters) are arranged in a logical ring in which the authorization to send is received within a defined time frame.

Within this time frame, the master with authorization to send can communicate with the assigned slaves and/or with other masters in a master/slave procedure.

PROFIBUS telegram for cyclic data transmission and acyclic services

Each drive unit that supports cyclic process data exchange uses a telegram to send and receive all the process data. A separate telegram is sent in order to perform all the acyclic services (read/write parameters) under a single PROFIBUS address. The acyclic data is transferred with a lower priority after cyclic data transmission.

The overall length of the telegram increases with the number of drive objects that are involved in exchanging process data.

Sequence of drive objects in the telegram

On the drive side, the sequence of drive objects in the telegram is displayed via a list in p0978[0...24] where it can also be changed.

You can use the STARTER commissioning tool to display the sequence of drive objects for a commissioned drive system in the project navigator under "Drive unit" > "Communication" > "Telegram configuration".

When you create the configuration on the controller side (e.g. HW Config), the process-data-capable drive objects for the application are added to the telegram in the shown sequence (see above).

The following drive objects can exchange process data:

- Active Infeed (A_INF)
- Basic Infeed (B_INF)
- Control Unit (CU_S)
- ENC
- Smart Infeed (S_INF)
- SERVO
- Terminal Board 30 (TB30)
- Terminal Module 15 (TM15)
- Terminal Module 31 (TM31)
- Terminal Module 41 (TM41)
- Terminal Module 120 (TM120)
- Terminal Module 150 (TM150)
- VECTOR

Note

The sequence of drive objects in HW Config must be the same as that in the drive (p0978).

Drive objects after the first zero in p0978 must not be configured in the HW Config.

The structure of the telegram depends on the drive objects taken into account during configuration. Configurations are permitted that do not take into account all of the drive objects that are present in the drive system.

Example:

The following configurations, for example, are possible:

- Configuration with SERVO, SERVO, SERVO
- Configuration with A_INF, SERVO, SERVO, SERVO, TB30
- etc.

11.2.1.2 Example: telegram structure for cyclic data transmission

Task

The drive system comprises the following drive objects:

- Control Unit (CU_S)
- Active Infeed (A_INF)
- SERVO 1 (comprises a Single Motor Module and other components)
- SERVO 2 (comprises a Double Motor Module terminal X1 and other components)
- SERVO 3 (comprises a Double Motor Module terminal X2 and other components)
- Terminal Board 30 (TB30)

The process data is to be exchanged between the drive objects and the higher-level automation system.

Telegrams to be used:

- Telegram 370 for Active Infeed
- Standard telegram 6 for SERVO
- User-defined for Terminal Board 30 for the three SERVO drives

Component and telegram structure

The predefined component structure results in the telegram structure shown in the following diagram.

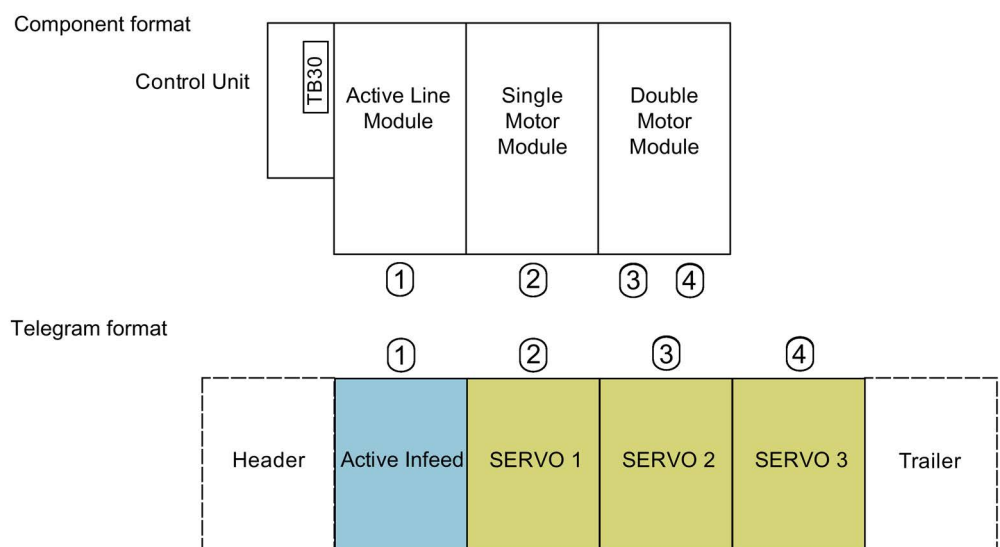

Figure 11-11 Component and telegram structure

You can check and change the sequence of the telegrams via p0978[0...24].

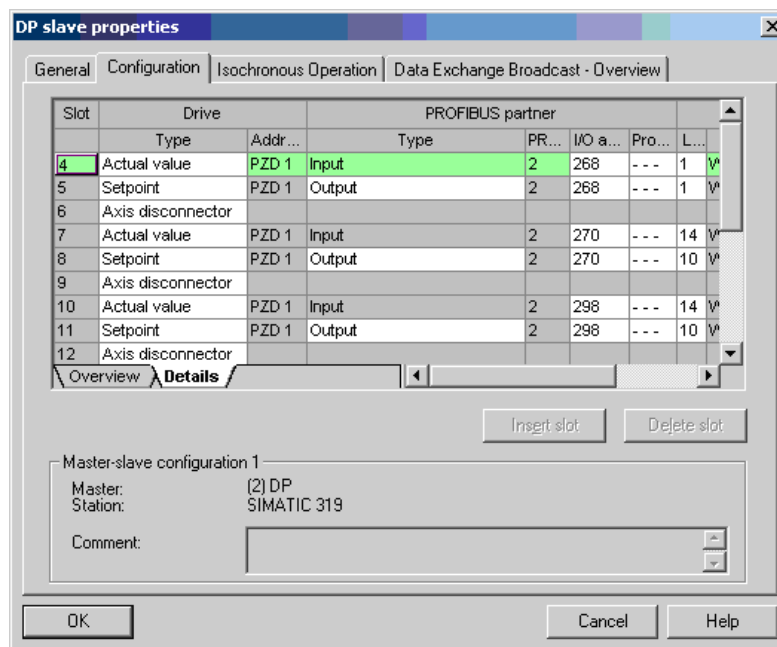

Figure 11-13 Slave properties – details

The axis separator separates the objects in the telegram as follows:

- Slots 4 and 5: Object 1 → Active Infeed (A_INF)
 - Slots 7 and 8: Object 2 → SERVO 1
 - Slots 10 and 11: Object 3 → SERVO 2
- etc.

11.2.2 Commissioning PROFIBUS

11.2.2.1 Setting the PROFIBUS interface

Interfaces and diagnostic LED

A PROFIBUS interface with LEDs and address switches is available as standard on the CU320-2 DP Control Unit.

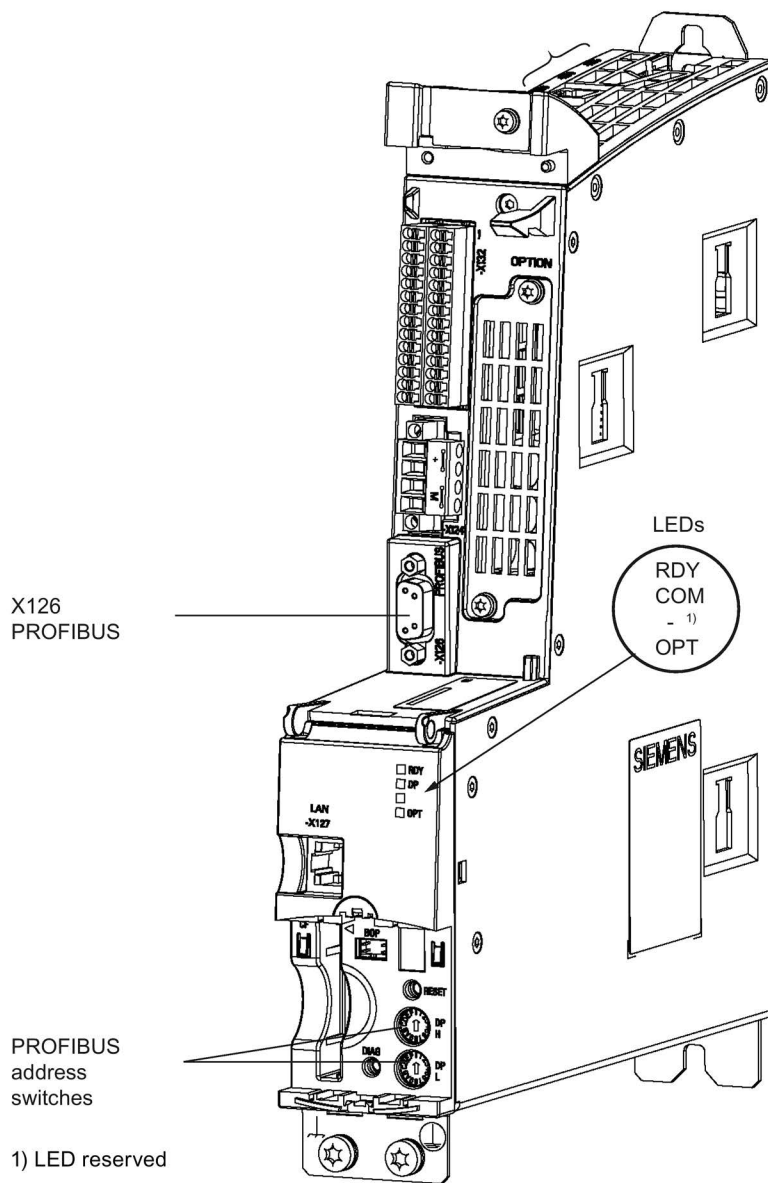

Figure 11-14 Interfaces and diagnostic LED



- PROFIBUS interface
The PROFIBUS is described in the "SINAMICS S120 Control Units and Supplementary System Components Manual".
- PROFIBUS diagnostic LED

Note

A teleservice adapter can be connected to the PROFIBUS interface (X126) for remote diagnostics purposes.

On the CU320-2 DP, the PROFIBUS address is set as a hexadecimal value via two rotary coding switches. Values between 0_{dec} (00_{hex}) and 127_{dec} (7F_{hex}) can be set as the address. The upper rotary coding switch (H) is used to set the hexadecimal value for 16¹ and the lower rotary coding switch (L) is used to set the hexadecimal value for 16⁰.

Table 11- 7 PROFIBUS address switch

Rotary coding switches	Significance	Examples		
		21 _{dec}	35 _{dec}	126 _{dec}
		15 _{hex}	23 _{hex}	7E _{hex}
 DP H	16 ¹ = 16	1	2	7
 DP L	16 ⁰ = 1	5	3	E

Setting the PROFIBUS address

The factory setting for the rotary coding switches is 0_{dec} (00_{hex}).

There are two ways to set the PROFIBUS address:

1. Using a parameter

- To set the bus address for a PROFIBUS node using STARTER, first set the rotary code switches to 0_{dec} (00_{hex}) and/or 127_{dec} (7F_{hex}).
- Use the parameter to set the address to a value between 1 and 126.

Information can be taken from the following reference:

Reference: /LH1/ SINAMICS S120/S150 List Manual

2. Using the PROFIBUS address switches on the Control Unit

- The address is set manually to values between 1 and 126 using the rotary coding switches. In this case, the parameter is only used to read the address.

Note

The rotary coding switches used to set the PROFIBUS address are located beneath the cover.

Note

Address 126 is used for commissioning. Permitted PROFIBUS addresses are 1 ... 126.

When several Control Units are connected to a PROFIBUS line, you set the addresses differently than for the factory setting. Each PROFIBUS address in a PROFIBUS line can only be assigned once. Either set the PROFIBUS address in absolute terms using the rotary coding switches – or selectively in parameter p0918. Each change made to the bus address is not effective until POWER ON.

The currently set address of the rotary coding switch is displayed in parameter r2057.

Note

Only values from 1 to 126 (7E_{hex}) are valid for PROFIBUS addressing. If values above 127 are set, then the set value is interpreted as "0". If a value "0" or "127" is set, the value in parameter p0918 defines the PROFIBUS address.

11.2.2.2 PROFIBUS interface in operation

Generic station description file

A generic station description file clearly and completely defines the properties of a PROFIBUS slave.

The SINAMICS S GSD file contains among other things standard telegrams, free telegrams and slave-to-slave telegrams for configuring slave-to-slave communication. With the aid of these telegram parts and an axis separator, a telegram for the drive unit must be composed for each drive object.

The GSD files can be found:

- On the Internet:
 - PROFINET I/O (<http://support.automation.siemens.com/WW/view/en/49217480>) (GSDML files)
 - PROFIBUS DP (<http://support.automation.siemens.com/WW/view/en/49216293>) (GSD files)
- On the CD/DVD of the STARTER commissioning tool
Article number 6SL3072-0AA00-0AG.
- On the memory card in the directory:
\\SIEMENS\SINAMICS\DATA\CFG\

The integration of a GSD file in HW Config is covered in the SIMATIC documentation. Suppliers of PROFIBUS components can provide their own bus configuration tool. The operation of the respective bus configuration tool is described in the relevant documentation.

Note for commissioning for VIK-NAMUR

To be able to operate a SINAMICS drive as a VIK-NAMUR drive, standard telegram 20 must be set and the VIK-NAMUR identification number activated via p2042 =1.

Device identification

Identification for individual slaves facilitates diagnostics and provides an overview of the nodes on the PROFIBUS.

The information for each slave is stored in the following CU-specific parameter:
r0964[0...6] device identification

Bus terminating resistor and shielding

Reliable data transmission via PROFIBUS depends, amongst other things, on the setting of the bus terminating resistors and the shielding of the PROFIBUS cables.

- Bus terminating resistor
 - The bus terminating resistors in the PROFIBUS plugs must be set as follows:
 - First and last nodes in the line: Switch on terminating resistor
 - Other nodes in the line: Switch off terminating resistor
- Shielding of the PROFIBUS cables
 - The cable shield must be connected in the plug through a large surface area at both ends (see SINAMICS S120 Control Units and Supplementary System Components Manual).

11.2.2.3 Commissioning PROFIBUS

Preconditions and assumptions for commissioning

	Requirement
PROFIBUS slave	<ul style="list-style-type: none"> • The PROFIBUS address to be set for the device application is known. • The telegram type for each drive object is known by the application.
PROFIBUS master	<ul style="list-style-type: none"> • The communication properties of the SINAMICS S120 slave must be available in the master (GSD file or Drive ES slave OM).

Commissioning steps (example with SIMATIC S7)

1. Set the PROFIBUS address on the slave.
2. Set the telegram type on the slave.
3. Perform the following in HW Config:
 - Connect the drive unit to PROFIBUS and assign the address.
 - Set the telegram type.

The same telegram type as on the slave should be set for every drive object exchanging process data via PROFIBUS.

The master can send more process data than the slave uses. A telegram with a larger PZD number than is assigned for the drive object STARTER can be configured on the master.

The PZDs not supplied by the drive object are filled with zeros.

The setting "without PZD" can be defined on a node or object (e.g. infeed controlled via terminals).

4. Assign the I/O addresses according to the user program.

11.2.2.4 Diagnostics options

The standard slave diagnostics can be read online in the HW config.

11.2.2.5 SIMATIC HMI addressing

You can use a SIMATIC HMI as a PROFIBUS master (master class 2) to access SINAMICS directly. With respect to SIMATIC HMI, SINAMICS behaves like a SIMATIC S7. For accessing drive parameters, the following applies:

- Parameter number = data block number
- Parameter sub-index = bit 0 ... 9 of data block offset
- Drive object number = bit 10 ... 15 of data block offset

Pro Tool and WinCC flexible

The SIMATIC HMI can be configured flexibly with "Pro Tool" or "WinCC flexible".

The following specific settings for drives must be observed when configuration is carried out with Pro Tool or WinCC flexible.

Controllers: Protocol always "SIMATIC S7 - 300/400"

Table 11- 8 Additional parameters

Field	Value
Network parameter profile	DP
Network parameter baud rate	Any
Communication partner address	PROFIBUS address of the drive unit
Communication partner slot/rack	Don't care, 0

Table 11- 9 Variables: "General" tab

Field	Value
Name	Any
Controller	Any
Type	Depending on the addressed parameter value, e.g.: INT: for integer 16 DINT: for integer 32 WORD: for unsigned 16 REAL: for float
Area	DB
DB (data block number)	Parameter number 1 ... 65535
DBB, DBW, DBD (data block offset)	Drive object No. and sub-index bit 15 ... 10: Drive object No. 0 ... 63 bit 9 ... 0: Sub-index 0 ... 1023 or expressed differently DBW = 1024 * drive object No. + sub-index
Length	Not activated
Acquisition cycle	Any
Number of elements	1
Decimal places	Any

Note

- You can operate a SIMATIC HMI together with a drive unit independently of an existing controller.
A basic "point-to-point" connection can only be established between two nodes (devices).
- The "variable" HMI function can be used for drive units. Other functions cannot be used (e.g. "messages" or "recipes").
- Individual parameter values can be accessed. Entire arrays, descriptions, or texts cannot be accessed.

11.2.2.6 Monitoring telegram failure

When monitoring the telegram failure, SINAMICS differentiates between two cases:

- Telegram failure with a bus fault

After a telegram failure and the additional monitoring time has elapsed (p2047), bit r2043.0 is set to "1" and alarm A01920 is output. Binector output r2043.0 can be used for a quick stop, for example.

Once the delay time p2044 has elapsed, fault F01910 is output. Fault F01910 triggers fault response OFF2 (pulse inhibit) for the infeed and OFF3 (quick stop) for SERVO/VECTOR. If no OFF response is to be triggered, the fault response can be reparameterized accordingly.

Fault F01910 can be acknowledged immediately. The drive can then be operated even without PROFIdrive.

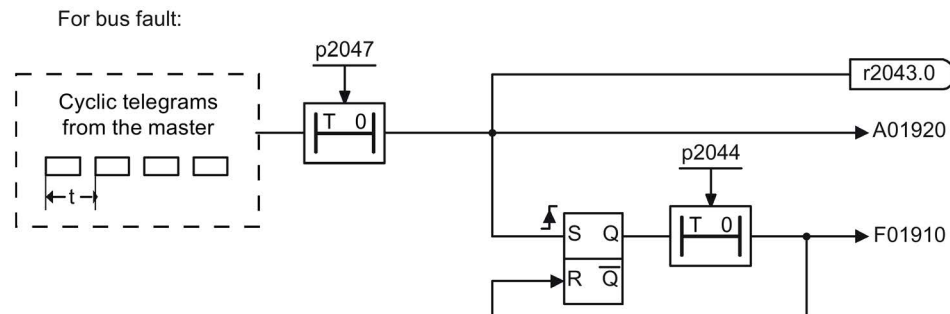

Figure 11-15 Monitoring telegram failure with a bus fault

- Telegram failure with a CPU stop

After telegram failure, bit r2043.0 is set to "1". Binector output r2043.0 can be used for a quick stop, for example.

Once the delay time p2044 has elapsed, fault F01910 is output. Fault F01910 triggers fault response OFF2 (pulse inhibit) for the infeed and OFF3 (quick stop) for SERVO/VECTOR. If no OFF response is to be triggered, the fault response can be reparameterized accordingly.

Fault F01910 can be acknowledged immediately. The drive can then be operated even without PROFIdrive.

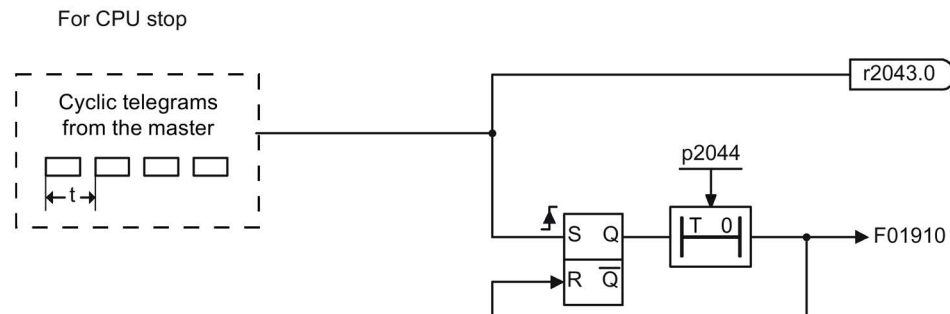

Figure 11-16 Monitoring telegram failure for a CPU stop

Example: Quick stop at telegram failure

Assumption:

- A drive unit with an Active Line Module and a Single Motor Module.
- VECTOR mode is activated.
- After a ramp-down time (p1135) of two seconds, the drive is at a standstill.

Settings:

CU p2047 = 20 ms

A_INF p2044 = 2 s

VECTOR p2044 = 0 s

Sequence:

1. Following a telegram failure and once the additional monitoring time (p2047) has elapsed, binector output r2043.0 of drive object CU switches to "1".

At the same time, alarm A01920 is output for the A_INF drive objects and alarm A01920 and fault F01910 are output for VECTOR.
2. When F01910 is output, an OFF3 is triggered for the drive.
3. After a two-second delay time (p2044), fault F01910 is output on the infeed and triggers OFF2.

Designations and descriptions for motion control

Table 11- 10 Time settings and meanings

Name	Limit value	Description
T _{BASE_DP}	250 µs	Time base for T _{DP}
T _{DP}	T _{DP} ≥ T _{DP_MIN} T _{DP_MIN} ≤ T _{DP} ≤ T _{DP_MAX}	DP cycle time T _{DP} = Dx + MSG + RES + GC T _{DP} = multiple integer • T _{BASE_DP} T _{DP_MIN} = 1 ms T _{DP_MAX} = 32 ms
T _{MAPC}		Master application cycle time This is the time frame in which the master application generates new setpoints (e.g. in the position controller cycle). T _{MAPC} = integer multiple of T _{DP}
T _{BASE_IO}	125 µs	Time base for T _I , T _O
T _I	T _{I_MIN} ≤ T _I < T _{DP}	Time of actual-value sensing This is the time at which the actual position value is captured before the start of each cycle. T _I = integer multiple of T _{BASE_IO} T _{I_MIN} corresponds to the longest current controller cycle (p0115[0]) of a drive object (SERVO/VECTOR) in the drive unit, minimum 125 µs. Does not apply to vector V/f.
T _O	T _{DX} + T _{O_MIN} ≤ T _O < T _{DP}	Time of setpoint transfer This is the time at which the transferred setpoints (speed setpoint) are accepted by the closed-loop control system after the start of the cycle. T _O = integer multiple of T _{BASE_IO} T _{O_MIN} corresponds to the longest speed controller cycle (p0115[1]) of a drive object (SERVO/VECTOR) in the drive unit, minimum 125 µsec
T _{DX}	T _{DX} < T _{DP}	Data exchange time This is the time required within one cycle for transferring process data to all available slaves.
T _{PLL_W}	-	PLL window
T _{PLL_D}	-	PLL delay time
GC		Global Control Telegram (broadcast telegram)
Dx		Data_Exchange This service is used to implement user data exchange between master and slave 1 - n.
MSG		Acyclic service This service is used to implement user data exchange between master and slave 1 - n on an acyclic basis.
RES		Reserve: "Active pause" until the isochronous cycle has expired
R		Computation time, speed or position controller in the master or slave
T _M		Master time Start of closed-loop master control

Setting criteria for times

- Cycle (T_{DP})
 - T_{DP} must be set to the same value for all bus nodes.
 - $T_{DP} > T_{DX}$ and $T_{DP} > T_O$

Note

After T_{DP} has been changed on the PROFIBUS master, the drive system must be switched on (POWER ON) or parameter $p0972 = 1$ (reset drive unit) must be set.

- T_I and T_O
 - Setting the times in T_I and T_O as short as possible reduces the dead time in the position control loop.
 - $T_O > T_{DX} + T_{Omin}$
- Settings and tuning can be done using a tool (e.g. HW Config in SIMATIC S7).

Minimum times for reserves

Table 11- 11 Minimum times for reserves

Data	Time required [μ s]
Basic load	300
Per slave	20
Per byte of user data	1.5
One additional class 2 master	500

User data integrity

User data integrity is verified in both transfer directions (master \longleftrightarrow slave) by a sign-of-life (4-bit counter).

The sign-of-life counters are incremented from 1 to 15 and then start again at an arbitrary value between 1 and 15.

- Master sign-of-life
 - STW2.12 ... STW2.15 are used for the master sign-of-life.
 - The master sign-of-life counter is incremented on each master application cycle (T_{MAPC}).
 - The number of tolerated master sign-of-life errors in succession (of an isochronous motor) can be set via p0925
 - p0925 = 65535 deactivates sign-of-life monitoring on the slave.
 - Monitoring

The master sign-of-life is monitored on the slave and any sign-of-life errors are evaluated accordingly.

The maximum number of tolerated master sign-of-life errors can be set via p0925.

If the number of tolerated sign-of-life errors in succession set in p0925 is exceeded, the response is as follows:

 - A corresponding message is output.
 - The value zero is output as the slave sign-of-life.
 - Synchronization with the master sign-of-life is started.
- Slave sign-of-life
 - ZSW2.12 ... ZSW2.15 are used for the slave sign-of-life.
 - The slave sign-of-life counter is incremented in each DP cycle (T_{DP}).

Example: SINAMICS vector drives with SIMOTION D4x5 and/or CX modules

To determine which cycles in the SINAMICS drive unit will be set after a project has been downloaded, dependable cycle values should be initially set in HW Config.

The following settings and sequences are recommended:

1. $T_{DP} = 3.0 \text{ ms}$ (T_{DP} = DP cycle time)
2. $T_I = T_o = 1.5 \text{ ms}$ (T_I = time of actual value acquisition, T_o = time of setpoint transfer)
3. $T_{MAPC} = 6.0 \text{ ms}$ (T_{MAPC} = master application cycle time)

After a successful download, all current and speed controller cycles are visible. These cycles can be optimized in HW Config if necessary.

The cycles are set in HW Config under the DP slave properties of the SINAMICS drive unit (slave, master e.g. SIMOTION D4x5) under the "Clock synchronization" tab.

11.2.4 Slave-to-slave communication

For PROFIBUS DP, the master interrogates all of the slaves one after the other in a DP cycle. In this case, the master transfers its output data (setpoints) to the particular slave and receives as response the input data (actual values). Fast, distributed data transfer between drives (slaves) is possible using the "slave-to-slave communication" function without direct involvement from the master.

The following terms are used for the function described in this chapter:

- Slave-to-slave communication
- Data Exchange Broadcast (DXB.req)
- Slave-to-slave communication (is used in the following)

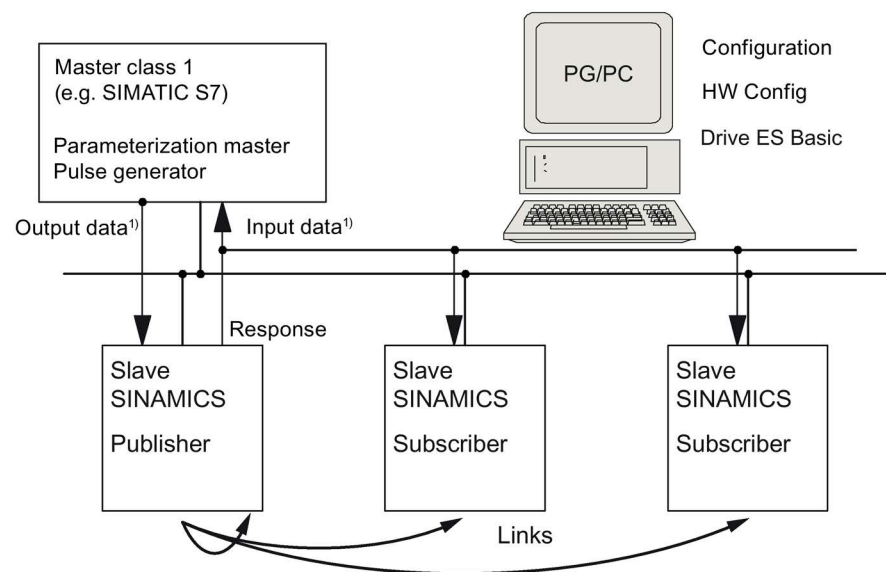

1) From the perspective of the Class 1 master

Figure 11-18 Slave-to-slave communication with the publisher-subscriber model

Publisher

With the "slave-to-slave communication" function, at least one slave must act as the publisher.

The publisher is addressed by the master when the output data is transferred with a modified layer 2 function code (DXB.req). The publisher then sends its input data for the master with a broadcast telegram to all bus nodes.

Subscriber

The subscribers evaluate the broadcast telegrams, sent from the publishers, and use the data which has been received as setpoints. These setpoints of the publisher are used, in addition to the setpoints received from the master, corresponding to the configured telegram structure (p0922).

Links and taps

The links configured in the subscriber (connections to publisher) contain the following information:

- From which publisher is the input data received?
- What is the content of the input data?
- Where are the additional setpoints received?

Several taps are possible within a link. Several input data or input data areas, which are not associated with one another, can be used as setpoint via a tap.

Links to your own drive units are possible. For example, data in a Double Motor Module can be transferred from drive A to drive B. This internal link corresponds, as far as the timing is concerned, to a link via PROFIBUS.

Requirements

The following preconditions should be observed for the "slave-to-slave communication" function:

- STARTER as of Version 4.2
- Configuration:
 - Drive ES Basic, Drive ES SIMATIC or Drive ES PCS7 as of Version 5.3 SP3
 - Alternatively using a GSD file
- Firmware as of Version 4.3
- The maximum number of process data per drive can be identified from the value in r2050
 - minus the resources that have already been used
- A maximum of 16 links to publishers

Note

The "slave-to-slave communication" function is not available for the CU310-2 PN.

Applications

For example, the following applications can be implemented using the "slave-to-slave communication" function:

- Axis couplings (this is practical for isochronous mode)
- Specifying binector connections from another slave

11.2.4.1 Setpoint assignment in the subscriber

Information about setpoints

- Number of setpoint
When bus communication is being established, the master signals the slave the number of setpoints (process data) to be transferred using the configuring telegram (ChkCfg).
- Contents of the setpoints
The structure and contents of the data are determined using the local process data configuration for the "SINAMICS slave".
- Operation as "standard" slave
The drive unit (slave) only receives its setpoints as output data from the master.
- Operation as subscriber
These setpoints of the publisher are used, in addition to the setpoints received from the master, corresponding to the configured telegram structure (p0922).
The slave is informed of the assignment via the parameterization and configuration telegram when bus communication is being established.

11.2.4.2 Activating/parameterizing slave-to-slave communication

The "slave-to-slave communication" function must be activated both in the publishers as well as in the subscribers, whereby only the subscriber is to be configured. The publisher is automatically activated during bus startup.

Activation in the publisher

The master is informed about which slaves are to be addressed as publishers with a modified layer 2 function code (DXB req) via the configuration of the subscriber links.

The publisher then sends its input data not only to the master but also as a broadcast telegram to all bus nodes.

These settings are made automatically using the bus configuration tool (e.g. HW Config).

Activation in the subscriber

The slave, which is to be used as subscriber, requires a filter table. The slave must know which setpoints are received from the master and which are received from a publisher.

The filter table is created automatically via the bus configuration tool (e.g. HW Config).

The following diagram shows the information contained in the filter table.

Parameterizing telegram (SetPrm)

The filter table is transferred, as dedicated block from the master to the slave with the parameterizing telegram when a bus communication is established.

Blockheader	Block-Len ¹⁾	12 – 244
	Command	0xE2
	Slot	0x00
	Specifier	0x00
Filter table Header	Version identifier	0xE2
	Number of links	0 – 3
	Offset Link1 ²⁾	
	...	
Link1	Offset Link n ²⁾	
	Publisher DP address	
Tap1	Publisher input length	
	Offset in the publisher data	
	Target offset in the subscriber	
Tap2	Length of the data access	
	...	
Link2	Publisher DP address	
	...	

1) Specification in bytes
 2) Calculated from Version ID

Figure 11-19 Filter block in the parameterizing telegram (SetPrm)

Configuration telegram (ChkCfg)

Using the configuration telegram, a slave knows how many setpoints are to be received from the master and how many actual values are to be sent to the master.

For slave-to-slave communication, a special space ID is required for each tap. The PROFIBUS configuration tool (e.g. HW Config) generates this ID. The ID is then transferred with the ChkCfg into the drive devices that operate as subscribers.

11.2.4.3 Commissioning PROFIBUS slave-to-slave communication

The commissioning of slave-to-slave communication between two SINAMICS drive devices using the additional Drive ES package is described below in an example.

Settings in HW Config

Based on the example of the project below, the settings in HW Config are described when using standard telegrams.

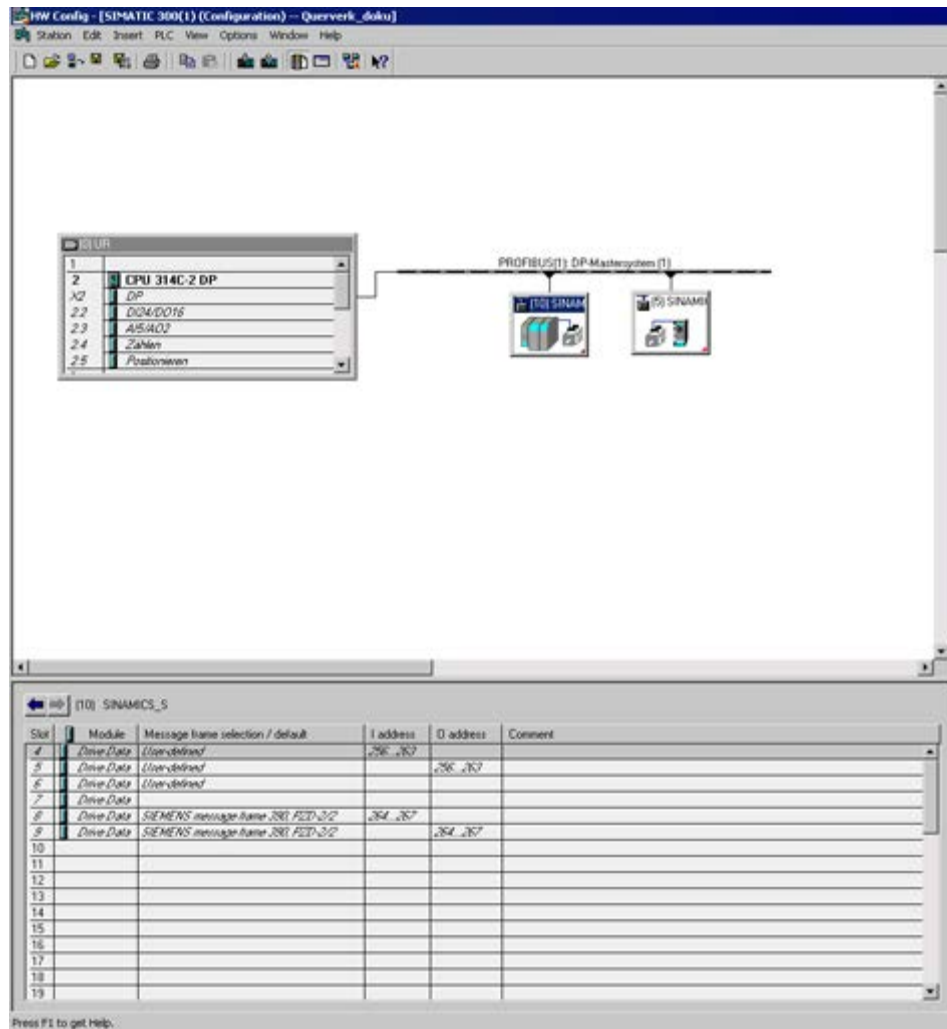

Figure 11-20 Example project of a PROFIBUS network in HW Config

Procedure

1. You have generated a project, e.g. with SIMATIC Manager and HW Config. In the project example, you defined a CPU 314 controller as master and 2 SINAMICS S120 Control Units as slaves. Of the slaves, one CU310-2 DP is the publisher and one CU320-2 DP the subscriber.
2. Select the CU320-2 DP Control Unit as slave.
3. Via its properties dialog in the overview, configure the telegram for the connected drive object.

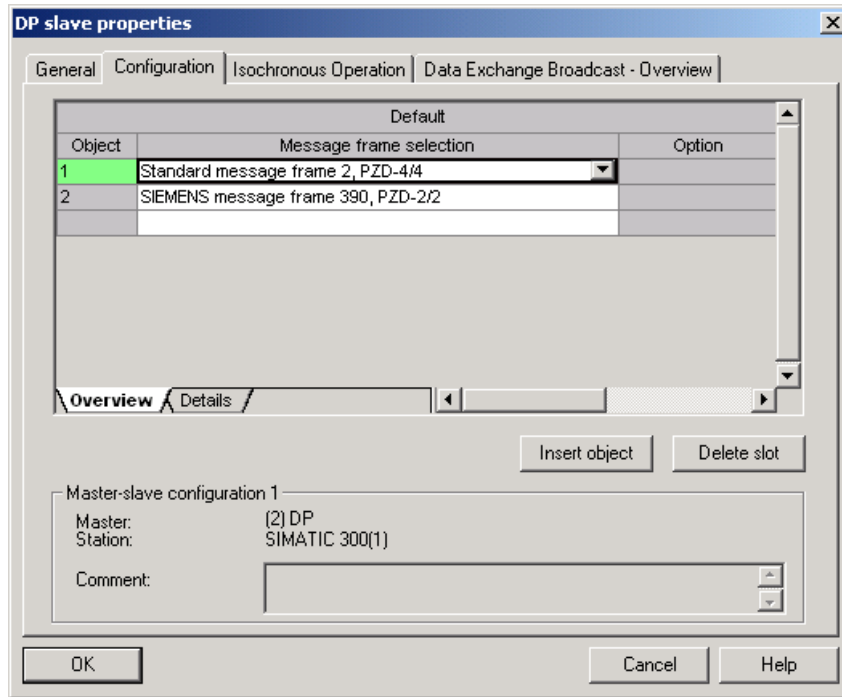

Figure 11-21 Telegram selection for drive object

4. Then switch to the detailed view.
 - Slots 4/5 contain the actual and setpoint values for the first drive object, e.g. SERVO.
 - Slots 7/8 contain the telegram components for the actual values and setpoints for the second drive object, e.g. CU310-2 DP.

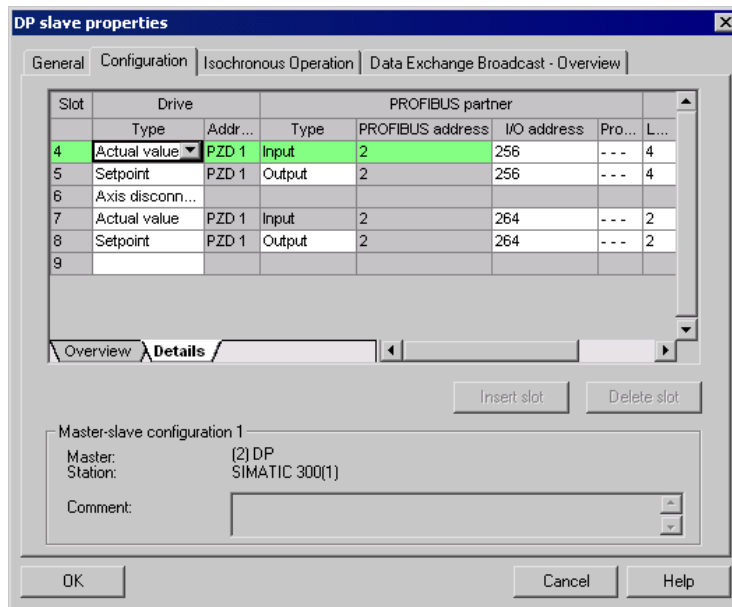

Figure 11-22 Detail view of slave configuration

5. Create an additional setpoint slot 6 for the first drive object using the "Insert slot" button behind the existing setpoint slot 5.

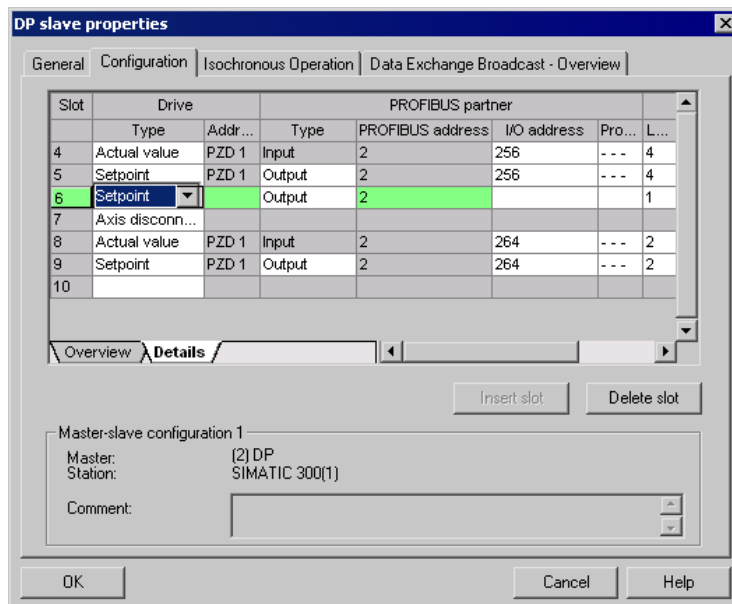

Figure 11-23 Insert new slot

6. Under the "PROFIBUS Partner" column, change the new setpoint slot 6 from an "output" type to a "slave-to-slave communication" type.

7. In the first column, select the PROFIBUS DP address of the publisher, in this example "5".
 All PROFIBUS DP slaves are listed here, for which actual value data can be retrieved. It also provides the possibility of sharing data via slave-to-slave communication within the same drive device.
8. The "I/O address" column displays the start address for every drive object.
 Select the start address of the data of the drive object to be read. In the example, "268" is proposed.
 If the complete data of the publisher is not to be read, set this using the "Length" column. Alternatively, you can shift the start address of the access, so that the required data can be read out from the center section of the telegram component of the drive object.

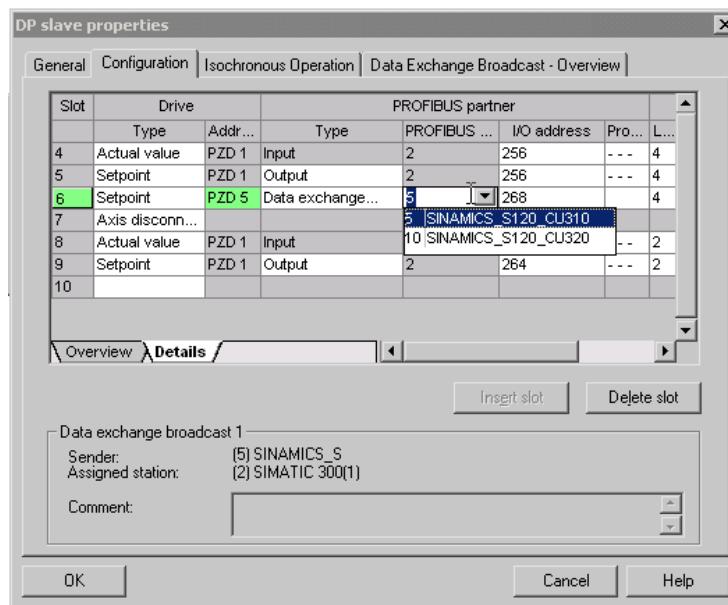

Figure 11-24 Configuring the slave-to-slave communication nodes

- Click the "Slave-to-slave communication overview" tab.

The configured slave-to-slave communication relationships are shown here which correspond to the current status of the configuration in HW Config.

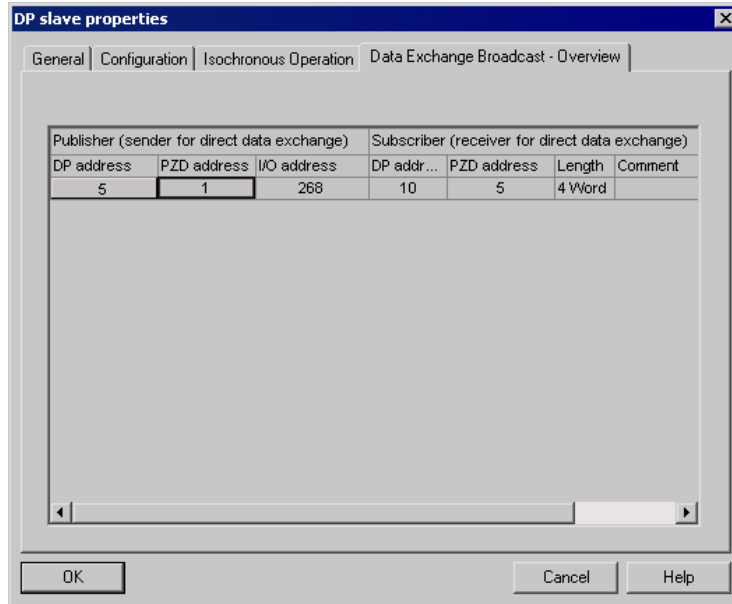

Figure 11-25 Slave-to-slave communication - overview

After the slave-to-slave communication link has been created, instead of showing "Standard telegram 2" for the drive object, "User-defined" appears in the configuration overview under telegram selection.

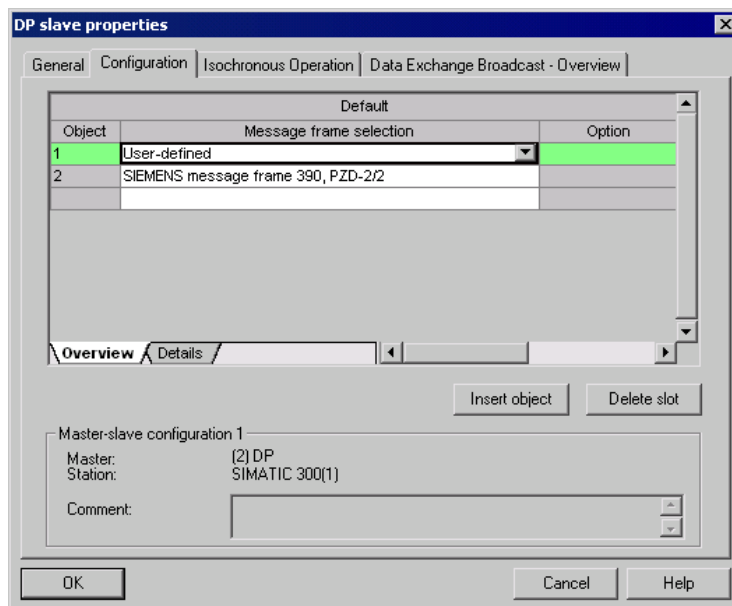

Figure 11-26 Telegram assignment for slave-to-slave communication

The details after creation of the slave-to-slave communication link for a drive object of the drive device are as follows:

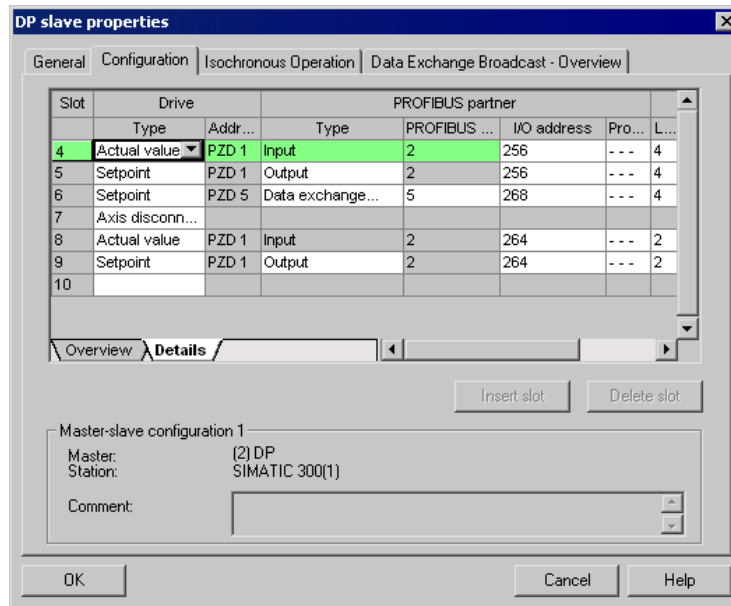

Figure 11-27 Details after the creation of the slave-to-slave communication link

- 10. You should therefore adjust the telegrams for each drive object of the selected drive device that is to participate actively in slave-to-slave communication.

Autodetect in the STARTER

The settings configured in HW Config for the cross-reference telegrams are automatically detected by the STARTER. A telegram extension is not required in the STARTER.

11.2.4.4 Diagnosing the PROFIBUS slave-to-slave communication in STARTER

Since the PROFIBUS slave-to-slave communication is implemented on the basis of a broadcast telegram, only the subscriber can detect connection or data faults, e.g. via the publisher data length (see "Configuration telegram").

The publisher can only detect and report an interruption of the cyclic connection to the DP master (A01920, F01910). The broadcast telegram to the subscriber will not provide any feedback. A fault of a subscriber must be fed back via slave-to-slave communication. In case of a "master drive" 1:n, however, the limited quantity framework (see "Links and requests") should be observed. It is not possible to have n subscribers report their status via slave-to-slave communication directly to the "master drive" (publisher).

Diagnostics can be performed using the diagnostic parameters r2075 ("Receive PROFIBUS diagnostics telegram offset PZD") and r2076 ("Send PROFIBUS diagnostics telegram offset PZD"). The parameter r2074 ("PROFIBUS diagnostics, receive bus address PZD") displays the DP address of the setpoint source of the respective PZD.

r2074 and r2075 enable the source of a slave-to-slave communication relationship to be verified in the subscriber.

Note

The subscribers do not monitor the existence of an isochronous publisher sign-of-life.

Faults and alarms with PROFIBUS slave-to-slave communication

The alarm A01945 signals that the connection to a least one publisher of the drive device is missing or has failed. Any interruption to the publisher is also reported by the fault F01946 at the affected drive object. A failure of the publisher only impacts the respective drive objects.

More detailed information on the messages can be found in the SINAMICS S120/S150 List Manual.

11.2.5 Messages via diagnostics channels

Messages can be displayed not only via the well-known commissioning tools (STARTER, SCOUT). After the activation of a diagnostic function, the messages are also transferred to the higher-level controller via the standardized PROFIdrive fault classes. The messages are evaluated there or forwarded for convenient display to the corresponding user interfaces (SIMATIC HMI, TIA Portal, etc.).

In this way, problems or faults can be located immediately regardless of the tool currently being used, and then corrected immediately.

Also note the general information on the diagnostics channels in Section Diagnostics channels (Page 734).

Activating the diagnostic function

The diagnostics function is activated or deactivated via the parameterization of the relevant configuration tool (HW Config, TIA Portal, etc.).

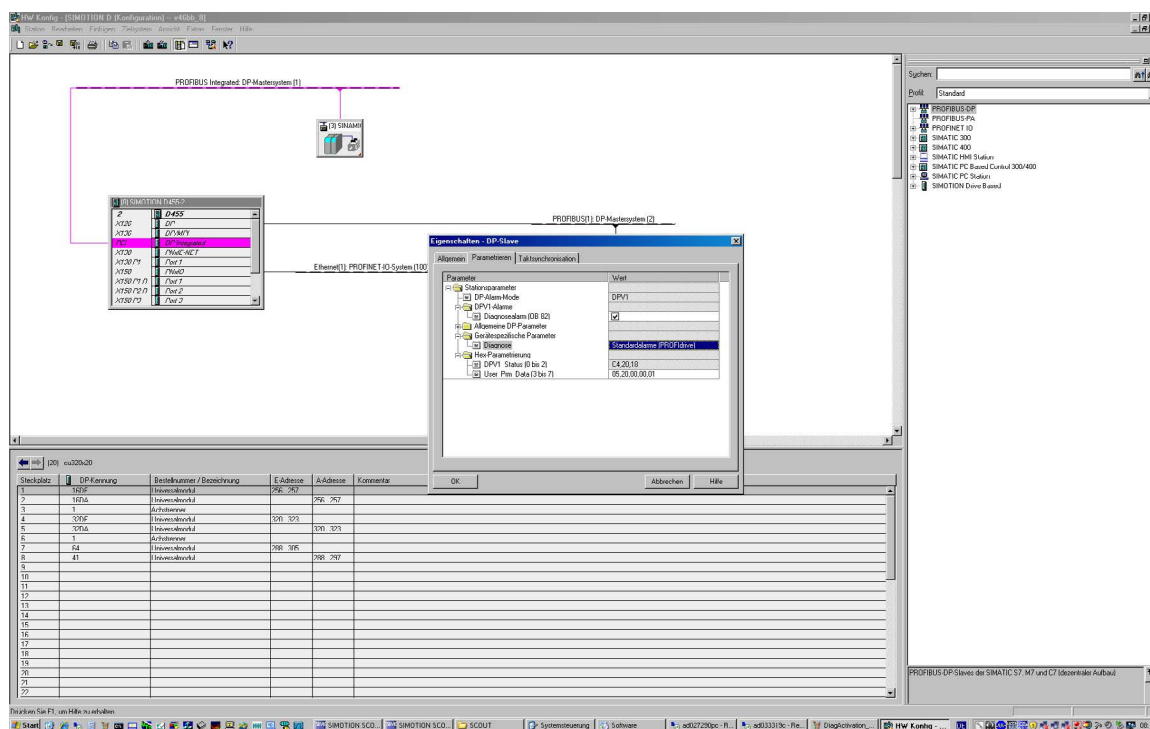

Figure 11-28 Activation of PROFIBUS

The following parameter assignments are possible:

Setting	Code for parameter assignment
Inactive	0
PROFIdrive error classes	1

When establishing the communication between SINAMICS and a master/controller, the activated diagnostics mode of this master/controller is first transferred to the drive. With activated diagnostics, SINAMICS first transfers all pending messages to the master/controller.

Messages

The message texts are described in detail in the SINAMICS S120/S150 List Manual, Section 4.1.2 "Explanations on the list of faults and alarms". A current list of the message texts can be found in the "Message classes and coding of different diagnostics interfaces" table.

11.3 Communication via PROFINET IO

11.3.1 General information about PROFINET IO

PROFINET IO is an open Industrial Ethernet standard for a wide range of production and process automation applications. PROFINET IO is based on Industrial Ethernet and observes TCP/IP and IT standards.

Deterministic signal processing in real time is important in industrial networks. PROFINET IO satisfies these requirements.

The international standard IEC 61158 ensures open, multi-vendor systems:

PROFINET IO is tuned for high-speed, time-critical data transfers at field level.

PROFINET IO

Within the context of Totally Integrated Automation (TIA), PROFINET IO is the systematic development of the following systems:

- PROFIBUS DP, the established fieldbus,
- Industrial Ethernet, the communications bus for the cell level.

Experience gained from both systems was integrated into PROFINET IO. An Ethernet-based automation standard defined by PROFIBUS International (PROFIBUS user organization), PROFINET IO is a manufacturer-independent communication and engineering model.

PROFINET IO defines every aspect of the data exchange between IO controllers (devices with so-called "master functionality" and the IO devices (devices with so-called "slave functionality") as well as carrying out parameterization and diagnostics. A PROFINET IO system is configured in virtually the same way as a PROFIBUS system.

A PROFINET IO system is assembled from the following devices:

- An IO controller controls automation tasks.
- An IO device is controlled and monitored by an IO controller. An IO device can consist of several modules and submodules.
- An IO supervisor is an engineering tool, typically based on a PC, to configure and diagnose the individual IO devices (drive units).

IO devices: Drive units with PROFINET interface

- SINAMICS S120 with CU320-2 DP and inserted CBE20
- SINAMICS S120 with CU320-2 PN
- SINAMICS S120 with CU310-2 PN

Cyclic communication using PROFINET IO with IRT or using RT is possible on all drive units equipped with a PROFINET interface. This means that error-free communication using other standard protocols is guaranteed within the same network.

Note

PROFINET for drive technology is standardized and described in the following document:

PROFIBUS profile PROFIdrive - Profile Drive Technology

Version V4.1, May 2006

PROFIBUS User Organization e. V.

Haid-und-Neu-Straße 7

D-76131 Karlsruhe

Internet: (<http://www.profibus.com>)

Order no. 3.172, spec. Section 6

- IEC 61800-7
-

Note

For CU320-2 DP with inserted CBE20, the cyclic PZD channel for PROFIBUS DP is deactivated. When setting parameter p8839 = 1, the PZD channel can be reactivated (see Section "Parallel operation of communication interfaces (Page 716)").

11.3.1.1 Real-time (RT) and isochronous real-time (IRT) communication

Real-time communication

When communication takes place via TCP/IP, the resultant transmission times may be too long and not defined to meet the production automation requirements. When communicating time-critical IO user data, PROFINET IO therefore uses its own real-time channel, rather than TCP/IP.

Real time means that a system processes external events over a defined period.

Determinism

Determinism means that a system will react in a predictable ("deterministic") manner. With PROFINET IO with IRT, it is possible to precisely determine (predict) transmission times.

PROFINET IO with RT (Real Time)

Real-time data is treated with a higher priority than TCP(UDP)/IP data. Transmission of time-critical data takes place at guaranteed time intervals. RT communication provides the basis for data exchange with PROFINET IO.

PROFINET IO with IRT (Isochronous Real Time)

Isochronous real time: Real time property of PROFINET IO where IRT telegrams are transferred deterministically via planned communication paths in a defined sequence to achieve the best possible synchronism and performance between the IO controller and IO device (drive unit). IRT is also known as time-scheduled communication whereby knowledge about the network structure (topology) is utilized. IRT requires special network components that support planned data transfer.

SINAMICS cycle times of minimum 250 µs (onboard) / 500 µs (CBE20) and a jitter accuracy of less than 1 µs can be achieved when this transmission method is implemented.

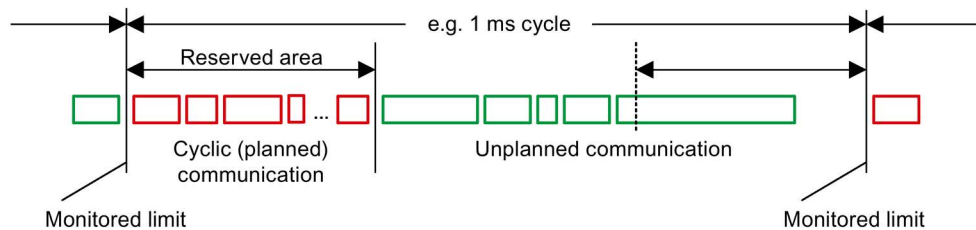

Figure 11-29 Bandwidth distribution/reservation, PROFINET IO

11.3.1.2 Addresses

MAC address

Every Ethernet and therefore every PROFINET interface is assigned a worldwide unique device identifier in the factory. This 6-byte long device identifier is the MAC address. The MAC address is divided up as follows:

- Three bytes for the manufacturer's ID
- Three bytes for the device identifier (consecutive number)

The MAC address is printed on a label (CBE20) or specified on the type plate (CU320-2 PN and CU310-2 PN), e.g.: 08-00-06-6B-80-C0.

The Control Units CU320-2 PN and CU310-2 PN have two integrated interfaces:

- One Ethernet interface
- One PROFINET interface with two ports

The two MAC addresses of the Ethernet and PROFINET interfaces are on the type plate.

IP address

The TCP/IP protocol is a prerequisite for establishing a connection and parameterization. To allow a PROFINET device to be addressed as a node on Industrial Ethernet, this device requires a unique IP address in the network. The IP address is made up of 4 decimal numbers with a range of values from 0 through 255. The decimal numbers are separated by a decimal point. The IP address comprises:

- The address of the node (also called host or network node)
- The address of the (sub) network

IP address assignment

The IP addresses of IO devices can be assigned by the IO controller and always have the same subnet mask as the IO controller. In this case, the IP address is not stored permanently. The IP address entry is lost after POWER ON/OFF. The IP address can be assigned retentively via the STARTER function "Accessible nodes" (see SINAMICS S120 Commissioning Manual).

This function can also be performed with HW Config of STEP 7. The function is called "Edit Ethernet node" here.

Note

IP addresses of the onboard interfaces

It is not permissible that the IP address band of the Ethernet interface and the PROFINET interface are the same. The factory setting of the IP address of the Ethernet interface X127 is 169.254.11.22; the subnet mask is 255.255.0.0.

Ethernet interface X127 is intended for commissioning and diagnostics.

Do not use this interface for other purposes and ensure that X127 (e.g. for service) is always accessible.

Note

If the network is part of an existing Ethernet company network, obtain the information (IP address) from your network administrator.

Device name (NameOfStation)

When it is shipped, an IO device does not have a device name. An IO device can only be addressed by an IO controller, for example, for the transfer of project engineering data (including the IP address) during startup or for user data exchange in cyclic operation, after it has been assigned a device name with the IO supervisor.

Note

The device name must be stored retentively using either STARTER or with the hardware Config of STEP 7.

Note

You can enter the address data for the internal PROFINET ports X150 P1 and P2 in STARTER in the expert list using parameters p8920, p8921, p8922 and p8923.

You can enter the address data for the ports of the optional CBE20 module in STARTER in the expert list using parameters p8940, p8941, p8942 and p8943.

Replacing the CU320-2 DP/PN and CU310-2 PN Control Units (IO device)

If the IP address and device name are stored in non-volatile memory, this data is also forwarded with the memory card of the Control Unit. The memory card allows module exchange without an IO supervisor when a fault occurs in a PROFINET device.

If a complete Control Unit needs to be replaced due to a device or module defect, the new Control Unit automatically parameterizes and configures using the data on the memory card. Following this, cyclic exchange of user data is restarted.

11.3.1.3 Data transfer

Properties

The PROFINET interface on a drive unit supports the simultaneous operation of:

- IRT – Isochronous Real Time Ethernet
- RT – Real Time Ethernet
- Standard Ethernet services (TCP/IP, LLDP, UDP and DCP)

PROFIdrive telegram for cyclic data transmission, acyclic services

Telegrams to send and receive process data are available for each drive object of a drive unit with cyclic process data exchange.

In addition to cyclic data transfer, acyclic services can also be used for parameterizing and configuring the drive unit. These acyclic services can be utilized by the IO supervisor or IO controller.

Sequence of drive objects in the telegram

On the drive side, the sequence of drive objects in the telegram is displayed via a list in p0978[0...24] where it can also be changed.

You can use the STARTER commissioning tool to display the sequence of drive objects for a commissioned drive system in the project navigator under "Drive unit" > "Communication" > "Telegram configuration".

When you create the configuration on the controller side (e.g. HW Config), the process-data-capable drive objects for the application are added to the telegram in the shown sequence (see above).

The following drive objects can exchange process data:

- Active Infeed (A_INF)
- Basic Infeed (B_INF)
- Control Unit (CU_S)
- ENC
- Smart Infeed (S_INF)
- SERVO
- Terminal Board 30 (TB30)
- Terminal Module 15 (TM15)
- Terminal Module 31 (TM31)
- Terminal Module 41 (TM41)
- Terminal Module 120 (TM120)
- Terminal Module 150 (TM150)
- VECTOR

Note

The sequence of drive objects in HW Config must be the same as that in the drive (p0978).
Drive objects after the first zero in p0978 must not be configured in the HW Config.

The structure of the telegram depends on the drive objects taken into account during configuration. Configurations are permitted that do not take into account all of the drive objects that are present in the drive system.

Example:

The following configurations, for example, are possible:

- Configuration with SERVO, SERVO, SERVO
- Configuration with A_INF, SERVO, SERVO, SERVO, TB30
- etc.

11.3.1.4 Communication channels for PROFINET

PROFINET connection channels

- A Control Unit has an integrated Ethernet interface (X127).
- The PROFINET versions CU320-2 PN and CU310-2 PN each have a PROFINET interface (X150) with two onboard ports: P1 and P2
- A CU320-2 PN or a CU310-2 PN Control Unit can simultaneously establish a total of eight acyclic connections (e.g. S7) via the integrated PROFINET interfaces.

Control Unit with CBE20

A Communication Board can be optionally inserted in the CU320-2 PN/DP Control Unit:

- The CBE20 Communication Board is a PROFINET switch with four additional PROFINET ports.

Note

PROFINET routing

Routing is neither possible between the onboard interfaces X127 and X150 – nor between the onboard interfaces of the Control Unit 320-2 PN and an inserted CBE20.

Overview of important parameters (see SINAMICS S120/S150 List Manual)

Integrated PROFINET interface

- p8920[0...239] PN name of station
- p8921[0...3] PN IP address
- p8922[0...3] PN default gateway
- p8923[0...3] PN Subnet Mask
- p8924 PN DHCP mode
- p8925 PN interfaces configuration
- p8929 PN number of remote controllers
- r8930[0...239] PN Name of Station actual
- r8931[0...3] PN IP Address actual
- r8932[0...3] PN Default Gateway actual
- r8933[0...3] PN Subnet Mask actual
- r8935[0...5] PN MAC Address
- r8936[0...1] PN state of the cyclic connections
- r8937[0...5] PN diagnostics
- r61000[0...239] PROFINET name of station
- r61001[0...3] PROFINET IP of station

CBE20

- p8829 CBE2x number of remote controllers
- p8940[0...239] CBE2x name of station
- p8941[0...3] CBE2x IP Address
- p8942[0...3] CBE2x Default Gateway
- p8943[0...3] CBE2x Subnet Mask
- p8944 CBE2x DHCP mode
- p8945 CBE2x interfaces configuration
- r8950[0...239] CBE2x Name of Station actual
- r8951[0...3] CBE2x IP address actual
- r8952[0...3] CBE2x Default Gateway actual
- r8953[0...3] CBE2x Subnet Mask actual
- r8954 CBE2x DHCP Mode actual
- r8955[0...5] CBE2x MAC address
- r8959 CBE2x DAP ID
- r61000[0...239] PROFINET name of station
- r61001[0...3] PROFINET IP of station

11.3.2 Drive control with PROFINET

PROFINET interfaces for CU310-2 PN, CU320-2 DP and CU320-2 PN

The CU310-2 PN and CU320-2 PN Control Units have an integrated PROFINET interface with two ports.

The CBE20 option board can be additionally inserted in the option slot of a CU320-2 DP or CU320-2 PN. The CBE20 is a PROFINET switch with four ports.

Note

PROFINET interfaces on the CU320-2 PN with CBE20

The integrated PROFINET interface of the CU320-2 PN is independent of the optionally inserted CBE20 module. The two PROFINET interfaces are not connected with each other. Routing is not possible between the two PROFINET interfaces.

Note

Ring topology

When connecting the ports, it must be ensured that for standard applications a ring topology is not created. Additional information on ring topologies can be found in Section Media redundancy (Page 785).

References

- The integration of a SINAMICS S120 with CU310-2 PN/CU320-2 DP/CU320-2 PN in a PROFINET IO system is described in detail in the "SIMOTION SCOUT Communication" System Manual.
- For an example of how to link a Control Unit to a SIMATIC S7 via PROFINET IO, please refer to the FAQ in the Online Support "PROFINET IO communication between an S7-CPU and SINAMICS S120 (<http://support.automation.siemens.com/WW/view/en/27196655>)".
- For a description of the CBE20 and how you can use it in the drive, please refer to the SINAMICS S120 Control Units and Additional System Components Manual.
- The PROFINET interface on the CU310-2 PN unit is described in the SINAMICS S120 AC Drive Manual:

Clock generation via PROFINET IO (isochronous communication)

SINAMICS S120 with CU310-2 PN/CU320-2 DP/CU320-2 PN can only assume the role of a synchronization slave within a PROFINET IO network.

For a CU310-2 PN/CU320-2 DP/CU320-2 PN with CBE20 module, the following applies:

- Transmission type IRT, IO device is synchronization slave and isochronous, send cycle is applied to bus: Control Unit synchronizes with the bus and the send cycle becomes the cycle for the Control Unit.
- RT or IRT (option drive unit "not isochronous") has been configured. SINAMICS uses the local cycle configured in SINAMICS.

The following applies to a CU320-2 DP/CU320-2 PN for which a CBE20 is configured, but does not exist:

- SINAMICS uses the local clock (clock configured in SINAMICS); if there is no data exchange via PROFINET, alarm A01487 is output ("Topology: Comparison option slot components missing in the actual topology"). Access via PROFINET is not available.

Telegrams

PROFIdrive telegrams are available for implementing cyclic communication via PROFINET IO (see Section "Communication according to PROFIdrive", Cyclic communication (Page 704)).

DCP flashing

This function is used to check the correct assignment to a module and its interfaces. This function is supported by a CU310-2 PN and a CU320-2 DP/PN with inserted CBE20. The function can also be used without CBE20 in a CU320-2 PN.

1. In HW Config or the STEP 7 Manager, select the menu item "Target system" > Ethernet > Edit Ethernet node".

The "Edit Ethernet Node" dialog box opens.

2. Click the "Browse" button.

The "Browse Network" dialog box opens and displays the connected nodes.

3. Select the CU310-2 PN or the CU320-2-DP with inserted CBE20 as node.

The "DCP flashing" function is then activated via the "Flash" button.

The DCP flashing will be effective on the RDY LED (READY LED 2 Hz, green/orange or red/orange) on the CU310-2 PN/CU320-2 DP.

The LED will continue to flash as long as the dialog is open. When the dialog is closed, the LED will go out automatically. The function is available as of STEP 7 V5.3 SP1 via Ethernet or via STARTER.

STEP 7 routing with CBE20

The CBE20 does not support STEP 7 routing between PROFIBUS and PROFINET IO.

Connecting a PG/PC with the STARTER commissioning tool

To commission a Control Unit with a PG/PC using the STARTER commissioning tool, there are the connection options PROFIBUS, PROFINET or Ethernet.

Note

Ethernet interface X127 is intended for commissioning and diagnostics. Do not use this interface for other purposes (e.g. field bus communication) and ensure that X127 (e.g. for service) is always accessible.

The IP address of the Ethernet interface is set permanently to 169.254.11.22. You require a crosslink cable to establish a direct connection between the PG/PC and the Control Unit (an Ethernet cable is often sufficient for modern PCs).
Communication with the controller can be established via PROFIBUS or PROFINET, depending on the selected integrated interfaces. Examples of possible topologies are provided in the diagram below:

Topology1
Commissioning via Ethernet (ET), device via internal PROFINET to the controller

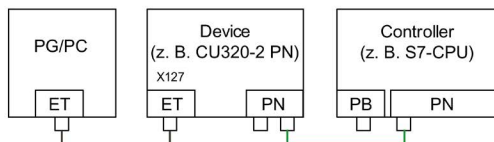

Topology2
Commissioning via ET, device via CBE20 PROFINET to the controller

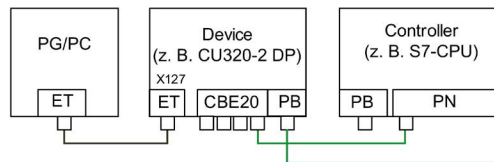

Topology3
Commissioning via ET, device via internal PROFINET to the controller

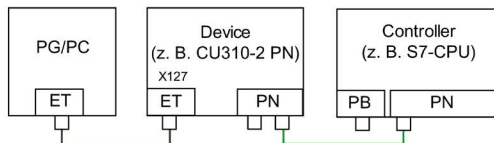

Topology4
Commissioning via ET, device via internal PROFIBUS to the controller

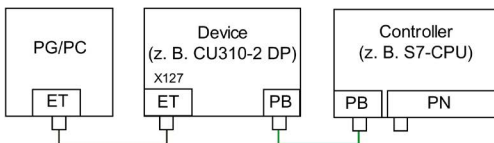

Figure 11-30 Topology Ethernet/PROFINET with PG/PC

Note

Routing is not possible between the two interfaces.

11.3.2.1 Media redundancy

To increase the availability of PROFINET, you can create a ring topology. If the ring is interrupted at one point, the data paths between the devices are automatically reconfigured. Following reconfiguration, the devices can once again be accessed in the resulting new topology.

To create a ring topology with media redundancy, route the two ends of a line-type PROFINET topology to a switch which serves as redundancy manager (e.g. a suitable SCALANCE switch). Closing the linear bus topology is realized using two ports (ring ports) of the SCALANCE redundancy manager, which monitors the data telegrams in the PROFINET ring. All other connected PROFINET nodes are redundancy clients.

The Media Redundancy Protocol (MRP) is the standard procedure for media redundancy. Using this procedure, a maximum of 50 devices can participate in each ring. In the case of an interrupted cable, data transfer is only briefly interrupted as the system switches over to the redundant data path.

If a short-term interruption is not permitted, data transfer must be set to IRT High Performance. The uninterruptible MRRT is automatically set. A SIMOTION controller (or another suitable controller) is required in this case.

The two integrated PROFINET IO interfaces of the Control Units CU320-2 PN and CU310-2 PN can be configured as redundancy clients.

From a CBE20, only the first two ports are capable of establishing a ring topology. Routing between the integrated PROFINET IO interfaces and a CBE20 is not possible.

11.3.3 RT classes for PROFINET IO

PROFINET IO is a scalable realtime communication system based on Ethernet technology. The scalable approach is expressed with three realtime classes.

RT

RT communication is based on standard Ethernet. The data is transferred via prioritized Ethernet telegrams. Because standard Ethernet does not support any synchronization mechanisms, isochronous operation is not possible with PROFINET IO with RT!

The real update cycle in which cyclic data is exchanged depends on the bus load, the devices used and the quantity framework of the I/O data. The update cycle is a multiple of the send cycle.

IRT

Two options are available with this RT class:

- IRT "high flexibility"
- IRT "high performance"

The real-time classes IRT "high flexibility" and IRT "high performance" can be selected as options in the synchronization settings configuration area of HW Config. In the description below, both these classes are simply referred to as "IRT".

Software preconditions for configuring IRT:

- STEP 7 5.4 SP4 (HW Config)

Note

For further information about configuring the PROFINET interface for the I/O controller and I/O device, please refer to the following document: SIMOTION SCOUT Communication System Manual.

IRT "high flexibility"

The telegrams are sent cyclically in a deterministic cycle (Isochronous Real Time). The telegrams are exchanged in a bandwidth reserved by the hardware. One IRT time interval and one standard Ethernet time interval are created for each cycle.

Note

IRT "high flexibility" cannot be used for isochronous applications.

IRT "high performance"

In addition to the bandwidth reservation, the telegram traffic can be further tuned by configuring the topology. This enhances the performance during data exchange and the deterministic behavior. The IRT time interval can thus be further tuned or minimized with respect to IRT "high flexibility".

In addition to the isochronous data transfer provided by IRT, even the application itself (position control cycle, IPO cycle) can be isochronous in the devices. This is an essential requirement for closed-loop axis control and synchronization via the bus. Isochronous data transfer with cycle times well below one millisecond and with a deviation in the cycle start (jitter) of less than a microsecond provide sufficient performance reserves for demanding motion control applications.

In contrast to standard Ethernet and PROFINET IO with RT, the telegrams for PROFINET IO with IRT are transferred according to a schedule.

Modules

The following S110/S120 modules support the IRT "high performance":

- S120 CU320 together with the CBE20
- S120 CU320-2 DP together with the CBE20
- S120 CU320-2 PN
- S120 CU310 PN
- S120 CU310-2 PN
- S110 CU305 PN

Comparison between RT and IRT

Table 11- 12 Comparison between RT and IRT

	RT	IRT "high flexibility"	IRT "high performance"
Transfer mode	Switching based on the MAC address; prioritization of the RT telegrams possible using Ethernet-Prio (VLAN tag).	Switching using the MAC address; bandwidth reservation by reserving an IRT "high flexibility" interval in which only IRT "high flexibility" frames are transferred but, for example, no TCP/IP frames.	Path-based switching according to a topology-based plan; no transmission of TCP/IP frames and IRT "high flexibility" frames in the IRT "high performance" interval.
Isochronous application in the IO controller	No	No	Yes
Determinism	Variance of the transmission duration by started TCP/IP telegrams.	Guaranteed transmission of the IRT "high flexibility" telegrams in the current cycle by the reserved bandwidth.	Exactly planned transfer; times for transmission and receiving are guaranteed for any topologies.
Reload the network configuration after a change	Not relevant	Only when the size of the IRT "high flexibility" interval needs to be modified (reservation of position is possible).	Always when the topology or the communications relationships change.
Maximum switching depth (number of switches in one line)	10 at 1 ms	61	64
For possible send cycles, see subitem "Send cycles and update cycles for RT classes" in table "Adjustable send cycles and update cycles"			

Set the RT class

The RT class is set by means of the properties of the controller interface of the IO controller. If RT class IRT "high performance" is set, it is not possible to operate any IRT "high flexibility" devices on the IO controller and vice versa. IO devices with RT can always be operated, regardless of the IRT class setting.

You can set the RT class in the HW Config for the associated PROFINET device.

1. In HW Config, double-click item PROFINET interface in the module.

The "Properties" dialog box opens.

2. Select the RT class under RT class on the "Synchronization" tab.
3. Once you have selected "IRT", you can also choose between option "high flexibility" and "high performance".
4. Confirm with "OK".

Synchronization domain

The sum of all devices to be synchronized form a synchronization domain. The whole domain must be set to a single, specific RT class (real-time class) for synchronization. Different synchronization domains can communicate with one another via RT.

For IRT, all IO devices and IO controllers must be synchronized with a common synchronization master.

RT allows an IO controller to communicate with a drive unit outside a synchronization domain or "through" another synchronization domain. As of version 5.4 SP1, STEP 7 supports multiple synchronization domains on a single Ethernet subnet.

Example:

- Synchronization domain IRT: SIMOTION2 with SINAMICS
- SINAMICS drive that is assigned to the I/O system of SIMOTION1. This is arranged in the topology in such a way that its RT communication must be established through the IRT synchronization domain.

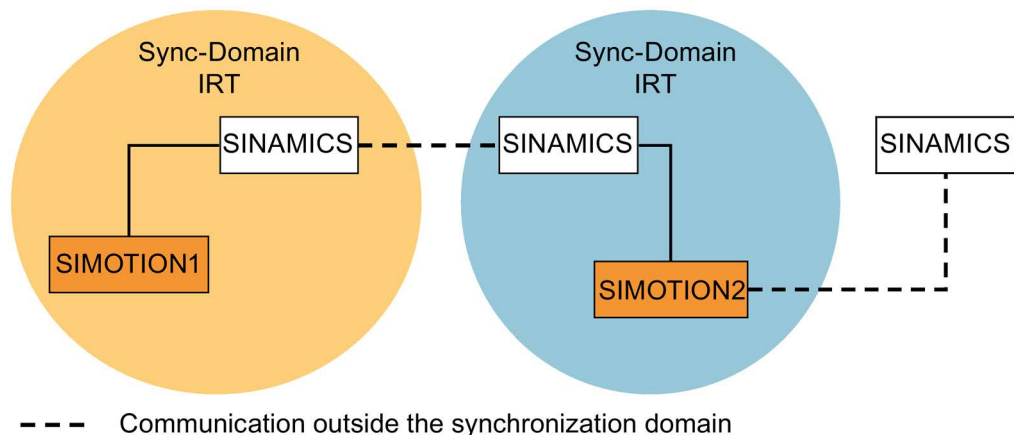

Figure 11-31 RT communication across the limits of synchronization domains

Update cycles and send cycles for RT classes

Definition of the update time / send cycle:

If we take a single IO device in the PROFINET IO system as an example, this device has been supplied with new data (outputs) by the IO controller and has transferred new data (inputs) to the IO controller within the update time. The send cycle is the shortest possible update cycle.

All cyclic data is transferred within the send cycle. The actual send cycle that can be set depends on various factors:

- Bus load
- Type of devices used
- Computing capacity available in the IO controller
- Supported send clocks in the participating PROFINET devices of a synchronization domain. A typical send cycle is 1 ms.

The table below specifies the reduction ratios which can be set between the send cycle and the update times for IRT "high performance", IRT "high flexibility", and RT.

Table 11- 13 Settable send cycles and update cycles

Send cycle		Reduction ratio between update and send cycles	
		RT IRT "high flexibility" ⁴⁾	IRT "high performance"
Range "even" ¹⁾	250, 500, 1000 µs	1, 2, 4, 8, 16, 32, 64, 128, 256, 512	1, 2, 4, 8, 16 ²⁾
	2000 µs	1, 2, 4, 8, 16, 32, 64, 128, 256	1, 2, 4, 8, 16 ²⁾
	4000 µs	1, 2, 4, 8, 16, 32, 64, 128	1, 2, 4, 8, 16 ²⁾
Range "odd" ³⁾	375, 625, 750, 875, 1125, 1250 µs ... 3875 µs (increment 125 µs)	Not supported ⁵⁾	1

Explanations for the above table:

- 1) It is only possible to set send cycles from the "even" range when IO devices with real-time class "RT" are assigned to a synchronization domain. Likewise, only the reduction ratios from the "even" range can be set for a send cycle setting from the "even" range.
- 2) It is generally only possible to set a reduction ratio of 1:1 between the update time and send cycle for IO devices (ET200S IM151-3 PN HS, SINAMICS S) which are operated in isochronous mode. In this case, the update cycle mode must always be set to "fixed factor" (under IO device properties, "IO cycle" tab, "Mode" pulldown menu). This means that STEP 7 will not automatically adjust the update cycle and thus the update cycle will always correspond to the send cycle.
- 3) The send cycles from the "odd" range can be set only if a synchronization domain does not include any IO devices with real-time class "RT". Likewise, only the reduction ratios from the "odd" range can be set for a send cycle setting from the "odd" range.
- 4) Isochronous operation is not compatible with IRT "high flexibility".
- 5) Odd send cycles can be used only if the IO systems assigned to the synchronization domain do not include any RT or IRT "high flexibility" devices.

Furthermore, the send cycles which can actually be set are determined by the intersection of the send cycles supported by all the devices in the synchronization domain.

The reduction ratio between the update cycle of an IO device and the send cycle is set in the "Properties" of the PROFINET interface for the relevant device.

Note

There is no intersection between the send cycles for the "even" and "odd" ranges!

Send cycles for SINAMICS drive units

A SINAMICS drive unit with PROFINET interface which supports IRT permits send cycle settings of between 0.25 ms and 4.0 ms in a 250 μ s time frame.

Topology rules**Topology rules for RT**

- A topology can be, but need not be configured for RT. If a topology has been configured, the devices must be wired in accordance with the topology.
- Otherwise, the wiring between devices is entirely optional.

Topology rules for IRT

- Mixed operation is not supported by STEP 7 V5.4 SP4, i.e. IRT "high performance" cannot be combined with IRT "high flexibility" in the same synchronization domain.
- A synchronization domain with IRT "high performance" can contain a maximum of one IRT "high performance" island. "Island" means that the devices must be interconnected to match the configured topology. A synchronization master must be positioned in the relevant island.
- IRT "high flexibility" is subject to the same topology rules as for IRT "high performance", the only exception being that a topology does not need to be configured. However, if a topology has been configured, the devices must be wired to match the topology.

Device selection in HW Config**Hardware catalog:**

The drive unit from the appropriate device family entry in the hardware catalog must be configured. For the real-time class IRT, these are all entries as of firmware version V2.5.

GSDML:

GSDML files for devices which contain IRT as of firmware version V2.5.

11.3.4 PROFINET GSDML

SINAMICS S120 supports the GSDML version: "PROFINET GSDML with subslot configuration" to embed the converter in a PROFINET network.

PROFINET GSDML with subslot configuring

PROFINET GSDML with subslot configuring allows standard telegrams to be combined with a PROFIsafe telegram - and if required, a telegram extension. Each of the modules has four subslots: The Module Access Point (MAP), the PROFIsafe telegram, a PZD telegram to transfer process data and where necessary, a telegram for PZD extensions. Example:

GSDML-V2.31-Siemens-Sinamics_S_CU3x0_20160101.xml

You can download GSDML files from the following Siemens Internet address:

PROFINET GSDML (<https://support.industry.siemens.com/cs/ww/en/view/49217480>)

The following table shows the possible submodules depending on the particular drive object.

Table 11- 14 Submodules depending on the particular drive object

Module	Subslot 1 MAP	Subslot 2 PROFIsafe	Subslot 3 PZD telegram	Subslot 4 PZD extension	Max. number of PZD
SERVO	MAP	Telegram 30/31/901/902	Telegrams: 1...220 free PZD-16/16	PZD-2/2, -2/4, -2/6	20/28
VECTOR	MAP	Telegram 30/31/901/902	Telegrams: 1...352 free PZD-16/16, 32/32	PZD-2/2, -2/4, -2/6	32/32
Infeed	MAP	Reserved	Telegrams: 370, 371 free PZD-4/4	PZD-2/2, -2/4, -2/6	10/10
Encoder	MAP	Reserved	Telegrams: 81, 82, 83 free PZD-4/4	PZD-2/2, -2/4, -2/6	4/12
TB30, TM31, TM15 DI_DO, TM120	MAP	Reserved	Telegrams: no free PZD-4/4	Reserved	5/5
TM150	MAP	Reserved	Telegrams: no free PZD-4/4	Reserved	7/7
TM41	MAP	Reserved	Telegrams: 3 free PZD-4/4, 16/16	Reserved	20/28
Control Unit	MAP	Reserved	Telegrams: 390, 391, 392, 393, 394, 395 free PZD-4/4	Reserved	5/21
TM15/TM17	Not supported.				

The telegrams in subslots 2, 3 and 4 can be freely configured, i.e. they can also remain empty.

Configuration

Configuring the three versions is only briefly sketched out in the following:

Compact modules (as before):

1. Insert a "DO SERVO/VECTOR/..." module.
2. Assign the I/O addresses.

Subslot configuring without new functionality:

1. Insert a module "DO with telegram xyz".
2. Insert a submodule "PZD telegram xyz".
3. Assign the I/O addresses.

Subslot configuring with optional PROFIsafe and PZD extension:

1. Insert a "DO SERVO/VECTOR/..." module.
2. Insert the optional submodule "PROFIsafe telegram 30".
3. Insert a submodule "PZD telegram xyz".
4. Insert the optional submodule "PZD extension".
5. Assign the I/O addresses for the module and the submodules.

You will find a detailed description for processing a GSDML file in HW Config in the SIMATIC documentation.

11.3.5 Motion Control with PROFINET

Motion Control / isochronous drive link with PROFINET

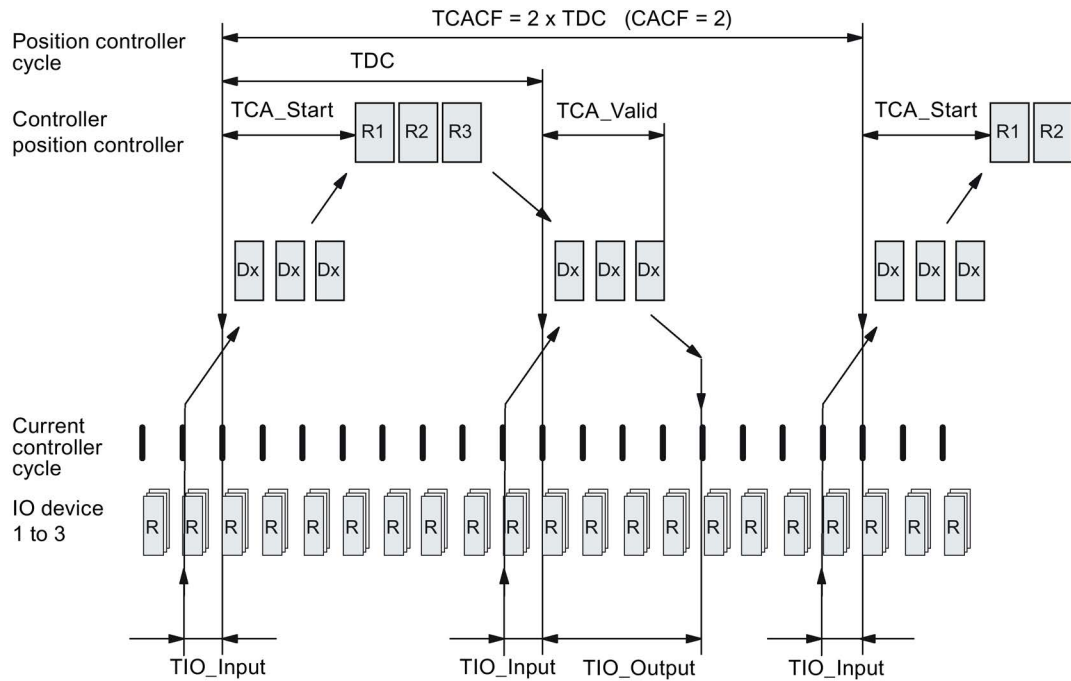

Figure 11-32 Motion Control / isochronous drive link with PROFINET, optimized cycle with CACF = 2 (Controller Application Cycle Factor)

Sequence of data transfer to closed-loop control system

1. Actual position value G1_XIST1 is read into the telegram image at time T_{IO_Input} before the start of each cycle and transferred to the master in the next cycle.
2. Closed-loop control on the master (Controller in the figure) starts at time T_{CA_Start} after each position controller cycle and uses the current actual values read previously from the slaves (Device in the figure).
3. In the next cycle, the master transfers the calculated setpoints to the telegram image of the slaves. The speed setpoint command NSET_B is issued to the closed-loop control system at time T_{IO_Output} after the beginning of the cycle.

Designations and descriptions for motion control

Table 11- 15 Time settings and meanings

Name	Limit value	Description
T _{DC_BASE}	-	Time basis for cycle time T _{DC} calculation: $T_{DC_BASE} = T_{DC_BASE} \times 31.25 \mu s = 4 \times 31.25 \mu s = 125 \mu s$
T _{DC}	$T_{DC_MIN} \leq T_{DC} \leq T_{DC_MAX}$	Cycle time $T_{DC} = T_{DC} \times T_{DC_BASE}$, T _{DC} : integer factor CBE20: $T_{DC_MIN} = T_{DC_MIN} \times T_{DC_BASE} = 4 \times 125 \mu s = 500 \mu s$ $T_{DC_MAX} = T_{DC_MAX} \times T_{DC_BASE} = 32 \times 125 \mu s = 4 \text{ ms}$ X150 (CU3x0-2 PN): $T_{DC_MIN} = T_{DC_MIN} \times T_{DC_BASE} = 2 \times 125 \mu s = 250 \mu s$ $T_{DC_MAX} = T_{DC_MAX} \times T_{DC_BASE} = 32 \times 125 \mu s = 4 \text{ ms}$
T _{CACF}	CACF = 1-14	IO controller application cycle time This is the time frame in which the IO controller application generates new setpoints (e.g. in the position controller cycle). Calculation example: $T_{CACF} = CACF \times T_{DC} = 2 \times 500 \mu s = 1 \text{ ms}$
T _{CA_Valid}	$T_{CA_Valid} < T_{DC}$	Time, measured from the beginning of the cycle, at which the actual values of all IO devices for the controller application process (position control) are available.
T _{CA_Start}	$T_{CA_Start} > T_{CA_Valid}$	Time, measured from the beginning of the cycle, at which the controller application process (position control) starts.
T _{IO_BASE}		Time base for T _{IO_Input} , T _{IO_Output} $T_{IO_BASE} = T_{IO_BASE} \times 1 \text{ ns} = 125000 \times 1 \text{ ns} = 125 \mu s$
T _{IO_Input}	$T_{IO_InputMIN} \leq T_{IO_Input} < T_{DC}$	Time of actual value acquisition This is the time at which actual values are acquired before a new cycle starts. $T_{IO_Input} = T_{IO_Input} \times T_{IO_BASE}$ T _{IO_Input} : integer factor
	T _{IO_InputMIN}	Minimum value for T _{IO_Input} Calculation: $T_{IO_InputMIN} = T_{IO_InputMIN} \times T_{IO_BASE} = 375 \mu s$
T _{IO_Output}	$T_{IO_Output_valid} + T_{IO_OutputMIN} \leq T_{IO_Output} < T_{DC}$	Time of setpoint transfer This is the time, calculated from the beginning of the cycle, at which the transferred setpoints (speed setpoint) are accepted by the closed-loop control system. $T_{IO_Output} = T_{IO_Output} \times T_{IO_BASE}$ T _{IO_Output} : integer factor
	T _{IO_OutputMIN}	Minimum value for T _{IO_Output} Calculation: $T_{IO_OutputMIN} = T_{IO_OutputMIN} \times T_{IO_BASE} = 250 \mu s$
	T _{IO_Output_valid}	The time after which the new control output data (setpoints) is available for the drive object.
Dx		Data_Exchange This service is used to implement user data exchange between the IO controller and IO device 1 - n.
R or Rx		Computation time, current or position controller

Setting criteria for times

- Cycle (T_{DC})
 - T_{DC} must be set to the same value for all bus nodes. T_{DC} is a multiple of SendClock.
 - $T_{DC} > T_{CA_Valid}$ and $T_{DC} \geq T_{IO_Output}$

T_{DC} is thus large enough to enable communication with all bus nodes.
- T_{IO_Input} and T_{IO_Output}
 - Setting the times in T_{IO_Input} and T_{IO_Output} to be as short as possible reduces the dead time in the position control loop.
 - $T_{IO_Output} > T_{CA_Valid} + T_{IO_Output_MIN}$
- Settings and tuning can be done via a tool (e.g. HW Config in SIMATIC S7).

User data integrity

User data integrity is verified in both transfer directions (IO controller \longleftrightarrow IO device) by a sign-of-life (4-bit counter).

The sign-of-life counters are incremented from 1 to 15 and then start again at 1.

- IO controller sign-of-life
 - STW2.12 ... STW2.15 are used as the IO controller sign-of-life.
 - The IO controller sign-of-life counter is incremented in each IO controller application cycle (T_{CACF}).
 - The number of sign-of-life errors tolerated can be set via p0925.
 - p0925 = 65535 deactivates sign-of-life monitoring on the IO device.
 - Monitoring

The IO controller sign-of-life is monitored on the IO device and any sign-of-life errors are evaluated accordingly.

The maximum number of tolerated IO controller sign-of-life errors in succession can be set via p0925.

If the number of tolerated sign-of-life errors set in p0925 is exceeded, the response is as follows:

 1. A fault (F01912) is output.
 2. The value "0" is output as the IO device sign-of-life.
 3. A new synchronization (at least 15 received correct signs-of-life in succession) with the IO controller sign-of-life is started.

One sign-of-life error can be reset with ten correct signs-of-life in succession.
- IO device sign-of-life
 - ZSW2.12 ... ZSW2.15 are used as the IO device sign-of-life.
 - The IO device sign-of-life counter is incremented in each DC cycle (T_{DC}).
 - Monitoring of the IO device sign-of-life can be implemented in the controller application.

11.3.6 Communication with CBE20

The CBE20 is a Communication Board that can be flexibly used and which can be operated with different communication profiles. Only one firmware of a communication profile can be loaded at any one time. The available firmware files are saved with the communication profiles in UFW files on the Control Unit memory card.

The required file is selected using parameter p8835. A POWER ON must be carried out after selecting the desired UFW file. During the subsequent system boot, the corresponding UFW file is loaded. The new selection then becomes active.

Table 11- 16 Functionality and selection in the pointer file

Functionality (p8835)	Pointer file content	Detailed information on this:
PROFINET device	1	-
PROFINET Gate	2	Section "Communication via PROFINET Gate (Page 798)"
SINAMICS Link	3	Section "Communication via SINAMICS Link (Page 863)"
EtherNet/IP	4	Section "Communication via EtherNet/IP (Page 848)"
Modbus TCP	5	Section "Communication via MODBUS TCP (Page 830)"
Customer-specific ¹⁾ from OEM directory	99	-

¹⁾ Path for the UFW file and folders on the memory card: /OEM/SINAMICS/CODE/CB/CBE20.UFW

Identification of the firmware version

Using parameter r8858, the loaded firmware version of the PROFINET interface can be identified uniquely.

Overview of important parameters (see SINAMICS S120/S150 List Manual)

- p8835 CBE20 firmware selection
- r8858[0...39] COMM BOARD read diagnostics channel

11.3.7 Communication via PROFINET Gate

The "PN GATE FOR SINAMICS" is a PROFINET solution for controller manufacturers or mechanical equipment manufacturers who wish to simply integrate an interface to a PROFINET network in their controllers. PROFINET communication is implemented via the standard Ethernet interface of the controller without the need for a communication module or an option module.

"PN GATE FOR SINAMICS" enables control devices with a standard Ethernet interface to be connected isochronously via PROFINET with IRT to SINAMICS S120 and motion control, robotics or CNC applications to be implemented with SINAMICS S120 drives. In addition to the SINAMICS S120, other PROFINET devices (drives, distributed I/O, etc.) can be connected.

Possible drive units:

- CU320-2 PN

The CBE20 in the CU320-2 PN of the SINAMICS S120 contains the "PN Gate" function (p8835 = 2). The PN Gate represents the controller in the sense of PROFINET. It covers a standard PROFINET network.

The CBE20 (port 4) is connected via the standard Ethernet interface of the machine control.

The controller supplies the PROFINET controller in the CBE20 with the content required for all the I/O data cyclically and in a compact form in one or more Ethernet telegrams. For this purpose, a driver (part of the PN Gate) is used on the controller for the communication with the CBE20.

The CBE20 then distributes the I/O data to each individual device in the PROFINET network with one telegram in each case - both IRT and RT telegrams.

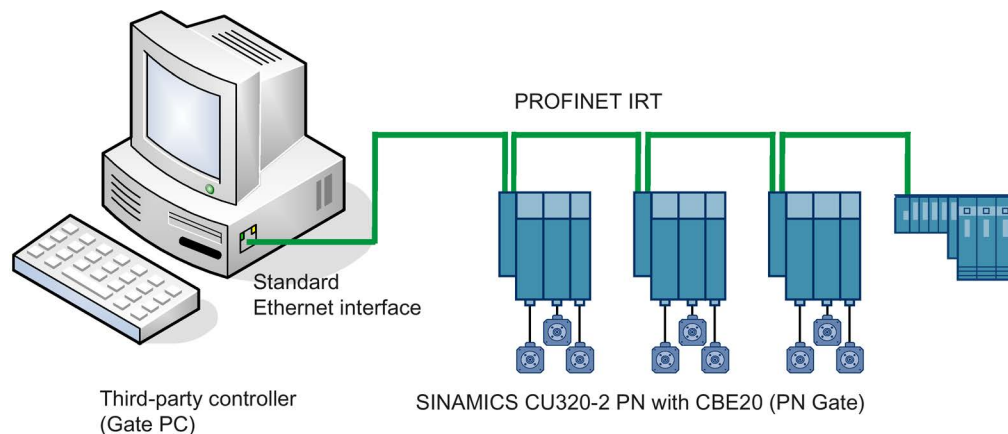

Figure 11-33 Schematic representation of SINAMICS PROFINET Gate (in short: PN Gate)

11.3.7.1 Functions supported by PN Gate

PN Gate function overview

Function	Description
Communication channels	<ul style="list-style-type: none"> • Cyclic data communication: <ul style="list-style-type: none"> – IRT – RT • Acyclic data communication: <ul style="list-style-type: none"> - PROFINET alarms - Read/write data set - TCP/IP
PROFINET basic services	<ul style="list-style-type: none"> • LLDP • DCP • SNMP
Accesses to process data	<p>Access to the process image:</p> <ul style="list-style-type: none"> • Subslot granular • Device granular
Consistency of the cyclic data	Each process data communication cycle can contain a data component for IRT and RT communication
Network topologies	<ul style="list-style-type: none"> • Line • Star • Tree
Information from the PN Gate	<ul style="list-style-type: none"> • Device number • Slot number with the associated subslot numbers • IO address • Diagnostic addresses • Module ID (vendor ID and module ID) • Send cycles and update times
Activating/deactivating	Activating and deactivating devices via the API without alarm triggering
Automatic address assignment	Topology-based initialization
Number of IO devices	A maximum of 64 devices
IO area in the controller	<ul style="list-style-type: none"> • 4096 bytes each, in and out • Maximum number of slots: 2048 • Maximum bytes per slot/module size: 254 bytes
Send cycle	<ul style="list-style-type: none"> • RT communication: 1 ms Update times RT 2^n with $n = 0$ to $9x$ send cycle • IRT communication 1 ms - 4 ms in increments of 250 μs minimum send cycle of 1 ms for 32 devices. It is permissible to reduce the data per device.

11.3.7.2 Preconditions for PN Gate

Hardware

- SINAMICS CU320-2 PN with firmware version as of 4.5
- Communication Board Ethernet 20 (CBE20)
- Short Ethernet cable to connect CBE20 and CU320-2 PN (X150)
Recommendation: Ethernet cable with the article number: 6SL3060-4AB00-0AA0
- Control hardware with standard Ethernet interface (100 Mbit/s or higher),
for example, the SIMATIC Box IPC 427C.

Note

The Gate PC must guarantee the short latency times required for operating the PN Gate. Influencing variables are the CPU performance, mainboard hardware (Ethernet chipset and its connection), and the BIOS and the software components involved (operating system components such as memory mapping, Ethernet driver, interrupt link, configuration).

Software

- STARTER as of V4.3
or
- Drive ES as of V5.5
or
- SIMATIC STEP 7 as of V5.5 SP2
- Development kit for the development and configuration:
 - SINAMICS PN Gate DevKit (Article No. 6SL3071-0CA00-0XA0)
- Licenses
 - The PN Gate CU requires a runtime license with Article No. 6SL3074-0AA03-0AA0 or the Z option G01 for CFC.

PROFINET version

- SINAMICS PN Gate V2 is compatible with PROFINET V2.2

Scope of delivery PN Gate Dev Kit (Development Kit)

The PN Gate development kit is supplied on a DVD and contains the following components:

- STEP 7 add-on setup
 - CD1
PN Gate add-on setup for STEP7 5.5 SP2, STARTER 4.3, SINAMICS 4.5
- PN Gate driver
 - Bin
Binary files of the driver in the Tar format.
 - Src
Source files as a zip file and unzipped.
 - Doc
Doxygen documentation as zip file. The Doxygen documentation is available in HTML and PDF format.
- Application example
 - PROFIdrive sample applications in binary and in source code.
- Documentation
 - German
PN Gate documentation in German.
 - English
PN Gate documentation in English.

You can find additional information in the "SINAMICS 120 PN Gate Configuration Manual".

11.3.8 PROFINET with 2 controllers

11.3.8.1 Control Unit settings

Note

Operation with two controllers is only possible in conjunction with an F-CPU.

SINAMICS S120 allows two control systems to be connected simultaneously to a Control Unit via PROFINET, e.g. an automation controller (A-CPU) and a safety controller (F-CPU).

SINAMICS S supports, for this communication, PROFIsafe standard telegrams 30 and 31, as well as Siemens telegrams 901 and 902 for the safety controller.

The following diagram shows the basic structure of this connection version, based on the example of a CU320-2 PN or CU310-2 PN.

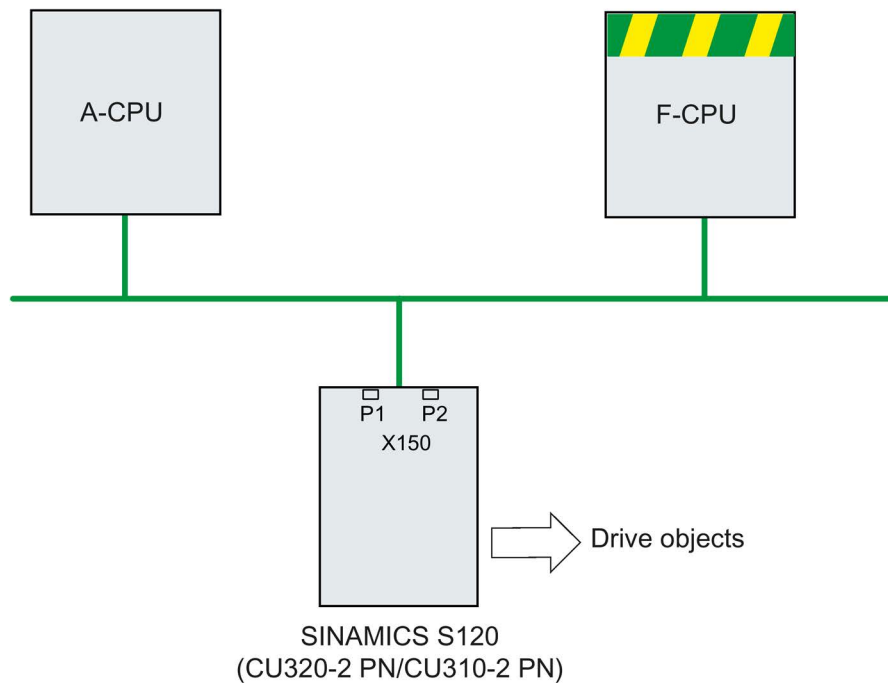

Figure 11-34 PROFINET topology overview

Example

The following diagram shows a configuration example of a drive with three axes. The A-CPU sends Siemens telegram 105 for axis 1 and Siemens telegram 102 for axis 2. The F-CPU sends PROFIsafe telegram 30 for axis 1 and axis 3.

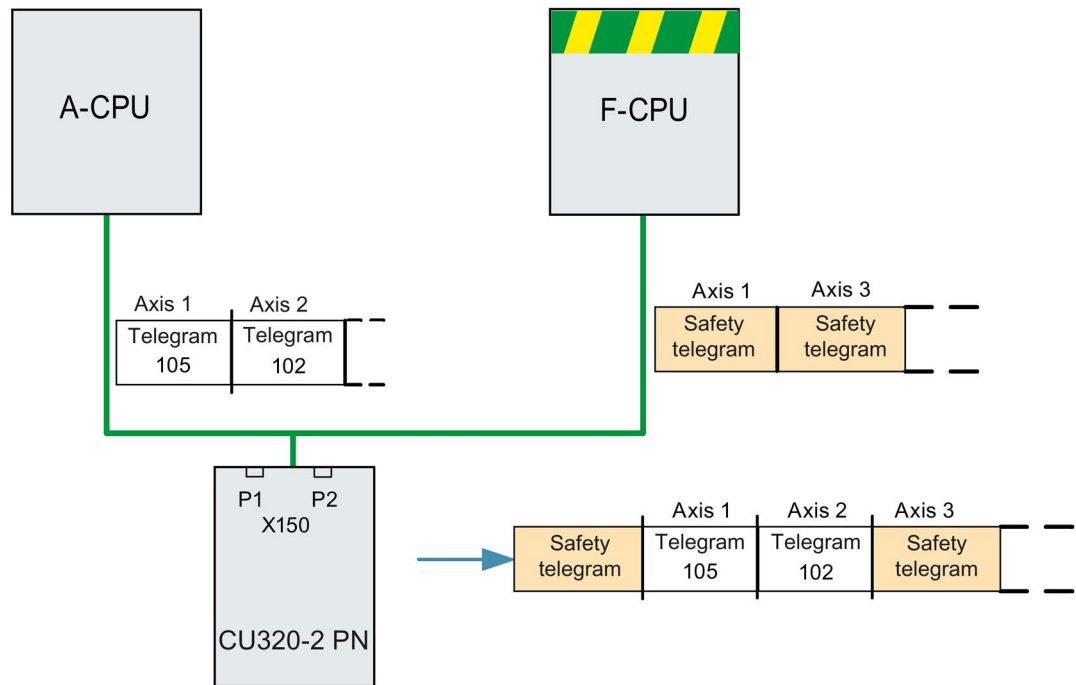

Figure 11-35 Example, communication sequence

Configuration

To configure the connection, proceed as follows:

1. Using parameter p8929 = 2, define that data from two control systems should be received via the PROFINET interface.
2. Using parameters p9601.3 = p9801.3 = 1, enable PROFIsafe for axes 1 and 2.
3. Configure the PROFINET communication in HW Config (see Section "Configuring the controllers").

When the system boots, using p8929 = 2, the drive system identifies that PROFINET telegrams are expected from two control systems, and establishes the communication corresponding to the configuration in HW Config.

Note

When booting, the drive system first requires the configuration data of A-CPU and then establishes a cyclic communication to this CPU taking into account the PROFIsafe telegrams expected.

As soon as the drive system has received the configuration data of the F-CPU, then cyclic communication is also established here and PROFIsafe telegrams are taken into consideration.

Note

CPU failure

Communication via the two channels functions independently of one another. In the event of failure of a CPU, communication with the other CPU is not interrupted, it continues to operate without interruption. Error messages are output regarding the components that have failed.

- Resolve the fault and acknowledge the messages. Communication to the CPU that failed is then automatically restored.

11.3.8.2 Configuring Shared Device

You have the following two options in **HW Config** when configuring the two controllers A-CPU and F-CPU:

- You configure both of the controllers using the Shared Device function in a common project.
- Using GDSML, you configure each controller independently in its own project.

The first of these options is described in the following example.

Note

Detailed information on configuring with **HW Config** is provided in the STEP 7 documentation.

Example: Two controllers in a common project

Start STEP 7:

1. Under S7, create a drive control for the new project, in the example called A-CPU, based on a SIMATIC 300.



Figure 11-36 Creating a new S7 project

2. In HW Config, select the CPU 315-2 PN/DP controller and connect the PROFINET IO as the communication network. Select an S120 as drive control (in the example a CU320-2 PN).

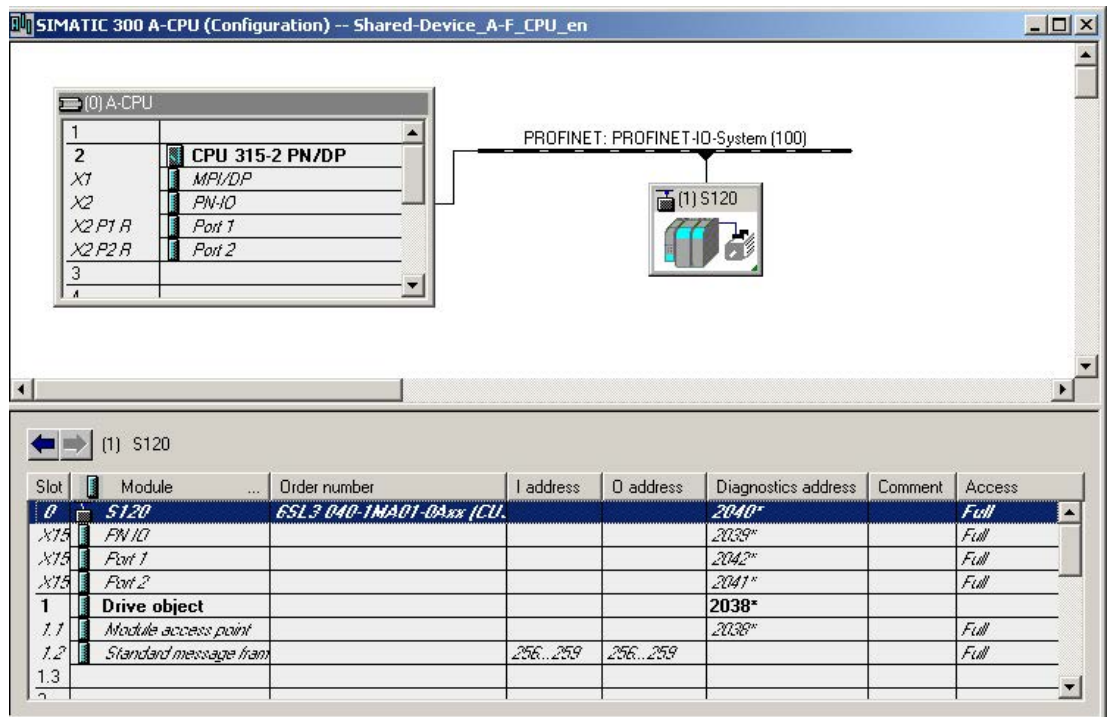

Figure 11-37 Drive control created in HW Config

3. Select menu "Station/save and compile" (Ctrl+S).
The previous project is saved.
4. To configure the drives in STARTER, from the shortcut menu of the S120 drive, select "Open object with STARTER".

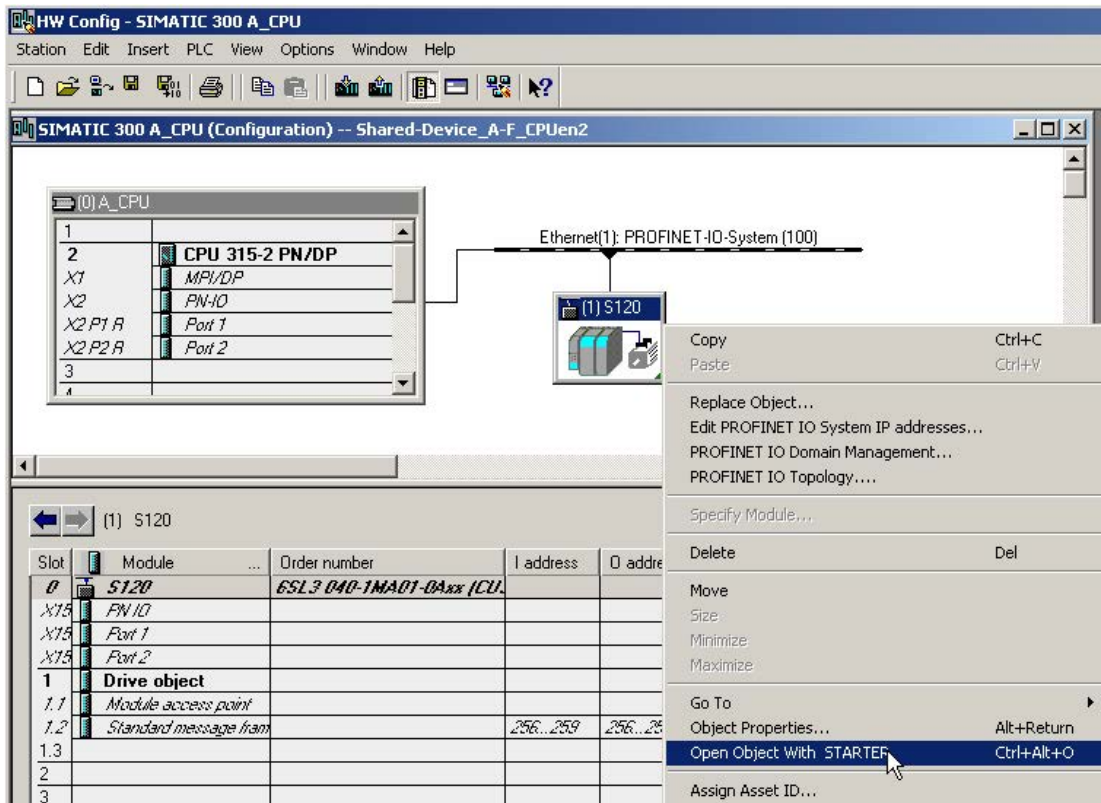

Figure 11-38 New project transferred from HW Config into STARTER

The STARTER window opens automatically

The project is displayed in the navigation window.

1. In the expert list of the Control Unit, set parameter p8929 = 2.

285	p8922[0]	PN Default Gateway of Station	0	Operation	3	0	255
286	p8923[0]	PN Subnet Mask of Station	0	Operation	3	0	255
287	p8925	PN interface configuration	[0] No function	Operation	3		
288	p8929	PN remote controller number	[2] Automation and Safety	Commissionin...	3		
289	p8930[0]	PN Name of Station active			3		
290	p8931[0]	PN IP Address of Station active	0		3		
291	p8932[0]	PN Default Gateway of Station active	0		3		

Figure 11-39 p8929 from the expert list of the Control Unit

2. Configure an infeed and three drives in servo control. We have selected telegram 370 for the infeed communication, and standard telegrams 1, 2 and 3 for the drives.

- Then click under project "Save and recompile all".
- Click in the navigation window "Communication \ Telegram Configuration".

Object	Drive object	-No.	Assigned controller	Message frame type	Input data		Output data	
					Length	Address	Length	Address
1	Supply_1	2		SIEMENS telegram 370, PZD-1/1	1	???.???	1	???.???
2	Drive_1	3		Standard telegram 1, PZD-2/2	2	???.???	2	???.???
3	Drive_2	4		Standard telegram 2, PZD-4/4	4	???.???	4	???.???
4	Drive_3	5		Standard telegram 3, PZD-5/9	9	???.???	5	???.???
5	Control_Unit	1	PN-IO	Free telegram configuration with BICO	2	256..259	2	256..259

Without PZDs (no cyclic data exchange)

Figure 11-40 Telegram overview for PROFIdrive channel IF1

3. Under ".....", add the safety telegrams 30 for the 1st and 3rd drive:

- In the table, click the drive that you want to monitor with PROFIsafe.
- Click the "Adapt telegram configuration" button and select "Add PROFIsafe".

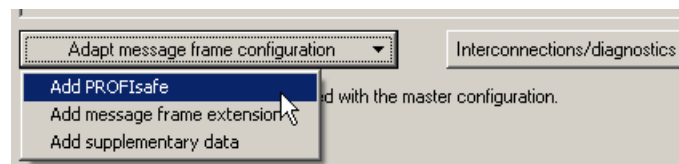

Figure 11-41 Add the PROFIsafe telegram to the drive

The PROFIsafe telegrams were added to the PROFIdrive table:

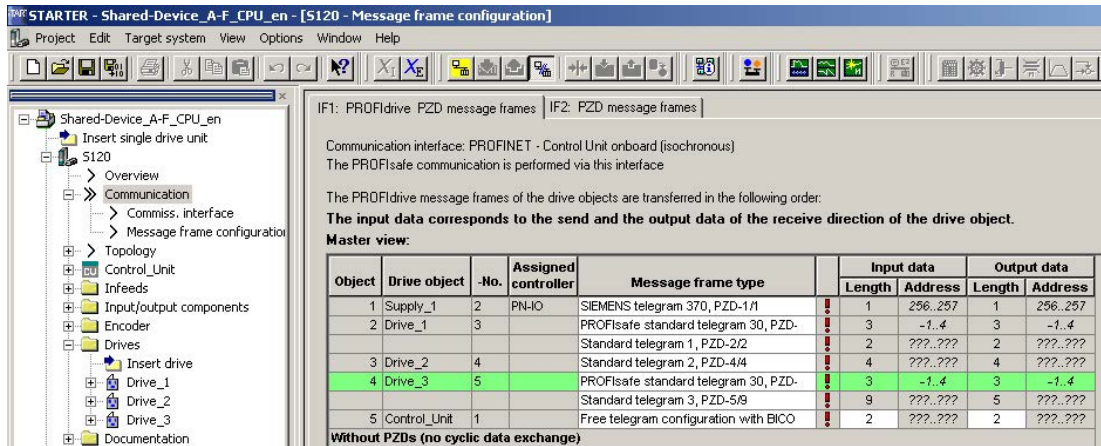

Figure 11-42 List of telegrams that are available

4. To transfer your telegram changes into HW Config, click on "Set up addresses".

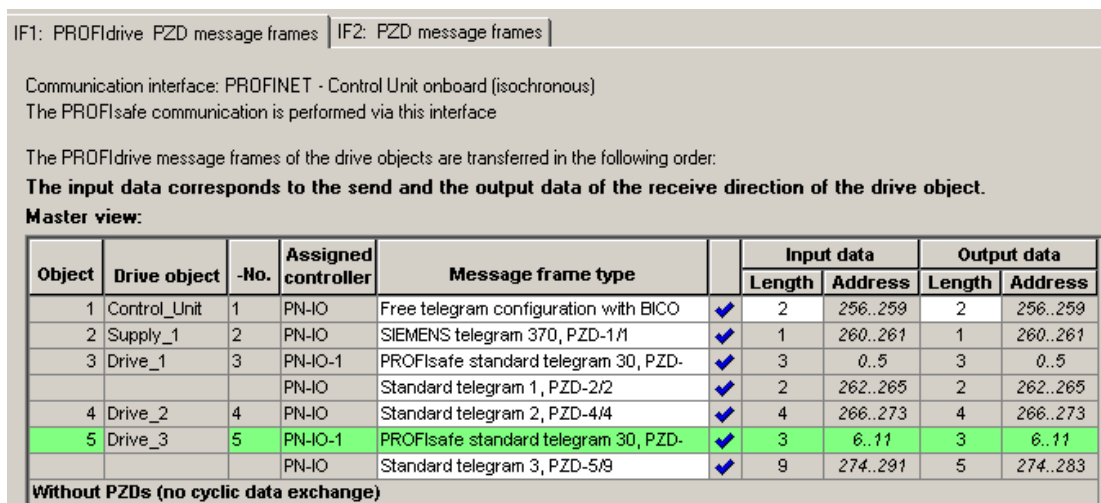

Figure 11-43 The telegrams were aligned with HW Config

After the telegrams have been successfully transferred to HW Config, the red exclamation mark is replaced by a checkmark.

Configuring the safety controller:

1. In the HW Config window click on the S120 component.

The screenshot shows the SIMATIC HW Config interface. The top window displays the configuration for a SIMATIC 300 A-CPU, including a CPU 315-2 PN/DP and various I/O modules. A PROFINET network is shown connecting the CPU to an S120 safety controller. The bottom window provides a detailed view of the S120 module, listing its slots, modules, order numbers, addresses, and access permissions.

Slot	Module	Order number	I address	Q address	Diagnostics address	Comment	Access
0	S120	6SL3 040-1MA01-0Axx (CU)			2040*		Full
X15	PN IO				2039*		Full
X15	Port 1				2042*		Full
X15	Port 2				2041*		Full
1	Supply_1				2038*		
1.1	Module access point				2038*		Full
1.2	SIEMENS message frame		256...257	256...257			Full
1.3							
2	Drive_1				2037*		
2.1	Module access point				2037*		Full
2.2	PROFIsafe message frame		0...5	0...5			Full
2.3	Standard message frame		258...261	258...261			Full
2.4							
3	Drive_2				2036*		
3.1	Module access point				2036*		Full
3.2	Standard message frame		262...269	262...269			Full
3.3							
4	Drive_3				2035*		
4.1	Module access point				2035*		Full
4.2	PROFIsafe message frame		6...11	6...11			Full
4.3	Standard message frame		270...287	270...279			Full
4.4							
5	Control_Unit				2034*		
5.1	Module access point				2034*		Full
5.2	Free message frame		288...291	288...291			Full
5.3							

Figure 11-44 Updated project in HW Config

There is full access to all telegrams. You must enable this in order that the PROFIsafe controller can access telegram 30.

2. From the shortcut menu of the S120 component, select menu "Object properties...".

- In the following window, you lock the access of the PROFIsafe telegrams through the A-CPU.

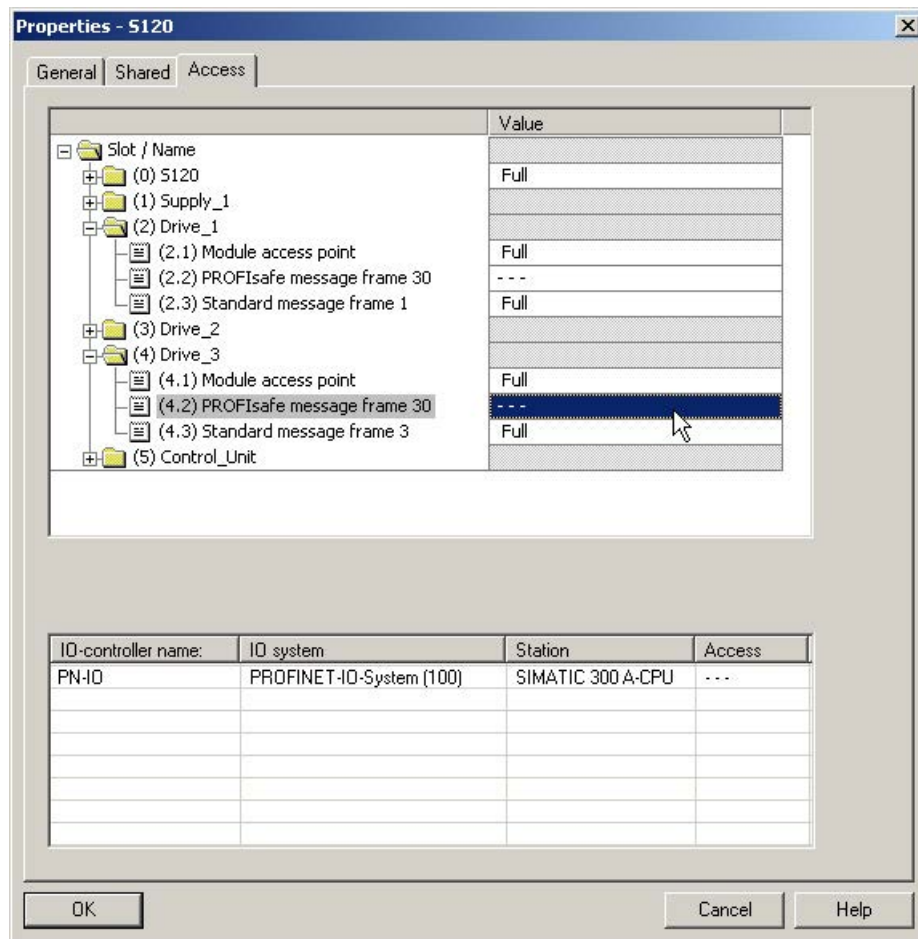

Figure 11-45 Safety telegrams of the A-CPU enabled

Inserting the PROFIsafe controller in STEP 7

You configure the PROFIsafe controller in precisely the same way as the drive control under STEP 7.

Configuring the F-CPU in HW Config

1. Different than for a drive control, now select a PROFIsafe-compatible controller, for example, a CPU 317F-2 PN/DP.
We have manually renamed the PROFIsafe controller to "F-CPU".
2. To establish the communication, select PROFINET IO again.

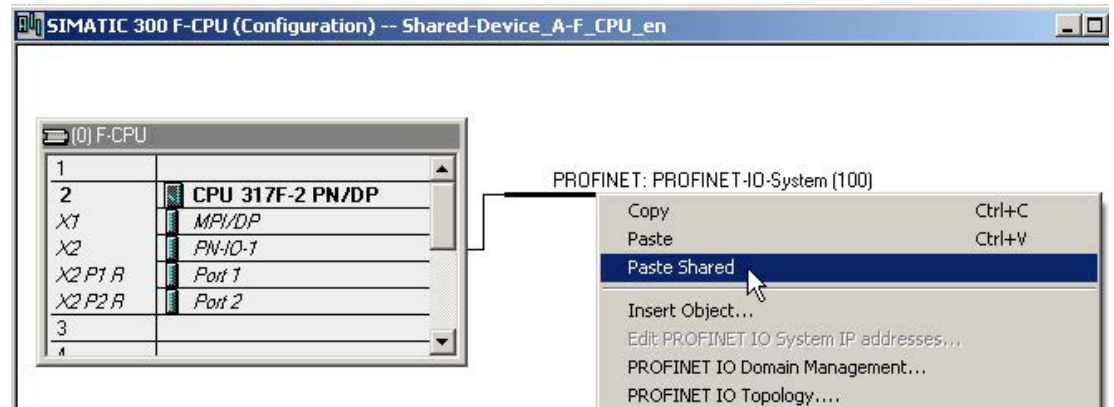

Figure 11-46 PROFIsafe controller configuration

3. In HW Config, click "Station\Save and compile".
4. Click the S120 component in the drive control window.
5. In the menu, select "Edit/copy" to start copying.
6. Return to the HW Config window of the PROFIsafe controller.
7. Right-click the PROFINET line.

11.3 Communication via PROFINET IO

8. In the shortcut menu, select "Insert shared".

The S120 drive control is connected to the PROFINET of the PROFIsafe controller. In the table, the PROFIsafe controller has automatically been allocated full access for PROFIsafe telegram 30.

The image shows two side-by-side screenshots of the HW Config software interface. The left window is titled 'SIMATIC 300 A-CPU (Configuration) -- Shared-Device_A-F_CPU_en' and shows a rack configuration for a CPU 315-2 PN/DP. The right window is titled 'SIMATIC 300 F-CPU (Configuration) -- Shared-Device_A-F_CPU_en' and shows a rack configuration for a CPU 317F-2 PN/DP. Both windows show a connection to a PROFIsafe controller (S120). Below each window is a table of module addresses and access permissions.

Slot	Module	Order number	I address	Q address	Diagnosics address	Comm.	Access
0	S120	6ES7 040-1MA01-0AA0 (CPU)			2040*		Full
X14	PN-IO				,2020*		Full
X14	Port 1				,3040*		Full
X14	Port 2				,3040*		Full
1	Control Unit				2038*		Full
1.1	Module access point				,2038*		Full
1.2	Free message frame		286..289	286..289			Full
1.3							
2	Supply_1				2037*		Full
2.1	Module access point				,2037*		Full
2.2	SIEMENS message frame		280..281	280..281			Full
2.3							
3	Drive_1				2036*		Full
3.1	Module access point				,2036*		Full
3.2	PROFIsafe message frame						Full
3.3	Standard message frame		282..285	282..285			Full
3.4							
4	Drive_2				2035*		Full
4.1	Module access point				,2035*		Full
4.2	Standard message frame		286..273	286..273			Full
4.3							
5	Drive_3				2034*		Full
5.1	Module access point				,2034*		Full
5.2	PROFIsafe message frame						Full
5.3	Standard message frame		274..291	274..283			Full
5.4							
5.5							
5.6							
5.7							

Figure 11-47 New project completed in HW Config

9. In HW Config, click "Station\Save and compile".

10. Click "Open object with STARTER" again

After completing the last save operation, you will see in the STARTER window that the PROFIsafe telegrams have been assigned to PN-IO-1 and the drive telegrams to PN-IO.

IF1: PROFIdrive PZD message frames		IF2: PZD message frames							
Communication interface: PROFINET - Control Unit onboard (isochronous)									
The PROFIsafe communication is performed via this interface									
The PROFIdrive message frames of the drive objects are transferred in the following order:									
The input data corresponds to the send and the output data of the receive direction of the drive object.									
Master view:									
Object	Drive object	-No.	Assigned controller	Message frame type		Input data		Output data	
						Length	Address	Length	Address
1	Control_Unit	1	PN-IO	Free telegram configuration with BICO	✓	2	256..259	2	256..259
2	Supply_1	2	PN-IO	SIEMENS telegram 370, PZD-1/1	✓	1	260..261	1	260..261
3	Drive_1	3	PN-IO-1	PROFIsafe standard telegram 30, PZD-	✓	3	0..5	3	0..5
			PN-IO	Standard telegram 1, PZD-2/2	✓	2	262..265	2	262..265
4	Drive_2	4	PN-IO	Standard telegram 2, PZD-4/4	✓	4	266..273	4	266..273
5	Drive_3	5	PN-IO-1	PROFIsafe standard telegram 30, PZD-	✓	3	6..11	3	6..11
			PN-IO	Standard telegram 3, PZD-5/9	✓	9	274..291	5	274..283
Without PZDs (no cyclic data exchange)									

Figure 11-48 New project completed in STARTER

If there is a checkmark after each telegram type in STARTER, then the Shared Device has been successfully configured.

11.3.8.3 Overview of important parameters

Overview of important parameters (see SINAMICS S120/S150 List Manual)

- p8929 PN number of remote controllers
- p9601 SI enable functions integrated in the drive (Control Unit)
- p9801 SI enable functions integrated in the drive (Motor Module)

11.3.9 PROFINET system redundancy

11.3.9.1 Overview

Thanks to SINAMICS S120 PROFINET Control Unit, the assembly of system-redundant systems is possible.

Precondition for system-redundant systems is a so-called H-system. The H-system consists of 2 fault-tolerant controls – master and reserve CPU – which are constantly synchronized via fiber-optic cables. If one controller fails, the other automatically takes on the job. This reduces system downtimes.

Preconditions

- SIMATIC controller S7-400H with two PROFINET H-CPU type 41xH
- SINAMICS S120 PROFINET Control Unit (CU310-2 PN or CU320-2 PN)
- Redundant communication links

Benefits

- No system downtime in the case of a controller failure
- Component replacement possible during ongoing operation
- Configuration changes possible during ongoing operation
- Automatic synchronization after replacing components

Restrictions

- IRT is not supported
- No simultaneous operation of Shared Device and Shared I-Device
- Maximum 2 cyclical PROFINET connections
- System redundancy only via the onboard interface of SINAMICS S120 PROFINET Control Unit
- For the duration of switching from one controller to the other, the setpoints of the last connection remain frozen and valid.

11.3.9.2 Design, configuring and diagnostics

Configuration

The figure below shows a sample structure of a system-redundant controller with 3 converters.

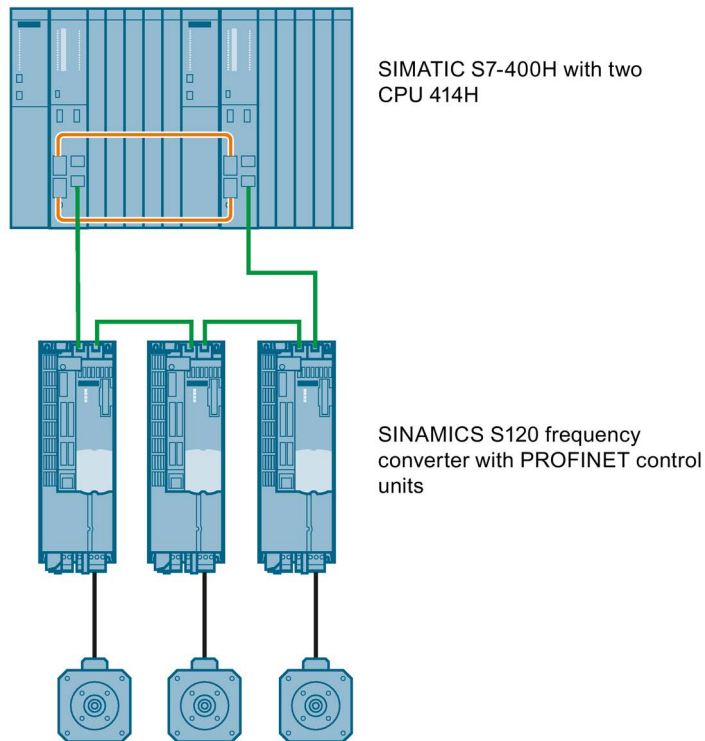

Figure 11-49 System redundancy with converters

Configuring

Configuring the redundancy takes place in STEP 7. In the converter, you only have to configure the communication via PROFINET.

System redundancy does not depend on the topology of the system.

Diagnostics LEDs

Diagnostics states are shown as follows using LEDs with PROFINET system redundancy:

Color	State	Significance
Green	Continuous light	2 redundancy connections available and setpoints are OK.
Green	Flashing light	Only one redundancy connection is available or setpoints are missing.
Red	Flashing light 2 Hz	No connection or setpoint failure (F01910).

Additional information

You can find further descriptions of the PROFINET system redundancy online in the following manuals:

- System manual “Fault-tolerant SIMATIC S7-400H systems”
SIMATICS S7-400H manual
(<https://support.industry.siemens.com/cs/ww/en/view/82478488>)
- Application description Configuration examples for S7-400H PROFINET
SIMATICS S7-400H configuration examples
(<https://support.industry.siemens.com/cs/ww/en/view/90885106>)

11.3.9.3 Messages and parameters

Faults and alarms (see SINAMICS S120/S150 List Manual)

- F01910 (N, A)Fieldbus: Setpoint timeout
- A01980 PN: Cyclic connection interrupt
- A01982 PROFINET: Second controller missing
- A01983 PROFINET: System redundancy switchover

Overview of important parameters (see SINAMICS S120/S150 List Manual)

- r2043.0...2 BO: IF1 PROFIdrive PZD status
- r8843.0...2 BO: IF2 PZD status
- r8936[0...1] PN state of the cyclic connection
- r8937[0...5] PN diagnostics
- r8960[0...2] PN subslot controller assignment
- r8961[0...3] PN IP Address Remote Controller 1
- r8962[0...3] PN IP Address Remote Controller 2

11.3.10 PROFenergy

PROFenergy is an energy management system for production plants, based on the PROFINET communication protocol. The functionality is certified in the PROFenergy profile of the PNO. Drive units which have PROFenergy functionality, can be certified in an approved laboratory. Certified devices support the PROFenergy commands and respond accordingly to the requirements and operating states.

SINAMICS supports the PROFenergy profile V1.1. PROFenergy commands are transferred from the controller to the drive with PROFINET data sets in acyclic operation. The PROFenergy commands are transferred using the PROFINET data set 0x80A0.

PROFenergy data record access is only accepted via the connection types "RT connection" or "IRT connection".

If access is made via another type of connection (e.g. Supervisor connection), system redundancy connection), the data record access is rejected with error code 0x80B0 "Invalid Index".

There is exactly one PROFenergy access point (PESAP) and this hangs on the MAP submodule of the CU drive object.

If access is made via another module/submodule, the data record access is rejected with error code 0x80B0 "Invalid Index".

PROFenergy properties of the SINAMICS S120 drive system

SINAMICS S120 drive system devices meet the following requirements:

- Are certified for PROFenergy
- PROFenergy function unit Class 3
- PROFenergy energy-saving mode 2

SINAMICS devices support the following PROFIenergy functions:

Functions		SINAMICS support								
		S120 SERVO	S120 VECTOR	S150	G110M	G120D	G120x (otherwise not G120D)	G130	G150	ET200 pro FC-2
Control commands		X	X	X	X	X	X	X	X	X
Query commands		X	X	X	X	X	X	X	X	X
Measured values	ID 34	X	X	X	X	X	X	X	X	X
	ID 166	-	X	X	X	X	X	X	X	X
	ID 200	X	X	X	X	X	X	X	X	X
Measuring value access		X	X	X	X	X	X	X	X	X
PROFIenergy energy-saving mode 1	Shutdown Digital outputs	-	-	-	-	X	-	-	-	-
	Shutdown Encoder	-	-	-	-	X	-	-	-	-
PROFIenergy energy-saving mode 2	Switch on interlocking	X	X	X	X	-	X	X	X	X
Inhibit PROFIenergy		X	X	X	X	X	X	X	X	X
PROFIenergy energy-saving mode in PROFIdrive state S3/S4		-	-	-	X	X	X	X	X	X

Figure 11-50 PROFIenergy functions

11.3.10.1 Tasks of PROFlenergy

PROFlenergy is a data interface based on PROFINET. This data interface allows loads to be shut down during non-operational periods in a controlled fashion, and irrespective of the manufacturer and device. Consequently, the process should be given only the energy it actually requires. The majority of the energy is saved by the process, the PROFINET device itself contributes only a few watts to the saving potential.

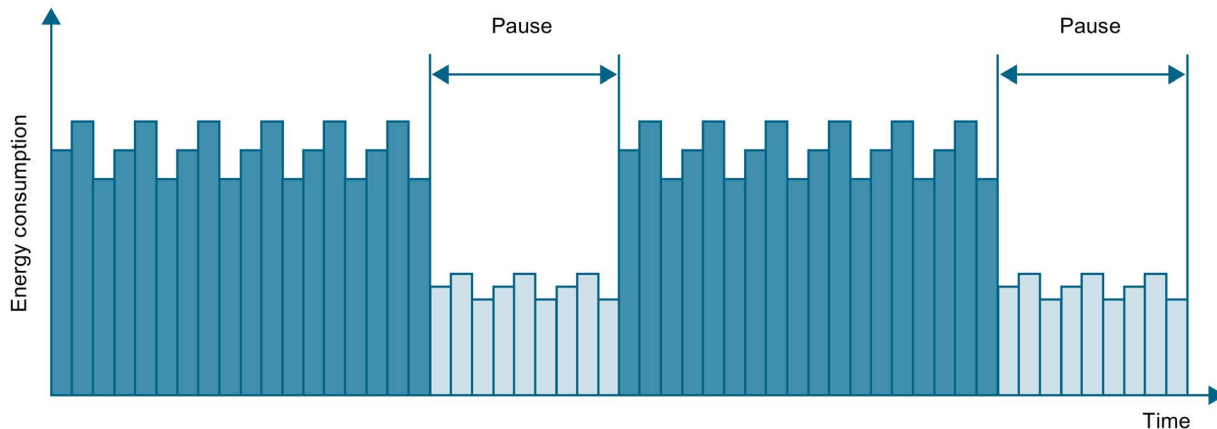

Figure 11-51 Energy saving during pauses with PROFlenergy

The following objectives are reached in detail by temporarily shutting down or stopping unused drives and equipment:

- Lower energy costs.
- Reduction of thermal emissions.
- Longer service life by reducing the effective operating times.
- The drive units provide standardized consumption data for analysis.
- The PROFlenergy state of the participating devices is displayed.
- The PROFlenergy state is available with BICO interconnections for further processing, e.g. to shutdown secondary systems that are not required.

Basics

The PROFINET devices and the power modules are shut down using special commands in the user program of the PROFINET IO controller. No additional hardware is required; the PROFlenergy commands are interpreted directly by the PROFINET devices.

11.3.10.2 PROFenergy commands

Principle of operation

At the start and end of pauses, the plant operator activates or deactivates the pause function of the plant/system after which the IO controller sends the PROFenergy "START_Pause" / "END_Pause" command to the PROFINET devices. The device then interprets the content of the PROFenergy command and switches off or on again.

You can call up device information via additional PROFenergy functions. You can use these to transfer the "START_Pause"/"END_Pause" command in plenty of time.

PROFenergy control commands

Control commands	Description
START_Pause	Switches from the operating state to the energy-saving mode depending on the pause duration. Switches from the energy-saving mode to the operating state depending on the pause duration.
START_Pause_with_time_response	Switches from the operating state to the energy-saving mode and also specifies the transition times in the command response.
END_Pause	Switches from the energy-saving mode to the operating state. Cancels a switch from the operating state to the energy-saving mode.

PROFInergy query commands

Query commands	Description
List_Energy_Saving_Modes	Determines all supported energy-saving modes.
Get_Mode	Determines the energy-saving mode.
PEM_Status	Determines the current PROFInergy status.
PEM_Status_with_CTTO	Determines the current PROFInergy status, such as the PEM status and together with the regular transition time to the operating state.
PE_Identify	Determines the supported PROFInergy commands.
Query_Version	Shows the implemented PROFInergy profile.
Get_Measurement_List	This command returns the measured value IDs that can be accessed using the "Get_Measurement_Values" command.
Get_Measurement_List_with_object_number	This command returns the measured value IDs and the associated object number that can be accessed using the "Get_Measurement_Values_with_object_number" command.
Get_Measurement_Values	<p>The command returns the requested measured value using the measured value ID:</p> <ul style="list-style-type: none"> • For power measured values: The command addresses the sum of the measured value over all control drive objects. • For energy measured values: The command returns the sum of the measured value over all control drive objects. • For power factors: This measured value is supported only for a SINAMICS with a control drive object.
Get_Measurement_Values_with_object_number	<p>This command returns the requested measured values using the measured value ID and the object number. The object number corresponds to the drive object ID.</p> <p>The drive object ID of the Control Unit is used to address the measured values as with "Get_Measurement_Value".</p>

11.3.10.3 PROFenergy measured values

Table 11- 17 Overview of the PROFenergy measured values

PROFenergy measured value		PROFenergy accuracy		Unit	SINAMICS source parameters		Value range
ID	Name	Domain	Class		Parameters	Name	
34	Active power	1	12	W	r0032	Active power smoothed	Largest value for r2004 of all drive objects
166	Power factor	1	12	1	r0038	Smoothed power factor	0 ... 1
200	Active energy import	2	11	Wh	r0039[1]	Energy accepted	-

11.3.10.4 PROFenergy energy-saving mode

SINAMICS S120 drive devices support PROFenergy energy-saving mode 2. The following two parameters indicate the effective PROFenergy mode:

- Parameter r5600 indicates the currently active PROFenergy mode.
- Using interconnectable bits, the r5613 parameter indicates whether the PROFenergy energy saving is active.

Activating the energy-saving mode

The energy-saving mode can be activated or deactivated using the PROFenergy control commands (see also PROFenergy commands (Page 820)).

General inverter behavior when in the PROFenergy energy-saving mode

- When the PROFenergy energy-saving mode is active, the inverter issues alarm A08800.
- When the PROFenergy energy-saving mode is active, the inverter does not send any diagnostic alarms.
- If the bus connection to the control system is interrupted while the inverter is in the energy-saving mode, the inverter exits the energy-saving mode and resumes normal operation ("ready_to_operate").
- The inverter changes into normal operation if the control system goes into the stop condition while the inverter is in the energy-saving mode.

11.3.10.5 PROFenergy inhibit and pause time

Block PROFenergy

If you set p5611.0 = 1, you inhibit the response of the inverter to PROFenergy control commands. In this case, the converter ignores the PROFenergy control commands.

Pause time

- Minimum pause time: p5602
 - When the pause time, which is sent using command "Start_Pause", is equal to or greater than the value in p5602[1], then the inverter goes into the energy-saving mode.
 - If the pause time is less than p5602[1], the inverter ignores the command.
- Maximum duration: p5606

11.3.10.6 Function diagrams and parameters

Function diagrams (see SINAMICS S120/S150 List Manual)

- 2381 PROFenergy - Control commands / query commands
- 2382 PROFenergy - States
- 2610 Sequence control - Sequencer

Overview of important parameters (see SINAMICS S120/S150 List Manual)

- r5600 Pe hibernation ID
- p5602[0...1] Pe hibernation pause time, minimum
- p5606[0...1] Pe hibernation duration, maximum
- p5611 Pe energy-saving properties, general
- r5613.0...1 CO/BO: Pe energy-saving active/inactive

11.3.11 Messages via diagnostics channels

Messages can be displayed not only via the well-known commissioning tools (STARTER, SCOUT). After the activation of a diagnostic function, the messages are also transferred to the higher-level controller via the standardized diagnostic channels. The messages are evaluated there or forwarded for convenient display to the corresponding user interfaces (SIMATIC HMI, TIA Portal, etc.). The messages are shown on the respective user interfaces similarly as in STARTER.

In this way, problems or faults can be located immediately regardless of the tool currently being used, and then corrected immediately.

Also note the general information on the diagnostics channels in Section Diagnostics channels (Page 734).

Activating the diagnostic function

The diagnostics function is activated or deactivated via the parameterization of the relevant configuration tool (HW Config, TIA Portal, etc.).

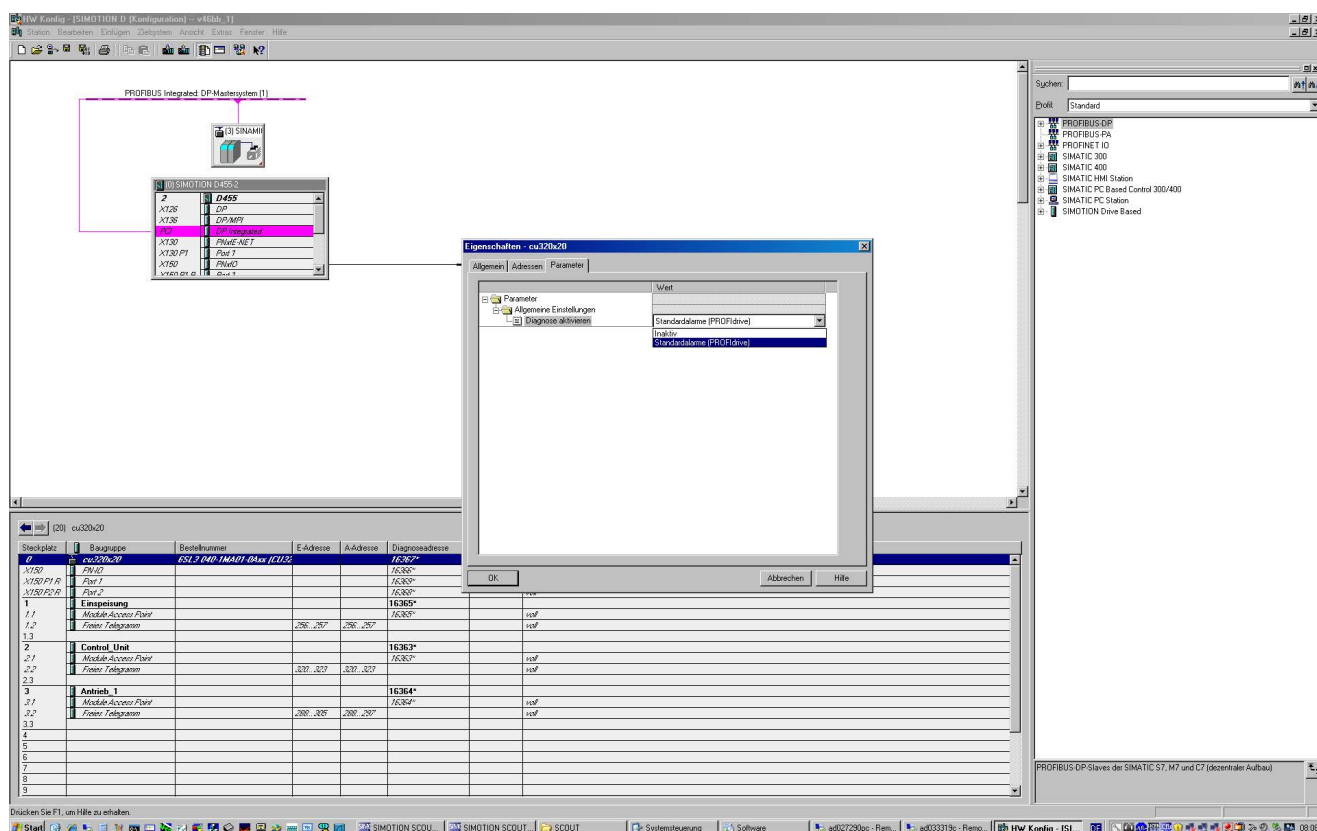

Figure 11-52 Activation of PROFINET

The following parameter assignments are possible:

Setting	Code for parameter assignment
Inactive	0
PROFIdrive error classes	1

When establishing the communication between SINAMICS and a master/controller, the activated diagnostics mode of this controller is first transferred to the drive. With activated diagnostics, SINAMICS first transfers all pending messages to the controller.

Messages

The message texts are described in detail in the SINAMICS S120/S150 List Manual, Chapter "Explanations on the list of faults and alarms". A current list of the message texts can be found in the "Message classes and coding of different diagnostics interfaces" table.

11.3.12 Support of I&M data sets 1...4

Identification & Maintenance (I&M)

I&M data sets contain information for a standardized and simplified identification and maintenance of PROFIBUS/PROFINET devices. I&M data sets 1...4 contain plant-specific information, such as the installation location and date. PROFINET supports I&M data sets 0...4.

I&M data sets 1...3 can be set with the SIMATIC Manager (STEP 7) and also with HW Config (STEP 7).

I&M parameters

Table 11- 18 Parameter designation, assignment and meaning

I&M parameter designation	Format	Size/octets	Initialization	SINAMICS parameters	Meaning
I&M 0: IM_SUPPORTED	-	-	-	r8820[62,63]	The parameter indicates which I&M data sets are supported. The value 0x1E indicates that I&M data sets 1...4 are available.
I&M 1: TAG_FUNCTION	Visible string	32	Space 0x20...0x20	p8806[0...31]	Text that identifies the function or task of the device.
I&M 1: TAG_LOCATION	Visible string	22	Space 0x20...0x20	p8806[32...53]	Text that identifies the device location.
I&M 2: INSTALLATION_DATE	Visible string	16	Space 0x20...0x7E	p8807[0...15]	Text with the date of the installation or the initial commissioning of the device. The following date formats are supported: <ul style="list-style-type: none"> • YYYY-MM-DD • YYYY-MM-DD hh:mm <ul style="list-style-type: none"> - YYYY: Year - MM: Month 01...12 - DD: Day 01...31 - hh: Hours 00...23 - mm: Minutes 00...59 The separators between the individual specifications, i.e. hyphen '-', blank ' ' and colon ':', must be entered.

I&M parameter designation	Format	Size/octets	Initialization	SINAMICS parameters	Meaning
I&M 3: DESCRIPTOR	Visible string	54	Space 0x20...0x20	p8808[0...53]	Text with any comments or notes.
I&M 4: SIGNATURE	Octet string	54	Space 0x00...0x00	p8809[0...53]	<p>The parameter can be filled automatically by the system, in which case it contains a standard value, namely, a functional check signature for the change tracking by Safety Integrated. The check signature has the following format:</p> <ul style="list-style-type: none"> The first four octets (0...3) contain the content of parameter r9781 index 0: "SI change monitoring checksum (Control Unit)". The second four octets (4...7) contain the content of parameter r9782 index 0: "SI change monitoring time stamp (Control Unit)". The remainder (octets 8...53) contains zeroes. <p>Alternatively, a user can enter a user value from an application and so overwrite the standard value. Parameter p8805 specifies which value is entered in p8809:</p> <ul style="list-style-type: none"> p8805 = 0 standard value entered p8805 = 1 user value entered <p>When p8805 = 0 is set, the standard setting for p8809 is restored again.</p>

The I&M data sets 1...4 are stored permanently in parameters p8806...p8809. Significant properties of these four parameters:

- They can be displayed in the STARTER expert list.
- The SINAMICS "Reset parameter" (p0976 = 1, p0970 = 1) function does not have any effect on the content of the parameters.
- I&M data sets are not changed when the alternative parameter sets are stored or loaded. The transfer of parameter sets between a memory card and non-volatile device memory does not have any effect on the I&M data sets.

Overview of important parameters (see SINAMICS S120/S150 List Manual)

- p8805[0...1] Identification and Maintenance configuration
- p8806[0...53] Identification and Maintenance 1
- p8807[0...15] Identification and Maintenance 2
- p8808[0...53] Identification and Maintenance 3
- r8809[0...53] Identification and Maintenance 4

11.3.13 Dynamic IP address assignment

In those cases in which the PROFINET interface is not used for the IO communication, it is possible to generate an IP address centrally using a DHCP (DHCP = Dynamic Host Configuration Protocol) server. The following requirements must be satisfied to do this:

- At least one DHCP server must be active.
- The PG/PC and the SINAMICS devices must be connected to the same physical Ethernet subnet.

Note

DHCP is not supported together with PROFINET. No cyclical connection is established for an activated DHCP. It is therefore recommended that DHCP not be used within PROFINET networks!

The DHCP address assignment can be set from the SIMATIC Manager or using SINAMICS parameters.

Setting the DHCP address assignment with SIMATIC Manager (STEP 7)

1. Call the "Target system > Edit Ethernet node" menu path in the SIMATIC Manager.
2. Click the "Search" button in the "Ethernet nodes" area.
3. Select the desired SINAMICS device.

You can now specify in the "Edit Ethernet nodes" configuration dialog that a dynamic IP address will be generated via a DHCP server. The IP address can be identified in two ways:

- MAC address
- Device name (name of station)

The "MAC address" option has the disadvantage that the MAC addresses are no longer correct after a device replacement.

4. Click the "Obtain the IP address from a DHCP server" option in the dialog to activate.
5. Activate either the "MAC address" or the "Device name" option in the "Identified via" area.
6. Click "Assign IP configuration".

The IP address is then taken from the DHCP server. The SINAMICS device uses the associated setting after a POWER ON to obtain a new IP address from the DHCP server.

Setting the DHCP address assignment with SINAMICS parameters

As an alternative to the address assignment by the SIMATIC Manager, the DHCP address assignment can also be initiated using SINAMICS parameters. In this case, the Control Unit always fetches the IP address from a DHCP server after each POWER ON. You can make the settings using the expert list of the STARTER:

1. Activate the DHCP address assignment using one of the following settings (where the values 2 and 3 mean "MAC address" and "Device name", respectively):

- For Ethernet onboard (X127): p8904 = 2 or 3
- For PROFINET onboard: p8924 = 2 or 3
- For CBE20: p8944 = 2 or 3

The DHCP server now assigns temporarily an IP address.

2. You can now activate the defined interface configuration (each value 1) or activate and store permanently (each value 2). Make one of the following settings:

- For Ethernet onboard (X127): p8905 = 1 or 2
- For PROFINET onboard: p8925 = 1 or 2 (applies only to SINAMICS S120 devices)
- For CBE20: p8945 = 2

A direct activation is not possible for the CBE20. The configuration can only be saved. The setting then becomes automatically active for the next POWER ON.

11.4 Communication via MODBUS TCP

11.4.1 Overview

The Modbus protocol is a communication protocol based on a master/slave architecture.

Modbus offers three transmission modes:

- **Modbus ASCII** - via a serial interface
data in the ASCII code. The data throughput is lower compared to RTU.
- **Modbus RTU** - via a serial interface
data in the binary format. The data throughput is greater than in ASCII code.
- **Modbus TCP** - via Ethernet
data as TCP/IP packages. TCP port 502 is reserved for Modbus TCP.

Only transfer type "Modbus TCP" is available for SINAMICS S120.

Possible drive units:

- CU320-2 PN
- CU320-2 DP
- CU310-2 PN

Modbus functionality

Process data and parameters are accessed via the Modbus register.

- Process data: 40100 - 40119
- Drive data: 40300 - 40522
- All parameters via DS47: 40601 - 40722

Modbus TCP always provides a basic Ethernet functionality, which corresponds to the functionality of Ethernet interface X127:

- Commissioning access for STARTER/Startdrive with S7 protocol
- DCP to set the IP address etc.
- SNMP for identification

General information about communication

Communication with Modbus TCP runs via the Ethernet/PROFINET interfaces:

- **X150:**

For Modbus TCP with a CU320-2 PN or CU310-2 PN.

- **X1400:**

For Modbus TCP with a CU320-2 PN or a CU320-2 DP via a CBE20.

Precisely one Modbus connection can be established. A simultaneous connection via interfaces X150 and X1400 is rejected, and is acknowledged using Alarm A08555.

However, you can use one interface for Modbus TCP, and the other as PROFINET interface.

Drive object that can be addressed via Modbus

With Modbus TCP, you always address drive object DO1 from the list of drive objects (p0978[0]). A servo or vector drive object must be in this parameter.

However, Modbus TCP is only activated if, under p0978[0], there is a drive object that is supported by Modbus TCP. If p0978[0] does not contain a valid drive object, then establishing communication is acknowledged with Alarm A08555.

Diagnostics LEDs in Modbus TCP

Diagnostics states are shown as follows using LEDs with Modbus TCP:

Color	State	Significance
Green	Continuous light	Connections and setpoints are OK.
Green	Flashing light	Connection is OK, but no setpoints (dependent on timeout).
Red	Flashing light 2 Hz	No connection or setpoint timeout.

11.4.2 Configuring Modbus TCP via interface X150

Activate Modbus TCP via X150 (CU320-2 PN or CU310-2 PN)

1. For drive object DO1, set p2030 = 13 (Modbus TCP).
2. Using p8921, set the IP address for the onboard PROFINET interface on the Control Unit.
3. Set the standard gateway using p8922.
4. Set the subnet mask using p8923.
5. Set the DHCP mode using p8924.
6. Select "Activate and save configuration" as interface configuration using p8925 = 2.
7. In the STARTER commissioning tool, check the list of drive object p0978.
 When required, change the sequence of the drive objects using the telegram configuration ("Drive device" > "Communication" > "Telegram configuration").
8. Save the settings in the STARTER commissioning tool and carry out a POWER ON.

Modbus settings with interface X150

Using the following parameters, set the communication for Modbus TCP with a X150 interface:

Parameters	Explanation
p2040	Setting the monitoring time to monitor the received process data via fieldbus interface. If process data is not transferred within one cycle of the fieldbus monitoring time, then the drive shuts down with fault F01910.
r2050[0...19]	Connector output to interconnect the PZD received from the fieldbus controller via IF1.
p2051[0...24]	Selects the PZD (actual values) to be sent to the fieldbus controller in the word format via IF1.
r2053[0...24]	Displays the PZD (actual values) sent to the fieldbus controller in the word format via IF1.
r2054	Status display for the internal communication interface.
p8839[0...1]	Assigning the PN onboard interface (x150) via PZD interface 1 (IF1) and interface 2 (IF2).
r8850[0...19]	Connector output to interconnect the PZD (setpoints) received in the word format via IF2.
p8851[0...24]	Selects the PZD (actual values) to be sent in the word format via IF2.
r8853[0...24]	Displays the PZD (actual values) sent in the word format via IF2.
r8854	Status display for COMM BOARD.

11.4.3 Configuring Modbus TCP via interface X1400

Activating Modbus TCP via X1400 (CBE20)

1. For drive object DO1, set p8835 = 5 (Modbus TCP).
2. Set the IP address for the CBE20 using p8941.
3. Set the standard gateway for the CBE20 using p8942.
4. Set the subnet mask for the CBE20 using p8943.
5. Set the DHCP mode for the CBE20 using p8944.
6. Select the setting "Activate and save configuration" as interface configuration using p8945 = 2.
7. In the STARTER commissioning tool, check the list of drive object p0978.
When required, change the sequence of the drive objects using the telegram configuration ("Drive device" > "Communication" > "Telegram configuration").
8. Save the settings in the STARTER commissioning tool and carry out a POWER ON.

Modbus settings with interface X1400

Using the following parameters, set the communication for Modbus TCP with a X1400 interface:

Parameters	Explanation
r2050[0...19]	Connector output to interconnect the PZD received from the fieldbus controller via IF1.
p2051[0...24]	Selects the PZD (actual values) to be sent to the fieldbus controller in the word format via IF1.
r2053[0...24]	Displays the PZD (actual values) sent to the fieldbus controller in the word format via IF1.
r2054	Status display for the internal communication interface.
p8840	Setting the monitoring time to monitor the received process data via the COMM BOARD. If, within this time, the Control Unit does not receive any process data from the COMM BOARD, then the drive shuts down with fault F08501.
p8839[0...1]	Assigning the CBE20 interface (x1400) for cyclic communication via PZD interface 1 (IF1) and interface 2 (IF2).
r8850[0...19]	Connector output to interconnect the PZD (setpoints) received in the word format via IF2.
p8851[0...24]	Selects the PZD (actual values) to be sent in the word format via IF2.
r8853[0...24]	Displays the PZD (actual values) sent in the word format via IF2.
r8854	Status display for COMM BOARD.

11.4.4 Mapping tables

Modbus register and Control Unit parameters

The Modbus protocol contains register or bit numbers for addressing memory. You must assign the appropriate control words, status words and parameters to these registers in the slave.

The valid holding register address range extends from 40001 up to 40722. When trying to access other holding registers, the "Exception code" error is output

The process data are transferred into the register range from 40100 up to 40119.

Note

"R"; "W"; "R/W" in the "Access" column stands for read (with FC03); write (with FC06); read/write.

Table 11- 19 Assigning the Modbus register to the parameters - process data

Register	Description	Access	Unit	Scaling	ON/OFF text or Value range	Data / parameter
Control data						
40100	Control word (see SINAMICS S120/150 List Manual, function diagram 2442)	R/W	-	1	-	Process data 1
40101	Main setpoint	R/W	-	1	-	Process data 2
40102	STW 3	R/W	-	1	-	Process data 3
40103	STW 4	R/W	-	1	-	Process data 4
40104	PZD 5	R/W	-	1	-	Process data 5
40105	PZD 6	R/W	-	1	-	Process data 6
40106	PZD 7	R/W	-	1	-	Process data 7
40107	PZD 8	R/W	-	1	-	Process data 8
40108	PZD 9	R/W	-	1	-	Process data 9
40109	PZD 10	R/W	-	1	-	Process data 10
Status data						
40110	Control word (see SINAMICS S120/150 List Manual, function diagram 2452)	R	-	1	-	Process data 1
40111	Main actual value	R	-	1	-	Process data 2
40112	ZSW 3	R	-	1	-	Process data 3
40113	ZSW 4	R	-	1	-	Process data 4
40114	PZD 5	R	-	1	-	Process data 5
40115	PZD 6	R	-	1	-	Process data 6
40116	PZD 7	R	-	1	-	Process data 7
40117	PZD 8	R	-	1	-	Process data 8
40118	PZD 9	R	-	1	-	Process data 9
40119	PZD 10	R	-	1	-	Process data 10

Table 11- 20 Assigning the Modbus register to the parameters - parameter data

Register	Description	Access	Unit	Scaling	ON/OFF text or Value range	Data / parameter
Drive identification						
40300	Actual power unit code number	R	-	1	0 ... 65535	r0200
40301	Control Unit firmware	R	-	1	0 ... 65535	r0018 / 10000
Drive data						
40320	Rated power of the power unit	R	kW	100	0 ... 655.35	r0206
40321	Current limit	R/W	%	10	0.0 ... 6553.5	p0640
40322	Ramp-up time ¹⁾	R/W	s	100	10.00 ... 655.35	p1120
40323	Ramp-down time ¹⁾	R/W	s	100	10,00 ... 655.35	p1121
40324	Reference speed ²⁾	R/W	RPM	1	6 ... 65535	p2000
Drive diagnostics						
40340	Speed setpoint ²⁾	R	RPM	1	-32768 ... 32767	r0020
40341	Speed actual value ²⁾	R	RPM	1	-32768 ... 32767	r0021
40342	Output frequency	R	Hz	100	- 327.68 ... 327.67	r0024
40343	Output voltage	R	V	1	0 ... 65535	r0025
40344	DC link voltage	R	V	1	0 ... 65535	r0026
40345	Actual current value	R	A	100	0 ... 655.35	r0027
40347	Actual active power	R	kW	100	0 ... 655.35	r0032
40349	Control priority	R	-	1	HAND AUTO	r0807
Fault diagnostics						
40400	Failure number, index 0	R	-	1	0 ... 65535	r0947 [0]
40401	Failure number, index 1	R	-	1	0 ... 65535	r0947 [1]
40402	Failure number, index 2	R	-	1	0 ... 65535	r0947 [2]
40403	Fault number, index 3	R	-	1	0 ... 65535	r0947 [3]
40404	Fault number, index 4	R	-	1	0 ... 65535	r0947 [4]
40405	Fault number, index 5	R	-	1	0 ... 65535	r0947 [5]
40406	Fault number, index 6	R	-	1	0 ... 65535	r0947 [6]
40407	Fault number, index 7	R	-	1	0 ... 65535	r0947 [7]
40408	Alarm number	R	-	1	0 ... 65535	r2110 [0]
40409	Actual alarm code	R	-	1	0 ... 65535	r2132
40499	PRM ERROR code	R	-	1	0 ... 255	-
Technology controller³⁾						
40500	Technology controller enable	R/W	-	1	0 ... 1	p2200, r2349.0
40501	Technology controller MOP	R/W	%	100	-200.0 ... 200.0	p2240

Register	Description	Access	Unit	Scaling	ON/OFF text or Value range	Data / parameter
Adapt technology controller³⁾						
40510	Time constant for actual-value filters of the technology controller	R/W	-	100	0.00 ... 60.0	p2265
40511	Scaling factor for actual value of the technology controller	R/W	%	100	0.00 ... 500.00	p2269
40512	Proportional amplification of the technology controller	R/W	-	1000	0.000 ... 65.535	p2280
40513	Integral time of the technology controller	R/W	s	1	0 ... 60	p2285
40514	Time constant D-component of the technology controller	R/W	-	1	0 ... 60	p2274
40515	Max. limit of technology controller	R/W	%	100	-200.0 ... 200.0	p2291
40516	Min. limit technology controller	R/W	%	100	-200.0 ... 200.0	p2292
PID diagnostics						
40520	Effective setpoint acc. to internal technology controller MOP ramp-function generator	R	%	100	-100.0 ... 100.0	r2250
40521	Actual value of technology controller after filter	R	%	100	-100.0 ... 100.0	r2266
40522	Output signal technology controller	R	%	100	-100.0 ... 100.0	r2294

- 1) For these registers, for S120 servo drives, parameters p1120 and p1121 are only available (and can only be parameterized) with the extended setpoint channel.
- 2) These registers are not supported for linear motors as the unit and value range differ from normal rotary drives.
- 3) The technology controller parameters can only be accessed if, in the STARTER project, also the "Technology controller" function module is activated.

Table 11- 21 Assignment of the Modbus register for general parameter access using DS47

Register	Description	Access	Unit	Scaling	ON/OFF text or Value range	Data / parameter
40601	DS47 Control	R/W	-	-	-	-
40602	DS47 header	R/W	-	-	-	-
40603	DS47 data 1	R/W	-	-	-	-
...	...					
40722	DS47 data 120	R/W	-	-	-	-

Note**Limited value range**

Modbus TCP registers have a maximum 16 bit width. The values of display parameters (r parameters) cannot always be represented with 16 bits. In these particular cases, the maximum value that can be represented is displayed.

- Unsigned: 65535
- Signed min: -32768
- Signed max: 32767

11.4.5 Write and read access using function codes

Function codes used

For data exchange between the master and slave, predefined function codes are used for communication via Modbus.

The Control Unit uses the following Modbus function codes:

- FC 03: Holding register to read data from the inverter
- FC 06: Write single register to write to individual register
- FC 16: Write to multiple registers to write to several registers

Structure of a Modbus TCP message

Application Data Unit (ADU)					
Modbus Application Header				Protocol Data Unit (PDU)	
Transaction ID	Protocol ID	Length	Unit ID	FCCode	Data
2 Bytes	2 Bytes	2 Bytes	1 Byte	1 Byte	0 ... 252 Bytes

Figure 11-53 Individual components, including Modbus Application Header (MBAP) and function code

Structure of a read request via Modbus function code 03 (FC 03)

Any valid register address is permitted as the start address.

Via FC 03, the control can address more than one register with one request. The number of addressed registers is contained in bytes 10 and 11 of the read request.

Table 11- 22 Structure of a read request via slave number 17, example

Value	Byte	Description
MBAP header		
03 h	7	
00 h	8	Register start address "High" (register 40110)
6D h	9	Register start address "Low"
00 h	10	Number of registers "High" (2 registers: 40110; 40111)
02 h	11	number of registers "Low"

The response returns the corresponding data set:

Table 11- 23 Slave response to the read request, example

Value	Byte	Description
MBAP header		
03 h	7	
04 h	8	Number of bytes (4 bytes are returned)
11 h	9	Data first register "High"
22 h	10	Data first register "Low"
33 h	11	Data second register "High"
44 h	12	Data second register "Low"

Table 11- 24 Invalid read request

Read request	Inverter response
Invalid register address	Exception code 02 (invalid data address)
Read a write-only register	Telegram in which all values are set to 0.
Read a reserved register	
Controller addresses more than 125 registers	Exception code 03 (invalid data value)
The start address and the number of registers of an address are located outside of a defined register block	Exception code 02 (invalid data address)

Structure of a write request via Modbus function code 06 (FC 06)

Start address is the holding register address.

Via FC 06, with one request, only precisely one register can be addressed. The value, which is written to the addressed register, is contained in bytes 10 and 11 of the write request.

Table 11- 25 Structure of a write request for slave number 17, example

Value	Byte	Description
MBAP header		
06 h	7	Function code
00 h	8	Register start address "High" (write register 40100)
63 h	9	Register start address "Low"
55 h	10	Register data "High"
66 h	11	Register data "Low"

The response returns register address (bytes 8 and 9) and the value (bytes 10 and 11), which the higher-level control had written to the register.

Table 11- 26 Slave response to the write request, example

Value	Byte	Description
MBAP header		
06 h	7	Function code
00 h	8	Register start address "High"
63 h	9	Register start address "Low"
55 h	10	Register data "High"
66 h	11	Register data "Low"

Table 11- 27 Invalid write request

Write request	Inverter response
Incorrect address (a holding register address does not exist)	Exception Code 02 - invalid data address
Write to a "read-only" register	Exception Code 04 - device failure
Write to a reserved register	

For Exception Code 4, via the holding register 40499, you can read out the internal drive error code, which has occurred for the last parameter access via the holding register.

11.4.6 Communication via data set 47

Via FC 16, with one request, up to 122 registers can be written to directly one after the other, while for Write Single Register (FC 06) you must individually write the header data for each register.

Header

In addition to the transfer type, the start address and the number of the following registers in the header.

User data

You control the access in the user data via register 40601.

In register 40602, you define the access as well as the length of the request data.

Register 40603 contains the request reference - it is defined by the user - and the access type -reading or writing.

From register 40603 and higher, the request aligns communication via data set 47 according to PROFIdrive.

Register 40604 contains the number of the drive object and the number of parameters that are read out or written to.

Register 40605 contains the attribute that you use to control whether you read out the parameter value or the parameter attribute. In the number of elements you specify how many indices are read.

11.4.6.1 Communication details

General parameter access is realized using the Modbus register 40601 ... 40722.

Communication via DS47 is controlled using 40601. 40602 contains the function code (always = 47 = 2F hex) and the number of the following user data. User data are contained in registers 40603 ... 40722.

Communication overview

Value in the register				Explanation
40601	40602	40603 ... 40722		
0	47	Write values for acyclic access
1	47	Request length [bytes]	Request data	Activate acyclic access
2	47	Response length [bytes]	Response data	Response for a successful request
2	47	0	Error code	Response for an erroneous request

Error codes

- 1 hex: Invalid Length (invalid length)
- 2 hex: Invalid State (in the actual inverter state, this action is not permitted)
- 3 hex: Invalid function code (FC ≠ 2F hex)
- 4 hex: Response not ready (the response has still not been issued)
- 5 hex: Internal Error (general system error)

Incorrect access operations to parameters via data set 47 are logged in registers 40603 ... 40722. The error codes are described in the PROFIdrive profile.

11.4.6.2 Examples: Read parameter

Table 11- 28 Write parameter request: Reading the parameter value of r0002 from slave number 17

Value	Byte	Description
MBAP header		
10 h	7	Function code (write multiple)
0258 h	8,9	Register start address
0007 h	10,11	Number of registers to be read (40601 ... 40607)
0E h	12	Number of data bytes (7 registers, each 2 bytes = 14 bytes)
0001 h	13,14	40601: DS47 Control = 1 (activate request)
2F0A h	15,16	40602: Function 2F h (47), request length 10 bytes (0A h)
8001 h	17,18	40603: Request reference = 80 h, request identifier = 1 h
0101 h	19,20	40604: DO-Id = 1, number of parameters = 1
1001 h	21,22	40605: Attribute, number of elements = 1
0002 h	23,24	40606: Parameter number = 2
0000 h	25,26	40607: Subindex = 0

Table 11- 29 Start parameter request: Reading the parameter value of r0002 from slave number 17

Value	Byte	Description
MBAP header		
03 h	7	Function code (read)
0258 h	8,9	Register start address
0007 h	10,11	Number of registers to be read (40601 ... 40607)
0010 h	12,13	Number of registers

Table 11- 30 Response for successful read operation

Value	Byte	Description
MBAP header		
03 h	7	Function code (read)
20 h	8	Number of following data bytes (20 h: 32 bytes $\hat{=}$ 16 registers)
0002 h	9,10	40601: DS47 Control = 2 (the request was executed)
2F08 h	11,12	40602: Function code 2F h (47), response lengths 8 bytes
8001 h	13,14	40603: Request reference mirrored = 80 h, response identifier = 1 (request parameter)
0101 h	15,16	40604: DO-ID = 1, number of parameters = 1
0301 h	17,18	40605: Format, number of elements = 1
001F h	19,20	40606: Parameter value = 1F h (31)

Table 11- 31 Response for unsuccessful read operation - read request still not completed

Value	Byte	Description
MBAP header		
03 h	7	Function code (read)
20 h	8	Number of following data bytes (20 h: 32 bytes $\hat{=}$ 16 registers)
0001 h	9,10	40601: Check value 1 = request is processed
2F00 h	11,12	40602: Function 2F h(47), response length 0 (fault)
0004 h	13,14	40603: Error code: 0004 Response Not Ready (response has still not been issued)

11.4.6.3 Examples: Write parameter

Table 11- 32 Write parameter request: Writing the parameter value of p1121 from slave number 17

Value	Byte	Description
MBAP header		
10 h	7	Function code (write multiple)
0258 h	8,9	Register start address
000A h	10,11	Number of registers to be written to (40601 ... 40610)
14 h	12	Number of data bytes (10 registers, each 2 bytes = 20 bytes)
0001 h	13,14	40601: C1 (activate request)
2F10 h	15,16	40602: Function 2F h (47), request length 16 bytes (10 h)
8002 h	17,18	40603: Request reference = 80 h, request identifier = 2 h (write)
0101 h	19,20	40604: DO-Id = 1, number of parameters = 1
1001 h	21,22	40605: Attribute, number of elements = 1
0461 h	23,24	40606: Parameter number = 1121
0000 h	25,26	40607: Subindex = 0
0801 h	27,28	40608: Format + number of values
4142 h	29,30	40609: Parameter value 12,15
6666 h	31,32	40610: Parameter value

Table 11- 33 Start parameter request: Writing the parameter value of p1121 from slave number 17

Value	Byte	Description
MBAP header		
03 h	7	Function code (read)
0258 h	8,9	Register start address
0007 h	10,11	Number of registers to be written to (40601 ... 40610)
0010 h	12,13	Number of registers

Table 11- 34 Response for successful write operation

Value	Byte	Description
MBAP header		
03 h	7	Function code (read)
20 h	8	Number of following data bytes (20 h: 32 bytes $\hat{=}$ 16 registers)
0002 h	9,10	40601: DS47 Control = 2 (request was executed)
2F04 h	11,12	40602: Function code 2F h (47), response length 4 bytes
8002 h	13,14	40603: Request reference mirrored = 80 h, response identifier = 2 (change parameter)
0101 h	15,16	40604: DO-ID = 1, number of parameters = 1

Table 11- 35 Response for unsuccessful write operation - write request still not completed

Value	Byte	Description
MBAP header		
03 h	7	Function code (read)
20 h	8	Number of following data bytes (20 h: 32 bytes $\hat{=}$ 16 registers)
0001 h	9,10	40601: DS47 Control = 1 (request is processed)
2F00 h	11,12	40602: Function 2F h(47), response length 0 (fault)
0004 h	13,14	40603: Error code: 0004 Response Not Ready (response has still not been issued)

11.4.7 Communication procedure

Logical error

If the slave detects a logical error within a request, it responds to the master with an "exception response". In the response, the slave sets the highest bit in the function code to 1. If the slave receives, for example, an unsupported function code from the master, the slave responds with an "exception response" with code 01 (Illegal function code).

Table 11- 36 Overview of exception codes

Exception code	Modbus name	Remark
01	Illegal function code	An unknown (unsupported) function code was sent to the slave.
02	Illegal Data Address	An invalid address was requested.
03	Illegal data value	An invalid data value was detected.
04	Server failure	Slave has terminated during processing.

Process data monitoring time (setpoint timeout)

The "Setpoint timeout" only applies for access to process data (40100 ... 40109, 40110 ... 40119). The "Setpoint timeout" is not generated for parameter data (40300 ... 40522).

Fieldbus interface:

In parameter p2040 you define the time for cyclic data exchange for process data.

Setting range 0 ... 20 ms.

The time depends on the amount of data to be transferred and the control.

"Setpoint timeout" (F01910) is issued by the Modbus if p2040 is set to a value > 0 ms and no process data is requested within this time period.

COMM BOARD:

In parameter p8840 you define the time for cyclic process data exchange.

Setting range 0 ... 20 ms.

The time depends on the amount of data to be transferred and the control.

"Setpoint timeout" (F08501) is issued by the Modbus if p8840 is set to a value > 0 ms and no process data is requested within this time period.

11.4.8 Messages and parameters

Faults and alarms (see SINAMICS S120/S150 List Manual)

- F01910 Fieldbus: Setpoint timeout
- A01925 Modbus TCP connection interrupted
- F08501 PN/COMM BOARD: Setpoint timeout
- A08526 PN/COMM BOARD: No cyclic connection
- A08555 Modbus TCP commissioning fault

Overview of important parameters (see SINAMICS S120/S150 List Manual)

- p0978[0...n] List of drive objects
- p2030 Fieldbus interface protocol selection
- p2040 Fieldbus interface monitoring time:
- r2050[0...19] CO: IF1 PROFIdrive PZD receive word
- p2051[0...24] CI: IF1 PROFIdrive PZD send word
- r2053[0...24] IF1 PROFIdrive diagnostics PZD send word
- r2054 PROFIBUS status
- p8835 CBE20 firmware selection
- p8839[0...1] PZD interface hardware assignment
- p8840 COMM BOARD monitoring time
- r8850[0...19] CO: IF2 PZD receive word
- p8851[0...24] CI: IF2 PZD send word
- r8853[0...24] IF2 diagnostics PZD send
- r8854 COMM BOARD state
- p8920[0...239] PN Name of Station
- p8921[0...3] PN IP address
- p8922[0...3] PN default gateway
- p8923[0...3] PN Subnet Mask
- p8924 PN DHCP mode
- p8925 PN interfaces configuration
- p8940[0...239] CBE2x Name of Station
- p8941[0...3] CBE2x IP address
- p8942[0...3] CBE2x Default Gateway
- p8943[0...3] CBE2x Subnet Mask
- p8944 CBE2x DHCP mode
- p8945 CBE2x interfaces configuration

11.5 Communication via EtherNet/IP

11.5.1 Overview

EtherNet/IP (short: EIP) is real-time Ethernet, and is mainly used in automation technology. For communication via EtherNet/IP, you require an Ethernet CBE20 option board.

Communication with EIP is not possible via an onboard interface.

Possible drive units:

- CU320-2 PN
- CU320-2 DP

11.5.2 Connect drive device to Ethernet/IP

In order that your drive can be connected to a control system via Ethernet, your control system requires a generic I/O module for cyclic communication via EtherNet/IP. You manually create this generic I/O module in the control system.

Create generic I/O module and connect the drive to the control system

To connect the drive to a control system via Ethernet, proceed as follows:

1. Connect the drive to the control system via an Ethernet cable.
2. In your control, create a generic I/O module with EtherNet/IP functionality.
 - Insert a new module in your control system.
 - Select a generic Ethernet module from the selection.
 - Enter the network parameters for the newly inserted module (IP address, subnet mask, standard gateway, station name).

3. For the generic I/O module, enter the lengths of the process data for cyclic communication, which you have selected in STARTER, r2067[0] (input), r2067[1] (output), for example: Standard telegram 2/2.

In the STARTER telegram configuration, read out the length of the process data for all drive objects (for input and output) - and add them (see PROFIdrive "Process data (Page 704)").

- Input 101:

Here, enter the sum of all input process data of your drive objects from STARTER.

- Output 102:

Here, enter the sum of all output process data of your drive objects from STARTER.

- Configuration 1 or 103:

Here, always enter a value of 0.

4. In STARTER, set the same values for IP address, subnet mask, standard gateway and the name station as in the control system (see Chapter Configuring communication (Page 850))

Result:

You have connected the drive to the control system via EtherNet/IP.

Further, you can find a detailed description of how to create a generic I/O module on the following Internet page:

(Creating a generic I/O module

<http://support.automation.siemens.com/WW/view/en/92045369>)).

Routing and shielding Ethernet cables

You can find information on how to do this on the following Internet page:

Ethernet IP (<https://www.odva.org/Publication-Download>).

Commissioning the drive in an EtherNet/IP network

To commission the drive, connect the drive via an interface (depending on the Control Unit type: PROFIBUS, PROFINET, Ethernet, etc) with your computer, on which STARTER, version ≥ 4.5 is installed.

You can find additional information in the SINAMICS S120 Commissioning Manual STARTER.

11.5.3 Requirements for communication

Check the communication settings using the following questions. If you answer "Yes" to the questions, you have correctly set the communication settings and can control the drive via the fieldbus.

- Is the drive correctly connected to the EtherNet/IP?
- Has a generic module been created in your control system?
- Have the bus interface and IP address been correctly set?
- Have the signals that the drive and the control system exchange been correctly interconnected?

11.5.4 Configuring communication

Make the communication settings

Make the following settings for the CBE20 in order to communicate with a higher-level control via EtherNet/IP:

1. With p8835 = 4, set the firmware version "EtherNet/IP".
2. Set the IP address using p8941.
You can find the currently valid address in r8951.
3. Set the subnet mask using p8943.
You can find the currently valid subnet mask in r8953.
4. Set the standard gateway using p8942.
You can find the currently valid standard gateway in r8952.
5. Set the station name using p8940.
You can find the currently valid station name in r8950.
6. Select the setting "Save and activate configuration" as interface configuration using p8945 = 2.
7. Save the data using command "Copy RAM to ROM".
Then switch off the drive power supply.
8. Carry out a POWER ON (switch off the Control Unit and switch on again).
Wait until all LEDs on the drive are dark before switching on. Your settings become active after switching on.

Result:

You have configured the drive for communication via Ethernet/IP.

11.5.5 Supported objects

Overview

Object class		Object name	Objects required	SINAMICS objects
hex	dec			
1 hex	1	Identity object	x	-
4 hex	4	Assembly Object	x	-
6 hex	6	Connection Management Object	x	-
32C hex	812	Siemens Drive Object	-	x
32D hex	813	Siemens Motor Data Object	-	x
F5 hex	245	TCP/IP Interface Object ¹⁾	x	-
F6 hex	246	Ethernet Link Object ¹⁾	x	-
300 hex	768	Stack Diagnostic Object	-	x
302 hex	770	Adapter Diagnostic Object	-	x
303 hex	771	Explicit Messages Diagnostic Object	-	x
304 hex	772	Explicit Message Diagnostic List Object	-	x
401 hex	1025	Parameter object	-	x
402 hex ... 43E hex	1026...10 86	Parameter object	-	x

¹⁾ These objects are part of the Ethernet/IP system management.

For Assembly Object "4 hex" you define the data length. Assembly Object is assigned a cycle in the control system.

Identity Object, Instance Number: 1 hex

Supported services

- | | |
|---|---|
| <p>Class</p> <ul style="list-style-type: none"> • Get Attribute all • Get Attribute single | <p>Instance</p> <ul style="list-style-type: none"> • Get Attribute all • Get Attribute single • Reset |
|---|---|

Table 11- 37 Class Attribute

No.	Service	Type	Name
1	get	UINT16	Revision
2	get	UINT16	Max Instance
3	get	UINT16	Num of Instances

Table 11- 38 Instance Attribute

No.	Service	Type	Name	Value/explanation
1	get	UINT16	Vendor ID	1251
2	get	UINT16	Device Type - Siemens Drive	0C hex
3	get	UINT16	Product code	r0964[1]
4	get	UINT16	Revision	-
5	get	UINT16	Status	See the following table
6	get	UINT32	Serial number	Bit 0 ... 19: consecutive number; bits 20 ... 23: Production identifier bits 24 ... 27: Month of manufacture (0 = Jan, B = Dec) Bits 28 ... 31: Year of manufacture (0 = 2002)
7	get	Short String	Product name	max. length 32 byte

Table 11- 39 Explanation for No. 5 of the previous table

Byte	Bit	Name	Description
1	0	Owned	0: Inverter is not assigned to any master 1: Inverter is assigned to a master
	1	-	Reserved
	2	Configured	0: Ethernet/IP basic settings 1: Modified Ethernet/IP settings
	3	-	Reserved
2	4 ... 7	Extended Device Status	0: Self-test or status not known 1: Firmware update active 2: At least one I/O connection with error 3: No I/O connections 4: Incorrect configuration in the ROM 5: Fatal fault 6: At least one I/O connection is active 7: All I/O connections in the quiescent state 8 ... 15: Reserved
	8 ... 11	-	Not used
	12 ... 15	-	Reserved

Assembly Object, Instance Number: 4 hex**Supported services**

- | | | | |
|-------|--|----------|--|
| Class | <ul style="list-style-type: none"> • Get Attribute single | Instance | <ul style="list-style-type: none"> • Get Attribute single • Set Attribute single |
|-------|--|----------|--|

Table 11- 40 Class Attribute

No.	Service	Type	Name
1	get	UINT16	Revision
2	get	UINT16	Max Instance
3	get	UINT16	Num of Instances

Table 11- 41 Instance Attribute

No.	Service	Type	Name	Value/explanation
3	get	Array of UINT8	Assembly	1 byte array

Connection Management Object, Instance Number: 6 hex**Supported services**

- | | | | |
|-------|---|----------|---|
| Class | <ul style="list-style-type: none"> • Get Attribute all • Get Attribute single | Instance | <ul style="list-style-type: none"> • Forward open • Forward close • Get Attribute single • Set Attribute single |
|-------|---|----------|---|

Table 11- 42 Class Attribute

No.	Service	Type	Name
1	get	UINT16	Revision
2	get	UINT16	Max Instance
3	get	UINT16	Num of Instances

Table 11- 43 Instance Attribute

No.	Service	Type	Name	Value/explanation
1	get	UINT16	OpenReqs	Counters
2	get	UINT16	OpenFormat Rejects	Counters
3	get	UINT16	OpenResource Rejects	Counters
4	get	UINT16	OpenOther Rejects	Counters
5	get	UINT16	CloseReqs	Counters
6	get	UINT16	CloseFormat Rejects	Counters
7	get	UINT16	CloseOther Rejects	Counters
8	get	UINT16	ConnTimeouts	Counters Number of bus errors

Siemens Drive Object, Instance Number: 32C hex

Supported services

- | | | | |
|-------|--|----------|--|
| Class | <ul style="list-style-type: none"> • Get Attribute single | Instance | <ul style="list-style-type: none"> • Get Attribute single • Set Attribute single |
|-------|--|----------|--|

Table 11- 44 Class Attribute

No.	Service	Type	Name
1	get	UINT16	Revision
2	get	UINT16	Max Instance
3	get	UINT16	Num of Instances

Table 11- 45 Instance Attribute

No.	Service	Name	Value/explanation
2	get, set	Commissioning state	p0010 Commissioning, parameter filter
3 ... 18	get	STW1	STW1 bit-by-bit access: Attr.3 = STW1.0 Attr.18 = STW1.15
19	get	Main setpoint	Main setpoint
20 ... 35	get	ZSW1	ZSW1 bit-by-bit access: Attr.20 = ZSW1.0 Attr.35 = ZSW1.15
36	get	Actual Frequency	Main actual value (actual frequency)
37	get, set	Ramp Up Time	p1120[0] ramp-function generator ramp-up time
38	get, set	Ramp Down Time	p1121[0] ramp-function generator ramp-down time
39	get, set	Current Limit	p0640[0] current limit
40	get, set	Frequency MAX Limit	p1082[0] maximum speed
41	get, set	Frequency MIN Limit	p1080[0] minimum speed
42	get, set	OFF3 Ramp Down Time	p1135[0] OFF3 ramp-down time
43	get, set	PID Enable	p2200[0] technology controller enable
44	get, set	PID Filter Time Constant	p2265 Technology controller actual value filter time constant
45	get, set	PID D Gain	p2274 technology controller differentiation time constant
46	get, set	PID P Gain	p2280 Technology controller proportional gain
47	get, set	PID I Gain	P2285 Technology controller integral action time
48	get, set	PID Up Limit	p2291 technology controller maximum limiting

No.	Service	Name	Value/explanation
49	get, set	PID Down Limit	p2292 technology controller minimum limiting
50	get	Speed setpoint	r0020 speed setpoint
51	get	Output Frequency	r0024 output frequency
52	get	Output Voltage	r0025 output voltage
53	get	DC Link Voltage	r0026[0] DC link voltage
54	get	Actual Current	r0027 current actual value
55	get	Actual Torque	r0031 torque actual value
56	get	Output power	r0032 actual active power value
57	get	Motor Temperature	r0035[0] motor temperature
58	get	Power Unit Temperature	r0037[0] power unit temperature
59	get	Energy kWh	r0039 energy indicator
60	get	CDS Eff (Local Mode)	r0050 active command data set
61	get	Status Word 2	r2089[1] status word 2
62	get	Control Word 1	r0898 control word 1
63	get	Motor Speed (Encoder)	r0061 speed actual value
64	get	Digital Inputs	r0722 digital inputs status
65	get	Digital Outputs	r0747 digital outputs status
66	get	Analog Input 1	r0752[0] analog input 1
67	get	Analog Input 2	r0752[1] analog input 2
68	get	Analog Output 1	r0774[0] analog output 1
69	get	Analog Output 2	r0774[1] analog output 2
70	get	Fault Code 1	r0947[0] fault number 1
71	get	Fault Code 2	r0947[1] fault number 2
72	get	Fault Code 3	r0947[2] fault number 3
73	get	Fault Code 4	r0947[3] fault number 4
74	get	Fault Code 5	r0947[4] fault number 5
75	get	Fault Code 6	r0947[5] fault number 6
76	get	Fault Code 7	r0947[6] fault number 7
77	get	Fault Code 8	r0947[7] fault number 8
78	get	Pulse Frequency	r1801 actual pulse frequency
79	get	Alarm Code 1	r2110[0] alarm number 1
80	get	Alarm Code 2	r2110[1] alarm number 2
81	get	Alarm Code 3	r2110[2] alarm number 3
82	get	Alarm Code 4	r2110[3] alarm number 4
83	get	PID setpoint Output	r2260 technology controller setpoint after the ramp-function generator
84	get	PID Feedback	r2266 technology controller actual value after the filter
85	get	PID Output	r2294 technology controller output signal

The instances are assigned using the slot sequence in p0978.

Siemens Motor Data Object, Instance Number: 32D hex

Supported services

- | | | | |
|-------|--|----------|--|
| Class | <ul style="list-style-type: none"> • Get Attribute single | Instance | <ul style="list-style-type: none"> • Get Attribute single • Set Attribute single |
|-------|--|----------|--|

Object "32D hex" is only available on "SERVO" and "VECTOR" drive objects:

- SERVO DO = 11
- VECTOR DO = 12

Table 11- 46 Class Attribute

No.	Service	Type	Name
1	get	UINT16	Revision
2	get	UINT16	Max Instance
3	get	UINT16	Num of Instances

Table 11- 47 Instance Attribute

No.	Service	Type	Name	Value/explanation
2	get, set	UINT16	Commissioning state	p0010 commissioning parameter filter
3	get	INT16	Motor Type	p0300 motor type
6	get, set	REAL	Rated Current	p0305 rated motor current
7	get, set	REAL	Rated Voltage	p0304 rated motor voltage
8	get, set	REAL	Rated Power	p0307 rated motor power
9	get, set	REAL	Rated Frequency	p0310 rated motor frequency
10	get, set	REAL	Rated Temperature	p0605 threshold and temperature value for monitoring the motor temperature
11	get, set	REAL	Max Speed	p0322 maximum motor speed
12	get, set	UINT16	Pole pair number	p0314 motor pole pair number
13	get, set	REAL	Torque Constant	p0316 motor torque constant
14	get, set	REAL	Inertia	p0341 motor moment of inertia
15	get, set	REAL	Base Speed	p0311 rated motor speed
19	get, set	REAL	Cos Phi	p0308 rated motor power factor

The instances are assigned using the slot sequence in p0978.

TCP/IP Interface Object, Instance Number: F5 hex

Supported services

- | | | | |
|-------|---|----------|---|
| Class | <ul style="list-style-type: none"> • Get Attribute all • Get Attribute single | Instance | <ul style="list-style-type: none"> • Get Attribute all • Get Attribute single • Set Attribute single |
|-------|---|----------|---|

Table 11- 48 Class Attribute

No.	Service	Type	Name
1	get	UINT16	Revision
2	get	UINT16	Max Instance
3	get	UINT16	Num of Instances

Table 11- 49 Instance Attribute

No.	Service	Type	Name	Value/explanation
1	get	UNIT32	Status	Fixed value: 1 hex 1: Configuration acknowledged, by DHCP or saved values
2	get	UNIT32	Configuration Capability	Fixed value: 94 hex 4 hex: DHCP supported, 10 hex: Configuration can be adjusted, 80 hex: ACD-capable
3	get, set	UNIT32	Configuration Control	1 hex: Saved values 3 hex: DHCP
4	get, set	UNIT16	Path Size (in WORDs)	Fixed value: 2 hex
		UNIT8	Path	20 hex, F6 hex, 24 hex, 05 hex, where 5 hex is the number of instances of F6 hex (four physical ports plus one internal port).
5	get, set	STRING	Interface Configuration	r61000 Name of Station
		UNIT32		r61001 IP address
6	get, set	UNIT16	Host Name	Host Name Length
		STRING		-
10	get, set	UNIT8	Select ACD	local OM flash: 0: Disabled, 1: Enabled
11	get, set	UNIT8	Last Conflict Detected	local OM flash ACD Activity
		UNIT8		local OM flash Remote MAC
		UNIT8		local OM flash ARP PDU

Link Object, Instance Number: F6 hex

Supported services

- | | |
|---|--|
| <p>Class</p> <ul style="list-style-type: none"> • Get Attribute all • Get Attribute single | <p>Instance</p> <ul style="list-style-type: none"> • Get Attribute all • Get Attribute single • Set Attribute single |
|---|--|

Table 11- 50 Class Attribute

No.	Service	Type	Name
1	get	UINT16	Revision
2	get	UINT16	Max Instance
3	get	UINT16	Num of Instances

Table 11- 51 Instance Attribute

No.	Service	Type	Name	Value/explanation
1	get	UINT32	Interface Speed	0: link down, 10: 10 Mbps, 100: 100 Mbps
2	get	-	Interface Flags	Bit 1: Link-Status Bit 2: Duplex Mode (0: halb duplex, 1 duplex) Bit 3 ... 5: Automatic state identification Bit 6: Reset required Bit 7: Local hardware fault (0 = ok)
3	get	ARRAY	Physical Address	r8935 Ethernet MAC address
4	get, get_and_ clear	Struct of	Interface Counters	Optional, required if the "Media Counters Attribute" is implemented.
		UINT32	In Octets	Received octets
		UINT32	In Ucast Packets	Received Unicast packets
		UINT32	In NUcast Packets	Received non-Unicast packets
		UINT32	In Discards	Incoming packets, not processed
		UINT32	In Errors	Incoming packets with errors
		UINT32	In Unknown Protos	Incoming packets with unknown protocol
		UINT32	Out Octets	Sent octets
		UINT32	Out Ucast Packets	Sent Unicast packets
		UINT32	Out NUcast packets	Sent non-Unicast packets
		UINT32	Out Discards	Outgoing packets, not processed
UINT32	Out Errors	Outgoing packets, with errors		
5	get,	Struct of	Media Counters	Media-specific counters

No.	Service	Type	Name	Value/explanation
	get_and_clear	UINT32	Alignment Errors	Structure received, which does not match the number of octets
		UINT32	FCS Errors	Structure received, which does not pass the FCS check
		UINT32	Single Collisions	Structure successfully transmitted, precisely one collision
		UINT32	Multiple Collisions	Structure successfully transmitted, several collisions
		UINT32	SQE Test Errors	Number of SQE errors
		UINT32	Deferred Transmissions	First transmission attempt delayed
		UINT32	Late Collisions	Number of collisions that occurred delayed by 512 bit timers to the request
		UINT32	Excessive Collisions	Transmission unsuccessful as a result of intensive collisions
		UINT32	MAC Transmit Errors	Transmission unsuccessful as a result of an internal MAC sublayer transmission error.
		UINT32	Carrier Sense Errors	Number of errors when attempting to send a request frame, where the transmission condition was lost or was not assigned
		UINT32	Frame Too Long	Structure too large
		UINT32	MAC Receive Errors	Transmission unsuccessful as a result of an internal MAC sublayer receive error.
6	get, set	Struct of	Interface Control	-
		UINT16	Control Bits	-
		UINT16	Forced Interface Speed	-
10	get	String	Interface_Label	Interface-Label

Parameter Object, Instance Number: 401 hex

Supported services

Class • Get Attribute all

Instance • Get Attribute all
 • Set Attribute single

Table 11- 52 Class Attribute

No.	Service	Type	Name
1	get	UINT16	Revision
2	get	UINT16	Max Instance
3	get	UINT16	Num of Instances

Parameter access to drive object 0 (DO 0) is realized via this class.

Example: Read parameter 2050[10] (connector output to interconnect the PZD received from the fieldbus controller)

Get Attribute single function with the following values:

- Class = 401 hex
- Instance = 2050 = 802 hex \triangleq parameter number
- Attribute = 10 = A hex \triangleq Index 10

Example: Parameter 1520[0] writing (upper torque limit)

Set Attribute single function with the following values:

- Class = 401 hex
- Instance = 1520 = 5F0 hex \triangleq parameter number
- Attribute = 0 = 0 hex \triangleq index 0
- Data = 500.0 (value)

Parameter Object, Instance Number: 401 hex ... 43E hex

Supported services

Class

- Get Attribute All
- Get Attribute Single

Instance

- Get Attribute Single
- Set Attribute Single

Table 11- 53 Class Attribute

No.	Service	Type	Name
1	get	UINT16	-
2	get	UINT16	Max slot num
3	get	UINT16	Max slot ID

Parameter access to drive object 0 (DO 0) is realized via this class.

The class structure is analog to 401 hex. Drive object (DO) is selected via the class number.

Example:

0x401 -> DO 1

0x402 -> DO 2

...

0x43E -> DO 62

11.5.6 Integrate the drive device into the Ethernet network via DHCP

Integrating the drive into an Ethernet network

Proceed as follows to integrate the drive into Ethernet:

1. Set p8944 (CBE2x DHCP mode) = 2 or 3.
 - p8944 = 2: The DHCP server assigns the IP address based on the MAC address.
 - p8944 = 3: The DHCP server assigns the IP address based on the station name.
2. Save the settings with p8945 = 2.

When it is switched on the next time, the drive retrieves the IP address made available by a DHCP. You can address the drive as Ethernet node.

This means that you have integrated the drive into Ethernet

Displays

- r8950: Station name of the CBE20
- r8954: DHCP mode of the CBE20
- r8955: MAC address of the CBE20

11.5.7 Messages and parameters

Faults and alarms (see SINAMICS S120/S150 List Manual)

- F08501 PN/COMM BOARD: Setpoint timeout
- A08526 PN/COMM BOARD: No cyclic connection
- A50011 EtherNetIP/COMM BOARD: Configuration error

Overview of important parameters (see SINAMICS S120/S150 List Manual)

- p0978[0...n] List of drive objects
- p0922 IF1 PROFIdrive PZD telegram selection
- p0999[0...99] List of modified parameters 10
- p8835 CBE20 firmware selection
- p8842 COMM BOARD activate send configuration
- p8940[0...239] CBE2x Name of Station
- p8941[0...3] CBE2x IP address
- p8942[0...3] CBE2x Default Gateway
- p8943[0...3] CBE2x Subnet Mask
- p8944 CBE2x DHCP mode
- p8945 CBE2x interfaces configuration
- r8950[0...239] CBE2x Name of Station actual
- r8951[0...3] CBE2x IP address actual
- r8952[0...3] CBE2x Default Gateway actual
- r8954 CBE2x DHCP Mode actual
- r8955[0...5] CBE2x MAC address

11.6 Communication via SINAMICS Link

11.6.1 Basic principles of SINAMICS Link

A drive unit (with a node number) most frequently comprises a Control Unit with a number of connected drive objects (DOs). SINAMICS Link allows data to be directly exchanged between up to 64 CU320-2 PN or CU320-2 DP Control Units or CUD. All of the participating Control Units must be equipped with a CBE20 in order that SINAMICS Link functions. Possible applications are, for example:

- Torque distribution for n drives
- Setpoint cascading for n drives
- Load distribution of drives coupled through a material web
- Master/slave function for infeed units
- Links between SINAMICS DC-MASTER and SINAMICS S120

Requirements

The following preconditions must be fulfilled to operate SINAMICS Link:

- r0108.31: Function module "PROFINET CBE20" must be activated for each drive object.
- r2064[1]: The bus cycle time (T_{dp}) must be an integer multiple of p0115[0] (current controller cycle).
- r2064[2]: The master cycle time (T_{mapc}) must be an integer multiple of p0115[1] (speed control cycle).
- The current controller cycle must be set to 250 μ s or 500 μ s. One clock with 400 μ s is not permitted. For 400 μ s, alarm A01902[4] is output. As countermeasure, set the current controller cycle with p0115[0] to 500 μ s.

Note

The "SINAMICS Link" function is not available for the Control Unit CU310-2.

Note

SINAMICS Link for chassis format

For the following devices in the chassis format, you must set parameter p0115[0] to 250 μ s or 500 μ s:

- 380 - 480 V 3-phase AC: All devices with rated current index ≥ 605 A
 - 500 - 690 V 3-phase AC: All devices
-

Send and receive data

The SINAMICS Link telegram contains 32 indices (0...31) for the process data (PZD1...32). Each PZD is precisely 1 word long (= 16 bits). Indices that are not required are automatically filled with zeros. There is always a fixed assignment between the index and PZD: The index *i* corresponds to PZD *i*+1.

Index	0	1	2	3	4	5	6	7	8	9	10	11	12	13	14	15
PZD	1	2	3	4	5	6	7	8	9	10	11	12	13	14	15	16

SINAMICS Link telegram content, Part 1

Index	16	17	18	19	20	21	22	23	24	25	26	27	28	29	30	31
PZD	17	18	19	20	21	22	23	24	25	26	27	28	29	30	31	32

SINAMICS Link telegram content, Part 2

Each transfer cycle, every SINAMICS Link node can send 1 telegram with 32 PZD. Each node receives all of the telegrams that are sent. For each transfer cycle clock, a node can select and process up to 32 PZD from all telegrams that have been received. Single words and double words can be sent and received. You must write double words in two consecutive PZDs.

Limitations:

- In a telegram, a PZD may only be sent and received once. If a PZD occurs more than once in a telegram, then Alarm A50002 or A50003 is output.
- It is not possible to read in your own send data. SINAMICS S then initiates the corresponding alarms. The following alarms are possible:
 - A50006: It is parameterized that own data sent can be received. This is not permitted.
 - A50007: The send telegram word is larger than possible in the project.
 - A50008: The receive telegram word is larger than possible in the project.
- The maximum number of PZDs that can be received and sent also depends on the drive object. The number of PZDs that can be evaluated corresponds to communication according to PROFIdrive; however, for SINAMICS Link, it is limited to a maximum of 32 PZDs.
- If, as a result of a project download, parameters of the CBE20 are change, then alarm A08531 is output. In this case, a POWER ON is required to activate the values.

Transmission time

With SINAMICS Link, a transmission time of up to 500 µs is possible (with a max. controller cycle of 500 µs; synchronous bus cycle of 500 µs).

Bus cycle and number of nodes

You can operate the bus cycle of the SINAMICS Link with the current controller cycle, either synchronized or non-synchronized.

- Synchronized operation is set with $p8812[0] = 1$. A maximum of 16 nodes can then communicate with one another via SINAMICS Link. To do so, set the maximum number of nodes with $p8811 = 16$.
- In the non-synchronized mode, the bus cycle of the SINAMICS Link can be set with $p8812[1]$ to 1000 μs or 2000 μs . Then, via $p8811$, a maximum of 64 nodes can communicate via SINAMICS Link.

After changing parameter $p8811$, $p8812$, $p8835$ or $p8836$, carry out a POWER ON to transfer the settings.

11.6.2 Topology

Only a line topology with the following structure is permitted for SINAMICS Link. You must manually set the parameters in the expert lists of the Control Units and drive objects. To do this, use the STARTER commissioning tool.

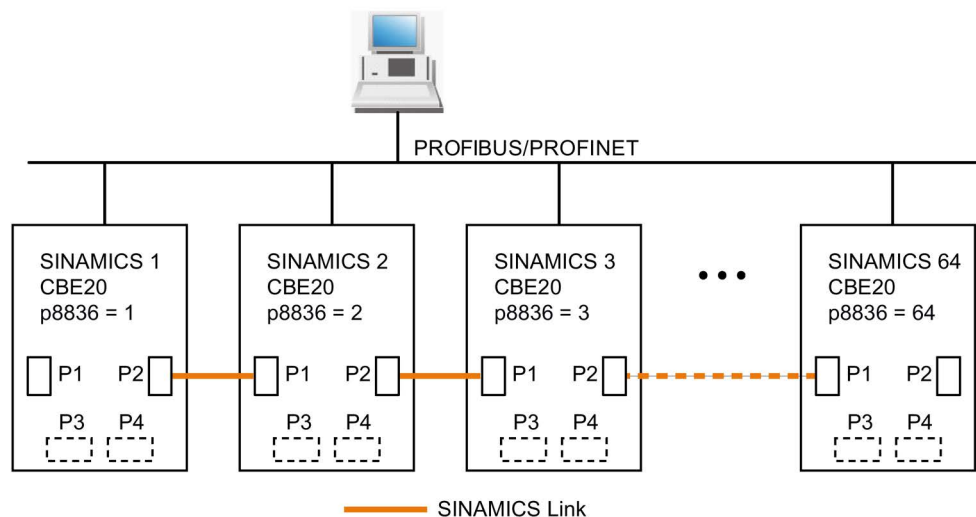

Figure 11-54 Maximum topology

Features

- The CBE20 can be assigned to IF1 or IF2 when SINAMICS Link is used.
The interface, assigned to the CBE20, must be switched into synchronous operation.
You must also make the following parameter settings in order to assign, e.g. IF1 to SINAMICS Link:
 - For IF1: p8839[0] = 2 (COMM BOARD)
 - For IF2: p8839[1] = 1 (Control Unit onboard)The data in the additional description are applicable for the case (IF1 \neq SINAMICS Link).
- The number of the respective node must be entered manually in parameter p8836. Each node must be assigned a different number. Enter the numbers in ascending order starting with 1.
- If p8836 is set to 0, the nodes and the complete following line is shut down for SINAMICS Link.
- Gaps in the numbering are not permitted, as then SINAMICS Link would not function.
- The associated IP addresses are assigned automatically, but are however not visible.
- The node with the number 1 is automatically the sync master of the communication link.
- A maximum of 64 nodes are possible for a communication cycle between 1000 μ s and 2000 μ s.
- 8, 12 or a maximum of 16 nodes are possible in the isochronous mode at 500 μ s.
- The ports of the CBE20 must be interconnected strictly in accordance with the above diagram. You must always connect port 2 (P2) of node n with port 1 (P1) of node n + 1.
- In the "SINAMICS Link" mode, ports 3 and 4 of the CBE20 can only be used in conjunction with the STARTER commissioning tool.

Corresponding parameters for IF1 or IF2

Use different parameters for configuring, depending on which interface SINAMICS Link is assigned:

Table 11- 54 Corresponding parameters

Parameters	IF1	IF2
Setting of the processing mode for PROFIdrive STW1.10 "Control by PLC".	p2037	p8837
Connector output to interconnect the PZD (setpoints) received from the fieldbus controller in the word format.	r2050	r8850
Selects the PZD (actual values) to be sent to the fieldbus controller in the word format.	p2051	p8851
Displays the PZD (actual values) sent to the fieldbus controller in the word format.	r2053	r8853
Connector output to interconnect the PZD (setpoints) received from the fieldbus controller in the double word format.	r2060	r8860
Selects the PZD (actual values) to be sent to the fieldbus controller in the double word format.	p2061	p8861
Displays the PZD (actual values) sent to the fieldbus controller in the double word format.	r2063	r8863

11.6.3 Configuring and commissioning

Commissioning

When commissioning, proceed as follows:

1. Set the Control Unit parameter p0009 = 1 (device configuration).
2. Set the Control Unit parameter p8835 = 3 (SINAMICS Link).
3. Using p8839, define which interface should be used (for example for IF1: p8839[0] = 2).
4. If SINAMICS Link is assigned to IF1, set parameter p2037 of the drive objects to 2 (do not freeze setpoints).

If SINAMICS Link was assigned IF2, then p8837 must be used for the setting.

5. Assign the nodes in parameter p8836 to the SINAMICS Link node number.

The first Control Unit is always assigned the number 1. Node number 0 means that for this Control Unit SINAMICS Link has been shut down. Observe the specifications under "Topology".

6. Set the Control Unit parameter p0009 = 0 (ready).
7. Execute a "Copy RAM to ROM".
8. Carry out a POWER ON (switch off the Control Unit and switch on again).

Sending data

Note

The parameters listed in the following description refer to the assignment of SINAMICS Link to IF1. If you assigned SINAMICS Link to IF2, then you find the corresponding parameters in the "Table 11-54 Corresponding parameters (Page 867)".

In this example, the first "Control Unit 1" node has two drive objects: "Drive 1" and "Drive 2". Proceed as follows to send data:

1. If SINAMICS Link is assigned to IF1, then for each drive object, in its associated parameter p2051[0...31], you define which data (PZDs) should be sent.
 If SINAMICS Link was assigned IF2, then p8851 must be used for the setting. The data is simultaneously reserved in the send slot of the p8871[0...31].
2. Enter the double words in p2061[x].
 Double word data is simultaneously written to p8861[0...31].
3. For each drive object, allocate the send parameters in p8871[0...31] to a send slot of its own node.

Table 11- 55 Compile send data of drive 1 (DO2)

p2051[x] Index	p2061[x] Index	Contents	From parameter	Slots in the send buffer p8871[x]	
				x	Telegram word
0	-	ZSW1	r0899	0	1
-	1	Actual speed value part 1	r0061[0]	1	2
-		Actual speed value part 2		2	3
-	3	Actual torque value part 1	r0080	3	4
-		Actual torque value part 2		4	5
5	-	Actual fault code	r2131	5	6
6	-	0	0	6	0
...	-	...	-
15	-	0	0	15	0
...	-	...	-
31	-	0	0	31	0

Table 11- 56 Compile send data of drive 2 (DO3)

p2051[x] Index	p2061[x] Index	Contents	From pa- rameter	Slots in the send buffer p8871[x]	
				x	Telegram word
-	-	-	-	0...5 ¹⁾	0
0	-	ZSW1	r0899	6	7
-	1	Actual speed value part 1	r0061[0]	7	8
-		Actual speed value part 2		8	9
-	3	Actual torque value part 1	r0080	9	10
-		Actual torque value part 2		10	11
5	-	Actual fault code	r2131	11	12
6	-	0	0	12	0
...	
15	-	0	0	15	0
...	-	...	-
31	-	0	0	31	0

¹⁾ 0...5 here remain free, as they are already assigned by DO2.

Table 11- 57 Compile send data of Control Unit 1 (DO1)

p2051[x] Index	p2061[x] Index	Contents	From pa- rameter	Slots in the send buffer p8871[x]	
				x	Telegram word
-	-	-	-	0...11 ²⁾	0
0	-	Control word, faults/alarms	r2138	12	13
-	1	Missing enables part 1	r0046	13	14
-		Missing enables part 2		14	15
15	-	0	0	15	0
...	-	...	-
31	-	0	0	31	0

²⁾ 0...11 here remain free, as they are already assigned by DO2 and DO3.

Send slots PZD 16 to 31 are not required for this telegram and are therefore filled with a zero.

- For double words (e.g. 1 + 2), assign two consecutive send slots, e.g. p2061[1] => p8871[1] = PZD 2 and p8871[2] = PZD 3.
- Enter the following PZD into the next parameter slots of p2051[x] or p2061[2x].
- You must fill the unused slots of p8871[0...31] with zeros.
- The sequence of the PZDs in the send telegram of this node are defined in parameter p8871[0...31] by the entries in the required slots.

Receiving data

The sent telegrams of all nodes are simultaneously available at the SINAMICS Link. Each telegram has a length of 32 PZD. Each telegram has a marker of the sender. You select those PZD that you want to receive for the relevant node from all telegrams. You can process a maximum of 32 PZD.

Note

If you have not deactivated the evaluation of bit 10 with p2037 = 2, the first word of the receive data (PZD 1) must be a control word, where bit 10 = 1 is set.

In this example, Control Unit 2 receives selected data from the telegram of Control Unit 1. Proceed as follows to receive data:

1. In parameter p8872[0...31] enter the address of the node for which you want to read one or more PZDs (e.g. p8872[3] = 1 → from node 1, read in PZD 4, p8872[15] = 0 → do not read in PZD 16).
2. After setting the parameters, using parameter r2050[0...31] or r2060[0...31] you can read out the values.

Table 11- 58 Receive data for Control Unit 2

From the sender		Receiver					
Transfer from	Tel. word ¹⁾ p8871[x]	Address p8872[x]	Receive buffer p8870[x]	Data transferred in		Parameter	Contents
				r2050[x]	r2060[x]		
p2051[0]	0	1	PZD 1	0	-	r0899	ZSW1
p2061[1]	1	1	PZD 2	-	1	r0061[0]	Actual speed value part 1
	2	1	PZD 3	-		r0061[0]	Actual speed value part 2
p2061[3]	3	1	PZD 4	-	3	r0080	Actual torque value part 1
	4	1	PZD 5	-			Actual torque value part 2
p2051[5]	5	1	PZD 6	5	-	r2131	Actual fault code
p2051[4]	6	1	PZD 7	6	-	r0899	ZSW1
p2061[5]	7	1	PZD 8	-	7	r0061[0]	Actual speed value part 1
	8	1	PZD 9	-			Actual speed value part 2
p2061[6]	9	1	PZD 10	-	9	r0080	Actual torque value part 1
	10	1	PZD 11	-			Actual torque value part 2
p2051[7]	11	1	PZD 12	11	-	r2131	Actual fault code
p2051[8]	12	1	PZD 13	12	-	r2138	Control word, faults/alarms
p2061[9]	13	1	PZD 14	-	13	r0046	Missing enables part 1
	14	1	PZD 15	-			Missing enables part 2
-	15	0	PZD 16	15	-	0	Empty
...
-	31	0	PZD 32	31	0	0	-

1) Tel.word = telegram word

Note

For double words, two PZD must be read in succession. To do this, read in a 32 bit setpoint, which is on PZD 2 + PZD 3 of the telegram of node 2. Emulate this setpoint on PZD 2 + PZD 3 of node 1: p8872[1] = 2, p8870[1] = 2, p8872[2] = 2, p8870[2] = 3

Activating the SINAMICS Link

To activate SINAMICS Link connections, perform a POWER ON for all nodes.

The assignments of p2051[x]/2061[2x] and the links of the read parameters r2050[x]/2060[2x] can be changed without a POWER ON.

11.6.4 Example**Task**

Configure SINAMICS Link for two nodes and transfer the following values:

- Send data from node 1 to node 2
 - r0898 CO/BO: Control word, sequence control, drive 1 (1 PZD), in the example PZD 1
 - r0079 CO: Total torque setpoint (2 PZD), in the example PZD 2
 - r0021 CO: Smoothed actual speed (2 PZD), in the example PZD 3
- Send data from node 2 to node 1
 - r0899 CO/BO: Status word, sequence control, drive 2 (1 PZD), in the example PZD 1
- IF1 is used for SINAMICS Link.

Procedure

1. For all nodes, set p0009 = 1 to change the device configuration.
2. For all CBE20 nodes, set the "SINAMICS Link" mode using p8835 = 3.
3. Limit the maximum number of nodes for all nodes with p8811 = 8. By setting p8811, parameter p8812[1] is preassigned, and parameter p8836, if necessary, is corrected.
4. Assign the node numbers for the devices involved:
 - Node 1 (≙ device 1): p8836 = 1
 - Node 2 (≙ device 2): p8836 = 2
5. Set all CBE20 to the isochronous mode by setting p8812[0] = 1.
6. Make the following interface setting for all nodes:
 - For IF1: p8839[0] = 2 (COMM BOARD)
 - For IF2: p8839[1] = 1 (Control Unit onboard)

7. For both nodes p0009 = 0, carry out a "Copy RAM to ROM" followed by a POWER ON in order to activate the modified firmware versions and the new settings in the CBE20.
8. Define the send data for node 1:
 - Define the PZD that node 1 should send:
 - p2051[0] = drive 1:r0898 (PZD 1)
 - p2061[1] = drive1:r0079 (PZD 2 + PZD 3)
 - p2061[3] = drive1:r0021 (PZD 4 + PZD 5)
 - Place these PZD in the send buffer (p8871) of node 1:
 - p8871[0] = 1 (r0898)
 - p8871[1] = 2 (r0079 1st part)
 - p8871[2] = 3 (r0079 2nd part)
 - p8871[3] = 4 (r0021 1st part)
 - p8871[4] = 5 (r0021 2nd part)
9. Define the receive data for node 2:
 - Specify that the data placed in the receive buffer p8872 of node 2 in locations 0 to 4 will be received by node 1:
 - p8872[0] = 1
 - p8872[1] = 1
 - p8872[2] = 1
 - p8872[3] = 1
 - p8872[4] = 1
 - Specify that PZD1, PZD2, and PZD3 of node 1 will be placed in the receive buffer p8870 of node 2 in locations 0 to 4:
 - p8870[0] = 1 (PZD1)
 - p8870[1] = 2 (PZD2 1st part)
 - p8870[2] = 3 (PZD2 2nd part)
 - p8870[3] = 4 (PZD3 1st part)
 - p8870[4] = 5 (PZD3 2nd part)
 - r2050[0], r2060[1] and r2060[3] subsequently contain (after step 13) the values of PZD 1, PZD 2 and PZD 3 of node 1.
10. Define the send data for node 2:
 - Specify the PZD that node 2 should send:
 - p2051[0] = drive1:r0899 (PZD length is 1 word)
 - Place this PZD in the send buffer (p8871) of node 2:
 - p8871[0] = 1
11. Define the receive data for node 1:
 - Specify the data that should be placed in the receive buffer p8872 of node 1 in location 0, received from node 2:
 - p8872[0] = 2
 - Define that PZD1 of node 2 is saved in the receive buffer p8870 of node 1 in location 0:
 - p8870 [0] = 1
 - r2050[0] subsequently contains (after step 13) the value of PZD 1 of node 2.

12. At the two nodes carry-out a "Copy RAM to ROM" to backup the parameterization and the data.

13. Set p8842 = 1, to activate parameters p8870, p8871 and p8872.

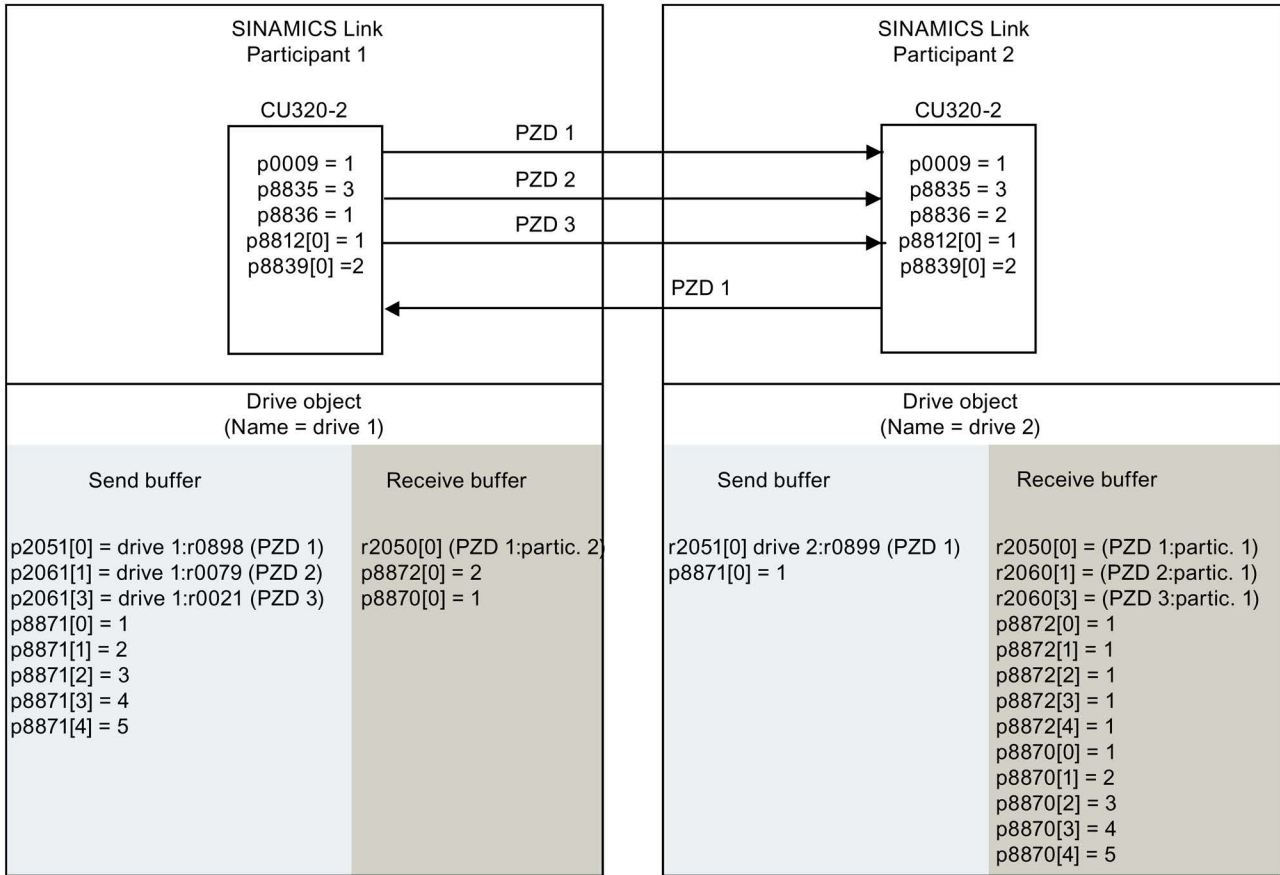

Figure 11-55 SINAMICS Link: Configuration example

11.6.5 Communication failure when booting or in cyclic operation

If at least one sender does not correctly boot after commissioning or fails in cyclic operation, then alarm A50005 is output to the other nodes: "Sender was not found on the SINAMICS Link."

The message contains the number of the faulted node. After you have resolved the fault at the node involved and the system has identified the node, the system automatically withdraws the alarm.

If several nodes are involved, the message occurs a multiple number of times consecutively with different node numbers. After you have resolved all of the faults, the system automatically withdraws the alarm.

When a node fails in cyclic operation, in addition to alarm A50005, fault F08501 is output: "COMM BOARD: Monitoring time, process data expired"

11.6.6 Examples: Transmission times for SINAMICS Link

Example 1: Transmission times at a communication cycle of 1 ms

p2048 or p8848 = 1 ms

Bus cycle	Transmission time			
	Sync both	Sync send	Sync receive	Async both
0.5	1.0	1.5	1.3	1.6
1.0	1.5	2.1	2.1	2.2
2.0	3.0	3.6	3.1	2.8

Example 2: Transmission times at a communication cycle of 4 ms

p2048 or p8848 = 4 ms

Bus cycle	Transmission time			
	Sync both	Sync send	Sync receive	Async both
0.5	1.0	3.0	2.8	4.6
1.0	1.5	3.6	3.6	5.2
2.0	3.0	5.1	4.6	5.8

11.6.7 Function diagrams and parameters

Function diagrams (see SINAMICS S120/S150 List Manual)

- 2197 Control Unit communication - SINAMICS Link overview (r0108.31 = 1, p8835 = 3)
- 2198 Control Unit communication - SINAMICS Link configuration (r0108.31 = 1, p8835 = 3)
- 2199 Control Unit communication - SINAMICS Link receive data (r0108.31 = 1, p8835 = 3)
- 2200 Control Unit communication - SINAMICS Link send data (r0108.31 = 1, p8835 = 3)

Overview of important parameters (see SINAMICS S120/S150 List Manual)

- r0108.31: Drive object function module
PROFINET CBE20
- p0115[0] Sampling time for additional functions
- p2037 IF1 PROFIdrive STW1.10 = 0 mode
- r2050[0...31] CO: IF1 PROFIdrive PZD receive word
- p2051[0...31] CI: IF1 PROFIdrive PZD send word
- r2060[0...30] CO: IF1 PROFIdrive PZD receive double word
- p2061[0...30] CI: IF1 PROFIdrive PZD send double word
- p8811 SINAMICS Link project selection
- p8812[0...1] SINAMICS Link cycle settings
- p8835 CBE20 firmware selection
- p8836 SINAMICS Link node address
- p8839[0...1] PZD interface hardware assignment
- p8870[0...31] SINAMICS Link PZD receive word
- p8871[0...31] SINAMICS Link PZD send word
- p8872[0...31] SINAMICS Link PZD receive address

11.7 Communication services and used port numbers

SINAMICS supports the protocols listed in the table below. The address parameters, the relevant communication layer as well as the communication role and the communication direction are specified for each protocol.

This information allows you to match the security measures for the protection of the automation system to the used protocols (e.g. firewall). As the security measures are limited to Ethernet and PROFINET networks, no PROFIBUS protocols are listed in the table.

The following table shows the various layers and protocols that are used.

Layers and protocols

Report	Port number	(2) Link layer (4) Transport layer	Function	Description
PROFINET protocols				
DCP Discovery and configuration protocol	Not relevant	(2) Ethernet II and IEEE 802.1Q and Ethertype 0x8892 (PROFINET)	Accessible nodes, PROFINET Discovery and configuration	DCP is used by PROFINET to determine PROFINET devices and to make basic settings. DCP uses the special multicast MAC address: xx-xx-xx-01-0E-CF, xx-xx-xx = Organizationally Unique Identifier
LLDP Link Layer Discovery protocol	Not relevant	(2) Ethernet II and IEEE 802.1Q and Ethertype 0x88CC (PROFINET)	PROFINET Link Layer Discovery protocol	LLDP is used by PROFINET to determine and manage neighborhood relationships between PROFINET devices. LLDP uses the special multicast MAC address: 01-80-C2-00-00-0E
MRP Media Redundancy Protocol	Not relevant	(2) Ethernet II and IEEE 802.1Q and Ethertype 0x88E3 (PROFINET)	PROFINET medium redundancy	MRP enables the control of redundant routes through a ring topology. MRP uses the special multicast MAC address: xx-xx-xx-01-15-4E, xx-xx-xx = Organizationally Unique Identifier

Report	Port number	(2) Link layer (4) Transport layer	Function	Description
PTCP Precision Transparent Clock Protocol	Not relevant	(2) Ethernet II and IEEE 802.1Q and Ethertype 0x8892 (PROFINET)	PROFINET send clock and time synchronisation, based on IEEE 1588	PTC enables a time delay measurement between RJ45 ports and therefore the send cycle synchronization and time synchronization. PTCP uses the special multicast MAC address: xx-xx-xx-01-0E-CF, xx-xx-xx = Organizationally Unique Identifier
PROFINET IO data	Not relevant	(2) Ethernet II and IEEE 802.1Q and Ethertype 0x8892 (PROFINET)	PROFINET Cyclic IO data transfer	The PROFINET IO telegrams are used to cyclically transfer I/O data between the PROFINET IO controller and IO devices via Ethernet.
PROFINET Context Manager	34964	(4) UDP	PROFINET connection less RPC	The PROFINET context manager provides an endpoint mapper in order to establish an application relationship (PROFINET AR).
Connection-oriented communication protocols				
FTP File transfer protocol	21	(4) TCP	Server/incoming	FTP can be used for the first commissioning. FTP can be activated/deactivated using parameter p8908.
DHCP Dynamic Host Configuration Protocol	68	(4) UDP	Dynamic Host Configuration Protocol	Is used to query an IP address. Is closed when delivered, and is opened when selecting the DHCP mode.
HTTP Hypertext transfer protocol	80	(4) TCP	Hypertext transfer protocol	HTTP is used for the communication with the CU internal Web server. Is open in the delivery state and can be deactivated.

11.7 Communication services and used port numbers

Report	Port number	(2) Link layer (4) Transport layer	Function	Description
ISO on TCP (according to RFC 1006)	102	(4) TCP	ISO-on-TCP protocol	ISO on TCP (according to RFC 1006) is used for the message-oriented data exchange to a remote CPU, WinAC or devices of other suppliers. Communication with ES, HMI, etc. Is open in the delivery state and is always required.
SNMP Simple network management protocol	161	(4) UDP	Simple network management protocol	SNMP enables the reading out and setting of network management data (SNMP managed Objects) by the SNMP manager. Is open in the delivery state and is always required.
HTTPS Secure Hypertext transfer protocol	443	(4) TCP	Secure Hypertext transfer protocol	HTTPS is used for the communication with the CPU internal Web server via Secure Socket Layer (SSL). Is open in the delivery state and can be deactivated.
Internal report	5188	(4) TCP	Server/incoming	Communication with STARTER for downloading project data.
Reserved	49152...65535	(4) TCP (4) UDP	-	Dynamic port area that is used for the active connection endpoint if the application does not specify the local port.

Report	Port number	(2) Link layer (4) Transport layer	Function	Description
EtherNet/IP protocols				
Explicit messaging	44818	(4) TCP (4) UDP	-	Is used for parameter access, etc. Is closed when delivered, and is opened when selecting EtherNet/IP.
Implicit messaging	2222	(4) UDP	-	Is used for exchanging I/O data. Is closed when delivered, and is opened when selecting EtherNet/IP.
Modbus TCP protocols (server)				
Request & Response	502	(4) TCP	-	Is used for exchanging data packages. Is closed when delivered, and is opened when selecting Modbus TCP.

11.8 Time synchronization between the control and converter

11.8.1 Description

In the factory setting, SINAMICS S120 drives use an operating hours counter. Based on the operating hours, SINAMICS S120 saves alarms and warnings that occur. Using this method, it is not possible to have a comparable timestamp between various converters.

In order to obtain a comparable timestamp between several converters, you must change over the operating hours counting to time in the UTC format and synchronize with the time master (control system).

This means that the events of all bus nodes, which are synchronized with the control system time, can be referenced with one another.

Benefits: Improved diagnostic options by having a comparable time stamp of the bus nodes involved.

Converters provide the following options to synchronize the time:

Synchronization type	Accuracy
Basic synchronization	approx. 100ms
Synchronization using ping compensation for non-isochronous communication	approx. 10 ms
Synchronization using ping compensation for isochronous communication	approx. 1 ms

Principle of operation of time synchronization

Basic synchronization

The control system transfers the time to the converter at time intervals that you specify in the control system. Transfer is realized acyclically in the UTC format. The converter accepts this time as soon as transfer has been completed without correcting the transfer duration. The converter logs alarms and warnings based on this time.

Time synchronization with ping compensation

At intervals that you specify in the control system, the control system sends a ping (a positive signal edge) cyclically to the converter. Simultaneously, in acyclic operation, the device sends the time in the UTC format in what is known as "snap".

As soon as the ping has been received in the drive, a timer starts which measures the time until the snap has been completely transferred. The drive accepts the time that the snap transfers. It then corrects it by the time that has expired between receiving the ping and the complete transfer of the snap.

If the snap has not been transferred within 5 s after receiving the ping, then this synchronization cycle is not used.

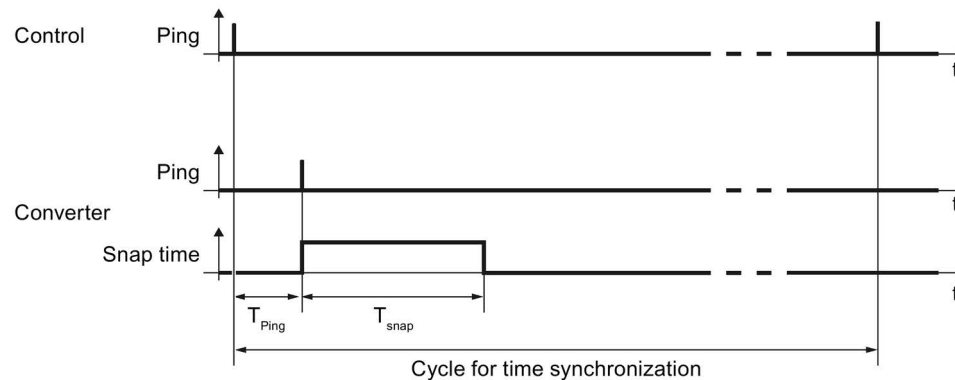

Figure 11-56 Ping snap

Differences for isochronous and non-isochronous communication:

Communication	Description
Isochronous	The ping compensation value is determined in the converter.
not isochronous	You can influence the accuracy of the ping compensation using the PZD sampling time (p2048).

11.8.2 Settings

Setting time synchronization

1. Using p3100, changeover the time format from operating hours into the UTC format (see "Changing the time format").
2. Set the synchronization technique:
 - Basic synchronization (p3103 = 2)
 - Time synchronization with ping compensation (p3103 = 0)
3. Using p3104, set the ping source:
 - If you are working with one of the telegrams 390, 391 or 392, then the source of the ping (p3104) is internally connected with bit 1 of the CU control word (DO1:CU_STW.Bit1). In this case, parameter p3104 is blocked.
 - If you are using a free telegram (999), interconnect the ping source (p3104) via BICO in the control word.
 - If you are working with CANopen, interconnect a free bit in the CANopen control word with p3104 via a BICO connection.

Result:

After time synchronization, the actual time at drive object DO1 is obtained from the time transferred by the time master plus the delay time associated with the transfer (ping-snap time). This time stamp then applies to all of the drive objects involved

The actual UTC time is displayed in the drive system using r3102.

At certain intervals, synchronization (according to the same technique) is repeated (depending on the setting in the time master).

If a previously defined tolerance window is exceeded, then alarm A01099 is output. The tolerance window for time synchronization can be defined using p3109. If alarm A01099 occurs, then generally the synchronization interval is too large.

In this case, reduce the synchronization interval in your control system.

Changing the time format

The time format is entered via parameter p3100. This parameter cannot be changed online. To change the value, proceed as follows:

1. In STARTER, using the "Project > Connect to target system" function activate the ONLINE mode.
2. Upload using the "Target system> Load > Project to PG" function.
3. In STARTER, using the "Project > Disconnect connection to target device" function exit the ONLINE mode.
4. Offline, in the expert list of the control unit, make the setting p3100 = 1.
5. Reactivate the ONLINE mode.
6. Carry out a parameter download ("Target system > Load > Load project to target system") followed by copy from RAM to ROM.

You have now changed over the converter time format to UTC format.

Application example

In the SIEMENS "Industry Online Support", for a typical application example, you can find detailed documentation with solution strategies and matching code examples:

Time synchronization example

<https://support.industry.siemens.com/cs/de/en/view/88231134>

11.8.3 Messages and parameters

Faults and alarms (see SINAMICS S120/S150 List Manual)

- A01099 UTC synchronization tolerance violated

Overview of important parameters (see SINAMICS S120/S150 List Manual)

- p2048 IF1 PROFIdrive PZD sampling time
- p3100 RTC time stamp mode
- p3101[0...1] Set UTC time
- r3102[0...1] Display UTC time
- p3103 UTC synchronization technique
- p3104 BI: UTC PING synchronization
- r3107[0...3] UTC synchronization time out of tolerance
- r3108[0...1] UTC synchronization deviation
- p3109 UTC synchronization tolerance
- p3116 BI: Suppress automatic acknowledgment

12.1 Application examples

You can find SINAMICS application examples on the Internet page "SINAMICS application examples".

We can offer you efficient system strategies, especially as a result of the optimum interaction between SIMATIC control technology and SINAMICS drive systems.

The application examples provide you with:

- Reusable modules for scaling setpoints and actual values
- Explanation of the necessary configuring steps together with screenshots
- Security through already tested programs and modules for accessing parameters
- Significantly lower commissioning times
- Detailed documentation with parts lists of the hardware and software components being used

Further, you can also find technological application examples, such as winders, traversing arms and basic synchronous operation. These application examples also explain how to use free function blocks (FBLOCKS), logic processing integrated in the drive with Drive Control Chart (DCC) and Safety Integrated.

Finding and calling application examples

1. Call the following site in your Internet browser:

SINAMICS application examples (<https://www.automation.siemens.com/mc-app/sinamics-application-examples/Home/Index?language=en>)

2. Select the required filter in the search mask.

Example:

The screenshot shows a search mask with the following settings:

- DriveType: S120 [3]
- DriveFunction: Safety-control [3]
- Control: (empty)
- EngineeringEnvironment: (empty)
- Communication: PROFIBUS [3]
- Speciality: (empty)

A "Reset Filter" button is visible at the bottom right of the filter area.

The result list is updated every time a filter setting is specified.

Application	DriveType	DriveFunction	Control	EngineeringEnvironment	Communication	Speciality
> SINAMICS S: Safety-control of a S120 using S7-300/400 (STEP 7 V5) with PROFIBUS and Safety Integrated (via PROFIsafe)	S120	Safety-control	S7-300/400	STEP 7 V5	PROFIBUS	Safety Integrated
> SINAMICS S: Safety-control of a S120 using S7-300/400 (STEP 7 V5) with PROFIBUS and Safety Integrated (via TM54F)	S120	Safety-control	S7-300/400	STEP 7 V5	PROFIBUS	Safety Integrated
> SINAMICS S: Safety-control of a S120 using S7-300/400 (STEP 7 V5) with PROFINET (Shared Device) and Safety Integrated (via PROFIsafe)	S120	Safety-control	S7-300/400	STEP 7 V5	PROFIBUS PROFINET	Safety Integrated

Individual filters can be reset by clicking the X to the right of the filter. You can reset all filters simultaneously by clicking the "Reset filters" button.

3. The first details of the required application description can then be displayed in a tooltip. To do this, click the appropriate entry in the result list.

The required tooltip is then displayed in the Siemens Industry Online Support.

Entry type: Application example, Entry ID: 29056318, Entry date: 10/25/2011

☆☆☆☆ (0)
> Rate

SINAMICS S: Safety-control of a S120 using S7-300/400 (STEP 7 V5) with PROFIBUS and Safety Integrated (via PROFIsafe)

Entry Associated product(s)

Task

Extended safety functions which have been integrated in the SINAMICS S120 drives shall be activated via PROFIsafe with PROFIBUS. Both drives use different safety functions. The F-CPU is responsible for the safety-related logical processing of the input signal. The F-CPU acts as F master and as PROFIBUS master.

This functional example is based on the SINAMICS S120 training case (6ZB2480-0BA00) and the SAFETY training case.

This application gives you an example of how you can configure your communications.

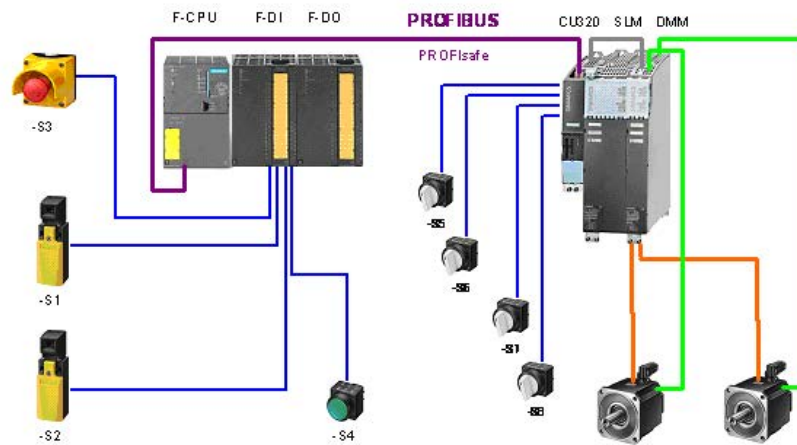

Downloads

Content of downloads	Version	Download

Generally, you can download a detailed application description as PDF via the tooltip.

12.2 Infeed switch on by a drive

Using this BICO interconnection, a drive object (DO) "X_INF" (= all drive objects "Infeed"; i.e.: A_INF, B_INF, S_INF) can be activated by a "SERVO/VECTOR" drive object. This switch-on version is mainly used for drive units in the "chassis" format if a single Infeed Module and a Motor Module are used.

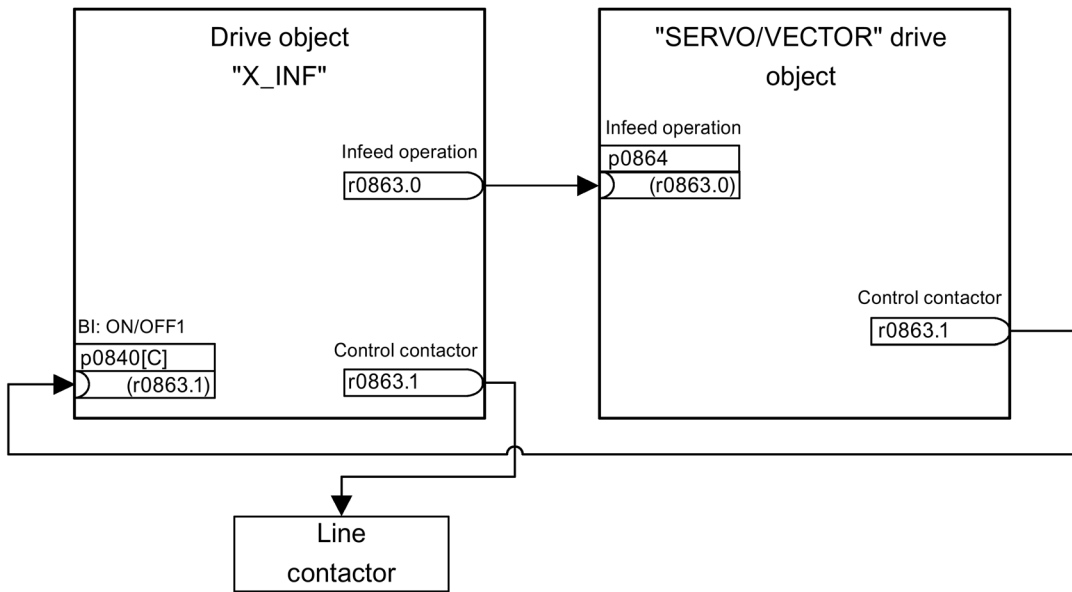

Figure 12-1 BICO interconnection: Switching on an infeed by a drive

If an application requires an automatic restart function (AR), (see Chapter Automatic restart (Page 310)), then the following extended interconnection applies:

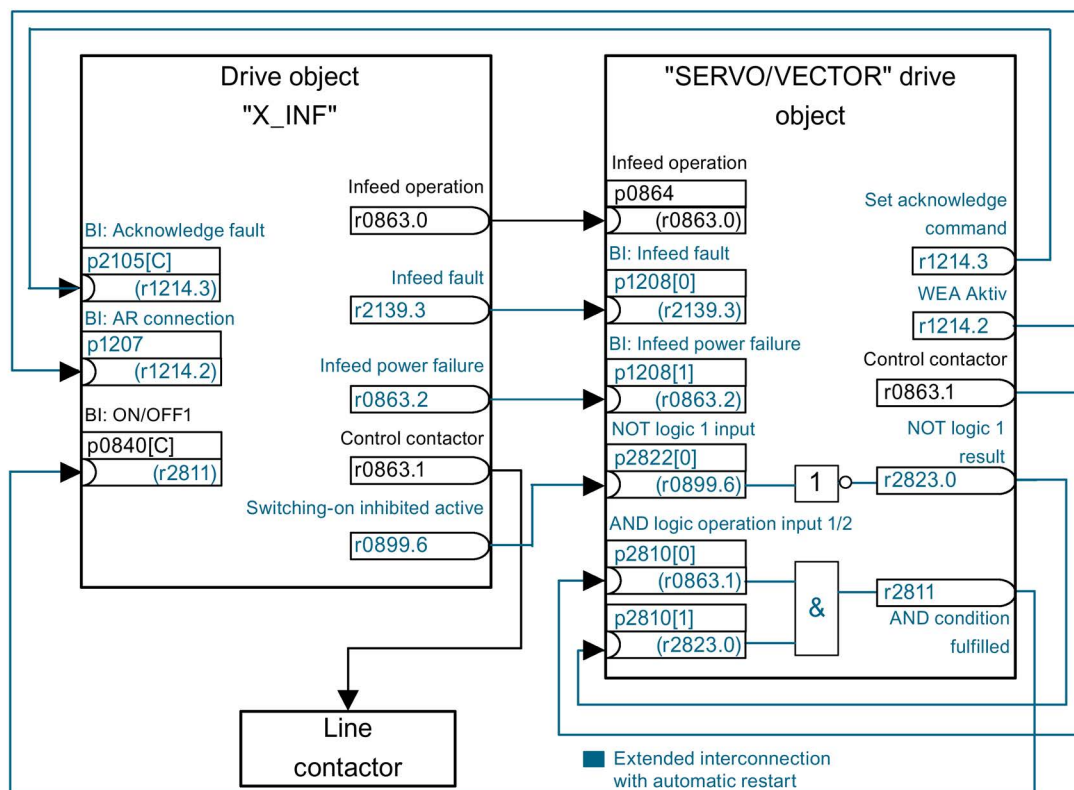

Figure 12-2 BICO interconnection: Switching on an infeed by a drive - in addition with automatic restart

- The "automatic restart" function is only activated on the "SERVO/VECTOR" drive object (p1210).
- In addition to the "AR" function, the following conditions must be fulfilled:
 - The "flying restart" function (p1200) must be activated on the "VECTOR" drive object so that a flying restart can be made.
 - The supply voltage must be reliably available at the Infeed Module (before the switch-on command, an additional line contactor or motor relay must have closed).

Individual steps when restarting:

- After the line supply returns and the electronics has booted, the faults that have occurred at the "SERVO/VECTOR" drive object as a result of its automatic restart are acknowledged depending on the settings in p1210.
- The faults of the X_INF drive object are acknowledged via the BICO connection from r1214.3 to p2105.
- The ON command (p0840) for the Infeed Module is generated via the binector output "control contactor" of the "SERVO/VECTOR" drive object (p0863.1).
It is AND'ed with the negated binector output "Switching-on inhibited" of drive object "X_INF" (r0899.6) so that when the Control Unit restarts (powers up after the 24 V returns), the necessary signal edge is generated.
- The switch-on attempt is interrupted if, during the restart, a fault occurs in the Infeed Module (drive object X_INF).
- A fault in drive object "X_INF" is communicated to the "SERVO/VECTOR" drive object via the BICO connection from p1208.0 to r2139.3 shown above.
- The automatic restart of the X_INF drive object has absolutely no significance for the described switch-on version. It is deactivated for drive object "X_INF".

**WARNING****Danger to life due to unexpected movement when the automatic restart function is activated**

When the automatic restart is activated, when the line supply returns, unexpected motion can occur that may result in death or serious injury.

- Take the appropriate measures on the plant/system side so that there is no safety risk as a result of an unexpected restart.

Overview of important parameters (see SINAMICS S120/S150 List Manual)

- r0863.0...2 CO/BO: Drive coupling status word / control word
- p0864 BI: Infeed operation
- p0840[0...n] BI: ON/OFF (OFF1)
- r0899.0...15 CO/BO: Status word sequence control
- p1200[0...n] Flying restart operating mode
- p1207 BI: Automatic restart (AR) - connection to the following drive object
- p1208[0...1] BI: Automatic restart modification, infeed
- p1210 Automatic restart mode
- r1214.0...15 CO/BO: Automatic restart status
- p2105[0...n] BI: 3. Acknowledge faults
- r2139.0...15 CO/BO: Status word, faults/alarms 1
- p2810[0...1] BI: AND logic operation inputs
- r2811.0 CO/BO: AND logic operation result
- p2822[0...3] BI: NOT logic operation input
- r2823.0...3 CO/BO: NOT logic operation result

12.3 Control Units without infeed control

To ensure that the drive line-up functions satisfactorily, you must ensure, among other things, that the drives only draw power from the DC link when the infeed is in operation. In a DC link line-up that is controlled by precisely one Control Unit and which includes a drive object X_INF¹⁾, the BICO interconnection p0864 = p0863.0 is established automatically during commissioning.

1) X_INF stands for all drive objects "Infeed"; i.e.: A_INF, B_INF, S_INF

In the following cases, the BICO input p0864 must be supplied manually:

- Smart Line Modules without DRIVE-CLiQ (5 kW and 10 kW)
- DC link line-up with more than one Control Unit

Examples: interconnecting "Infeed ready"

Smart Line Modules without DRIVE-CLiQ (5 kW and 10 kW)

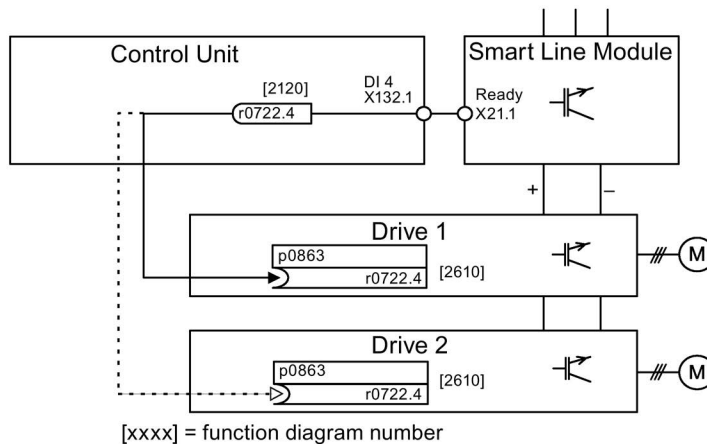

Figure 12-3 Example: interconnecting a Smart Line Module without DRIVE-CLiQ

DC link line-up with several Control Units

In the following example, two Control Units control the drives connected to the same DC link. The source for the "Infeed operation" signal is a digital input in the example.

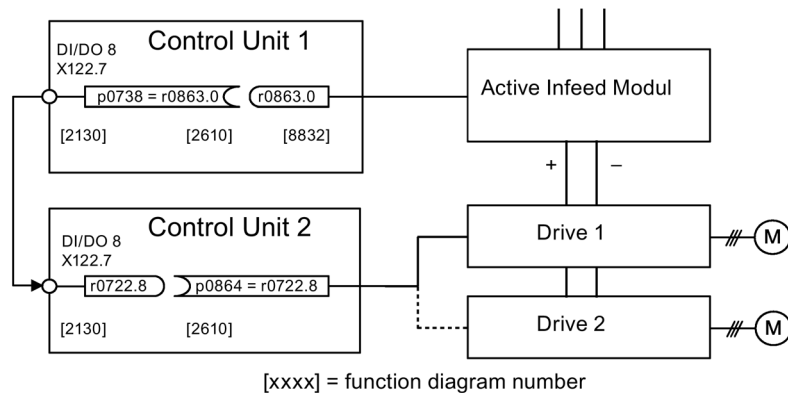

Figure 12-4 Example: interconnection with more than one Control Unit

Overview of important parameters (see SINAMICS S120/S150 List Manual)

- r0722.0...21 CO/BO: CU digital inputs, status
- r0863.0...2 CO/BO: Drive coupling status word / control word
- p0864 BI: Infeed operation

12.4 Quick stop in the event of a power failure or emergency stop (servo)

A drive line-up generally responds when the power fails with an OFF2, even when a Control Supply Module and a Braking Module is being used. This means that the connected motors coast down. The Control Supply Module provides the electronics with power via the supply system or DC link. In this way, controlled movements can be made if a power failure occurs provided that the DC link voltage is still available. The following section describes how all the drives carry out a quick stop (OFF3) if the power fails.

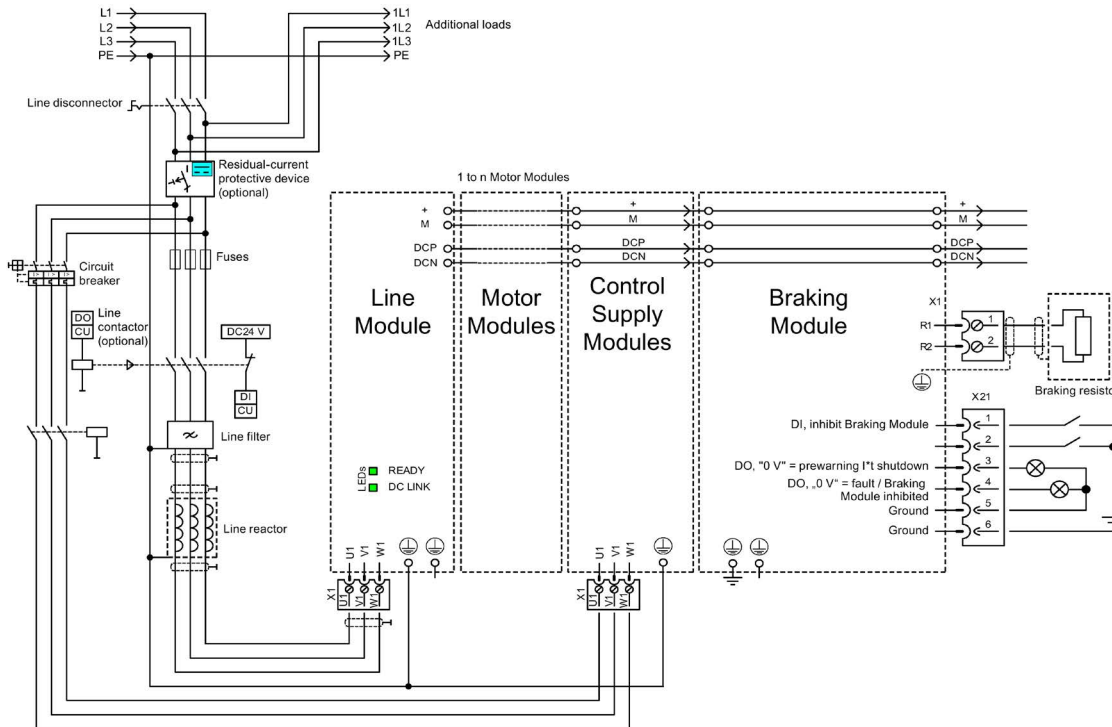

Figure 12-5 Example: interconnection of quick stop due to power failure or emergency off

In addition to the component wiring shown above, each drive object that is to carry out a quick stop if the power fails needs to be parameterized. If parameterization is not carried out, the drive coasts down once a DC link undervoltage has been identified (OFF2). To implement the OFF3 function (quick stop), the following parameters need to be set:

- p1240 = 5 (activates Vdc_min monitoring)
As well as the DC link monitor, which is always active, this activates another variable alarm threshold, which should be set to a value above the undervoltage shutdown threshold of 360 V ± 2 % in p1248.
- p1248 ≤ 570 V (for Active Line Modules)
p1248 ≤ 510 V (for Smart Line Modules)
This alarm level (in volts) indicates that the set value has been fallen below. Fault F07403 is triggered when this threshold is reached.
- p2100[x] = 7403
Here you change the response to fault F07403.
- p2101[x] = 3 (OFF3) response to the fault entered in p2100[x]

12.5 Motor changeover

Description

The motor changeover is used in the following cases, for example:

- Changing over between different motors and encoders
- Changing over different windings in a motor (e.g. star-delta changeover)
- Adapting the motor data

If several motors are operated alternately on a Motor Module, a matching number of drive data sets must be created.

Note

Vector control

For vector control, to switch to a rotating motor the "flying restart (Page 247)" function must be activated (p1200).

Note

When changing over the drive data set between several motors that physically exist with integrated holding brakes, it is not permissible that the internal brake control is used.

Example of a motor changeover for four motors (encoderless)

Requirements

- The first commissioning has been completed.
- 4 motor data sets (MDS), p0130 = 4
- 4 drive data sets (DDS), p0180 = 4
- 4 digital outputs to control the auxiliary contactors
- 4 digital inputs to monitor the auxiliary contactors
- 2 digital inputs for selecting the data set
- 4 auxiliary contactors with auxiliary contacts (1 NO contact)

- 4 motor contactors with positively driven auxiliary contacts (3 NC contacts, 1 NO contact)
- 4 motors, 1 Control Unit, 1 infeed, and 1 Motor Module

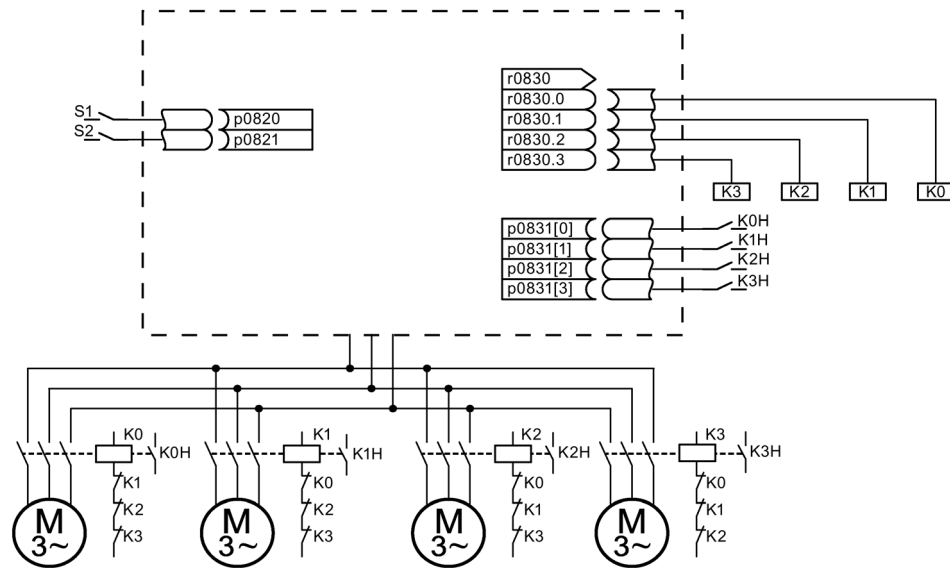

Figure 12-6 Example of motor changeover

Table 12- 1 Settings for the example

Parameter	Settings	Remark
p0130	4	Configure four MDS.
p0180	4	Configure four DDS.
p0186[0...3]	0, 1, 2, 3	The MDS are assigned to the DDS.
p0820, p0821	Digital inputs DDS selection	The digital inputs for motor changeover via DDS selection are selected. Binary coding is used (p0820 = bit 0, etc.).
p0822 to p0824	0	
p0826[0...3]	0, 1, 2, 3	Different numbers indicate a different thermal model.
p0827[0...3]	0, 1, 2, 3	Assigning the bit from r0830 to the MDS. If p0827[0] = 1, for example, bit p0830.1 is set when MDS0 is selected via DDS0.
r0830.0 to r0830.3	Digital outputs, contactors	The digital outputs for the contactors are assigned to the bits.
p0831[0...3]	Digital inputs, auxiliary contacts	The digital inputs for the feedback signal of the motor contactors are assigned.
p0833.0..2	0, 0, 0	The drive controls the contactor circuit and pulse inhibition. Parking bit (Gn_ZSW14) is set.

Procedure for changeover between motor data sets

1. Start condition:

For synchronous motors, the actual speed must be lower than the speed at the start of field weakening. This prevents the regenerative voltage from exceeding the terminal voltage.

2. Pulse inhibit:

The pulses are inhibited after a new drive data set is selected with p0820 to p0824.

3. Open the motor contactor:

Motor contactor 1 is opened (r0830 = 0) and the status bit "Motor changeover active" (r0835.0) is set.

4. Change over the drive data set:

The requested data set is activated (r0051 = requested data set).

5. Energize the motor contactor:

After the feedback signal (motor contactor opened) for motor contactor 1, the appropriate bit of r0830 is set and motor contactor 2 is energized.

6. Enable the pulses:

After the feedback signal (motor contactor closed) for motor contactor 2, the bit "motor changeover active" (r0835.0) is reset and the pulses are enabled. The motor has now been changed over.

Example of a star-delta changeover (via speed threshold; encoderless)

Requirements

- The first commissioning has been completed.
- 2 motor data sets (MDS), p0130 = 2
- 2 drive data sets (DDS), p0180 = 2
- 2 digital outputs to control the auxiliary contactors
- 2 digital inputs to monitor the auxiliary contactors
- 1 free speed monitoring (p2155)
- 2 auxiliary contactors with auxiliary contacts (1 NO contact)
- 2 motor contactors with positively driven auxiliary contacts (1 NC contact, 1 NO contact)
- 1 motor, 1 Control Unit, 1 infeed, and 1 Motor Module

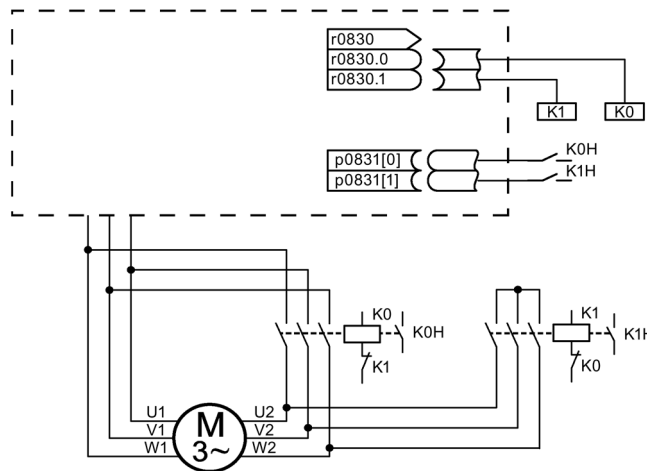

Figure 12-7 Example: star-delta changeover

Table 12-2 Settings for the example

Parameter	Settings	Remark
p0130	2	Configure two MDS.
p0180	2	Configure two DDS.
p0186[0...1]	0, 1	The MDS are assigned to the DDS.
p0820	p2197.2	Changeover to delta connection after speed in p2155 is exceeded.
p0821 to p0824 0	0	
p0826[0...1]	0; 0	Identical numbers signify the same thermal model.
p0827[0...1]	0, 1	Assigning the bit from r0830 to the MDS. If p0827[0] = 1, for example, bit r0830.1 is set when MDS0 is selected via DDS.
r0830.0 and r0830.1	Digital outputs, contactors	The digital outputs for the contactors are assigned to the bits.
p0831[0...1]	Digital inputs, auxiliary contacts	The digital inputs for the feedback signal of the motor contactors are assigned.

Parameter	Settings	Remark
p0833.0..2	0, 0, 0	The drive controls the contactor circuit and pulse inhibition. Parking bit (Gn_ZSW14) is set.
p2155.0...1	Changeover speed	Sets the speed at which the circuit is to be changed over to the delta connection. Note: Using p2140, you can define an additional hysteresis for the changeover (refer to function diagram 8010 in the SINAMICS S120/150 List Manual).

Procedure for star-delta changeover

1. Start condition:

For synchronous motors, the actual speed must be lower than the star field-weakening speed. This prevents the regenerative voltage from exceeding the terminal voltage.

2. Pulse inhibit:

The pulses are suppressed after the changeover speed (p2155) is reached.

3. Open the motor contactor:

Motor contactor 1 is opened (r0830 = 0) and the status bit "Motor data set changeover active" (r0835.0) is set.

4. Change over the drive data set:

The requested data set is activated (r0051 = requested data set).

5. Energize the motor contactor:

After the feedback signal (motor contactor opened) for motor contactor 1, the appropriate bit of r0830 is set and motor contactor 2 is energized.

6. Enable the pulses:

After the feedback signal (motor contactor closed) for motor contactor 2, the bit "motor changeover active" (r0835.0) is reset and the pulses are enabled. The changeover is complete.

Function diagrams (see SINAMICS S120/S150 List Manual)

- 8565 Data sets - Drive Data Sets (DDS)
- 8570 Data sets - Encoder Data Sets (EDS)
- 8575 Data sets - Motor Data Sets (MDS)

Overview of important parameters (see SINAMICS S120/S150 List Manual)

- r0051[0...4] CO/BO: Drive data set DDS effective
- p0130 Motor data sets (MDS) number
- p0140 Encoder data sets (EDS) number
- p0180 Drive data set (DDS) number
- p0186 [0...n] Motor data sets (MDS), number
- p0187[0...n] Encoder 1 encoder data set number
- p0188[0...n] Encoder 2 encoder data set number
- p0189[0...n] Encoder 3 encoder data set number
- p0820[0...n] BI: Drive data set selection DDS, bit 0
- ...
- p0824[0...n] BI: Drive data set selection DDS, bit 4
- p0826 [0...n] Motor changeover, motor number
- p0827 [0...n] Motor changeover status word bit number
- p0828 [0...n] BI: Motor changeover feedback
- r0830.0...15 CO/BO: Motor changeover status word
- p0831[0...15] BI: Motor changeover contactor feedback
- p0833 Data set changeover configuration

12.6 Application examples with DMC20

The DRIVE-CLiQ Hub Module Cabinet 20 (DMC20/DME20) is used for the star-shaped distribution of a DRIVE-CLiQ line. With the DMC20, an axis grouping can be expanded with five DRIVE-CLiQ sockets for additional subgroups.

The component is especially suitable for applications which require DRIVE-CLiQ nodes to be removed in groups, without interrupting the DRIVE-CLiQ line and, therefore, the data exchange process.

DME20

DME20 offers the same functions as the DMC20. However, the difference is that it has a different enclosure with degree of protection IP67 for mounting outside a control cabinet.

Features

The DRIVE-CLiQ Hub Module Cabinet 20 (DMC20) has the following features:

- Own drive object
- Six DRIVE-CLiQ ports
- Own faults and alarms

Typical applications:

- Implementation of a distributed topology via a DRIVE-CLiQ cable
- Hot-plugging (a DRIVE-CLiQ connection is withdrawn in operation)

Example: Distributed structure

Several direct length measuring systems are used in a machine. These are to be combined in a control cabinet and connected to the Control Unit via a DRIVE-CLiQ cable.

When a DMC20 is used, up to five measuring systems can be combined.

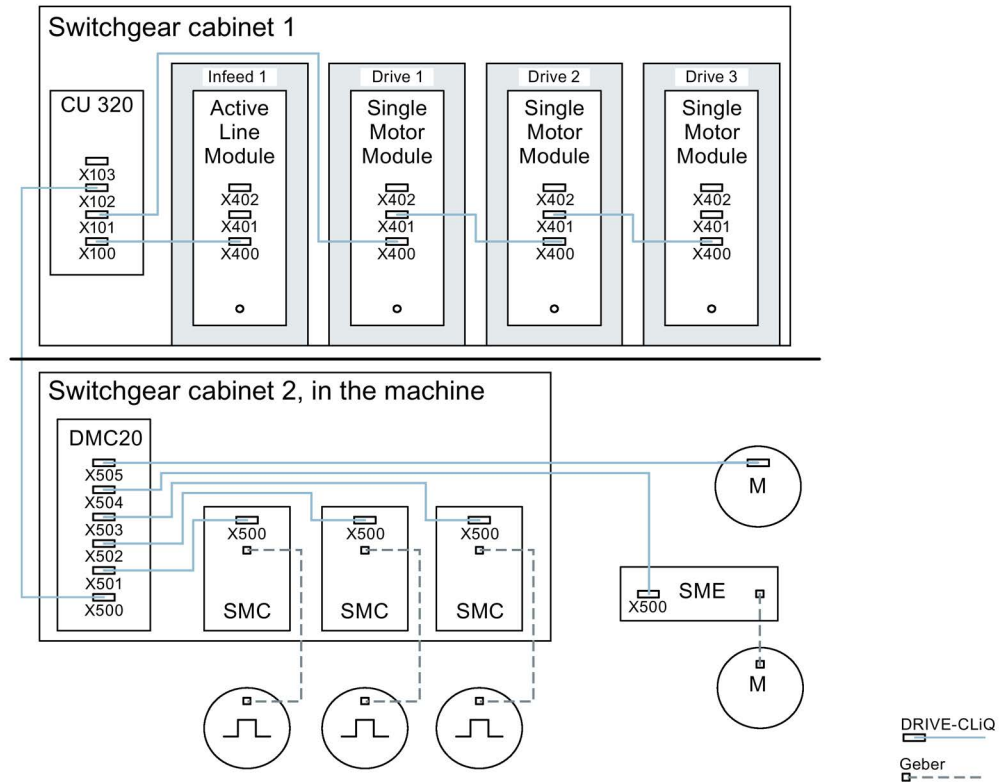

Figure 12-8 Example, distributed topology using DMC20

Example: Hot-plugging

Using the hot-plugging function, components can be withdrawn from the operational drive line-up (the other components continue to operate) on the DRIVE-CLiQ line. This means that all of the drive objects or components involved must first be deactivated/parked using parameter p0105 or STW2.7.

The following requirements must be satisfied:

Hot-plugging only functions when a drive object is connected in a star configuration to a Control Unit or to the DRIVE-CLiQ Hub DMC20/DME20.

The system does not support removing DRIVE-CLiQ connections between the other DRIVE-CLiQ components, e.g. Sensor/Terminal Module to Motor Module, Motor Module to Motor Module.

The complete drive object (Motor Module, motor encoder, Sensor Module) is disabled via p0105.

STW2.7 is used to set the function "Park axis" for all components that are assigned to the motor control (Motor Module, motor encoders). All components that belong to Encoder_2 or Encoder_3 remain active. The "Park axis" function is only enabled by setting the ZSW2.7 bit in combination with pulse inhibit.

Note

Drives with enabled Safety functions must not be deactivated, see Section "Safety Integrated" for further details.

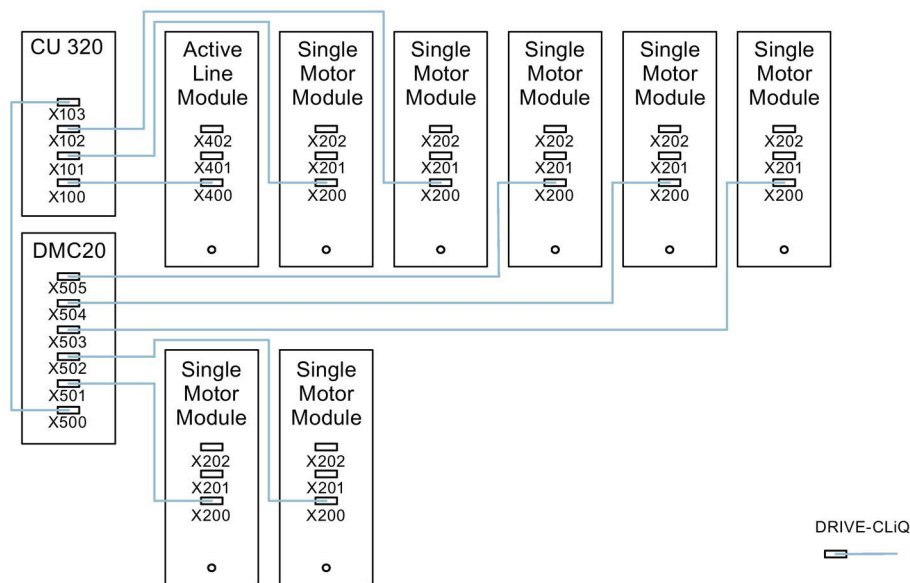

Figure 12-9 Example topology for hot-plugging for vector V/f control

Note

In order to disconnect and isolate the power unit from the DC link, additional measures must be applied - such as DC link wiring through the DC link infeed adapter and DC link disconnecting devices. The safety information and instructions in the Equipment Manual must be carefully observed.

Instructions for offline commissioning with STARTER

With automatic online configuration in STARTER, the DMC20 is detected and integrated in the topology. The following steps must be taken to commission offline:

1. Configure the offline drive device.
2. Right-click "Topology" in the project navigator and call the "Add new object > DRIVE-CLiQ hub" context menu.
3. Configure the topology.

Overview of important parameters (see SINAMICS S120/S150 List Manual)

- p0105 Activate/deactivate drive object
- r0106 Drive object active/inactive
- p0151[0...1] DRIVE-CLiQ Hub Module component number
- p0154 DRIVE-CLiQ Hub Module detection via LED
- p0157 DRIVE-CLiQ Hub Module EEPROM data version
- r0158 DRIVE-CLiQ Hub Module firmware version
- r0896.0 BO: Parking axis status word
- p0897 BI: Parking axis selection

12.7 DCC and DCB extension applications

You can find further application examples, such as applications with DCC, on the Siemens homepage.

Finding and calling application examples

1. Call the following Internet site in your browser:

SINAMICS application examples (<https://www.automation.siemens.com/mc-app/sinamics-application-examples/Home/Index?language=en>)

2. If you are looking for applications with DCC, select the "DCC" feature in the search mask.

All the DCC applications for which you can download application examples are then shown in the results. Example:

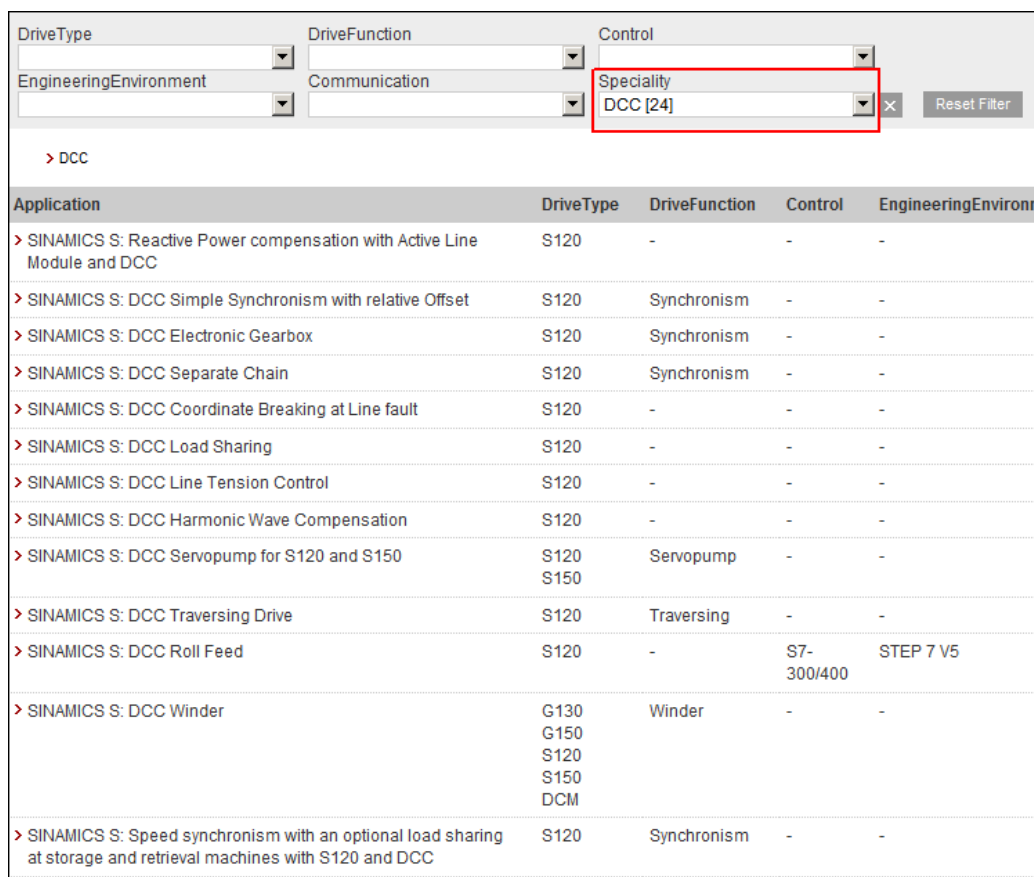

Application	DriveType	DriveFunction	Control	EngineeringEnvironment
> SINAMICS S: Reactive Power compensation with Active Line Module and DCC	S120	-	-	-
> SINAMICS S: DCC Simple Synchronism with relative Offset	S120	Synchronism	-	-
> SINAMICS S: DCC Electronic Gearbox	S120	Synchronism	-	-
> SINAMICS S: DCC Separate Chain	S120	Synchronism	-	-
> SINAMICS S: DCC Coordinate Breaking at Line fault	S120	-	-	-
> SINAMICS S: DCC Load Sharing	S120	-	-	-
> SINAMICS S: DCC Line Tension Control	S120	-	-	-
> SINAMICS S: DCC Harmonic Wave Compensation	S120	-	-	-
> SINAMICS S: DCC Servopump for S120 and S150	S120 S150	Servopump	-	-
> SINAMICS S: DCC Traversing Drive	S120	Traversing	-	-
> SINAMICS S: DCC Roll Feed	S120	-	S7-300/400	STEP 7 V5
> SINAMICS S: DCC Winder	G130 G150 S120 S150 DCM	Winder	-	-
> SINAMICS S: Speed synchronism with an optional load sharing at storage and retrieval machines with S120 and DCC	S120	Synchronism	-	-

Figure 12-10 Overview of the DCC applications with application descriptions

3. Click the required DCC application.

A tooltip on the required DCC application is then displayed in the Siemens Industry Online Support. Generally, you can download a detailed application description as PDF via the tooltip.

Example: Synchronous operation applications with DCC

You require the "Synchronous operation" drive function and the "DCC" feature as filter settings.

Application	DriveType	DriveFunction	Control	EngineeringEnvironment	Communication	Speciality
> SINAMICS S: DCC Simple Synchronism with relative Offset	S120	Synchronism	-	-	-	DCC
> SINAMICS S: DCC Electronic Gearbox	S120	Synchronism	-	-	-	DCC
> SINAMICS S: DCC Separate Chain	S120	Synchronism	-	-	-	DCC
> SINAMICS S: Speed synchronism with an optional load sharing at storage and retrieval machines with S120 and DCC	S120	Synchronism	-	-	-	DCC
> SINAMICS S: S120 Gearing and positioning with DCC	S120	Synchronism	-	-	-	DCC
> SINAMICS S: S120 Camming with DCC	S120	Synchronism	-	-	-	DCC
> SINAMICS S: S120 1:1 Synchronism with DCC	S120	Synchronism	-	-	-	DCC
> SINAMICS S: S120 Gearing with DCC	S120	Synchronism	-	-	-	DCC

Figure 12-11 The most important synchronous operation application examples are marked in red in the figure.

Basic information about the drive system

13.1 Parameter

The following adjustable and display parameters are available:

- Adjustable parameters (write/read)

These parameters have a direct impact on the behavior of a function.

Example: Ramp-up and ramp-down time of a ramp-function generator

- Display parameters (read-only)

These parameters are used to display internal variables.

Example: Current motor current

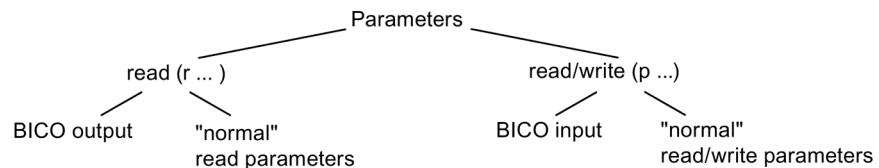

Figure 13-1 Parameter types

All these drive parameters can be read via PROFIBUS and changed by means of p parameters using the mechanisms defined in the PROFIdrive profile.

Parameter categories

The parameters of the individual drive objects are categorized into data sets as follows:

- Data-set-independent parameters

These parameters exist only once per drive object.

- Data-set-dependent parameters

These parameters can exist several times for each drive object and can be addressed via the parameter index for reading and writing. A distinction is made between various types of data set:

- CDS: Command Data Set

By parameterizing several command data sets and switching between them, the drive can be operated with different pre-configured signal sources.

- DDS: Drive Data Set

The drive data set contains the parameters for switching between different drive control configurations.

13.1 Parameter

The CDS and DDS can be switched over during normal operation. Further types of data set also exist, however these can only be activated indirectly by means of a DDS changeover.

- EDS Encoder Data Set
- MDS Motor Data Set

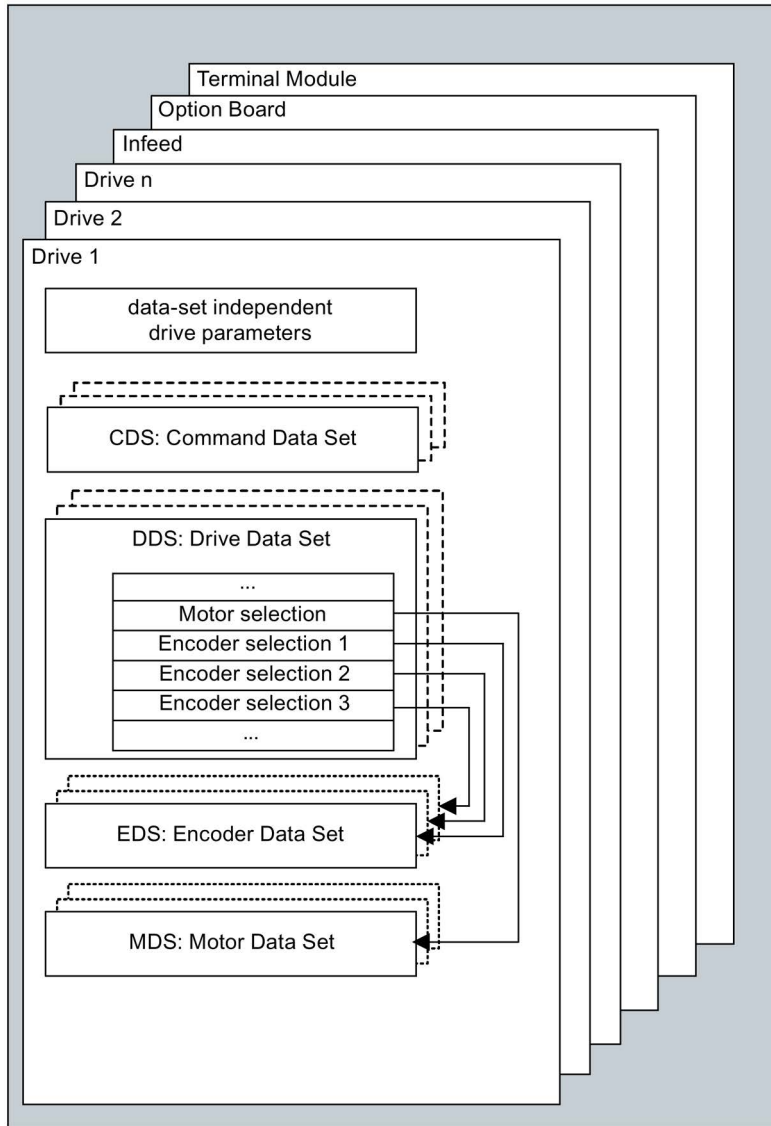

Figure 13-2 Parameter categories

Saving parameters in a non-volatile memory

The modified parameter values are stored in the volatile RAM. When the drive system is switched off, this data is lost.

The data must be saved retentively on the memory card, as described below, so that it is available the next time the drive is switched on.

- Save parameters - device and all drives
p0977 = 1; automatically reset to 0
- Save the parameters with STARTER
See "Copy RAM to ROM" function

Resetting parameters

The parameters can be reset to the factory setting as follows:

- Reset parameters - current drive object
p0970 = 1; automatically reset to 0
- Reset parameters - all parameters of the drive object "Control Unit" (CU_*)
p0009 = 30 parameter reset
p0976 = 1; automatically reset to 0

Access level

The parameters are subdivided into access levels. The SINAMICS S120/S150 List Manual specifies the access level in which the parameter is displayed and can be changed. The required access levels 0 to 4 can be set in p0003.

Table 13- 1 Access levels

Access level		Remark
0	User defined	Parameters from the user-defined list (p0013)
1	Standard	Parameters for the simplest operator functions (e.g. p1120 = ramp-function generator ramp-up time)
2	Advanced	Parameters to handle the basic functions of the device.
3	Expert	Expert knowledge is already required for this parameter (e.g. knowledge about BICO parameterization)
4	Service	Please contact your local Siemens office for the password for parameters with access level 4 (Service). It must be entered into p3950.

Note

Parameter p0003 is CU-specific (available on the Control Unit).

13.2 Data sets

13.2.1 CDS: Command data set

The BICO parameters are combined (binector and connector inputs) in a command data set (CDS). These parameters are used to interconnect the signal sources of a drive.

By parameterizing several command data sets and switching between them, the drive can be operated with different pre-configured signal sources.

A command data set contains the following (examples):

- Binector inputs for control commands (digital signals)
 - ON/OFF, enable signals (p0844, etc.)
 - Jog (p1055, etc.)
- Connector inputs for setpoints (analog signals)
 - Voltage setpoint for V/f control (p1330)
 - Torque limits and scaling factors (p1522, p1523, p1528, p1529)

A drive object can – depending on the type – manage up to 4 command data sets. The number of command data sets is configured with p0170.

The following parameters are available for selecting command data sets and for displaying currently selected command data sets - e.g. in the vector mode:

Binector inputs p0810 to p0811 are used to select a command data set. They represent the number of the command data set (0 to 3) in binary format (where p0811 is the most significant bit).

- p0810 BI: Command data set selection CDS bit 0
- p0811 BI: Command data set selection CDS bit 1

If a command data set that does not exist is selected, the current data set remains active. The selected data set is displayed using parameter (r0836).

Note

When using standard telegrams in command data records, make sure that you do not change telegram interconnections as this may lead to inconsistent behavior otherwise. If you wish to change telegram interconnections, please assign the telegram selection with 999 (free telegram).

Example: Changeover between command data set 0 and 1

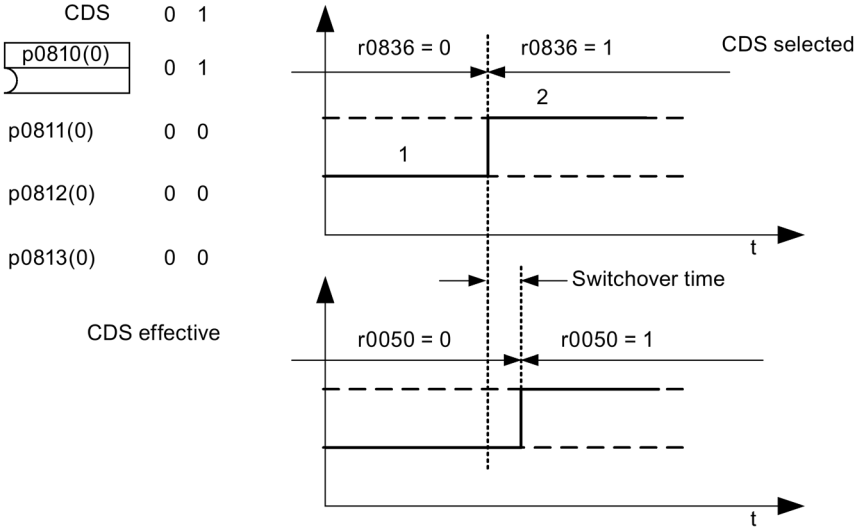

Figure 13-3 Switching the command data set (example)

13.2.2 DDS: Drive Data Set

A drive data set (DDS) contains various adjustable parameters that are relevant for open-loop and closed-loop drive control:

- Numbers of the assigned motor and encoder data sets:
 - p0186: Assigned motor data set (MDS)
 - p0187 to p0189: Up to three assigned encoder data sets (EDS)
- Various control parameters, e.g.:
 - Fixed speed setpoints (p1001 to p1015)
 - Speed limits min./max. (p1080, p1082)
 - Characteristic data of ramp-function generator (p1120 ff)
 - Characteristic data of controller (p1240 ff)
 - ...

The parameters that are grouped together in the drive data set are identified in the SINAMICS S120/S150 List Manual by "Data Set DDS" and are assigned an index [0...n].

It is possible to parameterize several drive data sets. You can switch easily between different drive configurations (control type, motor, encoder) by selecting the corresponding drive data set.

One drive object can manage up to 32 drive data sets. The number of drive data sets is configured with p0180.

Binector inputs p0820 to p0824 are used to select a drive data set. They represent the number of the drive data set (0 to 31) in binary format (where p0824 is the most significant bit).

- p0820 BI: Drive data set selection DDS, bit 0
- p0821 BI: Drive data set selection DDS, bit 1
- p0822 BI: Drive data set selection DDS, bit 2
- p0823 BI: Drive data set selection DDS, bit 3
- p0824 BI: Drive data set selection DDS, bit 4

Supplementary conditions and recommendations

- Recommendation for the number of drive data sets for a drive

The number of drive data sets for a drive should correspond to the options for changeover. The following must therefore apply:

$p0180 \text{ (DDS)} \geq \max. (p0120 \text{ (PDS)}, p0130 \text{ (MDS)})$

- Max. number of DDS for one drive object = 32 DDS

13.2.3 EDS: Encoder Data Set

An encoder data set (EDS) contains various adjustable parameters of the connected encoder, which are relevant for configuring the drive; e.g.:

- Encoder interface component number (p0141)
- Encoder component number (p0142)
- Encoder type selection (p0400)

The parameters that are grouped together in the encoder data set are identified in the parameter list by "Data Set EDS" and are assigned an index [0...n].

A separate encoder data set is required for each encoder controlled by the Control Unit. Up to three encoder data sets are assigned to a drive data set via parameters p0187, p0188, and p0189.

An encoder data set can only be changed over using a DDS switchover.

An encoder data set switchover without pulse inhibit (motor is being fed with power) may only be performed on adjusted encoders (pole position identification has been carried out or the commutation angle determined for absolute encoders).

Each encoder must only be assigned to one drive.

Using a power unit for the alternating operation of several motors would be an EDS switchover application. Contactors are switched over so that the power unit can be connected to the different motors. Each of the motors can be equipped with an encoder or can also be operated without an encoder. Each encoder must be connected to its own SMx.

If encoder 1 (p0187) is switched over via DDS, then an MDS must also be switched over.

Note

Switching over between several encoders

In order to be able to switch between two or more encoders using the EDS switched function, you must connect these encoders via various Sensor Modules or DRIVE-CLiQ ports.

When using the same connection for several encoders, the same EDS and the same encoder type must be used. In this case a switched on the analog side (e.g. of the SMC) is recommended. A switched on the DRIVE-CLiQ side is, due to the permissible insertion cycles and the longer times to establish DRIVE-CLiQ communication, only possible with some restrictions.

If a motor is operated with motor encoder 1 and then later with motor encoder 2, two different MDSs must be created with identical motor data.

One drive object can manage up to 16 encoder data sets. The number of encoder data sets configured is specified in p0140.

When a drive data set is selected, the assigned encoder data sets are also selected.

Note

EDS switchover for safe motion monitoring

An encoder which is used for safety functions must not be switched over when a drive data set (DDS) is switched over.

The safety functions check the safety-relevant encoder data for changes when data sets are switched over. If a change is detected, fault F01670 is displayed with a fault value of 10, which results in a non-acknowledgeable STOP A. The safety-relevant encoder data in the various data sets must therefore be identical.

13.2.4 MDS: Motor Data Set

A motor data set (MDS) contains various setting parameters of the connected motor, which are relevant when configuring the drive. It also contains certain display parameters with calculated data.

- Adjustable parameters, e.g.:
 - Motor component number (p0131)
 - Motor type selection (p0300)
 - Rated motor data (p0304 ff.)
 - ...
- Display parameters, e.g.:
 - Calculated rated data (p0330 ff.)
 - ...

The parameters that are grouped together in the motor data set are identified in the SINAMICS S120/S150 List Manual by "Data Set MDS" and are assigned an index [0...n].

A separate motor data set is required for each motor that is controlled by the Control Unit via a Motor Module. The motor data set is assigned to a drive data set via parameter p0186.

A motor data set can only be changed using a DDS changeover. The motor data set changeover is, for example, used for:

- Changing over between different motors
- Changing over different windings in a motor (e.g. star-delta changeover)
- Adapting the motor data

If several motors are operated alternately on a Motor Module, a matching number of drive data sets must be created. Further information about motor changeover, see Section Motor changeover in this manual.

One drive object can manage up to 16 motor data sets. The number of motor data sets in p0130 must not exceed the number of drive data sets in p0180.

For the 611U interface mode (p2038 = 1), the drive data sets are divided into groups of eight (1-8; 9-16;...). Within a group, the assignment to the motor data set must be identical:

p0186[0] = p0186[1] = ... = p0186[7]
 p0186[8] = p0186[9] = ... = p0186[15]
 p0186[16] = p0186[17] = ... = p0186[23]
 p0186[24] = p0186[25] = ... = p0186[31]

If this rule is not observed, alarm A07514 is output. If you need a precise representation of the data set structure of the 611U, 32 drive data sets and 4 motor data sets must be configured.

Example of data set assignment

Table 13- 2 Example, data set assignment

DDS	Motor (p0186)	Encoder 1 (p0187)	Encoder 2 (p0188)	Encoder 3 (p0189)
DDS 0	MDS 0	EDS 0	EDS 1	EDS 2
DDS 1	MDS 0	EDS 0	EDS 3	-
DDS 2	MDS 0	EDS 0	EDS 4	EDS 5
DDS 3	MDS 1	EDS 6	-	-

13.2.5 Function diagrams and parameters

Function diagrams (see SINAMICS S120/S150 List Manual)

- 8560 Data sets - Command Data Sets (CDS)
- 8565 Data sets - Drive Data Sets (DDS)
- 8570 Data sets - Encoder Data Sets (EDS)
- 8575 Data sets - Motor Data Sets (MDS)

Overview of important parameters (see SINAMICS S120/S150 List Manual)

- p0120 Power Module data sets (PDS) number
- p0130 Motor data sets (MDS) number
- p0139[0...2] Copy motor data set (MDS)
- p0140 Encoder data sets (EDS) number
- p0170 Command data set (CDS) number
- p0180 Drive data set (DDS) number
- p0186 [0...n] Motor data sets (MDS) number
- p0187[0...n] Encoder 1 encoder data set number
- p0188[0...n] Encoder 2 encoder data set number
- p0189[0...n] Encoder 3 encoder data set number
- p0809[0...2] Copy Command Data Set CDS
- p0810 BI: Command data set selection CDS bit 0
- p0811 BI: Command data set selection CDS bit 1
- p0819[0...2] Copy drive data set DDS
- p0820[0...n] BI: Drive data set selection DDS, bit 0
- p0821[0...n] BI: Drive data set selection DDS, bit 1
- p0822[0...n] BI: Drive data set selection DDS, bit 2
- p0823[0...n] BI: Drive data set selection DDS, bit 3
- p0824[0...n] BI: Drive data set selection DDS, bit 4

13.3 Drive objects

A drive object (DO) is an independent, "self-contained" software function that has its own parameters and, in some cases, its own faults and alarms. Drive objects can be provided as standard (e.g. I/O evaluation), or you can add single (e.g. terminal board) or multiple objects (e.g. drive control).

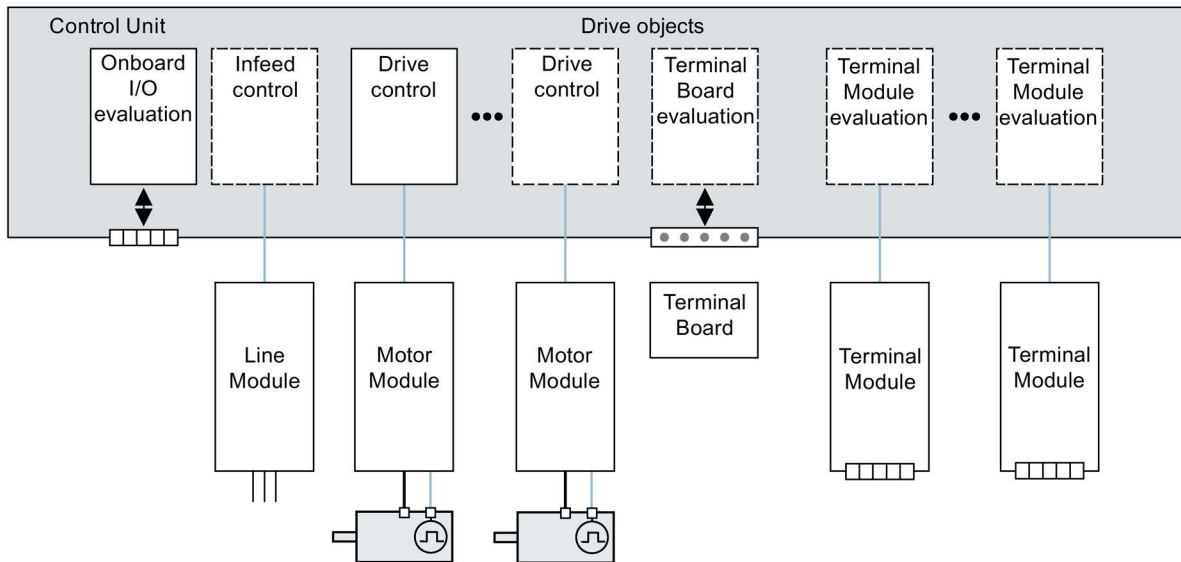

Figure 13-4 Drive objects

Overview of the drive objects

- Drive control

The drive control handles closed-loop control of the motor. At least 1 Motor Module and at least 1 motor and up to 3 sensors are assigned to the drive control.

Various drive control modes can be configured (e.g. servo control, vector control, etc.).

Several drive controls can be configured, depending on the performance of the Control Unit and the demands made on the drive control system.

- Control Unit, inputs/outputs

The I/Os on the Control Unit are evaluated within a drive object. High-speed inputs for probes are processed here in addition to bidirectional digital I/Os.

- Properties of a drive object

- Separate parameter space
- Separate window in STARTER
- Separate fault/alarm system
- Separate PROFIdrive telegram for process data

13.3 Drive objects

- Supply: Line Module infeed control with DRIVE-CLiQ interface
If an Active Line Module with a DRIVE-CLiQ interface is used for the infeed in a drive system, open-loop/closed-loop control is implemented on the Control Unit within a corresponding drive object.
- Supply: Line Module infeed control with DRIVE-CLiQ interface
If a Line Module without a DRIVE-CLiQ interface is used for the infeed in a drive system, the Control Unit must handle activation and evaluation of the corresponding signals (RESET, READY).
- Option Board evaluation
An additional drive object is responsible for evaluating an inserted option board. The specific method of operation depends on the type of option board.
- Terminal Module evaluation
A separate drive object handles evaluation of the respective optional Terminal Modules.
- Evaluating an external ENCODER
A dedicated drive object is responsible for evaluating an optional additional encoder that can be connected.

Note

Drive objects

A list of all drive objects is provided in the SINAMICS S120/S150 List Manual in Section Overview of parameters.

Configuring drive objects

Various drive objects can be created within a Control Unit. When commissioning for the first time, these drive objects can be set up using STARTER.

The drive objects are configurable function blocks and are used to execute specific drive functions.

If you need to configure additional drive objects or delete existing ones after first commissioning, the drive system must be switched to configuration mode.

The parameters of a drive object cannot be accessed until the drive object has been configured and you have switched from configuration mode to parameterization mode.

Note

Each installed drive object is allocated a number between 0 and 63 during first commissioning for unique identification.

Overview of important parameters (see SINAMICS S120/S150 List Manual)

- p0101[0...n] Drive object numbers
- r0102[0...1] Number of drive objects
- p0107[0...n] Drive object type
- p0108[0...n] Drive object function module (only for "Control Unit" drive object)
- r0108 Drive object function module (all other drive objects)

13.4 BICO technology: Interconnecting signals

Every drive contains a large number of interconnectable input and output variables and internal control variables.

BICO technology (Binector Connector Technology) allows the drive to be adapted to a wide variety of requirements.

Digital and analog signals which can be connected freely by means of BICO parameters, are identified by the prefix BI, BO, CI or CO in their parameter name.

These parameters are identified accordingly in the parameter list or in the function diagrams.

Note

The STARTER commissioning tool is recommended when using BICO technology.



13.4.1 Binectors, connectors

Binectors, BI: Binector Input, BO: Binector Output

A binector is a digital (binary) signal without a unit which can assume the value 0 or 1.

Binectors are subdivided into binector inputs (signal sink) and binector outputs (signal source).



Table 13-3 Binectors

Abbreviation	Symbol	Name	Description
BI		Binector input (signal sink)	Can be interconnected to a binector output as source. The number of the binector output must be entered as a parameter value.
BO		Binector output (signal source)	Can be used as a source for a binector input.

Connectors, CI: Connector Input, CO: Connector Output

A connector is a digital signal, e.g. in 32-bit format. It can be used to emulate words (16 bits), double words (32 bits) or analog signals. Connectors are subdivided into connector inputs (signal sink) and connector outputs (signal source).

Table 13- 4 Connectors

Abbrevia- tion	Symbol	Name	Description
CI		Connector input (signal sink)	Can be interconnected to a connector output as source. The number of the connector output must be entered as a parameter value.
CO		Connector output (signal source)	Can be used as a source for a connector input.

13.4.2 Interconnecting signals using BICO technology

To interconnect two signals, a BICO input parameter (signal sink) must be assigned to the desired BICO output parameter (signal source).

The following information is required in order to connect a binector/connector input to a binector/connector output:

- Binectors: Parameter number, bit number, and drive object ID
- Connectors with no index: Parameter number and drive object ID
- Connectors with index: Parameter number, index, and drive object ID
- Data type (signal source for connector output parameter)

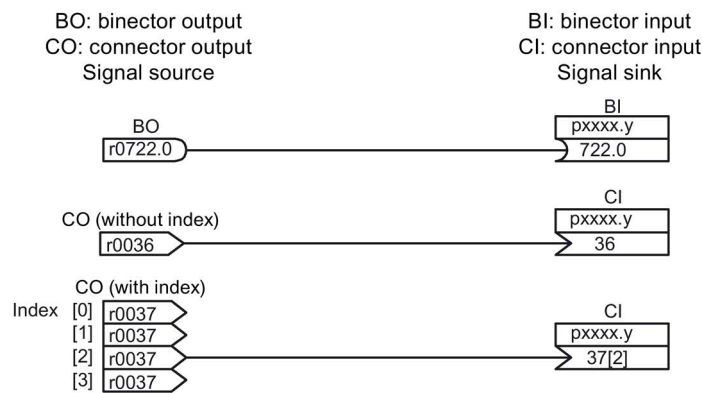

Figure 13-5 Interconnecting signals using BICO technology

Note

A connector input (CI) cannot be interconnected with any connector output (CO, signal source). The same applies to the binector input (BI) and binector output (BO). For each CI and BI parameter, the parameter list shows under "data type" the information on the data type of the parameter and the data type of the BICO parameter. For CO parameters and BO parameters, only the data type of the BICO parameter is shown.

Notation:

- Data type BICO input: Data type parameter/Data type BICO parameter
Example: Unsigned32 / Integer16
- Data type BICO output: Data type BICO parameter
Example: FloatingPoint32

The possible interconnections between the BICO input (signal sink) and BICO output (signal source) are listed in the table titled "Possible combinations for BICO interconnections", which can be found in the "Explanations on the parameter list" section of the SINAMICS S120/S150 List Manual.

The BICO parameter interconnection can be implemented in different command data sets (CDS). The different interconnections are activated by switching data sets. Interconnections across drive objects are also possible.

13.4.3 Internal coding of the binector/connector output parameters

Internal coding is required for writing BICO input parameters via PROFIBUS, for example.

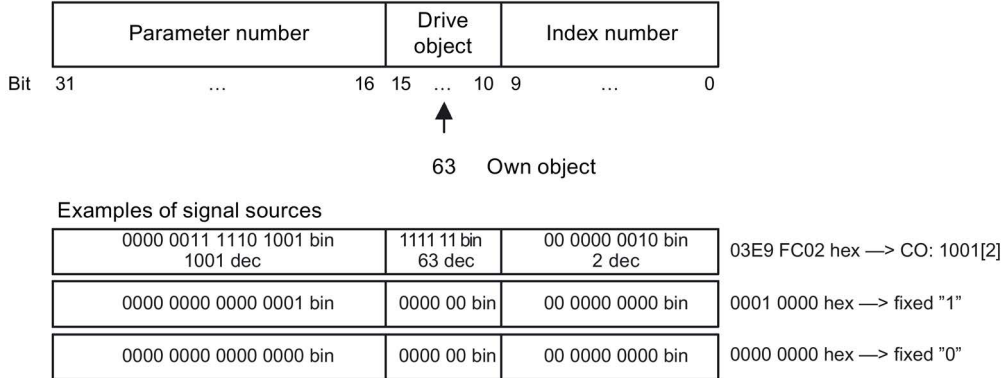

Figure 13-6 Internal coding of the binector/connector output parameters

13.4.4 Sample interconnections

Example 1: Interconnection of digital signals

Suppose you want to operate a drive via terminals DI 0 and DI 1 on the Control Unit using jog 1 and jog 2.

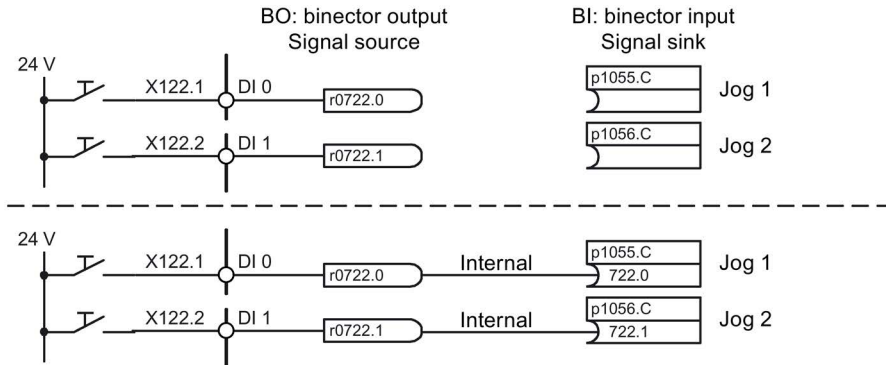

Figure 13-7 Interconnection of digital signals (example)

Example 2: Connection of OC/OFF3 to several drives

The OFF3 signal should be connected to two drives via terminal DI 2 on the Control Unit. Each drive has the two binector inputs, "1st OFF3" and "2nd OFF3". The two signals are processed via an AND gate to STW1.2 (OFF3).

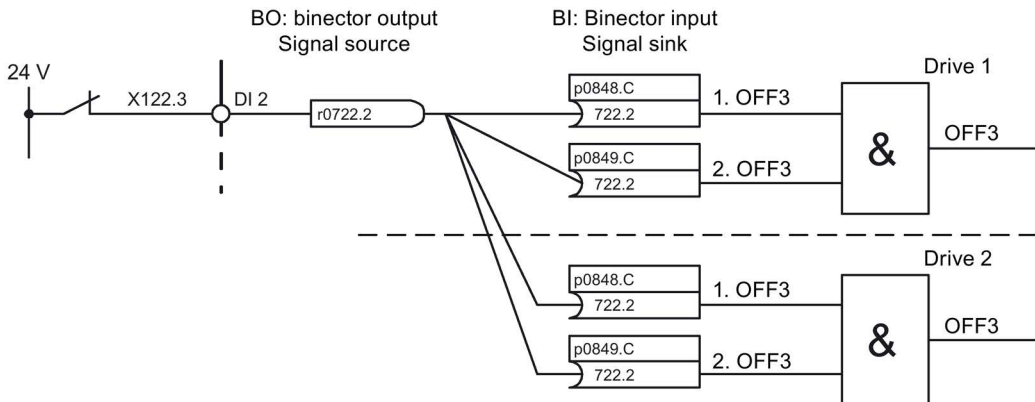

Figure 13-8 Connection of OFF3 to several drives (example)

13.4.5 Notes on BICO technology

BICO interconnections to other drives

The following parameters are available for BICO interconnections to other drives:

- r9490 Number of BICO interconnections to other drives
- r9491[0...9] BI/CI of BICO interconnections to other drives
- r9492[0...9] BO/CO of BICO interconnections to other drives
- p9493[0...9] Reset BICO interconnections to other drives

Copying drives

When a drive is copied, the interconnection is copied with it.

Binector-connector converters and connector-binector converters

Binector-connector converter

- Several digital signals are converted to a 32-bit integer double word or to a 16-bit integer word.
- p2080[0...15] BI: PROFIdrive PZD send bit-serial

Connector-binector converter

- A 32-bit integer double word or a 16-bit integer word is converted to individual digital signals.
- p2099[0...1] CI: PROFIdrive PZD selection receive bit-by-bit

Fixed values for interconnection using BICO technology

The following connector outputs are available for interconnecting any fixed value settings:

- p2900[0...n] CO: Fixed value_%_1
- p2901[0...n] CO: Fixed value_%_2
- p2930[0...n] CO: Fixed value_M_1

Example:

These parameters can be used to interconnect the scaling factor for the main setpoint or to interconnect an additional torque.

13.4.6 Scaling

Signals for the analog outputs

Table 13- 5 List of signals for analog outputs

Signal	Parameter	Unit	Scaling (100% = ...)
Speed setpoint before the setpoint filter	r0060	rpm	p2000
Actual speed value, motor encoder	r0061	rpm	p2000
Actual speed value	r0063	rpm	p2000
Drive output frequency	r0066	Hz	Reference frequency
Absolute actual current value	r0068	Arms	p2002
Actual DC-link voltage value	r0070	V	p2001
Total torque setpoint	r0079	Nm	p2003
Actual active power	r0082	kW	r2004
Control deviation	r0064	rpm	p2000
Modulation depth	r0074	%	Reference modulation depth
Torque-generating current setpoint	r0077	A	p2002
Torque-generating actual current value	r0078	A	p2002
Flux setpoint	r0083	%	Reference flux
Flux actual value	r0084	%	Reference flux
Speed controller PI torque output	r1480	Nm	p2003
Speed controller I torque output	r1482	Nm	p2003

Changing scaling parameters p2000 to p2007

Note

If a per unit representation is selected and the reference parameter is subsequently changed (e.g. p2000), the per unit values of some control parameters are automatically adapted so that the control behavior does not change.

13.4.7 Propagation of faults

In the case of faults that are, for example, triggered by the Control Unit or a Terminal Module, central functions of the drive are also often affected. As a result of propagation, faults that are triggered by one drive object are therefore forwarded to other drive objects.

This behavior also applies to the faults that are set in a DCC on the Control Unit with the aid of the DCC block.

There are the following types of propagation:

- BICO

The fault is propagated to all active drive objects with closed-loop control functions (infeed, drive) to which there is a BICO interconnection.

- DRIVE

The fault is propagated to all active drive objects with closed-loop control functions.

- GLOBAL

The fault is propagated to all active drive objects.

- LOCAL

The behavior of this propagation type is dependent on parameter p3116.

- With binector input p3116 = 0 (factory setting) the following applies:
The fault is propagated to the first active drive object with closed-loop control functions.
- With binector input p3116 = 1 signal, the following applies:
The fault is not propagated.

13.5 Inputs/outputs

The following digital/analog inputs/outputs are available:

Table 13- 6 Overview of inputs/outputs

Component	Digital			Analog	
	Inputs	Bidirectional in-puts/outputs	Outputs	Inputs	Outputs
CU320-2	12 ¹⁾	8 ²⁾	-	-	-
CU310-2	5+3 ³⁾	8+1 ³⁾	-	1	-
TB30	4	-	4	2	2
TM15DI_DO	-	24	-	-	-
TM31	8	4	-	2	2
	Relay outputs: 2 Temperature sensor input: 1				
TM41	4	4	-	1	-
	Incremental encoder emulation: 1				
TM120	Temperature sensor inputs: 4				

- 1) Adjustable: floating or non-floating
- 2) Six of these are "high-speed inputs"
- 3) Additional inputs for Safety Integrated Basic Functions

Note

Detailed information on the hardware properties of the inputs/outputs can be found in the SINAMICS S120 Control Units Manual.

For detailed information about the structural relationships between all I/Os of a component and their parameters, please refer to the function diagrams in the SINAMICS S120/S150 List Manual:

13.5.1 Digital inputs/outputs

Signal processing using the digital inputs is shown in the function diagrams listed below.

Properties

- The digital inputs are "high active".
- An open input is interpreted as "low".
- Fixed debounce setting.
Delay time = 1 to 2 current controller cycles (p0115[0])
- Availability of the input signal for further interconnection.
 - Inverted and not inverted as a binector output
 - As a connector output
- Simulation mode settable and parameterizable.
- Isolation block by block, set by jumper.
 - Jumper open: Isolated.
The digital inputs function only if a reference ground is connected.
 - Jumper closed, non-isolated.
The reference potential of the digital inputs is the ground of the Control Unit.
- Sampling time for digital inputs/outputs can be adjusted (p0799).

Function diagrams (see SINAMICS S120/S150 List Manual)

Control Unit 320-2

- 2120 CU320-2 input/output terminals - isolated digital inputs (DI 0...DI 3, DI 16, DI 17)
- 2121 CU320-2 input/output terminals - isolated digital inputs (DI 4...DI 7, DI 20, DI 21)

TB30

- 9100 Terminal Board 30 (TB30) - isolated digital inputs (DI 0 ... DI 3)

TM15

- 9550 Terminal Module 31 (TM31) - isolated digital inputs (DI 0 ... DI 3)
- 9552 Terminal Module 31 (TM31) - isolated digital inputs (DI 4 ... DI 7)

TM41

- 9660 Terminal Module 41 (TM41) - isolated digital inputs (DI 0 ... DI 3)

Control Unit 310-2

- 2020 CU310-2 input/output terminals - isolated digital inputs (DI 0 ... DI 3, DI 22)
- 2021 CU310-2 input/output terminals - isolated digital inputs (DI 16 ... DI 21)
- 2030 CU310-2 input/output terminals - digital input/outputs, bidirectional (DI/DO 8 ... DI/DO 9)
- 2031 CU310-2 input/output terminals - digital input/outputs, bidirectional (DI/DO 10 ... DI/DO 11)
- 2032 CU310-2 input/output terminals - digital input/outputs, bidirectional (DI/DO 12 ... DI/DO 13)
- 2033 CU310-2 input/output terminals - digital input/outputs, bidirectional (DI/DO 14 ... DI/DO 15)
- 2038 CU310-2 input/output terminals - digital output (DO 16)

Digital outputs

Signal processing using the digital outputs is shown in the function diagrams listed below.

Properties

- Separate power supply for the digital outputs.
- Source of output signal can be selected by parameter.
- Signal can be inverted by parameter.
- Status of output signal can be displayed
 - As a binector output
 - As a connector output

Note

Before the digital outputs can function, their own electronics power supply must be connected.

Function diagrams (see SINAMICS S120/S150 List Manual)

TB30

- 9102 Terminal Board 30 (TB30) -
isolated digital inputs (DI 0 ... DI 3)

TM31

- 9556 Terminal Module 31 (TM31) -
Digital relay outputs, electrically isolated (DO 0 ... DO 1)

Control Unit 310-2

- 2038 CU310-2 input/output terminals -
digital output (DO 16)

Bidirectional digital inputs/outputs

Signal processing using the bidirectional inputs/outputs is shown in the function diagrams listed below.

Properties

- Can be parameterized as digital input or output.
- When set as digital input:
 - Six "high-speed inputs" on Control Unit
 - If these inputs are used, for example, for the "flying measurement" function, they act as "high-speed inputs" with virtually no time delay when the actual value is saved.
 - The properties of the "pure" digital outputs apply.
- When set as digital output:
 - The properties of the "pure" digital outputs apply.
- Sharing of bidirectional input/output resources by the CU and higher-level controller (see Section "Use of bidirectional inputs/outputs on the CU (Page 934)")

Function diagrams (see SINAMICS S120/S150 List Manual)

Control Unit CU310-2

- 2030 CU310-2 input/output terminals -
digital input/outputs, bidirectional (DI/DO 8 ... DI/DO 9)
- 2031 CU310-2 input/output terminals -
digital input/outputs, bidirectional (DI/DO 10 ... DI/DO 11)
- 2032 CU310-2 input/output terminals -
digital input/outputs, bidirectional (DI/DO 12 ... DI/DO 13)
- 2033 CU310-2 input/output terminals -
digital input/outputs, bidirectional (DI/DO 14 ... DI/DO 15)

CU320-2 Control Unit

- 2130 CU320-2 input/output terminals -
digital input/outputs, bidirectional (DI/DO 8 and DI/DO 9)
- 2131 CU320-2 input/output terminals -
digital input/outputs, bidirectional (DI/DO 10 and DI/DO 11)
- 2132 CU320-2 input/output terminals -
digital input/outputs, bidirectional (DI/DO 12 and DI/DO 13)
- 2133 CU320-2 input/output terminals -
digital input/outputs, bidirectional (DI/DO 14 and DI/DO 5)

TM15

- 9400 Terminal Module 15 (TM15) -
digital inputs/outputs, bidirectional (DI/DO 0 ... DI/DO 7)
- 9401 Terminal Module 15 (TM15) -
digital inputs/outputs, bidirectional (DI/DO 8 ... DI/DO 15)
- 9402 Terminal Module 15 (TM15) -
digital inputs/outputs, bidirectional (DI/DO 16 ... DI/DO 23)

TM31

- 9560 Terminal Module 31 (TM31) -
digital inputs/outputs, bidirectional (DI/DO 8 and DI/DO 9)
- 9562 Terminal Module 31 (TM31) -
digital inputs/outputs, bidirectional (DI/DO 10 and DI/DO 1)

TM41

- 9661 Terminal Module 41 (TM41) -
digital inputs/outputs, bidirectional (DI/DO 0 and DI/DO 1)
- 9662 Terminal Module 41 (TM41) -
digital inputs/outputs, bidirectional (DI/DO 2 and DI/DO 3)

13.5.2 Use of bidirectional inputs/outputs on the CU

The bidirectional inputs/outputs of terminals X122 and X132 on the CU (DO1) can be used by a drive object as well as a higher-level controller (resource sharing).

The assignment to a terminal is defined by means of BICO interconnections which are either connected to a controller via the DO1 telegram p0922 = 39x or to a drive object.

The setting of parameter p0729 indicates how a digital output of a Control Unit has been assigned, i.e. whether the output of an onboard terminal X122 or X132 is assigned directly to the Control Unit or connected via PROFIBUS to a higher-level controller.

- r0729 = 0: The output is assigned to the Control Unit of the drive or terminal output not available.
- r0729 = 1: Output is assigned to the higher-level controller (PROFIBUS connection). Assignment to the controller means:
 - Terminal is parameterized as output x (p0728.x =1) and
 - Terminal is connected with p2901 via BICO, i.e. the control uses the output in conjunction with the DO1 telegram (p0922 = 39x)
 - Use of the terminal's output signal for integrated platform via high-speed bypass channel of the controller (standard channel with DO1 telegram is always written in parallel).
Parameter r0729 is updated if
- the direction of the onboard terminals changes over (p0728), or
- the signal sources for the outputs (p0738 ff) are changed.

Access priorities

- Reparameterization output controller --> output drive via parameter p0738 ff
The drive output has higher priority than a standard controller output using the DO1 telegram, but direct access by the controller to the terminal (bypass) has higher priority than the drive output.
When the output is reconfigured to the drive, the controller needs to cancel a bypass to the terminals (if one has been set up) before the new configuration can take effect.
- Reconfiguration input drive --> output controller
The output of the controller has higher priority. This is the specified behavior.
The drive is notified of the change so that the affected application can issue an alarm.
- Reconfiguration output drive --> output controller
The output of the controller has higher priority.
This is the specified behavior.
The drive is notified of the change so that the affected application can issue an alarm/fault message is necessary. Readback of the output information can cause problems in the drive, i.e. the drive application checks the interconnection condition of "its" terminals. If the terminal remains assigned to a drive I/O device as required by the drive function, but is assigned simultaneously a controller terminal status, the drive function cannot be guaranteed to work correctly.

Fault reaction to controller failure

The onboard I/Os assigned to the controller are switched to the safe state in response to a fault.

This also applies to terminals whose signals are transferred via the bypass channel of the controller. This status is signaled by failure of the DO1 telegram (sign-of-life failure).

13.5.3 Analog inputs

Signal processing using the analog inputs is shown in the function diagrams listed below.

Properties

- Hardware input filter set permanently
- Simulation mode parameterizable
- Adjustable offset
- Signal can be inverted via binector input
- Adjustable absolute-value generation
- Noise suppression (p4068)
- Enabling of inputs via binector input
- Output signal available via connector output
- Scaling
- Smoothing

Note

Parameters p4057 to p4060 of the scaling do not limit the voltage values / current values (for TM31, the input can be used as current input).

Analog input of Control Unit 310-2

Control Unit CU310-2 has an integrated analog input at terminal strip X131, terminals 7 and 8, an analog input. The input is preset as current or voltage input using DIP switch S5. The input can be further differentiated using p0756 [x]:

p0756[x]	Input function
0	0...10 V
2	0...20 mA
3	4...20 mA
4	-10 V to +10 V
5	-20 mA to +20 mA

The characteristic of the analog input can be scaled using parameters p0757 to P0760.

The value of the analog input can be read out from r0755.

Function diagrams (see SINAMICS S120/S150 List Manual)

- 9104 Terminal Board 30 (TB30) - Analog inputs (AI 0 ... AI 1)
 - 9566 Terminal Module 31 (TM31) - Analog input 0 (AI 0)
 - 9568 Terminal Module 31 (TM31) - Analog input 1 (AI 1)
 - 9663 Terminal Module 41 (TM41) - Analog input 0 (AI 0)
- CU310-2:**
- 2040 CU310-2 input/output terminals - Analog input (AI 0)

Overview of important parameters (see SINAMICS S120/S150 List Manual)

- r0752[0] CO: CU analog input current input voltage/current
 - p0753[0] CU analog input smoothing time constant
 - p0761[0] CU analog input wire-break monitoring response threshold
 - p0762[0] CU analog input wire-break monitoring delay time
 - p0763[0] CU analog input offset
 - p0766[0] CU analog input activate absolute-value generation
 - p0769[0] BI: CU analog input enable signal source
- CU310-2:**
- r0755[0] CO: CU analog input actual value in percent
 - p0756 [0] CU analog input type
 - p0757[0] CU analog input characteristic value x1
 - p0758[0] CU analog input characteristic value y1
 - p0759[0] CU analog input characteristic value x2
 - p0760[0] CU analog input characteristic value y2

13.5.4 Analog outputs

Signal processing using the analog outputs is shown in the function diagrams listed below.

Properties

- Adjustable absolute-value generation
- Inversion via binector input
- Adjustable smoothing
- Adjustable transfer characteristic
- Output signal can be displayed via visualization parameter

Note

Parameters p4077 to p4080 of the scaling do not limit the voltage values / current values (for TM31, the output can be used as current output).

Function diagrams (see SINAMICS S120/S150 List Manual)

- 9106 Terminal Board 30 (TB30) - Analog outputs (AO 0 ... AO 1)
- 9572 Terminal Module 31 (TM31) - Analog outputs (AO 0 ... AO 1)

13.6 Data backup

13.6.1 Backing up the non-volatile memory

For operation-relevant data, the CU320-2 and the CU310-2 have a non-volatile memory, the NVRAM (Non-Volatile Random Access Memory). The data of the fault buffer, the diagnostics buffer and message buffer is saved in this memory.

Certain circumstances, for example, a defect in the Control Unit or if the Control Unit has been replaced, require that this data is backed up. After the hardware has been replaced, transfer the backed up data back to the NVRAM of the Control Unit. You can perform these operations using parameter p7775:

1. Using p7775 = 1 backup the NVRAM data to a memory card.
2. Using P7775 = 2, copy NVRAM data from the memory card to the NVRAM.
3. Using P7775 = 3, delete the data in the NVRAM.
After the data has been successfully cleared, a POWER ON is automatically carried out.

p7775 is automatically set to 0 if the operation was successful. If the operation was not successful, p7775 indicates a corresponding fault value. Further details of the fault values can be found in the SINAMICS S120/S150 List Manual.

Note

NVRAM data change

The data in the NVRAM can only be restored or deleted if the pulse inhibit is set.

Backing up NVRAM data

With p7775 = 1, the NVRAM data of a stand-alone Control Unit is saved in the subdirectory: "... \USER\SINAMICS\NVRAM\PMEMORY.ACX" on the memory card.

When the Control Unit is integrated in a control system, the NVRAM data is saved in the subdirectory: "... \USER\SINAMICS\NVRAM\xx\PMEMORY.ACX" on the memory card. "xx" corresponds to the DRIVE CLiQ port.

When saving, all data is backed up from the NVRAM.

Note

Backing up NVRAM data

The backup of the NVRAM data to the memory card is also possible when the pulses are enabled. However, if the drive is operated when NVRAM data is being transferred, then it is possible that the backed up data is not consistent with the NVRAM data.

Restoring NVRAM data

With $p7775 = 2$, the NVRAM data is transferred back from the memory card into the Control Unit. When restoring you decide which data you require and want to copy.

There are two reasons that necessitate the NVRAM data being restored.

- Replacing the Control Unit.
- Specific restoration of the NVRAM data as it is possible that there are data errors.

When restoring, the Control Unit always searches first for the "PMEMORY.ACX" file. If the file is available with a valid checksum, then it is loaded.

Replacing the Control Unit:

If a Control Unit has to be replaced, then this is identified by SINAMICS as a result of the modified Control Unit serial number. After the POWER ON, the NVRAM of the Control Unit is first deleted. The new NVRAM data is then loaded.

NVRAM restoration:

A specific restoration of the saved NVRAM data is initiated by setting $p7775 = 2$. The original file in the NVRAM is first deleted. If the file "PMEMORY.ACX" is available with a valid checksum, it is loaded to the NVRAM.

The following data is not imported again:

- Control Unit operating hours counter
- Control Unit temperature
- Safety logbook
- Crash diagnostics data

Deleting NVRAM data

With p7775 = 3, the NVRAM data is deleted.

The following data is not deleted:

- Control Unit operating hours counter
- Control Unit temperature
- Safety logbook
- Crash diagnostics data

Note

NVRAM and know-how protection

Know-how protection and write protection apply to parameter p7775. If the parameter should be readable despite activated protection mechanisms, then p7775 must be placed in the exception list.

Note

NVRAM and write protection

When write protection is activated, p7775 can only be written to from a higher-level controller using cyclic communication.

More information on fault buffers, diagnostic buffers and message buffers is provided in the SINAMICS S120 Commissioning Manual.

13.6.2 Redundant data backup on memory card

In conjunction with the "Firmware download via Web server" and the associated remote access, the "Redundant data backup on memory card" provides safe access again to the device in the event of an interruption of the connection or the power supply. This redundant data backup cannot be deactivated.

As of firmware version V4.6, the memory cards have a backup partition in addition to the normal working partition. The most important data is duplicated on this backup partition during ramp-up of the CU. This ensures that when you update the data on the memory card a data loss cannot occur due to a power failure. Only the system can access this backup partition. The partition is not visible for users.

If damage to the file system is detected on the memory card, the system reconstructs the data on the working partition from the backup partition at the next ramp-up of the CU. The fault "F01072: memory card recreated from backup copy" is emitted. A running restoration of the data is indicated via the LEDs (FW Loading). Generally, the restoration of the data takes one minute.

The duplication of changed project data on the backup partition takes just a few seconds during ramp-up. After write operations on the working partition (e.g. RAM to ROM), the system automatically recognizes when an update of the backup copy on the backup partition is required and issues the message "A01073: POWER ON required for backup copy on

memory card". In this case, perform a POWER ON for the Control Unit or a hardware reset (via p0972).

As of firmware version V4.6, there may be a substantial data backup at the first ramp-up with a memory card. Generally, this data backup only takes a minute and is indicated via the LEDs (FW Loading). Such a data backup is also performed once for a firmware update or hotfix of the memory card via the card reader (as of V4.6).

 WARNING
Danger to life through software manipulation when using removable storage media
The storage of files on removable storage media involves a high risk of infection, e.g. via viruses or malware. As a result of incorrect parameterization, machines can malfunction, which in turn can lead to injuries or death.
<ul style="list-style-type: none"> • Protect the files on removable storage media against harmful software through appropriate protective measures, e.g. virus scanners.

Note

Minimum requirements

Use of this feature is not possible with memory cards of older firmware versions (e.g. V4.5). The following requirements must be satisfied for working with automatic backup copies:

- a Control Unit, correct version (see "Reading off CU version")
- an original memory card for firmware version V4.6 or higher

Note

Particularity of the firmware download via the Web server

In exceptional circumstances, memory cards with older firmware versions can be used for the firmware download via the Web server. However, there is no guarantee of retentive data storage.

Reading off the CU version

The following table lists the versions required to use the "Redundant data backup on memory card" for each Control Unit. The appropriate data is available on your CU type plate.

Control Unit	Version (PRODIS)
CU310-2 DP	≥ E
CU310-2 PN	≥ E
CU320-2 DP	≥ G
CU320-2 PN	≥ D

Overview of important faults and alarms (see SINAMICS S120/S150 List Manual)

- F01072 Memory card restored from backup copy
- A01073 POWER ON required for backup copy on memory card

13.7 Parameterizing using the BOP20 (Basic Operator Panel 20)

13.7.1 General information about the BOP20

The BOP20 can be used to switch on and switch off drives during the commissioning phase as well as to display and modify parameters. Faults can be diagnosed as well as acknowledged.

The BOP20 is snapped onto the Control Unit. To do this, the blanking cover must be removed (for additional information on mounting, please refer to the SINAMICS S120 Manual Control Units and Supplementary System Components).

Displays and keys

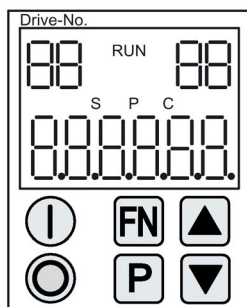

Figure 13-9 Overview of displays and keys







Information on the displays

Table 13-7 LED

Display	Meaning
top left 2 positions	The active drive object of the BOP is displayed here. The displays and key operations always refer to this drive object.
RUN	Lit if at least one drive in the drive line-up is in the RUN state (in operation). RUN is also displayed via bit r0899.2 of the drive.
top right 2 positions	The following is displayed in this field: <ul style="list-style-type: none"> • More than 6 digits: Characters that are still present but are invisible (e.g. "r2" → 2 characters to the right are invisible, "L1" → 1 character to the left is invisible) • Faults: Selects/displays other drives with faults • Designation of BICO inputs (bi, ci) • Designation of BICO outputs (bo, co) • Source object of a BICO interconnection to a drive object different than the active one.
S	Is (bright) if at least one parameter was changed and the value was not transferred into the non-volatile memory.
P	Is lit (bright) if, for a parameter, the value only becomes effective after pressing the P key.
C	Is light (bright) if at least one parameter was changed and the calculation for consistent data management has still not been initiated.
Below, 6 digit	Displays, e.g. parameters, indices, faults and alarms.

Information on the keys

Table 13- 8 Keys

Key	Name	Meaning
	ON	Powering up the drives for which the command "ON/OFF1" should come from the BOP. Binector output r0019.0 is set using this key.
	OFF	Powering down the drives for which the commands "ON/OFF1", "OFF2" or "OFF3" should come from the BOP. The binector outputs r0019.0, .1 and .2 are simultaneously reset when this key is pressed. After the key has been released, binector outputs r0019.1 and .2 are again set to a "1" signal. Note: The effectiveness of these keys can be defined by appropriately parameterizing the BICO (e.g. using these keys it is possible to simultaneously control all of the existing drives).
	Functions	The significance of this key depends on the actual display. Note: The effectiveness of this key to acknowledge faults can be defined using the appropriate BiCo parameterization.
	Parameter	The significance of this key depends on the actual display. If this key is pressed for 3 s, the "Copy RAM to ROM" function is executed. The "S" displayed on the BOP disappears.
	Raise	The significance of these keys is dependent on the actual display and is used to increase or decrease values.
	Lower	

BOP20 functions

Table 13-9 Functions

Name	Description
Backlighting	The backlighting can be set using p0007 in such a way that it switches itself off automatically after the set time if no actions are carried out.
Changeover active drive	From the BOP perspective the active drive is defined using p0008 or using the keys "FN" and "Arrow up".
Units	The units are not displayed on the BOP.
Access level	The access level for the BOP is defined using p0003. The higher the access level, the more parameters can be selected using the BOP.
Parameter filter	Using the parameter filter in p0004, the available parameters can be filtered corresponding to their particular function.
Selecting the operating display	Actual values and setpoints are displayed on the operating display. The operating display can be set using p0006.
User parameter list	Using the user parameter list in p0013, parameters can be selected for access.
Unplug while voltage is present	<p>The BOP can be withdrawn and inserted under voltage.</p> <ul style="list-style-type: none"> • The ON key and OFF key have a function. When withdrawing, the drives are stopped. After inserting, the drives must be switched on again. • The ON key and OFF key have no function. Withdrawing and inserting has no effect on the drives.
Actuating keys	<p>The following applies to the "P" and "FN" keys:</p> <ul style="list-style-type: none"> • When used in a combination with another key, "P" or "FN" must be pressed first and then the other key.

Overview of important parameters (see SINAMICS S120/S150 List Manual)

All drive objects

- p0005[0...1] BOP status display selection
- p0006 BOP status display mode
- p0013[0...49] BOP user-defined list
- p0971 Save drive object parameters

Drive object, Control Unit

- r0002 Control Unit status display
- p0003 BOP access level
- p0004 BOP display filter
- p0007 BOP backlighting
- p0008 BOP drive object after powering up
- p0009 Device commissioning parameter filter
- p0011 BOP password input (p0013)
- p0012 BOP password confirmation (p0013)
- r0019.0...14 CO/BO: Control word, BOP
- p0977 Save all parameters

Other drive objects (e.g. SERVO, VECTOR, X_INF, TM41 etc.)

- p0010 Drive, commissioning parameter filter

13.7.2 Displays and using the BOP20

Features

- Status indicator
- Changing the active drive object
- Displaying/changing parameters
- Displaying/acknowledging faults and alarms
- Controlling the drive using the BOP20

Status indicator

The operating display for each drive object can be set using p0005 and p0006. Using the operating display, you can change into the parameter display or to another drive object. The following functions are possible:

- Changing the active drive object
 - Press key "FN" and "Arrow up" -> the drive object number at the top left flashes
 - Select the required drive object using the arrow keys
 - Acknowledge using the "P" key
- Parameter display
 - Press the "P" key.
 - The required parameters can be selected using the arrow keys.
 - Press the "FN" key -> "r00000" is displayed
 - Press the "P" key -> changes back to the operating display

Parameter display

The parameters are selected in the BOP20 using the number. The parameter display is reached from the operating display by pressing the "P" key. Parameters can be searched for using the arrow keys. The parameter value is displayed by pressing the "P" key again. You can toggle between the drive objects by simultaneously pressing the "FN" key and an arrow key. You can toggle between "r00000" and the parameter that was last displayed by pressing the "FN" key in the parameter display.

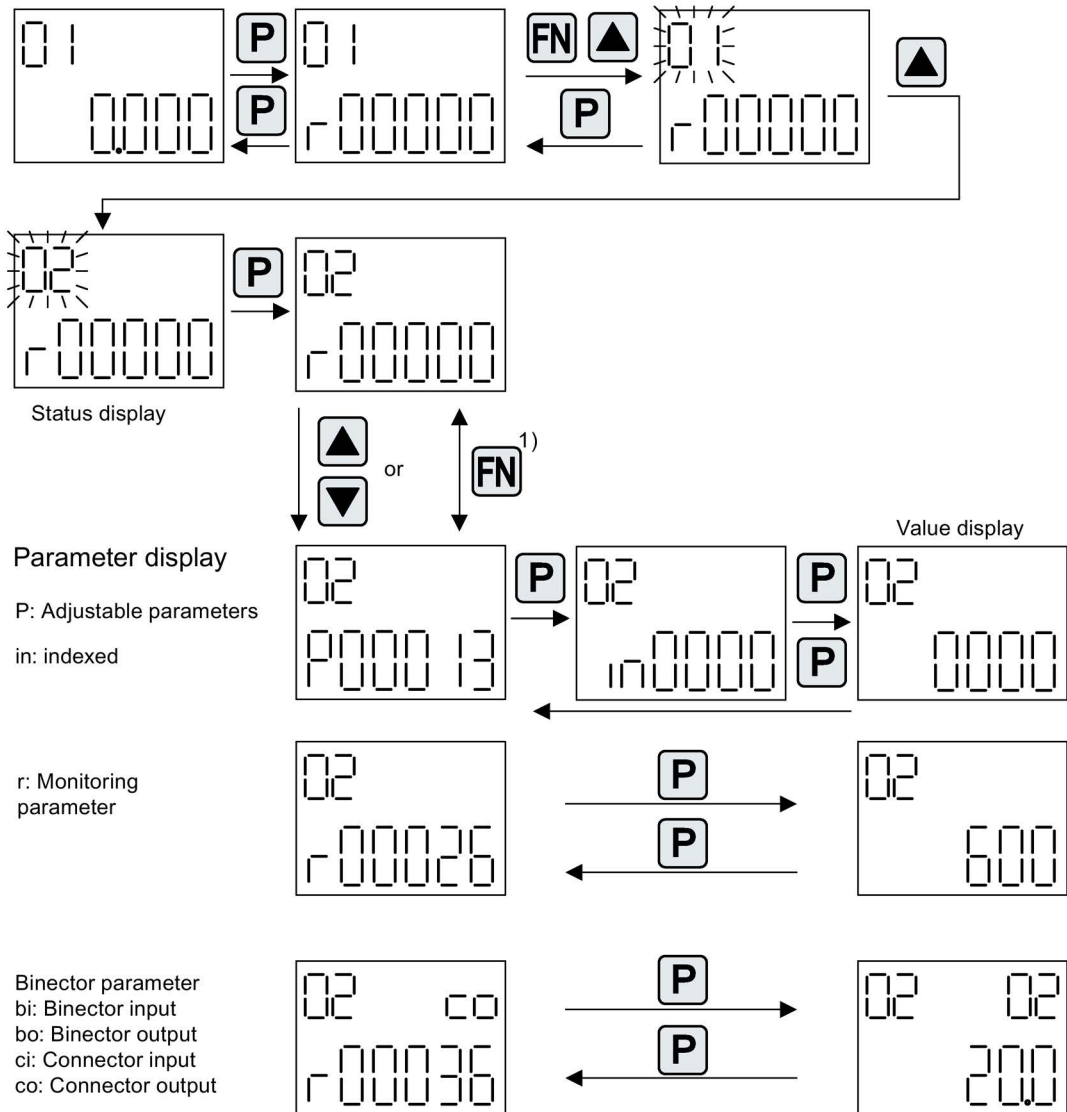

1) You can switch between "r00000" and the parameter that was last displayed by pressing the FN key in the parameter display.

Figure 13-10 Parameter display

Value display

To switch from the parameter display to the value display, press the "P" key. In the value display, the values of the adjustable parameters can be increased and decreased using the arrow. The cursor can be selected using the "FN" key.

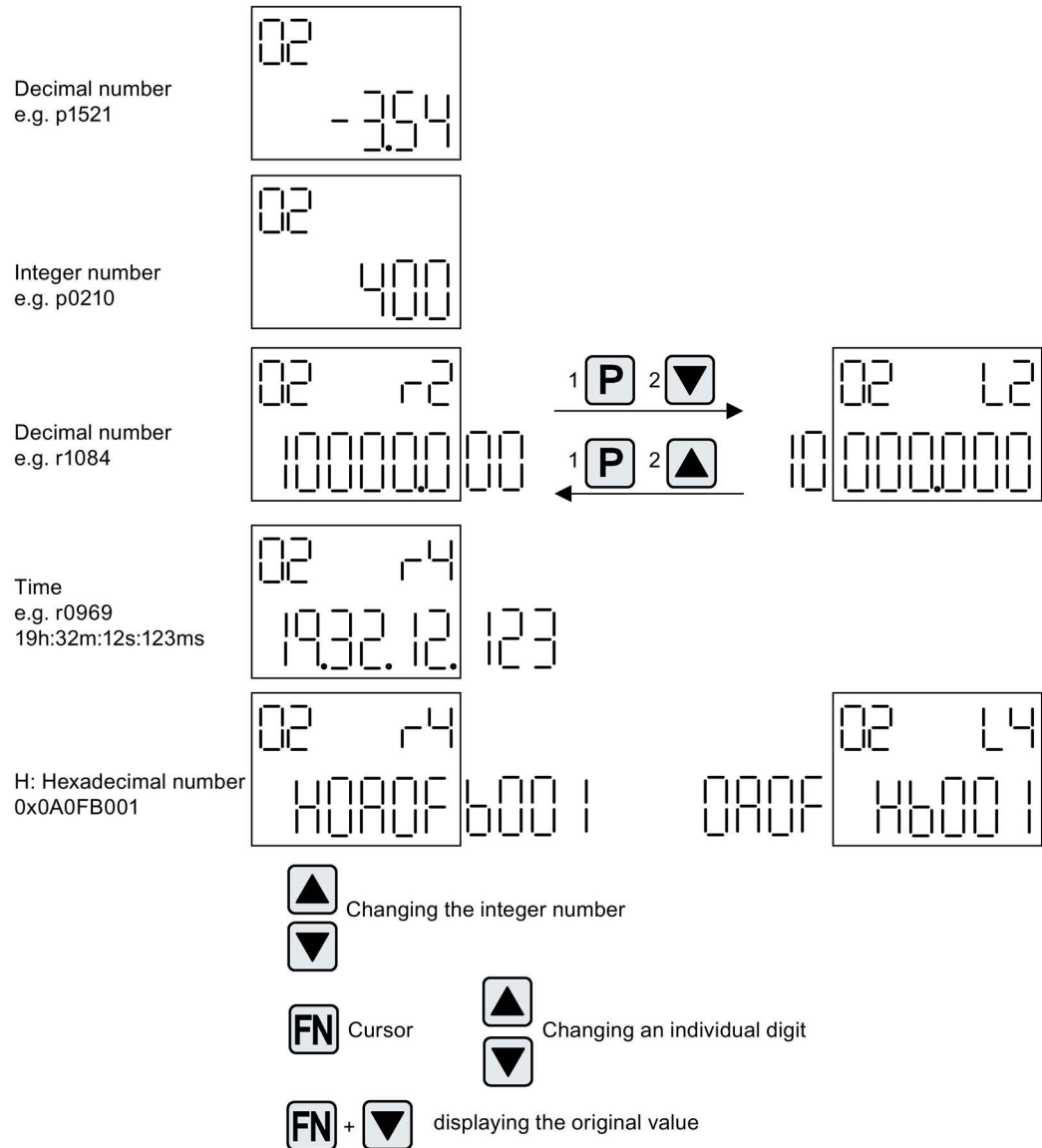

Figure 13-11 Value display

Example: Changing a parameter

Precondition: The appropriate access level is set
(for this particular example, p0003 = 3).

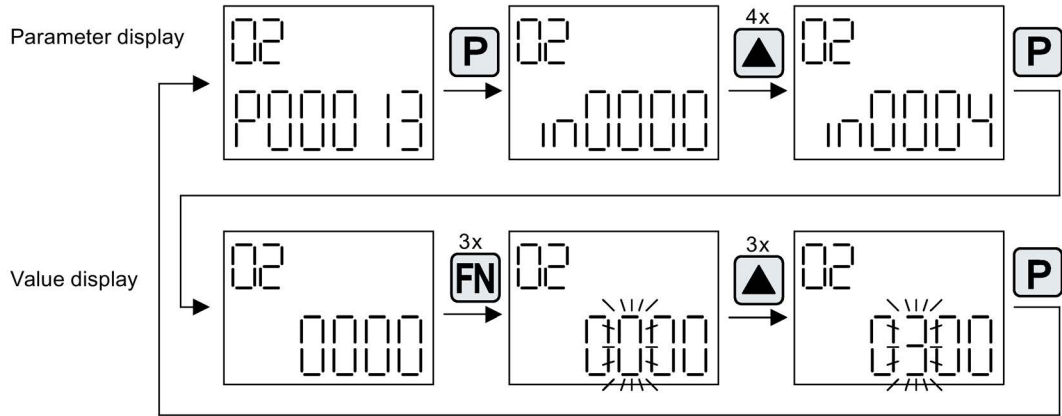

Figure 13-12 Example: Changing p0013[4] from 0 to 300

Example: Changing binector and connector input parameters

For the binector input p0840[0] (OFF1) of drive object 2 binector output r0019.0 of the Control Unit (drive object 1) is interconnected.

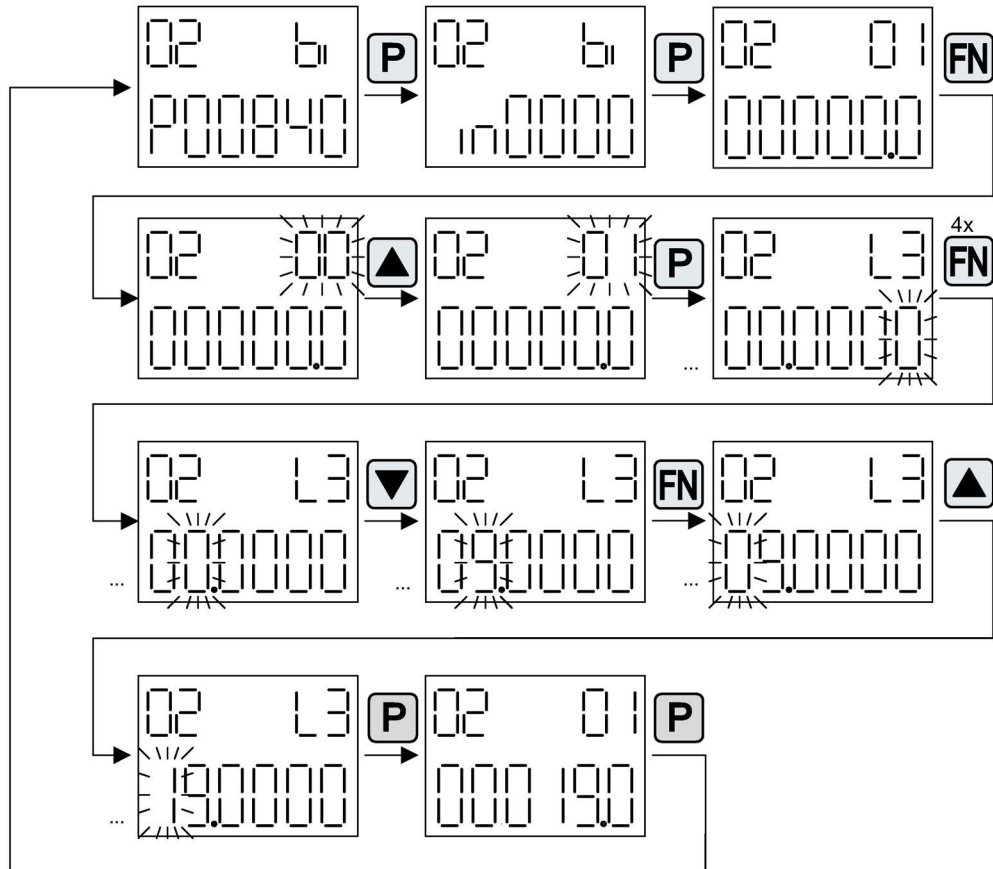

Figure 13-13 Example: Changing indexed binector parameters

13.7.3 Fault and alarm displays

Displaying faults

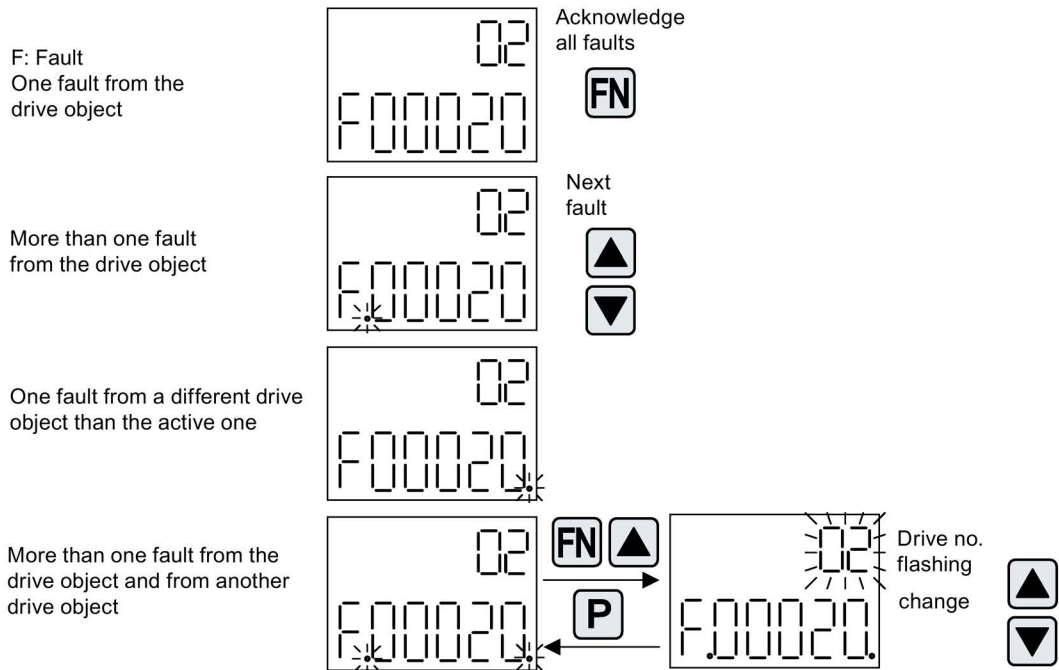

Figure 13-14 Faults

Displaying alarms

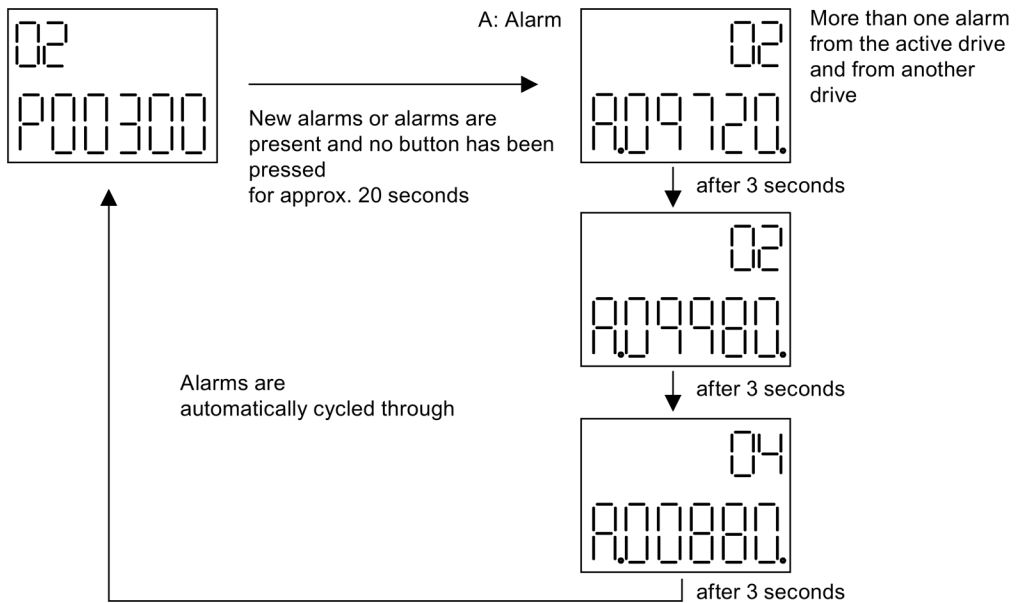

Figure 13-15 Alarms

13.7.4 Controlling the drive using the BOP20

When commissioning the drive, it can be controlled via the BOP20. A control word is available on the Control Unit drive object (r0019) for this purpose, which can be interconnected with the appropriate binector inputs of e.g. the drive.

The interconnections do not function if a standard PROFIdrive telegram was selected as its interconnection cannot be disconnected.

Table 13- 10 BOP20 control word

Bit (r0019)	Name	Example, interconnection parameters
0	ON / OFF (OFF1)	p0840
1	No coast down/coast down (OFF2)	p0844
2	No fast stop/fast stop (OFF3)	p0848
7	Acknowledge fault (0 -> 1)	p2102
13	Motorized potentiometer, raise	p1035
14	Motorized potentiometer, lower	p1036

Note

For simple commissioning, only bit 0 should be interconnected. When interconnecting bits 0 ... 2, then the system is powered-down according to the following priority: OFF2, OFF3, OFF1.

13.8 Examples of replacing components

Note

To ensure that the entire functionality of a firmware version can be used, it is recommended that all the components in a drive line-up have the same firmware version.

Description

If the type of comparison is set to the highest setting, the following examples apply.

A distinction is made between the following scenarios:

- A component with a different article number
- Components with identical article numbers
 - Topology comparison component replacement active (p9909 = 1)
 - Topology comparison component replacement inactive (p9909 = 0)

When p9909 = 1, the serial number and the hardware version of the new replacement component are automatically transferred from the actual topology to the reference topology, and then saved in the non-volatile memory.

When p9909 = 0, serial numbers and hardware versions are not automatically transferred. In this case, when the data in the electronic rating plate match, the transfer is realized using p9904 = 1 or p9905 = 1.

For the components that have been replaced, the electronic rating plate must match as far as the following data is concerned:

- Component type (e.g. "SMC20")
- Article number (e.g. "6SL3055-0AA00-5B..")

Example: Replacing a component with different article number**Requirement:**

- The replaced component has a different article number

Table 13- 11 Example: Replacing a component with different article number

Action	Reaction	Remark
<ul style="list-style-type: none"> • Switch off the power supply • Replace the defective component and connect the new one • Switch on the power supply 	<ul style="list-style-type: none"> • Alarm A01420 	
<ul style="list-style-type: none"> • Load the project from the Control Unit to the STARTER (PG) • Configure the replacement drive and select the current component • Load the project to the Control Unit (target system) 	<ul style="list-style-type: none"> • Alarm disappears 	The new article number is stored in the RAM of the Control Unit and has to be copied to the non-volatile memory with p0977 = 1 and p0971 = 1. As an alternative, STARTER can be used to backup data with a RAM to ROM operation.
The component has been successfully replaced.		

Example: (p9909 = 1) replacing a defective component with an identical article number**Requirement:**

- The replaced component has an identical article number
- The serial number of the new replacement component must not be contained in the stored target topology of the Control Unit.
- Topology comparison component replacement active p9909 = 1.

Sequence:

During startup of the Control Unit, the serial number of the new component is automatically transferred to the target topology and saved.

Example: (p9909 = 0) replacing a defective component with an identical article number

Requirement:

- The replaced component has an identical article number
- Topology comparison component replacement inactive p9909 = 0.

Table 13- 12 Example: Replacing a Motor Module

Action	Reaction	Remark
<ul style="list-style-type: none"> • Switch off the power supply • Replace the defective component and connect the new one • Switch on the power supply 	<ul style="list-style-type: none"> • Alarm A01425 	
<ul style="list-style-type: none"> • Set p9905 to "1" 	<ul style="list-style-type: none"> • Alarm disappears • The serial number is copied to the target topology 	The serial number is stored in the RAM of the Control Unit and has to be copied to the non-volatile memory with p0977 = 1 and p0971 = 1. As an alternative, STARTER can be used to backup data with a RAM to ROM operation.
The component has been successfully replaced.		

Example: Replacing a Motor Module/Power Module with a different power rating**Requirements:**

- The replaced power unit has a different power rating
- Vector: Power rating of the Motor Module/Power Module not greater than 4 * motor current

Table 13- 13 Example: Replacing a power unit with a different power rating

Action	Reaction	Remark
<ul style="list-style-type: none"> • Switch off the power supply • Replace the defective component and connect the new one • Switch on the power supply 	<ul style="list-style-type: none"> • Alarm A01420 	
<ul style="list-style-type: none"> • Drive object CU: <ul style="list-style-type: none"> – p0009 = 1 – p9906 = 2 – p0009 = 0 – p0977 = 1 	<ul style="list-style-type: none"> • Device configuration • Component comparison • Completing the configuration • Data backup 	For p9906 = 2: Caution Topology monitoring for all (!) components has been significantly reduced, so that if DRIVE-CLiQ lines are accidentally changed over this will not be detected.
<ul style="list-style-type: none"> • Drive object component: <ul style="list-style-type: none"> – p0201 = r0200 – p0010 = 0 – p0971 = 1 	<ul style="list-style-type: none"> • Use the code number • Completing commissioning • Data backup 	The new article number is stored in the RAM of the Control Unit and has to be copied to the non-volatile memory with p0977 = 1 and p0971 = 1. As an alternative, STARTER can be used to backup data with a RAM to ROM operation.
The component has been successfully replaced.		

Replacing motors with SINAMICS Sensor Module Integrated or with DRIVE-CLiQ Sensor Integrated

If a defect has occurred in a motor with integrated DRIVE-CLiQ interface (SINAMICS Sensor Module Integrated), please contact the Siemens office in your region to arrange for repair.

13.9 Notes on DRIVE-CLiQ topology

The term "topology" is used in SINAMICS to refer to a wiring harness with DRIVE-CLiQ cables. A unique component number is allocated to each component during the start-up phase.

DRIVE-CLiQ (Drive Component Link with IQ) is a communication system for connecting various components in SINAMICS (e.g. Control Unit, Line Module, Motor Module, motor and encoder).

DRIVE-CLiQ supports the following properties:

- Automatic detection of components by the Control Unit
- Standard interfaces to all components
- Standardized diagnostics down to component level
- Standardized service down to component level

Electronic rating plate

The electronic rating plate contains the following data:

- Component type (e.g. SMC20)
- Article number (e.g. 6SL3055-0AA0-5BA0)
- Manufacturer (e.g. SIEMENS)
- Hardware version (e.g. A)
- Serial number (e.g. "T-PD3005049)
- Technical specifications (e.g. rated current)

Actual topology

The actual topology corresponds to the actual DRIVE-CLiQ wiring harness.

When the drive system components are started up, the actual topology is detected automatically via DRIVE-CLiQ.

Target topology

The target topology is stored on the memory card on the Control Unit and is compared with the actual topology when the Control Unit is started up.

The target topology can be specified in two ways and saved on the memory card:

- Using STARTER
by creating the configuration and loading it onto the drive
- Using quick commissioning (automatic configuration):
the actual topology is read and the target topology written to the memory card

Comparison of topologies at Power On

Comparing the topologies prevents a component from being controlled/evaluated incorrectly (e.g. drive 1 and 2).

When the drive system boots, the Control Unit compares the detected actual topology and the electronic rating plates with the target topology stored on the memory card.

You can specify how the electronic rating plates are compared for all the components of a Control Unit via p9906. The type of comparison can be changed subsequently for each individual component. You can use p9908 for this or right-click in the topology view in the STARTER tool. All data on the electronic rating plate is compared by default.

The following data in the target and actual topologies is compared depending on the settings made in p9906/9908:

- p9906/p9908 = 0 component type, article number, manufacturer, serial number
- p9906/p9908 = 1 component type, article number
- p9906/p9908 = 2 component type
- p9906/p9908 = 3 component class (e.g. Sensor Module or Motor Module)

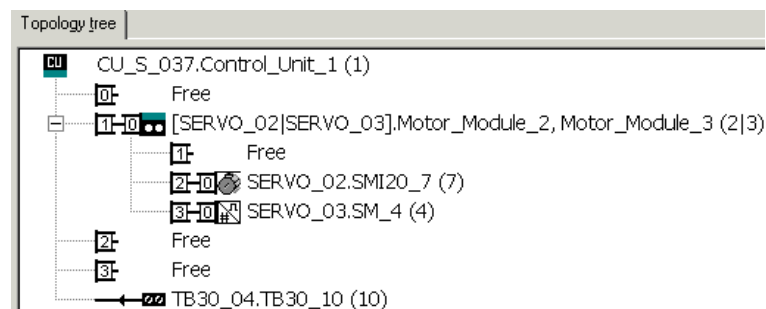

Figure 13-16 Topology view in STARTER

Note

The Control Unit and the Option Board are not monitored. A replacement of components is accepted automatically and not displayed.

13.10 System rules, sampling times and DRIVE-CLiQ wiring

13.10.1 Overview of system limits and system utilization

The number and type of controlled axes, infeeds and Terminal Modules as well as the additionally activated functions can be scaled by configuring the firmware.

Note

The subsequently described rules are applicable for both the STARTER and Startdrive commissioning tools. This is the reason that only the "Commissioning tool" term is used.

The software and control functions available in the system are executed cyclically with different sampling times (p0115, p0799, p4099). These sampling times are automatically pre-assigned when configuring the drive (see Section Default setting (Page 967)). They can be subsequently adapted by the user.

The number of controllable drives, infeeds and Terminal Modules that can be operated with the selected Control Unit depends on some system rules, the set sampling times, the control mode and the activated additional functions.

There are also still dependencies and rules for the components used and the selected DRIVE-CLiQ wiring.

The existing rules are described in greater detail in the following sub-sections. After this there are notes on the number of controllable drives and some example topologies.

The following standard quantity structures are operable with standard clock cycles:

- 12 V/f control axes with 500 μ s
- 6 vector axes with 500 μ s
- 6 servo axes with 125 μ s
- 3 vector axes with 250 μ s
- 3 servo axes with 62.5 μ s
- 1 servo axis with 31.25 μ s (single-axis module)

Consequently, the conversion of an axis from 125 μ s to 62.5 μ s normally leads to the loss of an axis. This rule can also be used for the clock-cycle mixing to achieve a general estimate of the quantity structure.

Especially for demanding configurations, drives with high dynamic response or a large number of axes with additional utilization of special functions for example, a check using the SIZER engineering tool is recommended. The SIZER engineering tool calculates the feasibility of the project.

Finally, the utilization flag in r9976 indicates whether a topology is operable. If the utilization exceeds 100%, this is indicated with fault F01054. In this case, one or more axes must be dispensed with or the function scope reduced.

13.10.2 System rules

A maximum of 24 drive objects (DOs) can be connected to one Control Unit.

Control Units

- The CU310-2 Control Unit is a single-axis control module for operating the AC/AC Power Modules in the Blocksize (PM240-2 or PM340) and Chassis formats. Terminal Modules, Sensor Modules and HUB Modules can also be connected in addition to these.
- The CU320-2 Control Unit is a multi-axis control module for operating Infeed Modules and Motor Modules in Booksize, Chassis and Blocksize formats. Terminal Modules, Sensor Modules and HUB Modules can also be connected in addition to these.

Motor Modules/control modes

For the CU310-2 Control Unit the following applies:

- The CU310-2 Control Unit is a single-axis control module (servo control, vector control or vector control V/f control) plugged into a PM240-2 or PM340 Power Module, or for operation with a maximum of one AC/AC Power Module in the Chassis format (via the X100 DRIVE-CLiQ connection).

For the CU320-2 Control Unit the following applies:

- The CU320-2 Control Unit is a multi-axis control module for operating Motor Modules in the Booksize, Chassis and Blocksize formats (PM240-2 and PM340 via CUA).
- For multi-axis modules, each axis counts individually (one Double Motor Module = two Motor Modules).
- A maximum of 6 drive objects may be operated concurrently in servo control and HLA control.
- There can be a maximum of 12 drive objects of the VECTOR type present concurrently.
 - A maximum of 6 drive objects can be operated concurrently in vector control.
 - A maximum of 12 drive objects can be operated concurrently with U/f control.
- Mixed operation of control types:
 - The following are permitted:
 - Mixed operation of servo control and V/f control.
 - Mixed operation of vector control and V/f control.
 - Mixed operation of HLA and servo control.
 - Mixed operation of HLA and vector control and V/f control.
 - The following are not permitted:
 - Mixed operation of servo control and vector control.
 - Mixed operation of HLA and servo control and V/f control.

The following applies when connecting Motor Modules in parallel:

- A parallel connection is only permitted in the chassis format and only in the vector control or V/f control mode.
- A maximum of four Motor Modules are permitted in a parallel connection. All Motor Modules connected in parallel must have the same output.
- A drive object is created for a parallel connection.
- Only one parallel connection exactly is permitted per Control Unit.

Line Modules

For the CU310-2 Control Unit the following applies:

- Operating Line Modules is not permitted

For the CU320-2 Control Unit the following applies:

- Only one drive object of the Smart Line Module (SLM), Basic Line Module (BLM) and Active Line Module (ALM) types is permitted in each case.
- Mixed operation of an Active Line Module with a Smart Line Module (SLM) or with a Basic Line Module (BLM) is not permitted.
- Mixed operation of a drive object of the Smart Line Module (SLM) type with a drive object of the Basic Line Module (BLM) type is permitted.
- An active Voltage Sensing Module (VSM) must be assigned to each active Active Line Module (ALM) or Smart Line Module (SLM) of the chassis format. A violation of this rule causes fault F05061 to be issued.
- Two further Voltage Sensing Modules can be operated with the "network transformer" function module for Active Line Modules (ALM).

The following applies to parallel connection of Line Modules:

- Parallel connection is permitted for Infeed Modules in the chassis format and for Active Line Modules (ALM) from the 120 kW performance class for the booksize format.
- A maximum of four Infeed Modules are permitted within a parallel connection.
- In booksize format, a maximum of two Active Line Modules (ALM) from the 120 kW performance class are permitted within a parallel connection.
- The operation of Infeed Modules with different performance values is not permitted within a parallel connection.
- An active Voltage Sensing Module (VSM) must be assigned to each Active Line Module (ALM) in the parallel connection. A violation of this rule causes alarm F05061 to be issued.
- When using Smart Line Modules (SLM) an active Voltage Sensing Module (VSM) must be assigned to at least one Smart Line Module (SLM) in the parallel connection. A violation of this rule causes fault F05061 to be issued.

Terminal Modules

Control Unit CU320-2:

- In total a maximum of 16 drive objects of the types TM15 Base, TM31, TM15, TM17, TM41, TM120 or TM150 can be operated concurrently.
- A maximum of one F Terminal Module (TM54F) can be connected (in addition).

Control Unit CU310-2:

- In total a maximum of eight drive objects of the types TM15 Base, TM31, TM15, TM17, TM41, TM120 or TM150 can be operated concurrently.
- A maximum of three drive objects of the types TM15, TM17 and TM41 may be operated concurrently in each case.
- A maximum of one F Terminal Module (TM54F) can be connected (in addition).

DRIVE-CLiQ Module (HUB)

- A maximum of eight drive objects can be operated concurrently for a DRIVE-CLiQ Module (DMC20 or DME20). DMC20/DME20 do not count twice here.

13.10.3 Rules on the sampling times**13.10.3.1 Rules when setting the sampling times**

The following rules apply when setting the sampling times:

General rules

- There are a maximum 2 possible cycle levels on the Control Unit, where the lowest sampling times are not integer multiples with respect to one another. All sampling times set must be an integer multiple of the smallest sampling time from one of these two cycle levels.

Example 1:

- Smallest sampling time cycle level 1: Active Line Module with 250 μ s
- Smallest sampling time cycle level 2: One VECTOR drive object with 455 μ s (p0113 = 1.098 kHz)

This setting is permitted.

Additional sampling times must be integer multiples of 250 μ s or 455 μ s.

Terminal Modules, Terminal Board, Control Unit:

- For the digital and analog inputs/outputs of these components the minimum sampling time (p0799, p4099, p0115) set must be 125 μ s.

Pulse frequencies and current controller sampling times:

- The current controller sampling times of the drives and infeeds must be synchronous to the set pulse frequency of the power unit (see also p1800 in the SINAMICS S120/S150 Lists Manual). Any increase in the pulse frequency requires a reduction in the sampling times and increases the derating in the power unit.

Line Modules

- For Active Line Modules (ALM) and Smart Line Modules (SLM) in booksize format the only current controller sampling time which can be set is 125 μ s or 250 μ s.
- For Active Line Modules (ALM) and Smart Line Modules (SLM) in chassis format the permitted current controller sampling time depends on the relevant module. The current controller sampling time can either only be set to 250 μ s or the current controller sampling time selected can be 400 μ s or 375 μ s (375 μ s for p0092 = 1).
- For Basic Line Modules (BLM) the only current controller sampling time which can be set is 2000 μ s (chassis format) or 250 μ s (booksize format).

Motor Modules

- For Single Motor Modules in booksize format, a current controller sampling time of minimum 31.25 μ s can be set ($31.25 \mu\text{s} \leq p0115[0] \leq 500 \mu\text{s}$).
- For Double Motor Modules in booksize format, a current controller sampling time of minimum 62.5 μ s can be set ($62.5 \mu\text{s} \leq p0115[0] \leq 500 \mu\text{s}$).
- For Motor Modules in chassis format, a current controller sampling time of minimum 125 μ s can be set ($125 \mu\text{s} \leq p0115[0] \leq 500 \mu\text{s}$).
- For Motor Modules in blocksize format, a current controller sampling time of 62.5 μ s, 125 μ s, 250 μ s or 500 μ s can be set (only pulse frequencies in multiples of 2 kHz are permissible).

For PM240-2 FS D-F the minimum current controller sampling time is 125 μ s.

- For the HLA module, a current controller sampling time of minimum 62.5 μ s can be set ($62.5 \mu\text{s} \leq p0115[0] \leq 250 \mu\text{s}$).

Servo control / HLA control

- A current controller sampling time between 31.25 μ s and 250 μ s can be set for servo drives ($31.25 \mu\text{s} \leq p0115[0] \leq 250 \mu\text{s}$).
- For HLA drives, a current controller sampling time between 62.5 μ s and 250 μ s can be set ($62.5 \mu\text{s} \leq p0115[0] \leq 250 \mu\text{s}$).
- The fastest sampling time for a drive object in servo control or HLA is as follows:
 - $T_i = 31.25 \mu\text{s}$: Exactly one drive object in servo control
 - $T_i = 62.5 \mu\text{s}$: Max. three drive objects in servo control or HLA
 - $T_i = 125 \mu\text{s}$: Max. six drive objects in servo control or HLA

Vector control / V/f control

- A current controller sampling time between 125 μs and 500 μs can be set for vector drives ($125 \mu\text{s} \leq p0115[0] \leq 500 \mu\text{s}$). This also applies to operation with V/f control.
- For vector control and vector control, V/f control modes, and when using a sine-wave filter ($p0230 > 0$), it is only permissible to change the current controller sampling time of the DO involved in multiple integer steps of the default value on account of the design of the sine-wave filter.
- The fastest sampling time of a drive object in vector control mode is obtained as follows:
 - $T_i = 250 \mu\text{s}$: Max. three drive objects in vector control
 - $T_i = 375 \mu\text{s}$: Max. four drive objects in vector control
 - $T_i = 400 \mu\text{s}$: Max. five drive objects in vector control
 - $T_i = 500 \mu\text{s}$: Max. six drive objects in vector control

Note**Restriction of the number of axes for chassis in vector control**

For active edge modulation / optimized pulse patterns and active wobbling, only half the number of axes is permitted.

- The fastest sampling time of a drive object in V/f control mode is obtained as follows:
 - $T_i = 500 \mu\text{s}$: Max. 12 drive objects in V/f control mode
- When vector control is operated together with vector control, V/f control, a maximum of 11 axes is possible (ALM, TB and TM additionally possible).

Safety functions

- Only Single Motor Modules are permitted for servo axes with a current controller cycle $T_{IReg} \leq 62.5 \mu\text{s}$ with the "Safety sensorless" functionality.

13.10.3.2 Rules for isochronous mode

Note

PROFIBUS legend

T_{dp} = PROFIBUS cycle (also DP cycle)

T_{mapc} = master application cycle time

T_i = Input Time (German time of incorporation of actual value)

T_o = Output Time (German time for setpoint value specification)

The following supplementary conditions must be observed for isochronous operation:

- The PROFIBUS cycle T_{dp} must be an integer multiple of 250 μ s.
- The PROFIBUS cycle T_{dp} must be an integer multiple of the current controller cycle.
- The times T_i (time of incorporation of actual value) and T_o (time for setpoint value specification) must be integer multiples of 125 μ s.
- The times T_i and T_o must be an integer multiple of the current controller cycle.
- T_{mapc} is an integer multiple of the speed controller cycle.
- Because T_i and T_o are always predefined for a PROFIBUS line, all drives of a Control Unit are affected and run with the same setting.
- p0092 = 1 (isochronous operation preassignment/validation) sets default values for the controller cycles for isochronous PROFIdrive operation during the initial commissioning.
 - The current controller cycles from "Table 13-18 Pulse frequencies and current controller cycles for servo control (Page 983)" can be set for servo control.
 - The current controller cycles from "Table 13-20 Pulse frequencies and current controller cycles for vector control (Page 984)" can be set for vector control.
- The setting rules for the safety actual value acquisition cycle and the safety monitoring cycle must be observed (for details, see SINAMICS S120 Safety Integrated Function Manual):
 - The monitoring cycle (p9500) must be an integer multiple of the actual value acquisition cycle (p9511). For p9511 = 0, the isochronous PROFIBUS cycle T_{dp} is used as the actual value acquisition cycle.
 - Actual value acquisition cycle $\geq 4 \times$ current controller cycle.
 - The DP cycle should be at least one current controller cycle longer than the sum of T_i and T_o .

The above conditions mean that the smallest common multiple of the current controller cycles of all axes operated on the isochronous PROFIBUS and 125 μ s is used to set T_i , T_o and T_{dp} .

If isochronous operation is not possible due to incorrect sampling time settings, an appropriate message will be output (A01223, A01224).

Cycle settings for SINAMICS Link

SINAMICS Link permits only three cycle settings:

Table 13- 14 Settings for activated isochronous operation

T_i [μ s]	T_o [μ s]	T_{dp} [μ s]
500	500	500
500	1000	1000
1500	1500	1500

13.10.3.3 Default settings for the sampling times

The sampling times of the functions are pre-assigned automatically when the drive is configured.

These default settings are based on the selected mode (vector/servo control) and the activated functions.

If isochronous mode is to be possible with a controller, before the automatic configuration, parameter p0092 must be set to "1" in order that the sampling times are appropriately preset. If isochronous operation is not possible due to incorrect sampling time settings, an appropriate message will be output (A01223, A01224).

If the application requires a change of the preset sampling times, they can be set using parameters p0112 and p0113 or directly using p0115, p0799 and p4099.

Note

Recommendation

Only appropriately qualified experts should change the sampling times set as default values.

When commissioning for the first time, the current controller sampling times (p0115[0]) are automatically preset with factory setting values:

Table 13- 15 Factory settings

Construction type	Number	p0112	p0115[0]	p1800
Active Infeed				
Booksize	1	2 (Low)	250 μ s	-
Chassis 400 V / \leq 300 kW	1	2 (Low)	250 μ s	-
690 V / \leq 330 kW	1	2 (Low)	250 μ s	-
Chassis 400 V / $>$ 300 kW	1	0 (Expert)	375 μ s (p0092 = 1)	-
690 V / $>$ 330 kW	1	1 (xLow)	400 μ s (p0092 = 0)	-

13.10 System rules, sampling times and DRIVE-CLiQ wiring

Construction type	Number	p0112	p0115[0]	p1800
Smart Infeed				
Booksize	1	2 (Low)	250 µs	-
Chassis				
400 V / ≤ 355 kW	1	2 (Low)	250 µs	-
690 V / ≤ 450 kW	1	2 (Low)	250 µs	-
Chassis				
400 V / > 355 kW	1	0 (Expert)	375 µs (p0092 = 1)	-
690 V / > 450 kW	1	1 (xLow)	400 µs (p0092 = 0)	-
Basic Infeed				
Booksize	1	4 (High)	250 µs	-
Chassis	1	2 (Low)	2000 µs	-
SERVO				
Booksize	1 ... 6	3 (Standard)	125 µs	4 kHz
Chassis	1 ... 6	1 (xLow)	250 µs	2 kHz
Blocksize	1 ... 5	3 (Standard)	125 µs	4 kHz
VECTOR				
Booksize	1 ... 3 only n_ctrl	3 (Standard)	250 µs	4 kHz
Chassis	1 ... 6 only U/f			2 kHz
Booksize	4 ... 6 only n_ctrl	0 (Expert)	500 µs	4 kHz
Chassis	7 ... 12 only f_ctrl			2 kHz
Chassis	1 ... 4 only n_ctrl	0 (Expert)	375 µs (p0092 = 1)	1.333 kHz
400 V / > 250 kW	1 ... 5 only U/f	1 (xLow)	400 µs (p0092 = 0)	1.25 kHz
690 V	5 ... 6 only n_ctrl	0 (Expert)	500 µs (p0092 = 1)	1.0 kHz

Note

If a Power Module Blocksize is connected to a Control Unit, the sampling times of all vector drives are set according to the rules for Power Modules Blocksize (only 250 µs or 500 µs possible).

13.10.3.4 Setting the pulse frequency

The sampling times for the following functions are set by selecting the appropriate values in p0112 for the closed-loop control configuration in μs and are copied to p0115[0...6] depending on the performance levels required:

- Current controller (p0115[0])
- Speed controller (p0115[1])
- Flux controller (p0115[2])
- Setpoint channel (p0115[3])
- Position controller (p0115[4])
- Positioner (p0115[5])
- Technology controller (p0115[6])

The performance levels range from xLow to xHigh. Details of how to set the sampling times are given in the SINAMICS S120/S150 List Manual.

Setting the pulse frequency using the commissioning tool in online operation

Enter the minimum pulse frequency in p0113. For isochronous operation (p0092 = 1), you can only set the parameter so that a resulting current controller cycle with an integer multiple of 125 μs is obtained. The required pulse frequency can be set after commissioning (p0009 = p0010 = 0) in p1800.

Table 13- 16 Pulse frequency for isochronous operation

Control type	p0115[0] Current controller cycle / μs	p0113 Pulse frequency / kHz
Servo control	250	2
	125	4
Vector control	500	1
	250	2

When commissioning is exited (p0009 = p0010 = 0), the effective pulse frequency (p1800) is appropriately pre-assigned, depending on p0113, and can be subsequently modified.

13.10.3.5 Setting sampling times

If sampling times are required which cannot be set using $p0112 > 1$, you can directly set the sampling times in expert mode using $p0115$.

If $p0115$ is changed online, then the values of higher indices are automatically adapted.

Note

Do not change the sampling times when the commissioning tool is in the offline mode, because in this case if there is an incorrect parameterization, the project download is canceled.

Making and checking settings

1. Activate in the expert list of the Control Unit the drive base configuration with $p0009 = 3$.
2. In the expert list of the drive object, activate the expert mode with $p0112 = 0$.
3. Specify the current controller cycle for the drive object as follows: $p0115[0] =$ current controller cycle.
For the current controller clock cycle, only use the values from "Table 13-18 Pulse frequencies and current controller cycles for servo control (Page 983)" and "Table 13-20 Pulse frequencies and current controller cycles for vector control (Page 984)".
4. Close in the expert list of the Control Unit the cycle setting with $p0009 = 0$.
A startup is then performed. The speed controller cycle and flux controller cycle are adapted automatically so that they remain an integer multiple of the current controller cycle.
5. Then check the maximum speed $p1082$, the set pulse frequency $p1800$ and start an automatic calculation of the controller data ($p0340 = 4$).

13.10.3.6 Overview of important parameters

Overview of important parameters (see SINAMICS S120/S150 List Manual)

- p0009 Device commissioning parameter filter
- p0092 Isochronous mode, pre-assignment/check
- p0097 Select drive object type
- r0110[0...2] Basic sampling times
- p0112 Sampling times pre-setting p0115
- p0113 Pulse frequency minimum selection
- r0114[0...9] Pulse frequency minimum recommended
- p0115[0...6] Sampling times for internal control loops
- r0116[0...1] Drive object cycle recommended
- p0118 Current controller computing dead time
- p0340[0...n] Automatic calculation of motor/control parameters
- p0799[0...2] CU inputs/outputs, sampling time
- p1082[0...n] Maximum velocity
- p1800[0...n] Pulse frequency setpoint
- p4099 Inputs/outputs sampling time
- r9780 SI monitoring cycle (Control Unit)
- r9880 SI monitoring cycle (Motor Module)
- r9976[0...7] System utilization

13.10.4 Rules for wiring with DRIVE-CLiQ

Rules apply for wiring components with DRIVE-CLiQ. A distinction is made between binding DRIVE-CLiQ rules, which must be unconditionally observed and recommended rules, which should then be maintained so that the topology, generated offline in the commissioning tool, no longer has to be changed.

The maximum number of DRIVE-CLiQ components and the possible wiring type depend on the following factors:

- The binding DRIVE-CLiQ wiring rules
- The number and type of activated drives and functions on the Control Unit in question
- The computing power of the Control Unit in question
- The set processing and communication cycles

Below you will find the binding wiring rules and some other recommendations as well as a few sample topologies for DRIVE-CLiQ wiring.

The components used in these examples can be removed, replaced with others or supplemented. If components are replaced by another type or additional components are added, then the SIZER configuring tool should be used to check this topology.

If the actual topology does not match the topology created offline using the commissioning tool, the offline topology must be changed accordingly before it is downloaded.

13.10.4.1 Binding DRIVE-CLiQ interconnection rules

The following generally binding DRIVE-CLiQ rules must be observed to ensure safe operation of the drive.

- Only one Control Unit is permitted in the role of DRIVE-CLiQ master in a DRIVE-CLiQ topology.
- A maximum of 14 DRIVE-CLiQ nodes can be connected to a Control Unit port on a DRIVE-CLiQ line.

Note

One Double Motor Module, one DMC20, one DME20, one TM54F and one CUA32 each correspond to two DRIVE-CLiQ nodes. This also applies to Double Motor Modules, at which just one drive is configured.

- Ring wiring or double wiring of components is not permitted.
- Drive topologies with DRIVE-CLiQ components that are not supported (by the type and the firmware version of the Control Unit) are not permitted.

- The sampling times (p0115[0] and p4099) of all components that are connected to a DRIVE-CLiQ line must be divisible by one another with an integer result, or all the sampling times set for the components must be an integer multiple of a common "base cycle".
 - Example 1: A Line Module with 250 μs and Motor Modules with 125 μs can be operated together on a DRIVE-CLiQ line ("base cycle": 125 μs)
 - Example 2: A Line Module with 250 μs and a Motor Module with 375 μs can be operated together on a DRIVE-CLiQ line ("base cycle": 125 μs)

If the current controller sampling time T_i at one drive object has to be changed in a sampling time that does not match the other drive objects in the DRIVE-CLiQ line, the following solutions are available:

- Insert the modified drive object into a separate DRIVE-CLiQ line. Note here that a total of 2 cycle levels are permissible on a Control Unit.
 - Modify the current controller sampling times and/or the sampling times of the inputs/outputs of the other drive objects similarly so they match the modified sampling time again.
- With the CU310-2 Control Unit the connection to the AC/AC Power Modules in chassis format is made via the DRIVE-CLiQ connection X100.

Rules and instructions for avoiding overloads

In general any overload must be avoided of a DRIVE-CLiQ line and the components connected to it through too many components with small sampling times. The following rules and instruction apply for this:

- A DRIVE-CLiQ line with components with a sampling time of $T_i = 31.25 \mu\text{s}$ may only be connected with components that are permitted for this sampling time. The following components are permitted:
 - Single Motor Modules in booksize format
 - Sensor Modules SMC20, SMI20, SMI24, SME20, SME25, SME120 and SME125
 - High-frequency damping modules (HF damping modules)
 - Additional DRIVE-CLiQ lines must be used for additional components.
- With current controller sampling times 31.25 μs and 62.5 μs the axes to the DRIVE-CLiQ connections must be distributed as follows:
 - DRIVE-CLiQ socket X100: Infeed, axes 2, 4, 6, ...
 - DRIVE-CLiQ socket X101: Axes 1, 3, 5, ...
- For a current controller cycle of 31.25 μs , a filter module should be directly connected to a DRIVE-CLiQ socket of the Control Unit.
- A maximum of 4 Motor Modules with Safety Extended Functions may be operated on one DRIVE-CLiQ line (for current controller cycle $T_{i\text{Reg}} = 125 \mu\text{s}$ on all axes). No further DRIVE-CLiQ components other than a Line Module and Sensor Modules may be connected to this DRIVE-CLiQ line.

Exception: For SINAMICS S120M, a maximum of 6 S120M with Safety Extended Functions can be operated on one DRIVE-CLiQ line.

The following applies for the CU Link and the CX32 and NX10/NX15 Control Units:

- In a topology with CU Link, the SINUMERIK NCU is DRIVE-CLiQ master for the NX and the SIMOTION D4xx is master for the CX32.
- The CX32 or NX10/NX15 Control Units are master for the subordinate components.
- The connection to the Control Unit is obtained from the PROFIBUS address of the CX/NX (10 → X100, 11 → X101, 12 → X102, 13 → X103, 14 → X104, 15 → X105).
- It is not permitted to combine SIMOTION Master Control Units and SINUMERIK Slave Control Units.
- It is not permitted to combine SINUMERIK Master Control Units and SIMOTION Slave Control Units.

13.10.4.2 Recommended interconnection rules

The following recommended rules should be observed for the DRIVE-CLiQ wiring:

General

- The following applies to all DRIVE-CLiQ components with the exception of the Control Unit: The DRIVE-CLiQ sockets Xx00 are DRIVE-CLiQ inputs (Uplink), the other DRIVE-CLiQ sockets are outputs (Downlink).
 - The DRIVE-CLiQ cable from the Control Unit should be connected to DRIVE-CLiQ socket X200 on the first booksize power unit or X400 on the first chassis power unit.
 - The DRIVE-CLiQ connections between the power units should each be connected from the DRIVE-CLiQ sockets X201 to X200 and/or X401 to X400 on the follow-on component.

Line Modules

- An individual Line Module should be connected directly to the Control Unit (recommended DRIVE-CLiQ socket: X100).
 - Several Line Modules should be connected in series.

Motor Modules

- No more than 6 Motor Modules should be connected to a DRIVE-CLiQ line on the Control Unit (including with vector, V/f control).
- Motor Modules should be connected directly to the Control Unit in vector control.
 - If the DRIVE-CLiQ socket X100 is already assigned to a Line Module, the DRIVE-CLiQ socket X101 should be used.
 - Several Motor Modules should be connected in a line.
 - If there is already a Line Module present at X100, the Motor Module should be connected in line to socket X201 of the Line Module.
 - Several Motor Modules should be connected in a line.

- In servo control Motor Modules should be connected to a DRIVE-CLiQ line together with the Line Module.
 - Several Motor Modules should be connected in a line.
 - If there is already a Line Module present, the first Motor Module should be connected in line to socket X201 of the Line Module.
 - If there is no Line Module present, the first Motor Module should be connected directly to the Control Unit (recommended DRIVE-CLiQ socket: X100).
- If the Motor Modules need to be distributed across two DRIVE-CLiQ lines (e.g. on account of the predetermined current controller sampling times), the next higher DRIVE-CLiQ socket on the Control Unit should be used.
Example, vector control in the chassis format:
 - Active Line Module current controller cycle 400 μ s: X100
 - Motor Module current controller cycle 250 μ s: X101
 - Motor Module current controller cycle 400 μ s: X102
- Only one end node should be connected to free DRIVE-CLiQ sockets within a DRIVE-CLiQ line (e.g. Motor Modules wired in a line), for example, one Sensor Module or one Terminal Module, without routing to additional components.
- For mixed operation of the servo control and vector V/f control operating modes, separate DRIVE-CLiQ lines should be used for the Motor Modules.
- A Power Module with the CUA31/CUA32 should be connected to the middle or end of the DRIVE-CLiQ line.

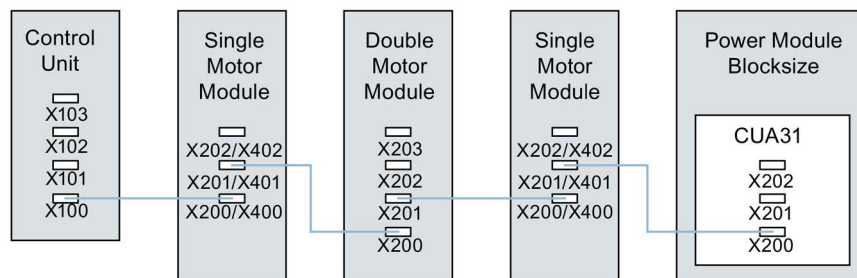

Figure 13-17 DRIVE-CLiQ line example

Encoder, Sensor Modules

- The motor encoder or Sensor Module should be connected to the associated Motor Module.
Connecting the motor encoder via DRIVE-CLiQ:
 - Single Motor Module Booksize to terminal X202
 - Double Motor Module Booksize motor X1 to terminal X202 and motor X2 to terminal X203
 - Single Motor Module chassis to terminal X402
 - Power Module blocksize with CUA31: Encoder to terminal X202
 - Power Module blocksize with CU310-2: Encoder to terminal X100 or to terminal X501 of a Terminal Module
 - Power Module chassis to terminal X402
- If possible, Sensor Modules of direct measuring systems should not be connected to the DRIVE-CLiQ line of Motor Modules, but rather to free DRIVE-CLiQ sockets of the Control Unit.

Note

This restriction does not apply to star-type connections for the Motor Modules.

Voltage Sensing Modules

- The Voltage Sensing Module (VSM) should be connected to the DRIVE-CLiQ socket X202 (booksize format) or X402 (chassis format) of the associated Line Module/Motor Module.
 - If the DRIVE-CLiQ socket X202/X402 is not available, a free DRIVE-CLiQ socket on the Line Module/Motor Module should be selected.

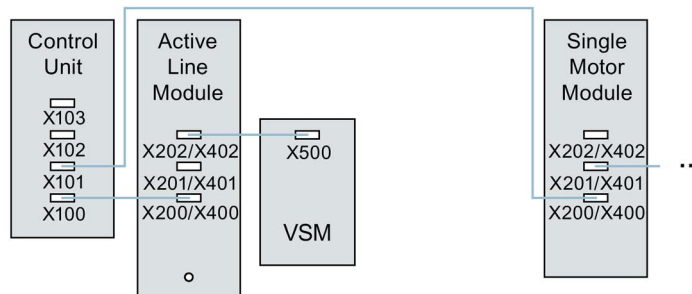

Figure 13-18 Example of a topology with VSM for booksize and chassis components

Terminal Modules

- Terminal Modules should be connected to DRIVE-CLiQ socket X103 of the Control Unit in series.
- The TM54F should not be operated together on the same DRIVE-CLiQ line as Line Modules or Motor Modules.
- If possible, Terminal Modules should not be connected to the DRIVE-CLiQ line of Motor Modules, but rather to free DRIVE-CLiQ sockets of the Control Unit.

Note

This restriction does not apply to star-type connections for the Motor Modules.

13.10.4.3 Rules for automatic configuration

With "Automatic Configuration" (Auto commissioning) the Control Unit software creates drive objects for the connected Line Modules, Motor Modules and Terminal Modules. For the Motor Modules the control mode is set via parameter p0097.

In addition to this the following DRIVE-CLiQ wiring topologies support automatic assignment of components to the drive objects.

- An encoder that is connected directly to a Motor Module or via a Sensor Module, is assigned to this drive object as motor encoder (encoder 1).
- If a second encoder is connected to a Motor Module in addition to the motor encoder, it is assigned to the drive as encoder 2. The encoder connected to terminal X202 or X402 is then the motor encoder (encoder 1).
- If a TM120 or TM150 is connected to the Motor Module, the temperature channels of the TM are connected with the motor temperature monitoring of the drive. In this case, the motor encoder may be connected to the TM120 or TM150.
- If a Voltage Sensing Module (VSM) is connected to a Line Module then it is assigned to the infeed drive object.

Recommended connection:

- Booksize to terminal X202
- Chassis to terminal X402
- If a Voltage Sensing Module (VSM) is connected to a Motor Module then it is assigned to the drive object.

Note

If two VSMs are connected to the Motor Module, the first (p0151[0]) is assigned to the line voltage measurement (see p3801) and the second is assigned to the motor voltage measurement (see p1200).

13.10.4.4 Changing the offline topology in the STARTER commissioning tool

The device topology can be changed in the STARTER commissioning tool by shifting the components in the topology tree.

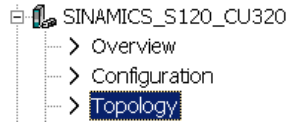

Example: Changing the DRIVE-CLiQ topology

1. Select the DRIVE-CLiQ component.

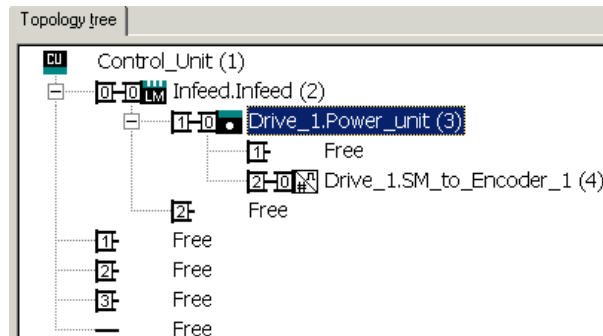

2. While holding down the mouse button, drag the component to the required DRIVE-CLiQ interface and release the mouse button.

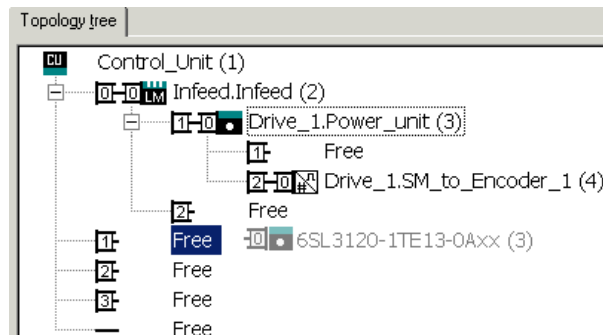

You have changed the topology in the STARTER commissioning tool.

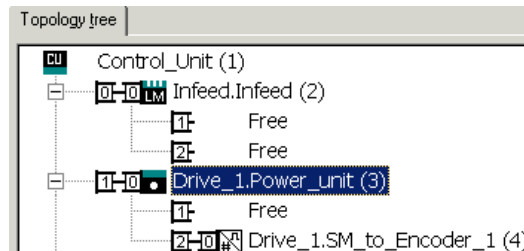

13.10.4.5 Modular machine concept: Offline correction of the reference topology

The topology is based on a modular machine concept. The machine concept is created offline in the STARTER commissioning tool in the maximum version as reference topology.

The maximum version is the maximum expansion of a particular machine type. In the maximum version, all the machine components that can be used are pre-configured in the reference topology.

Deactivating components / handling non-existent components

In a lower expansion stage of the machine, you must mark drive objects and encoders that are not used in the STARTER topology. To do this, for the corresponding drive objects and encoder, set parameter p0105 or p0145 = 2 (deactivate component and does not exist). Components set to the value "2" in a project generated offline must never be inserted in the actual topology at all.

If a component fails, the sub-topology can also be used to allow a machine to continue to operate until the spare part is available. In this case, however, no BICO source must be interconnected from this drive object to other drive objects.

Example of a sub-topology

The starting point is a machine created offline in the STARTER commissioning tool. "Drive 1" was not implemented for this machine.

1. You can remove drive object "Drive 1" "offline" from the reference topology using p0105 = 2.
2. Change over the DRIVE-CLiQ cable from the Control Unit directly to "Drive 2".
3. Transfer the project with "Download to drive unit".
4. Then execute a "Copy RAM to ROM".

Figure 13-19 Example of a sub-topology

Note

Incorrect SI status display

If a drive in a Safety Integrated drive line-up is deactivated using p0105, then r9774 is not correctly output. The signals of a deactivated drive are no longer updated.

Activating/deactivating components

Drive objects can be activated/deactivated using parameter p0105 and encoders with p0145[0...n] in the Expert list in the same way. If a component is not required at certain times, then for the component, change parameter p0105 or p0145 from "1" to "0". The deactivated components remain inserted, however, they are deactivated. Errors are not displayed from deactivated components.

Overview of important parameters (see SINAMICS S120/S150 List Manual)

- p0105 Activating/deactivating drive object
- r0106 Drive object active/inactive
- p0125[0...n] Activate/deactivate power unit component
- r0126[0...n] Power unit components active/inactive
- p0145[0...n] Enable/disable sensor interface
- r0146[0...n] Sensor interface active/inactive
- p9495 BICO behavior for deactivated drive objects
- p9496 BICO behavior when activating drive objects
- p9498[0...29] BICO BI/CI parameters to de-activated drive objects
- p9499[0...29] BICO BO/CO parameters to de-activated drive objects
- r9774.0...31 CO/BO: SI Status (group STO)

13.10.5 Notes on the number of controllable drives

13.10.5.1 Number of drives depending on the control mode and cycle times

The number of axes that can be operated with a Control Unit depends on the cycle times and the control mode. The number of usable axes and the associated clock cycle times for each control type are listed below. The other available remaining computation times are available for options (e.g. DCC).

Cycle times for servo control and HLA

The following table lists the number of axes that can be operated with a Control Unit in servo control and HLA. The number of axes is also dependent on the cycle times of the controller:

Table 13- 17 Sampling time setting for servo control

Cycle times [µs]		Number		Motor/dir. measuring systems	TM ¹⁾ /TB
Current controller	Speed controller	Axes	Infeed		
125	125	6	1 [250 µs]	6 / 6	3 [2000 µs]
62.5	62.5	3	1 [250 µs]	3 / 3	3 [2000 µs]
31.25 ²⁾	31.25 ²⁾	1	1 [250 µs]	1 / 1	3 [2000 µs]

- 1) Valid for TM31 or TM15IO; restrictions are possible for TM54F, TM41, TM15, TM17, TM120, TM150 depending on the set sampling time.
- 2) In the cycle level 31.25 µs, you can also create the following objects:
 Sensor Module External (SME) and SMC20 that support the current firmware and hardware. These can be recognized from the Article end number ... 3.
 No additional axis can be operated in this cycle level.

Adjustable pulse frequencies and current controller cycles for servo control

The pulse frequencies that can be set depending on the selected current controller cycle are shown in r0114. Because of the integrating current measurement, pulse frequencies that are a multiple of half the current controller sampling frequency should be preferred. Otherwise, the current is not measured synchronous to the pulse frequency and a fluctuating actual current value results. This causes disturbance in the control circuits and higher losses in the motor (such as pulse frequency 5.333 kHz and current controller cycle 62.5 μ s).

The recommended settings are marked with **XX** in the Table; all other possible settings are marked with X.

Table 13- 18 Pulse frequencies and current controller cycles for servo control

Pulse frequency [kHz]	Current controller cycle [μ s]										
	250.0	187.5	150.0	125.0	100.0	93.75	75.0	62.5	50.0	37.5	31.25
16.0	X	-	-	X	-	-	-	X	-	-	XX
13.333	-	-	X	-	-	-	X	-	-	XX	-
12.0	X	-	-	-	-	-	-	-	-	-	-
10.666	-	X	-	-	-	X	-	-	-	-	X
10.0	-	-	-	-	X	-	-	-	XX	-	-
8.888	-	-	-	-	-	-	-	-	-	X	-
8.0	X	-	-	X	-	-	-	XX	-	-	X
6.666	-	-	X	-	-	-	XX	-	X	X	-
6.4	-	-	-	-	-	-	-	-	-	-	X
5.333	-	X	-	-	-	XX	-	X	-	X	-
5.0	-	-	-	-	XX	-	-	-	X	-	-
4.444	-	-	-	-	-	-	X	-	-	-	-
4.0	X	-	-	XX	-	-	-	X	-	-	-
3.555	-	-	-	-	-	X	-	-	-	-	-
3.333	-	-	XX	-	X	-	X	-	-	-	-
3.2	-	-	-	-	-	-	-	X	-	-	-
2.666	-	XX	-	X	-	-	-	-	-	-	-
2.5	-	-	-	-	X	-	-	-	-	-	-
2.222	-	-	X	-	-	-	-	-	-	-	-
2.133	-	-	-	-	-	X	-	-	-	-	-
2.0	XX	-	-	X	X	-	-	-	-	-	-
1.777	-	X	-	-	-	-	-	-	-	-	-
1.666	-	-	X	-	-	-	-	-	-	-	-
1.6	-	-	-	X	-	-	-	-	-	-	-
1.333	-	X	X	-	-	-	-	-	-	-	-

Note

Clock cycle mix

Detailed information about the clock cycle mix for servo control is provided in Section Cycle mix for servo control and vector control (Page 988).

Cycle times for vector control

This following table lists the number of axes that can be operated with a Control Unit in the vector control mode. The number of axes is also dependent on the cycle times of the controller:

Table 13- 19 Sampling time setting for vector control

Cycle times [µs]		Number		Motor/dir. measuring systems	TM ¹ /TB
Current controller	Speed controller	Axes	Infeed ²⁾		
500 µs	2000 µs	6	1 [250 µs]	6 / 6	3 [2000 µs]
400 ³⁾ µs	1600 µs	5	1 [250 µs]	5/5	3 [2000 µs]
250 µs	1000 µs	3	1 [250 µs]	3 / 3	3 [2000 µs]

- 1) Valid for TM31 or TM15IO; restrictions are possible for TM54F, TM41, TM15, TM17, TM120, TM150 depending on the set sampling time.
- 2) For power units in chassis format, the infeed cycle depends on the power rating of the module and can be 400 µs, 375 µs or 250 µs.
- 3) This setting results in lower remaining computation times.

Adjustable pulse frequencies and current controller cycles for vector control

The pulse frequencies that can be set depending on the selected current controller cycle are shown in r0114.

This means that maximum 2 cycle levels can be mixed.

Note

Clock cycle mix

Detailed information about the clock cycle mix for servo control is provided in Section Cycle mix for servo control and vector control (Page 988).

Table 13- 20 Pulse frequencies and current controller cycles for vector control

Pulse frequency [kHz]	Current controller cycle [µs]											
	500.0	375.0	312.5	250.0	218.75	200.0	187.5	175.0	156.25	150.0	137.5	125.0
16.0	X	X	X	X	-	-	X	-	-	-	-	X
15.0	-	-	-	-	-	X	-	-	-	-	-	-
14.545	-	-	-	-	-	-	-	-	-	-	X	-
14.0	X	-	-	-	-	-	-	-	-	-	-	-
13.714	-	-	-	-	X	-	-	-	-	-	-	-
13.333	-	X	-	-	-	-	-	-	-	X	-	-
12.8	-	-	X	-	-	-	-	-	X	-	-	-
12.0	X	-	-	X	-	-	-	-	-	-	-	-
11.428	-	-	-	-	-	-	-	X	-	-	-	-

Pulse frequency [kHz]	Current controller cycle [μ s]											
	500.0	375.0	312.5	250.0	218.75	200.0	187.5	175.0	156.25	150.0	137.5	125.0
10.666	-	X	-	-	-	-	X	-	-	-	-	-
10.0	X	-	-	-	-	X	-	-	-	-	-	-
9.6	-	-	X	-	-	-	-	-	-	-	-	-
9.142	-	-	-	-	X	-	-	-	-	-	-	-
8.0	X	X	-	X	-	-	-	-	-	-	-	X
7.272	-	-	-	-	-	-	-	-	-	-	X	-
6.666	-	-	-	-	-	-	-	-	-	X	-	-
6.4	-	-	X	-	-	-	-	-	X	-	-	-
6.0	X	-	-	-	-	-	-	-	-	-	-	-
5.714	-	-	-	-	-	-	-	X	-	-	-	-
5.333	-	X	-	-	-	-	X	-	-	-	-	-
5.0	-	-	-	-	-	X	-	-	-	-	-	-
4.571	-	-	-	-	X	-	-	-	-	-	-	-
4.0	X	-	-	X	-	-	-	-	-	-	-	X
3.636	-	-	-	-	-	-	-	-	-	-	X	-
3.333	-	-	-	-	-	-	-	-	-	X	-	-
3.2	-	-	X	-	-	-	-	-	X	-	-	-
2.857	-	-	-	-	-	-	-	X	-	-	-	-
2.666	-	X	-	-	-	-	X	-	-	-	-	-
2.5	-	-	-	-	-	X	-	-	-	-	-	-
2.285	-	-	-	-	X	-	-	-	-	-	-	-
2.0	X	-	-	X	-	-	-	-	-	-	-	-
1.6	-	-	X	-	-	-	-	-	-	-	-	-
1.333	-	X	-	-	-	-	-	-	-	-	-	-
1.0	X	-	-	-	-	-	-	-	-	-	-	-

Note**Restriction for the chassis format**

If edge modulation and wobbling are activated simultaneously with $p1802 \geq 7$ and $p1810.2 = 1$ respectively, the quantity structure for vector control is halved. Then a maximum of 3 axes at a current control cycle of 500 μ s, 2 axes at 400 μ s or 1 axis at 250 μ s are permitted.

Cycle times for V/f control

The following table lists the number of axes that can be operated with a Control Unit in the V/f control mode. The number of axes is dependent on the current controller clock cycle:

Table 13- 21 Sampling time setting for V/f control

Cycle times [μs]		Number		Motor/dir. measuring systems	TM/TB
Current controller	Speed controller	Drives	Infeed		
500	2000	12	1 [250 μs]	- / -	3 [2000 μs]

Mixed operation of servo control and V/f open-loop control

In mixed operation with servo control and U/f control, one axis in servo control at 125 μs uses exactly as much computing power as 2 axes in U/f control at 500 μs. In conjunction with servo control, a maximum of 11 axes are permitted (1 servo control plus 10 vector control V/f).

Table 13- 22 Number of axes for mixed servo control operation

Number of axes in servo control				Number of axes in V/f control	
6	125 μs	3	62.5 μs	0	-
5	125 μs	-	-	2	500 μs
4	125 μs	2	62.5 μs	4	500 μs
3	125 μs	-	-	6	500 μs
2	125 μs	1	62.5 μs	8	500 μs
1	125 μs	-	-	10	500 μs
0	-	0	-	12	500 μs

Mixed operation of vector control and V/f open-loop control

In mixed operation with vector control and V/f control, one axis in vector control at 250 μs uses exactly as much computing power as two axes in V/f control at 500 μs. In conjunction with vector control, a maximum of 11 axes are permitted (1 vector control plus 10 V/f control).

Table 13- 23 Number of axes for mixed vector control operation

Number of axes in vector control				Number of axes in V/f control	
6	500 μs	3	250 μs	0	-
5	500 μs	-	-	2	500 μs
4	500 μs	2	250 μs	4	500 μs
3	500 μs	-	-	6	500 μs
2	500 μs	1	250 μs	8	500 μs
1	500 μs	-	-	10	500 μs
0	-	0	-	12	500 μs

Cycle times of the CU310-2 in the servo control mode

Table 13- 24 Sampling time setting for servo control

Cycle times [μ s]		Number		Via DQ ²⁾	Snapped-on	TM ¹⁾ /TB
Current controller	Speed controller	Axes	Infeed	Motor Module	Power Module	
125	125	1	-	-	1	3 [2000 μ s]
62.5	62.5	1	-	-	1	3 [2000 μ s]

1) Valid for TM15, TM17 or TM41; for TM54F, TM31, TM120, TM150 - restrictions are possible dependent on the set sampling time.

2) DQ = DRIVE-CLiQ

If the 310-2 Control Unit is snapped on to a PM340 or a PM240-2 FS A-C, a minimum current controller clock cycle of 62.5 μ s is possible. For PM240-2 FS D-F the minimum current controller clock cycle is 125 μ s.

Using DCC

The available remaining computation time can be used for DCC. In this case, the following supplementary conditions apply:

- For a 2 ms time slice, a max. of 75 DCC blocks can be configured for each servo control axis with 125 μ s that can be omitted/eliminated (\pm 2 V/f axes with 500 μ s).
- 50 DCC blocks for 2 ms time slice correspond to 1.5 V/f axes with 500 μ s.

Detailed information about handling and using DCC standard blocks is provided in the "SINAMICS/SIMOTION Editor Description DCC" manual.

Using EPOS

The following table lists the number of axes that can be operated with a SINAMICS S120 when using a "basic positioner" (EPOS) function module. The number of axes is dependent on the current controller clock cycle.

Table 13- 25 Sampling times when using EPOS

Cycle times [μ s]		Cycle times [ms]		Number	
Current controller	Speed controller	Position controller	Positioner	Axes	Infeed
250	250	2	8	6	1 [250 μ s]
250	250	1	4	5	1 [250 μ s]
125	125	1	4	4	1 [250 μ s]

The CPU processing time required for the function module EPOS (with 1 ms position controller/4 ms positioner) corresponds to the same CPU processing time of 0.5 V/f axes with 500 μ s.

Use of SINAMICS web server

The available computation time can be used for SINAMICS web server. The following boundary condition applies here:

- The utilization of the system (r9976) must be less than 90%!
- A maximum of 5 users can access data on the same drive via the SINAMICS web server.

Using CUA31/CUA32

Information on using the Control Unit Adapter CUA31 or CUA32:

- CUA31/32 is the first component in the CUA31/32 topology: 5 axes
- CUA31/32 is **not** the first component in the CUA31/32 topology: 6 axes
- For a current controller cycle of 62.5 μ s, only one axis is possible with one CUA31/32.

13.10.5.2 Cycle mix for servo control and vector control

Supplementary conditions

The rules for setting the sampling time (see Chapter Rules when setting the sampling times (Page 963)) and the rules on isochronous mode (see Chapter Rules for isochronous mode (Page 966)) apply.

These rules mean that the smallest common multiple of the current controller cycles of all axes operated on the isochronous PROFIBUS and 125 μ s is used to set T_i , T_o and T_{dp} .

Current controller cycles for cycle mix

Consequently the smallest common multiple of the current and speed controller cycles of all axes operated on the isochronous PROFIBUS is used to set the base cycle for T_i , T_o and T_{dp} . For a cycle mix, a compromise must be sought between the base cycle to set T_i , T_o and T_{dp} , and the required pulse frequency.

Table 13- 26 Examples of cycle mixes for servo control

Cycle mix: Current controller cycles [μ s]		Base cycle for T_i , T_o [μ s]	Base cycle for T_{dp} , T_{mapc} [μ s]
250.00	+125.00	250	250
187.50	+125.00	375	750
150.00	+125.00	750	750
125.00	+125.00	125	250
100.00	+125.00	500	500
93.75	+125.00	375	750
75.00	+125.00	375	750
62.50	+125.00	125	250
50.00	+125.00	250	250
37.50	+125.00	750	750
31.25	+125.00	125	250

Base cycles for the isochronous PROFIBUS for a cycle mix with 125 μ s

Table 13- 27 Examples for cycle mixes for vector control

Cycle mix: Current controller cycles [μ s]		Base cycle for T_i , T_o [μ s]	Base cycle for T_{dp} [μ s]	Base cycle for T_{mapc} [μ s]
500.00	+250.00	500	500	2000
375.00	+250.00	750	750	3000
312.50	+250.00	1250	1250	5000
250.00	+250.00	250	250	1000
218.75	+250.00	1750	1750	7000
200.00	+250.00	1000	1000	4000
187.50	+250.00	750	750	3000
175.00	+250.00	1750	1750	7000
156.25	+250.00	1250	1250	5000
150.00	+250.00	750	750	3000
137.50	+250.00	2750	2750	11000
125.00	+250.00	250	250	1000

Base cycles for the isochronous PROFIBUS for a cycle mix with 250 μ s

Note

The speed controller cycle is assigned automatically when the current controller cycle is set:

- Servo control: Speed controller cycle = current controller cycle
- Vector control: Speed controller cycle = current controller cycle x 4

The preassignment of the speed controller cycle can be changed to influence T_{mapc} . For example, the current controller cycle can be increased from 800 μs to 1000 μs so that T_{mapc} can be set to be a multiple of 1000 μs .

Asynchronous node on the isochronous PROFIBUS

For cycle mix, lengthened base cycles with the following effects often result on the isochronous PROFIBUS:

- Because the isochronous PROFIBUS can no longer be operated with the default setting, adaptations must be made to the hardware configuration.
- The increased setting values for T_i , T_o and T_{dp} have disadvantageous effects on the dynamics of the position control loop.

Despite a cycle mix, the parameter p2049 can be used to operate the axis with the different current controller cycle asynchronously on the isochronous PROFIBUS. This allows the default setting of the hardware configuration to be retained.

This, however, causes the advantages of the isochronous operation for the asynchronous axis to be lost:

- The setpoints act at times that differ from T_o , i.e. an interpolating position-controlled operation with other axes is not possible.
- The actual values are read at times that differ from T_i , i.e. the actual values must not be used to control other axes.

A critical application would be, for example, a spindle that cuts a thread with the programmed thread pitch together with a position-controlled Z-axis by the controller adjusting the plunging depth of the Z-axis depending on the spindle position.

13.11 Supported sample topologies

13.11.1 Topology example: Drives in vector control

Example 1

A drive line-up with three Motor Modules in chassis format with identical pulse frequencies or three Motor Modules in booksize format in vector control mode.

The Motor Modules chassis format with identical pulse frequencies or the Motor Modules booksize format in vector control mode can be connected to 1 DRIVE-CLiQ interface on the Control Unit.

In the following diagram, three Motor Modules are connected to the DRIVE-CLiQ socket X101.

Note

The offline topology automatically generated in the STARTER commissioning tool must be manually modified, if this topology was wired.

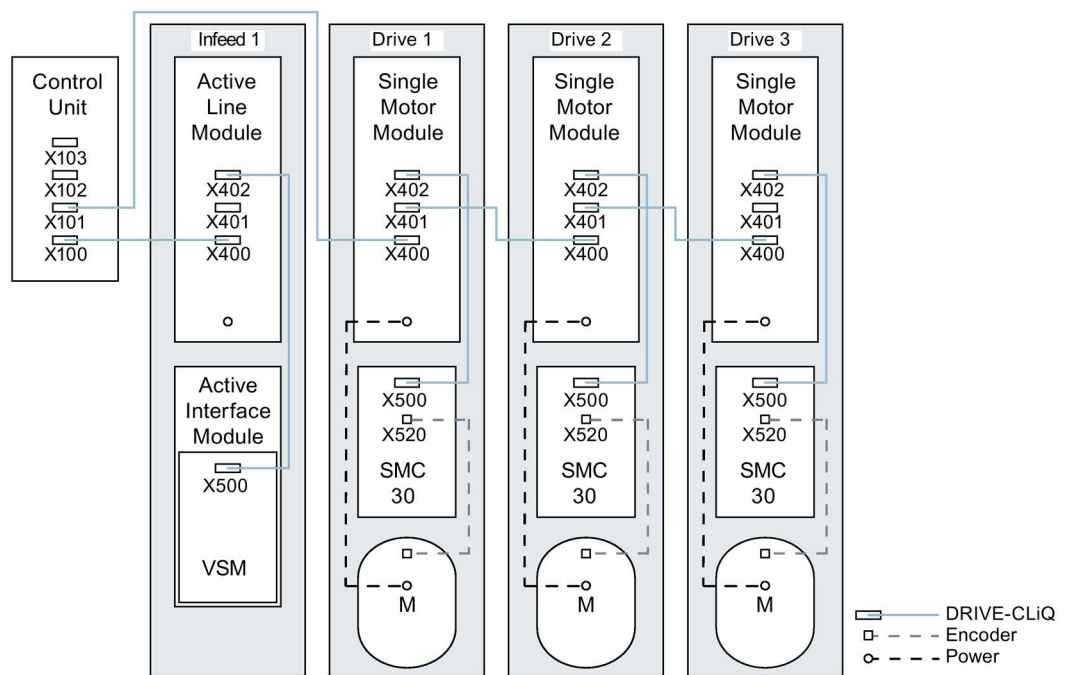

Figure 13-20 Drive line-up (chassis) with identical pulse frequencies

Drive line-up comprising four Motor Modules in the chassis format with different pulse frequencies

It is advantageous to connect Motor Modules with different pulse frequencies to different DRIVE-CLiQ sockets of the Control Unit. They may also be connected at the same DRIVE-CLiQ line.

In the following diagram, two Motor Modules (400 V, output ≤ 250 kW, pulse frequency 2 kHz) are connected to interface X101 and two Motor Modules (400 V, output > 250 kW, pulse frequency 1.25 kHz) are connected to interface X102.

Note

The offline topology automatically generated in the STARTER commissioning tool must be manually modified, if this topology was wired.

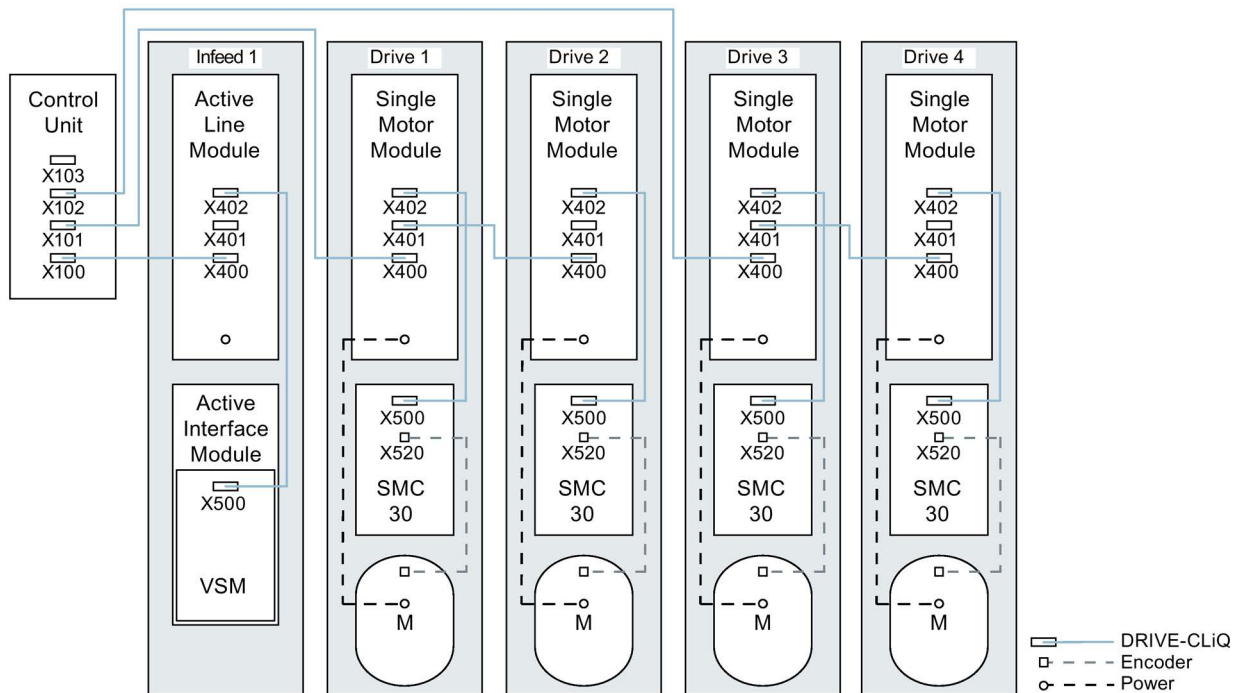

Figure 13-21 Drive line-up in chassis format with different pulse frequencies

13.11.2 Topology example: Parallel Motor Modules in vector control

Drive line-up with two parallel-connected Line Modules and Motor Modules in the chassis format of the same type

Parallel-connected Line Modules in the chassis format and Motor Modules in the chassis format of the same type can be connected to a DRIVE-CLiQ socket of the Control Unit.

In the following diagram, two Active Line Modules and two Motor Modules are connected to the X100 or X101 socket.

You can find additional notes in Chapter "Parallel connection of power units" in the SINAMICS S120 Function Manual.

Note

The offline topology automatically generated in the STARTER commissioning tool must be manually modified, if this topology was wired.

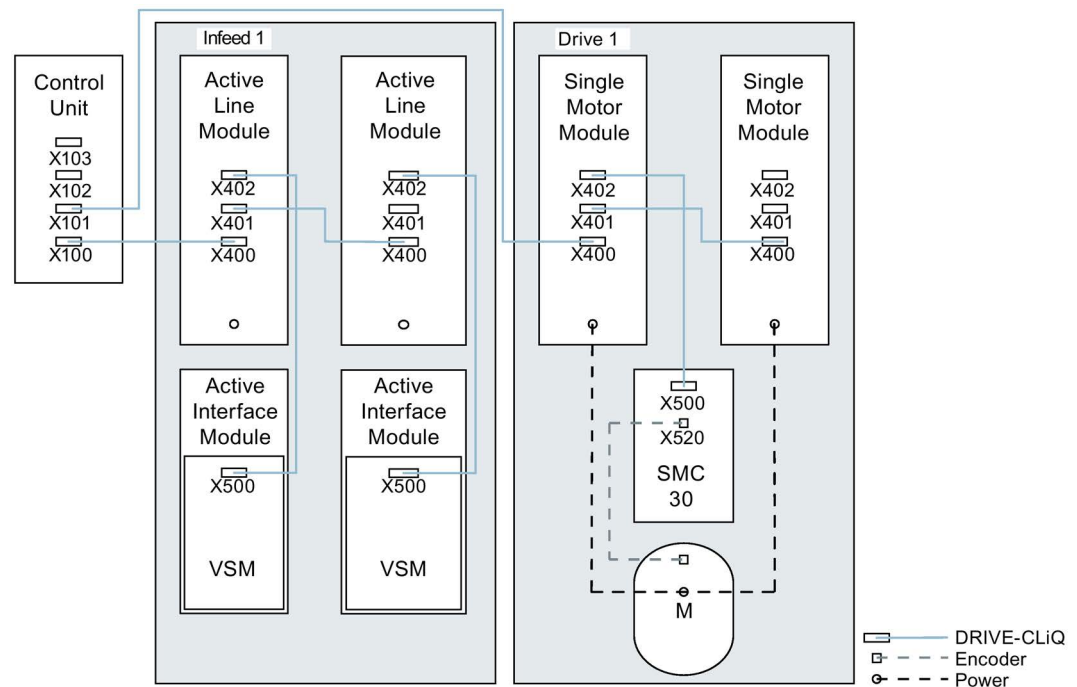

Figure 13-22 Drive line-up with parallel-connected power units in the chassis format

13.11.3 Topology example: Power Modules

Blocksize

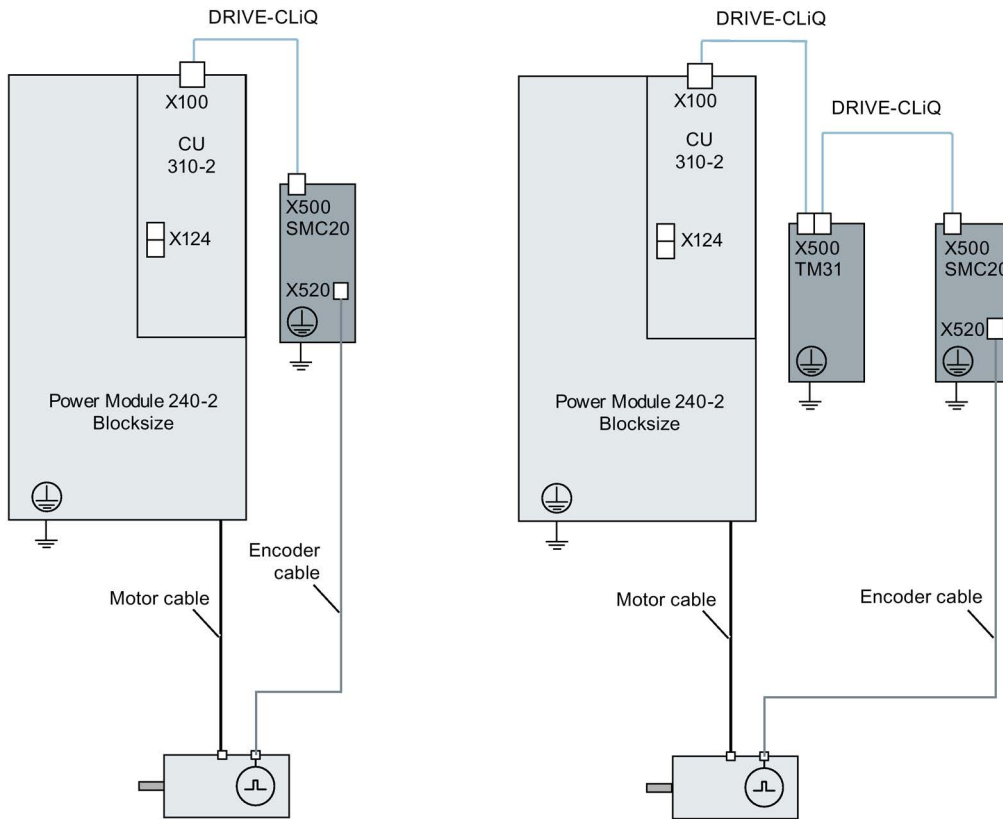

Figure 13-23 Drive line-ups with Power Modules blocksize

Chassis

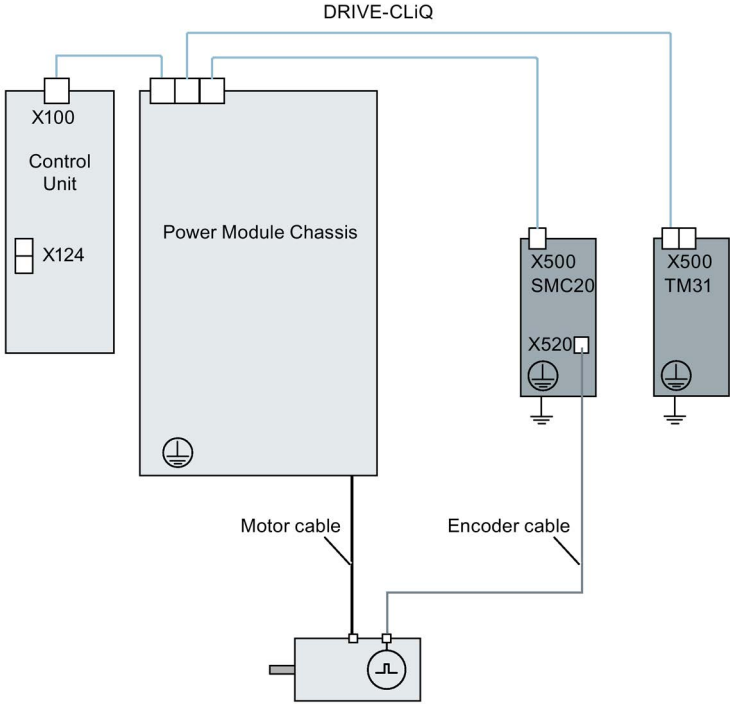

Figure 13-24 Drive line-up of a Power Module chassis

13.11.4 Example topologies: Drives in servo control

13.11.4.1 Example: Sampling time 125 µs

The following diagram shows the maximum number of controllable servo drives and extra components. The sampling times of individual system components are:

- Active Line Module: p0115[0] = 250 µs
- Motor Modules: p0115[0] = 125 µs
- Terminal Module/Terminal Board p4099 = 1 ms

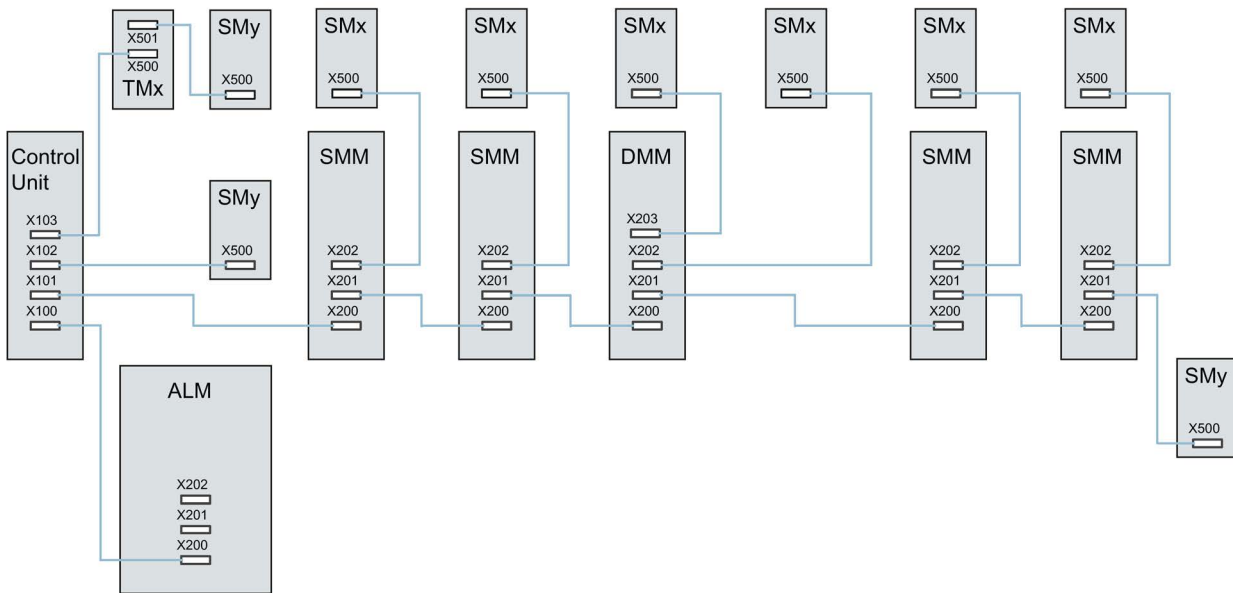

Figure 13-25 Topology example of a SERVO drive line-up

Legend for the topology example:
 ALM = Active Line Module
 SMM = Single Motor Module
 DMM = Double Motor Module
 SMx = Motor encoder
 SMY = Direct measuring system
 TMx = TM31, TM15DI/DO, TB30

13.11.4.2 Examples: Sampling time 62.5 μ s and 31.25 μ s

Examples, CU320-2 with 62.5 μ s sampling time:

- Topology 1: 1 x ALM (250 μ s) + 2 x servo (62.5 μ s) + 2 x servo (125 μ s) + 3 x TM15 Base (p4099[0] = 2000 μ s) + TM54F + 4 x Safety Integrated Extended Functions with encoder SI Motion monitoring clock cycle (p9500) = 12 ms + SI Motion actual value sensing clock cycle (p9511) = 4 ms + 4 x direct measuring systems.
- Topology 2: 1 x ALM (250 μ s) + 2 x servo (62.5 μ s) + 2 x V/f (500 μ s) + 3 x TM15 Base (p4099[0] = 2000 μ s) + 2 x Safety Integrated Extended Functions with encoder SI Motion monitoring clock cycle (p9500) = 12 ms + SI Motion actual value sensing clock cycle (p9511) = 4 ms + 2 x Safety Integrated Extended Functions sensorless + 2 x direct measuring systems.
- Topology 3: 1 x servo (62.5 μ s) + 4 x V/f is not possible in connection with Safety Integrated.

Example, CU320-2 with 31.25 μ s sampling time:

- Topology 1: 1 ALM (250 μ s) on a line, 1 x servo (31.25 μ s) on a line, 3 x TM15 Base (p4099[0] = 2000 μ s) on a line and in series.
- Topology 2: 1 ALM (250 μ s) on a line, 1 x servo (31.25 μ s) on a line, 1 direct measuring system on a line.

13.11.5 Topology example: Drives in U/f control (vector control)

The following diagram shows the maximum number of controllable vector V/f drives with additional components. The sampling times of individual system components are:

- Active Line Module: p0115[0] = 250 μs
- Motor Modules: p0115[0] = 500 μs
- Terminal Module/Terminal Board p4099 = 2 ms

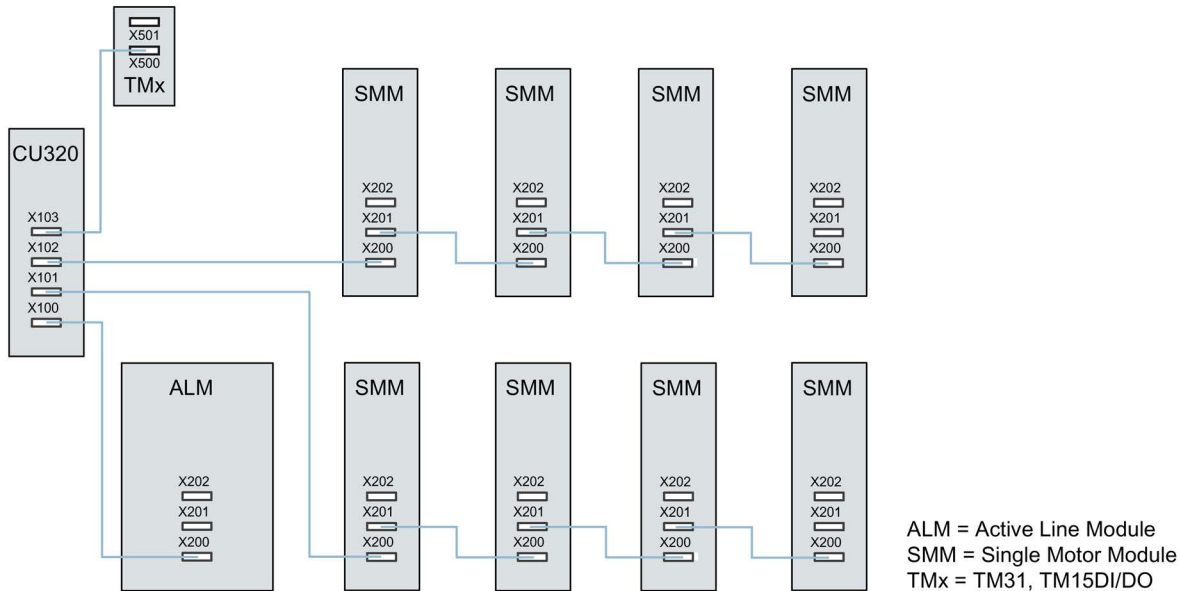

Figure 13-26 Topology example of a vector drive line-up in U/f control

13.12 DRIVE-CLiQ diagnostics

Using the DRIVE-CLiQ diagnostics, you can check the connections and cables of DRIVE-CLiQ connections. For data transfer errors, to localize the faulted connection, the error counter in the involved blocks can be evaluated.

In addition to the error counter showing all errors, detailed diagnostics can be carried out for the individual connections. For selected connections, the number of errors is determined for a time interval that can be specified and made traceable using a parameter. As a result of the interconnectability, you can record when data transfer errors occur and correlate them with other events in the drive.

Overview of important parameters (see SINAMICS S120/S150 List Manual)

- r9936[0...199] DRIVE-CLiQ diagnostics, error counter connection
- p9937 DRIVE-CLiQ diagnostics configuration
- p9938 DRIVE-CLiQ detailed diagnostics configuration
- p9939 DRIVE-CLiQ detailed diagnostics time interval
- p9942 DRIVE-CLiQ detailed diagnostics individual connection selection
- r9943 DRIVE-CLiQ detailed diagnostics individual connection error counter

13.13 Emergency operating mode for DRIVE-CLiQ components

In order to protect the drive system against excessive voltage when the Control Unit or DRIVE-CLiQ communication fails (e.g. while a spindle is rotating), an autonomous emergency operating mode (independent operation) is integrated in DRIVE-CLiQ components for the following functions:

- Chopper mode (for Basic Line Module 20 kW / 40 kW in combination with an external braking resistor).
- Integrated voltage protection for machines with a high kinetic energy (armature short-circuit controlled by the Motor Modules on the basis of the DC link voltage).

Features

- Resumption and resynchronization of DRIVE-CLiQ communication in emergency mode when necessary (only if clock cycle conditions have not changed) and without POWER ON.
- Changeover from emergency operation to normal operation without POWER ON of the component.
- Defined response with factory setting / project download.

Note

Autonomous (emergency) operation is possible only for Motor Modules and Basic Line Modules with article numbers that end with the code ..3, e.g. 6SL3130-6TE21-6AA3.

Principle of operation

Two task profiles are obtained for autonomous operation:

- Recognize that a component is getting into a critical state and the protective function must be maintained.
- Restore communication with the higher-level controller.

In order to maintain the protective function, the time-slice system must remain active. The logged-on time-slice system remains active until the protective functions signal that a safe state has been reached and the time slices can therefore be deactivated. When restarting the communication, if the DRIVE-CLiQ master signals that no bus timing changes have been made with respect to the old parameterization, then synchronization is possible. The time-slice system remains the same as before.

Note

All algorithms for autonomous operation are executed as a background process for the component. They thus have no influence on the computer resources utilized cyclically by the component.

Communication restart includes a topology detection during emergency operation.

Note

When the component is running in emergency mode, it cannot be deactivated.

Preparation for autonomous time-slice operation

The application signals (basic system DRIVE-CLiQ slave components) preparation for autonomous time-slice operation. This occurs, for example, when the "armature short-circuit" protective function is active or in chopper operation.

Changeover from normal to autonomous operation

The application activates autonomous time-slice operation. Changeover takes place instantaneously.

Changeover from autonomous to normal operation

It is always possible to change over into normal operation without a POWER ON.

Resumption of DRIVE-CLiQ communication when autonomous mode is active

A distinction must be made between the following two operating states:

- The DRIVE-CLiQ bus timing, e.g. clock cycle settings, has not changed since the component last booted:
The DRIVE-CLiQ component boots in cyclic mode.
- The DRIVE-CLiQ timing has changed:
Autonomous operation must continue at all costs. The DRIVE-CLiQ component refuses to boot until the application signals that autonomous operation is no longer required. The component can then restart with the modified clock cycle settings.

For a 2nd download it is possible that the component is already operational. In order that a 2nd download (reparameterization, factory setting, ...) is possible, the DRIVE-CLiQ master must "deactivate" the protective function (if one is selected) and thus also autonomous time-slice operation. All timing changes can be accepted in this state.

The DRIVE-CLiQ master performs a relevance check on the download (only those settings which affect the time-slice behavior of the component are relevant here).

Reconfigurations which must be linked to the DRIVE-CLiQ slave with message "Timing change" are

- Changes to the DRIVE-CLiQ clock cycle for the component.
- Changes to oversampling settings which require internal reconfiguration of the time-slice system.

Please also note the following:

- Changes to component connections and longer cables between components require adjustments to signal propagation delays and therefore also change the timing.

13.14 Licensing

13.14.1 Overview

To use the SINAMICS S120 drive system and the activated options, you need to assign the corresponding licenses to the hardware. When doing so, you receive a license key, which electronically links the relevant option with the hardware.

The license key is an electronic license stamp that indicates that one or more software licenses are owned.

Actual customer verification of the license for the software that is subject to license is called a certificate of license.

Note

Refer to the order documentation (e.g. catalogs) for information on basic functions and functions subject to license.

Properties of the license key

- Is assigned to a specific memory card.
- Is stored retentively on the memory card.
- Is not transferrable.
- Can be acquired using the "WEB License Manager" from a license database.

System responses

System response if there is a not a sufficient license for an option

An insufficient license for an option is indicated via the following alarm and LED on the Control Unit:

- A13000 Insufficient license.
- LED READY Flashes green/red at 0.5 Hz

Note

The drive can only be operated with an insufficient license for an option during commissioning and servicing.

The drive requires a sufficient license in order for it to operate.

System response for an insufficient license for a function module

An insufficient license for a function module is indicated using the following fault and LED on the Control Unit:

- F13010 licensing, function module not licensed.
- The drive is stopped with an OFF1 response.
- LED READY Continuous red light.

Note

It is not possible to operate a drive system with an insufficient license for a function module. The drive requires a sufficient license in order for it to operate.

System response if there is not a sufficient license for an technology extension

An insufficient license for a technology extension (also known under the name "OA application") is indicated via the following alarm and LED on the Control Unit:

- A13000 Insufficient license.
- LED READY Flashes green/red at 0.5 Hz

Note

The drive can only be operated with an insufficient license for a technology extension during commissioning and servicing.

The drive requires a sufficient license in order for it to operate.

Information on performance expansion

The "Performance" option (Article number: 6SL3074-0AA01-0AA0) is required from the 4th axis (for SERVO/VECTOR) or from the 7th U/f axis for the CU320-2 (see Availability of the software functions (Page 1041)s). If the number of axes is exceeded, alarm A13000 is output and the LED READY on the Control Unit flashes green/red at 0.5 Hz.

When using the extended safety functions, a license is required for each axis.

13.14.2 Creating or displaying license keys via the "WEB License Manager"

The WEB License Manager informs you about how many and which licenses are stored on the memory card. If you need additional licenses, you can create a new license key using the WEB License Manager.

Note

A new license is not required for the upgrade. Therefore, do not delete the license key from the memory card (..\KEYS\SINAMICS\KEYS.txt) if you want to upgrade.

The following information is required to work with the "WEB License Manager":

- Memory card serial number (printed on the memory card)
- License number and delivery note number of the license (is on the Certificate of License)
- Product name

Creating a license key

1. Call the following link:

WEB License Manager (https://workplace.automation.siemens.com/pls/swl-pub/SWL_MAIN_MENU.NAVIGATION_HEAD?a_lang_id=E&a_action=)

2. Select the "Direct access" link.

The progress indicator is at "Login" in the License Manager.

3. Enter the license number and delivery note number of your license and then click "Next".

The progress indicator is then at "Identify product".

4. Enter the serial number of the memory card.

5. Select the product that you are using, e.g. "SINAMICS S CU320-2 DP". Then click "Next".

The progress indicator is at "Select licenses". In the "Already assigned licenses" column, you can see which licenses of the selected delivery note have already been assigned and how often.

In the "Additional licenses to be assigned" column, you can activate required licenses or also specify how many additional licenses you require.

6. Activate the additional required licenses and then click "Next".

The progress indicator is at "Assign licenses". A summary of the selected licenses is displayed here for checking.

7. To start the assignment, click "Assign".

A prompt appears.

8. When you are sure that the license has been correctly assigned, click "OK".

The licenses are permanently assigned to the specified hardware. The progress indicator is at "Generate license key". The license key is displayed and can be saved as a text file or as a PDF.

Displaying the license key

If the license key on the memory card is accidentally deleted, you can display it again via the WEB License Manager.

1. Call the following link:

WEB License Manager (https://workplace.automation.siemens.com/pls/swl-pub/SWL_MAIN_MENU_NAVIGATION_HEAD?a_lang_id=E&a_action=)

2. Click the entry "Display license key" under "User" in the navigation.
3. Set the "License number" entry on the right in the drop-down list.
4. Enter your license number in the field below and then click the "Display license key" button.

The current license key is then displayed.

You can request this license key by e-mail in the form of a report. This report contains all previously ordered licenses for this memory card. Missing licenses can be detected and re-ordered on the basis of this report.

5. Enter your address in the "E-mail address" field and then click the "Request license report" button.

13.14.3 Entering the license key in STARTER

With the STARTER commissioning tool, enter the letters and numbers of the license key directly, as specified in the "WEB License Manager". Always enter upper-case letters in parameter p9920.

In this case, STARTER handles the ASCII coding in the background.

Example of a license key: "E1MQ-4BEA"

Note

If several licenses have been ordered for a card, the license key is longer than in the example.

If in addition to the existing license, additional licenses are ordered for a card, the license key must be generated again by the WEB License Manager and re-entered.

Procedure for entering a license key (see example):

p9920[0] = E 1st Character

...

p9920[8] = A 9th Character

Note

When changing p9920[x] to the value 0, all of the following indices are also set to 0. In STARTER, this is performed by deleting the value of p9920[x].

After the license key has been entered, it has to be activated as follows:

- p9921 = 1 (start, activate license key)

The parameter is automatically reset to 0

13.14.4 Entering the license key with BOP20

If you enter the license key via BOP20, you must use the ASCII code of the key. In the table below, you can enter the characters of the license key and the associated decimal numbers.

Table 13- 28 License key table

Character												
Decimal												

ASCII code

Table 13- 29 Excerpt of ASCII code

Character	Decimal	Character	Decimal
-	45	I	73
0	48	J	74
1	49	K	75
2	50	L	76
3	51	M	77
4	52	N	78
5	53	O	79
6	54	P	80
7	55	Q	81
8	56	R	82
9	57	S	83
A	65	T	84
B	66	U	85
C	67	V	86
D	68	W	87
E	69	X	88
F	70	Y	89
G	71	Z	90
H	72	Blank	32

13.14.5 Parameters

Overview of important parameters (see SINAMICS S120/S150 List Manual)

- p9920[0...99] Licensing, enter license key
- p9921 Licensing, activate license key
- r9976[0...7] System utilization

13.15 Write and know-how protection

In order to protect your own projects against changes, unauthorized viewing or copying, SINAMICS S120 has "write protection" and "know-how protection" functions (KHP).

Protection	Validity	Objective	Effect
Write protection	Online	The write protection is used to protect the parameterization from accidental changes by the user.	p-parameters can be read, but cannot be written.
Know-how protection	Online	The know-how protection is used to protect intellectual property, especially the know-how of the machine manufacturers, against unauthorized use or reproduction of their products.	p-parameters can neither be read nor written.

13.15.1 Write protection

Write protection prevents settings from being inadvertently changed. No password is required for write protection.

Setting up and activating write protection

1. Connect the Control Unit to the programming device.
2. Call STARTER.
3. Download your project.
4. Establish a connection to the target device.

- 5. Select the required drive unit in the project navigator of your STARTER project.
- 6. Call the shortcut menu "Write protection drive unit > Activate".

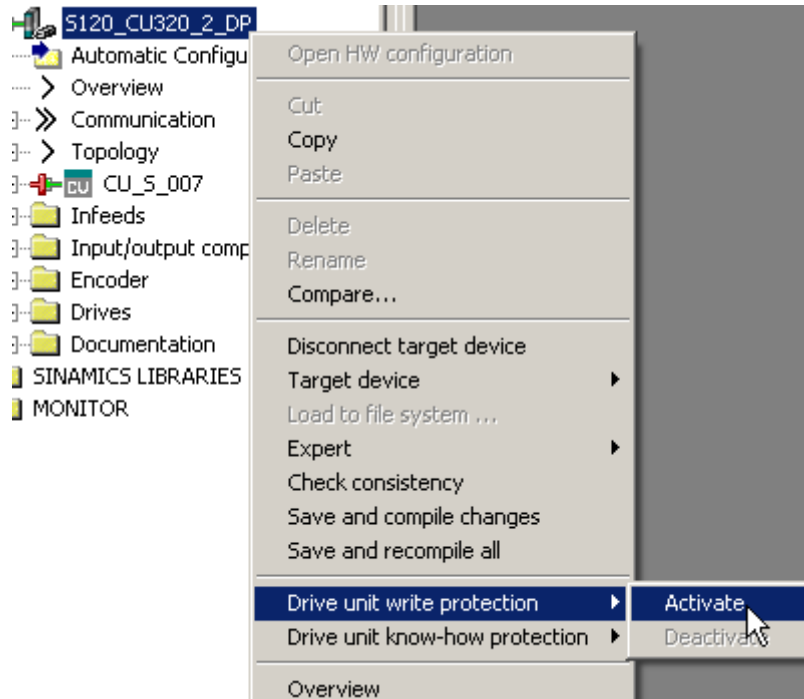

Figure 13-27 Activating write protection

Write protection is now activated. In the expert list you can recognize that write protection is active by the fact that the entry fields of all adjustable parameters are shown with gray shading.

In order to permanently transfer your setting, after changing write protection, you must carry out the "RAM to ROM" data save operation.

Note

Know-how protection with active write protection

If write protection is active, the know-how protection setting cannot be changed.

Note

Access via fieldbus

Per default, in spite of write protection, parameters can be changed via fieldbusses with acyclic access. If write protection should also be active for access operations via fieldbusses, then in the expert list, you must set p7762 to 1.

Deactivating write protection

1. Connect the Control Unit to the programming device.
2. Call STARTER.
3. Download your project.
4. Establish a connection to the target device.
5. Select the required drive unit in the project navigator of your STARTER project.
6. Call the shortcut menu "Write protection drive unit > Deactivate".

The hatching in the expert list disappears after deactivation. The parameters can be set again.

Parameters without write protection

Certain parameters are excluded from the write protection in order not to restrict the functionality and operability of the drives. The list of these parameters can be found in the SINAMICS S120/150 List Manual in Section "Parameters for write protection and know-how protection", Subsection "Parameters with WRITE_NO_LOCK".

The "Restore factory settings" function can also be used when write protection is activated.

13.15.2 Know-how protection

The "Know-how protection" function prevents, for example, strictly confidential company know-how for configuration and parameter assignment from being read by unauthorized persons.

The know-how protection requires a password. The password must comprise at least 1 and a maximum of 30 characters.

Note

Password security

You are responsible for the security of your password. Whenever possible, use a password with sufficient length (min. eight characters); use upper- and lower-case letters and special characters.

The know-how protection is a pure online function. Therefore, establish a direct connection to the Control Unit before setting the password.

Characteristics when know-how protection is activated

- Except for a small number of system parameters and the parameters specified in an exception list, all other parameters are locked.
- The values of these parameters are not visible in the expert list and so cannot be changed. The text "know-how protected" appears instead of the parameter values.
- Know-how protected parameters can be hidden in the expert list. This requires that the "not know-how protected" filter is set in the "Online value" column.
- The values of display parameters remain visible.
- The contents of screen forms are not displayed when know-how protection is active.
- Know-how protection can be combined with copy protection.
- The same know-how protection is used for scripts.
- The drive unit as well as the drive objects and DCC charts therein can be displayed as inconsistent.

Functions locked using know-how protection

The following listed functions are inhibited when know-how protection is active:

- Download
- Automatic controller setting
- Stationary/rotating measurement
- Deleting the alarm history
- Creating acceptance documentation

Functions that can be executed for know-how protection

The following listed functions can still be executed despite of the fact that know-how protection is activated:

- Restoring factory settings
- Acknowledging alarms
- Displaying alarms and warnings
- Displaying the alarm history
- Reading out the diagnostic buffer
- Switching over to the control panel (fetch the master control, all the buttons and setting parameters)
- Displaying created acceptance documentation

Functions that can be executed optionally for know-how protection

The functions listed below can be executed despite activated know-how protection provided diagnostic functions were permitted when it was activated:

- Trace function
- Function generator
- Measuring function

Functions that can only be partly executed with know-how protection

The following listed functions can only be partly executed when know-how protection is active:

- Displaying the topology (actual topology only)
- Upload (restricted scope; see OEM exception list (Page 1013))

Parameters that can be changed when know-how protection is active

In spite of active know-how protection, certain parameters can be changed and read. The list of these parameters can be found in the SINAMICS S120/S150 List Manual in Section "Parameters for write protection and know-how protection", Subsection "Parameters with "KHP_WRITE_NO_LOCK".

Parameters that can be read when know-how protection is active

In spite of know-how protection being active, additional parameters can be read, but are locked against changes. The list of these parameters can be found in the SINAMICS S120/S150 List Manual in Section "Parameters for write protection and know-how protection", Subsection "Parameters with KHP_ACTIVE_READ".

Note

Password check for know-how protection

Please note that if the Windows language settings are changed, after activating know-how protection, errors can occur when subsequently checking the password. If you use language-specific special characters, you must ensure that the same language setting is active on the computer for subsequent entry of the password.

Note

Data security of the memory card

After setting up and activating the know-how protection, for encrypted data backup on the memory card, previously backed up, non-encrypted data of the SINAMICS software will be deleted. This is standard deletion procedure, in which only the entries on the memory card are deleted. The data itself is still available and can be reconstructed.

To ensure know-how protection, we recommend the use of a new empty memory card. If you cannot obtain a new memory card in the short term, you should delete all safety-related data on the current memory card.

To completely delete your previous data on the memory card, you must reliably delete this data using a suitable PC tool before activating know-how protection. The data is located on the memory card in the "\\USER\SINAMICS\DATA" directory.

 **WARNING**

Danger to life through software manipulation when using removable storage media

The storage of files on removable storage media involves a high risk of infection, e.g. via viruses or malware. As a result of incorrect parameterization, machines can malfunction, which in turn can lead to injuries or death.

- Protect the files on removable storage media against harmful software through appropriate protective measures, e.g. virus scanners.
-

Note

Diagnostics under know-how protection

If service or diagnostics is to be performed when know-how protection is active, then Siemens AG can only provide support in collaboration with the OEM partner.

13.15.2.1 Copy protection

Features of the activated copy protection

The copy protection prevents the project from being copied to other memory cards and possibly used on other Control Units. Additional features include:

- Copy protection can only be activated in conjunction with the know-how protection (see Chapter "Activating know-how protection (Page 1014)").
- Depending on the selected copy-protection option, when the know-how protection is activated, it is either linked only to the memory card or to the memory card and the Control Unit together.
- The copy protection prevents the use of copied memory cards. When extended copy protection is selected, the use of the original memory card is also not permitted on other Control Units.
- With the exception of the DCC library, the copy-protected data on the memory card cannot be read or copied. If a copied memory card is used, a copy protection error is displayed and a pulse inhibit set.

13.15.2.2 Configuring know-how protection

Requirements

Before activating know-how protection, the following conditions must be met:

- The drive unit has been fully commissioned.
(Configuration, download into the drive unit, complete commissioning. You have then carried out an upload in order to upload the parameters calculated by the drive into the STARTER project.)
- The OEM exception list has been created (see below).
- To guarantee know-how protection, you must ensure that the project does not remain at the end user as a file.

Creating the OEM exception list

Before activating the know-how protection, enter the parameters in this exception list that are to remain readable and writable despite the know-how protection. The exception list can only be created via the expert list. The exception list has no influence on the input screen forms in STARTER.

Note

Parameters belonging to the OEM exception list can be viewed everywhere

All parameters in the OEM exception list can be viewed in the web server and other commissioning tools, even when know-how protection is activated.

Therefore make sure that no critical parameters are entered in the OEM exception list.

Factory setting for the exception list:

- p7763 = 1 (exception list contains precisely one parameter)
- p7764[0] = 7766 (parameter number for entering the password)

Procedure

1. Use parameter p7763 to define the required number of parameters for the exception list.
You can enter a maximum of 500 parameters in the exception list.
2. Execute the "Load to PG" function.
Parameter p7764 is adapted in the expert list according to the setting in p7763. Indices are inserted or deleted depending on the setting.
3. In parameter p7764[0...n], assign the individual indices of p7763 to the required parameter numbers.
4. Transfer the changes to the Control Unit so that they can become effective.

Note

Parameters of the exception list are not checked

The Control Unit does not check which parameters you include or delete in the exception list.

Absolute know-how protection

By removing parameter p7766 from the exception list of p7764[0] = 0, you prevent any access at all to the data of the Control Unit and your project settings. It is then impossible to read or change the protected data. The know-how protection and the copy protection can no longer be canceled or deactivated.

Activate know-how protection

1. Connect the Control Unit to the programming device.
2. Call STARTER.
3. Open your project.
4. Establish a connection to the target device.
5. Select the required drive unit in the project navigator of your STARTER project.

6. In the shortcut menu, select "Drive unit know-how protection > Activate".

The "Activate Know-how Protection for Drive Object" dialog box opens.

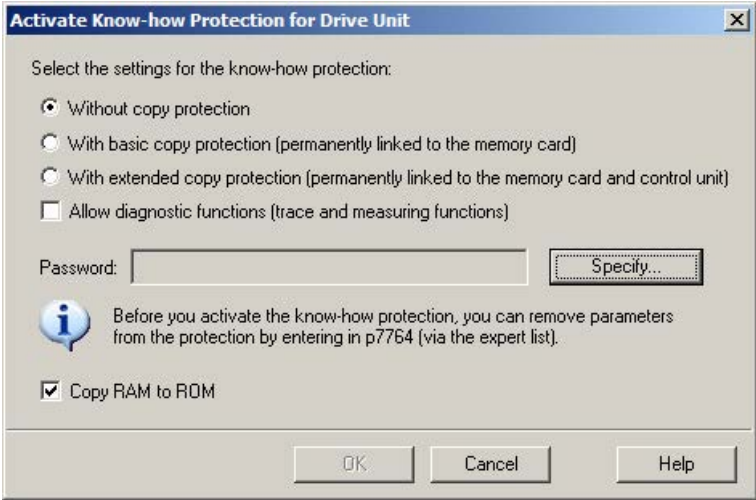



Figure 13-28 Activating

7. The "Without copy protection" option is active by default. When an appropriate memory card is inserted in the Control Unit, you can choose from two copy-protection options:
- With basic copy protection (permanently linked to the memory card)
 - With extended copy protection (permanently linked to the memory card and Control Unit)

 WARNING
Danger to life through software manipulation when using removable storage media
The storage of files on removable storage media involves a high risk of infection, e.g. via viruses or malware. As a result of incorrect parameterization, machines can malfunction, which in turn can lead to injuries or death.
<ul style="list-style-type: none">• Protect the files on removable storage media against harmful software through appropriate protective measures, e.g. virus scanners.

8. Click "Specify".

The "Know-how Protection for Drive Unit - Specify Password" dialog box opens.

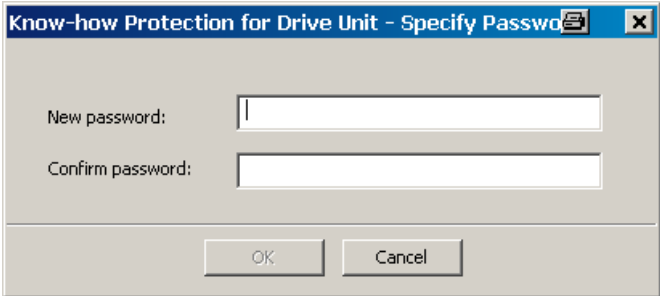

Figure 13-29 Setting the password

13.15 Write and know-how protection

9. In the "New password" field, enter the password (1 to 30 characters). Pay attention to upper- and lower-case.

10. Enter it again in the "Confirm password" field and click "OK" to confirm the entry.

The dialog box is closed and the password is shown in encrypted form in the "Activate Know-how Protection for Drive Object" dialog box.

11. If, despite active know-how protection, you permit diagnostic functions, activate the "Allow diagnostic functions (trace and measuring functions)" option with a mouse click.

This allows the trace function, the measuring function and the function generator to be used despite know-how protection.

12. The "Copy RAM to ROM" option is active by default and ensures that the know-how protection is permanently stored in the Control Unit. If you want to use the know-how protection temporarily, deactivate this option.

13. Click "OK".

Know-how protection is now activated. If larger data volumes are being encrypted, a progress display informs that the encryption or the activation of the know-how protection is still running.

The text "Know-how protected" then appears instead of the content in all protected parameters of the expert list.

Note

For published DCC parameters, the entry "--" appears in the expert list instead of the text "Know-how protected".

Deactivating know-how protection

1. Connect the Control Unit to the programming device.
2. Call STARTER.
3. Open your project.
4. Establish a connection to the target device.
5. Select the required drive unit in the project navigator of your STARTER project.
6. In the shortcut menu, select "Drive unit know-how protection > Deactivate"

The "Deactivate Know-how Protection for Drive Unit" dialog box opens.

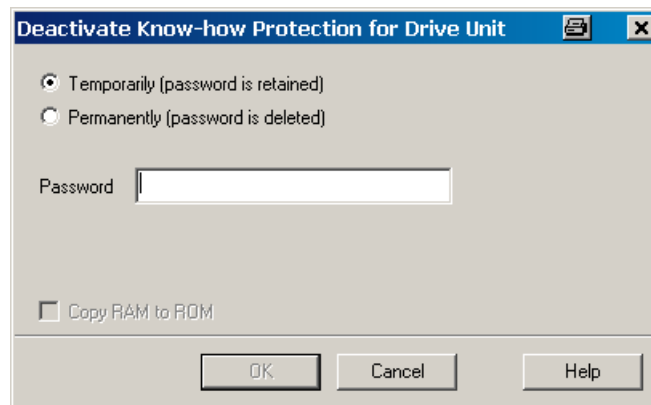

Figure 13-30 Deactivating

7. Select whether you want to deactivate the know-how protection "Temporarily" or "Permanently" by clicking the corresponding checkbox.
 - "Temporarily" deactivating: Know-how protection is active again after switching off and switching on.
 - "Permanently" deactivating: Know-how protection remains deactivated even after switching off and switching on again.

If you select "Permanently", you can also carry out a data backup on the Control Unit with "Copy RAM to ROM". The checkbox with the same name is active in this case and is automatically activated. If you deactivate this checkbox, you must perform a manual RAM to ROM data backup later if the know-how protection remains deactivated after switching off and on.

8. Enter your password, and click "OK".

Know-how protection is now deactivated. If larger data volumes are being decrypted, a progress display informs that the decryption or the deactivation of the know-how protection is still running. The values of all parameters are displayed again in the expert list.

Changing the password

A password can only be changed for an activated know-how protection.

To change the password for the know-how protection, proceed as follows:

1. Connect the Control Unit to the programming device.
2. Call STARTER.
3. Open your project.
4. Select the required drive unit in the project navigator of your STARTER project.
5. Call the shortcut menu "Drive unit know-how protection > Change password".

The "Change Password" dialog box opens.

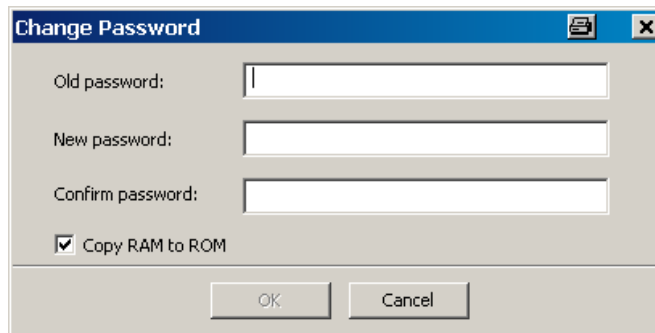

Figure 13-31 Changing the password

6. Enter your old password in the uppermost text box.
7. Enter your new password in the following text box and repeat it in the lowest text box.
8. The "Copy RAM to ROM" option is active by default and ensures that the new password for the know-how protection is permanently stored in the Control Unit. If you only want to change the password temporarily, you can deactivate this option.
9. Click "OK" to close the dialog box.

Once the password has been changed successfully, you will receive a confirmation.

13.15.2.3 Loading know-how protected data to the file system

Data with know-how protection can be directly loaded or saved to the file system from the drive unit. The activated know-how protection ensures that the data cannot be forwarded to unauthorized third parties.

The following applications are conceivable at the end user:

- Adaptations of encrypted SINAMICS data are required.
- The memory card is defective.
- The Control Unit of the drive is defective.

In these cases, the OEM can create a new encrypted subproject (for a drive object) via STARTER. The serial number of a new memory card or a new Control Unit is saved in this encrypted data record in advance.

Application example: Control Unit is defective

Scenario:

The Control Unit of an end user is defective. The machine manufacturer (OEM) has the end user's STARTER project files of the machine.

Sequence:

1. The end user sends the OEM the serial numbers of the new Control Unit (r7758) and the new memory card (r7843), and specifies the machine in which the Control Unit is installed.
2. The OEM loads the STARTER project data of the end user.
3. The OEM performs the STARTER function "Load to file system" (see Chapter Save data to the file system (Page 1018)).
 - The OEM specifies whether the data is to be stored zipped or unzipped.
 - The OEM makes the required know-how protection settings.
4. The OEM sends the stored data to the end user (e.g. by e-mail).
5. The end user copies the "User" directory to the new memory card and inserts it into the new Control Unit.
6. The end user switches on the drive.

When powering up, the Control Unit checks the new serial numbers and deletes the values p7759 and p7769 if they match.

After it has powered-up without any errors, the Control Unit is ready for operation. The know-how protection is active.

If the serial numbers do not match, then fault F13100 is output.

If required, the end user must re-enter the changed parameters from the OEM exception lists.

Calling the "Load to File System" dialog box

1. Call STARTER.
2. Open the required project.
3. Select the required drive unit in the project navigator of your STARTER project.
4. Call the "Load to file system" function.

The "Load to File System" dialog box opens.

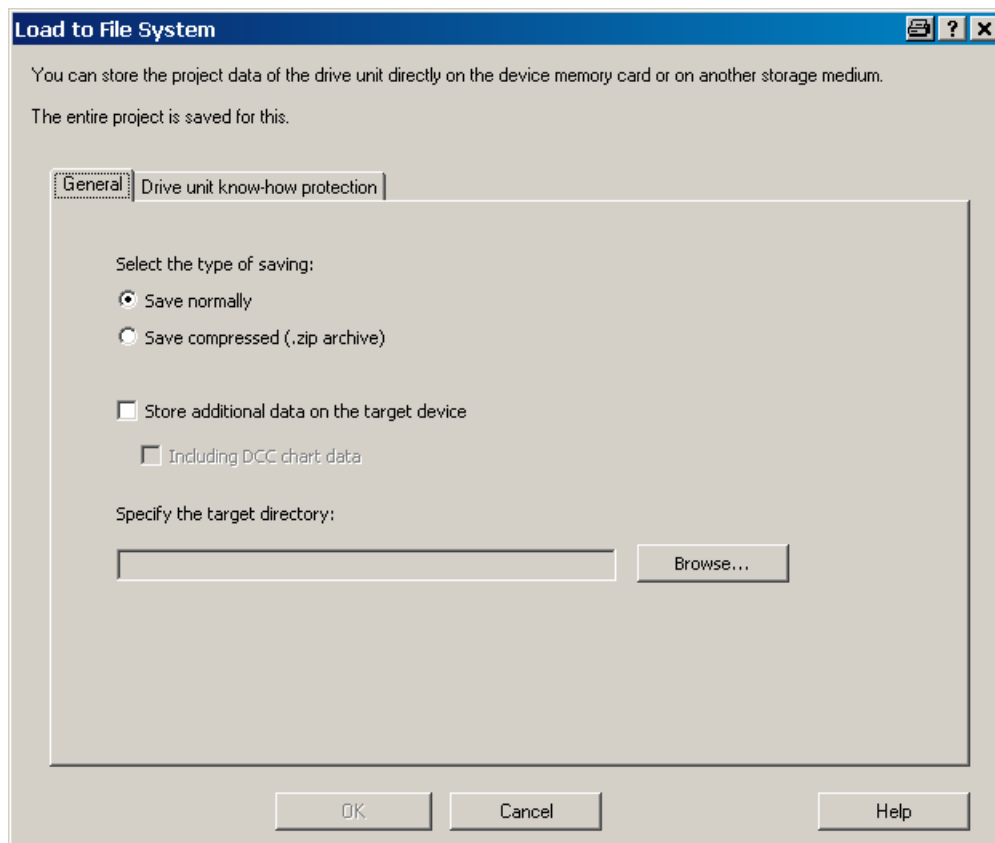

Figure 13-32 Load to file system (default setting)

Specifying the general memory data

The "General" tab is displayed automatically when the dialog is called. The "Save normally" option is activated by default.

1. If you want to save the data in compressed form, click the "Save compressed (.zip archive)" option button.

The "Store additional data on the target device" option is deactivated in the default setting.

2. If you want to store additional data, such as program sources, on the target device, activate this option.
 - Optionally you can also activate "Including DCC chart data". Graphical chart data can then also be stored.
3. Enter the path for the storage directory in the appropriate input field, or click "Browse" and select the directory in your file system.

Configuring know-how protection

Make the settings for the know-how protection on the "Drive unit know-how protection" tab.

1. Click the "Drive unit know-how protection" tab.

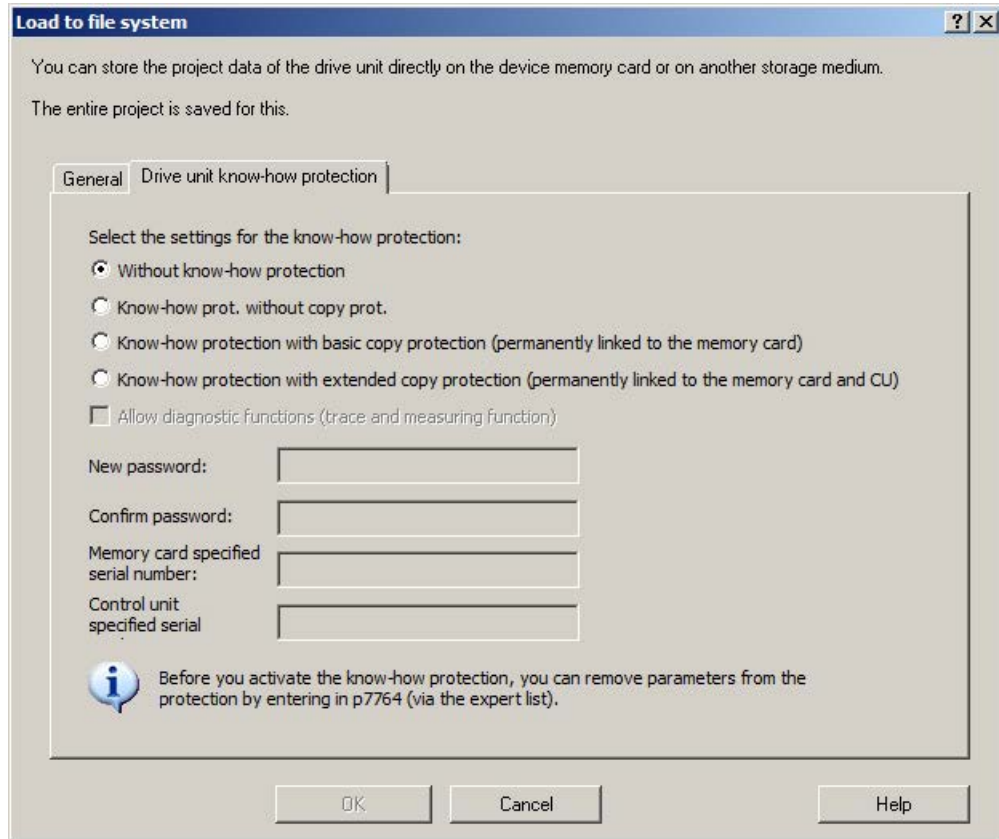

Figure 13-33 Load to file system know-how protection

By default, the "Without know-how protection" option is active. If you really want to store the data without protection (not recommended), you can exit the dialog box with "OK" or "Cancel" at this point.

2. If you want to store with protection, activate one of the following options with a mouse click:
 - "Know-how prot. without copy prot."
Required inputs: "New password" and "Confirm password"
 - "Know-how protection with basic copy protection (permanently linked to the memory card)"
Required inputs: "New password", "Confirm password" and "Memory card specified serial number"
 - "Know-how protection with extended copy protection (permanently linked to the memory card and CU)"
Required inputs: "New password", "Confirm password" "Memory card specified serial number" and "Control unit specified serial number"

The input fields for the passwords and the serial numbers appropriate for the activated know-how protection are then active.

Select the settings for the know-how protection:

Without know-how protection

Know-how prot. without copy prot.

Know-how protection with basic copy protection (permanently linked to the memory card)

Know-how protection with extended copy protection (permanently linked to the memory card and CU)

Allow diagnostic functions (trace and measuring function)

New password:

Confirm password:

Memory card specified serial number:

Control unit specified serial:

Figure 13-34 Activating load to file system know-how protection

The active input fields are mandatory inputs.

3. Enter the required password in the "New password" field and enter it again in the "Confirm password" field.
4. If the associated input fields are active, enter the serial numbers:
 - The serial number of the new memory card for which the data is intended
 - The serial number of the Control Unit
5. If, despite active know-how protection, you permit diagnostic functions, activate the "Allow diagnostic functions (trace and measuring function)" option with a mouse click.

This allows the trace function, the measuring function and the function generator to be used despite know-how protection.
6. Click "OK" to confirm the settings you made.

Result

The activation of the know-how protection starts the encryption of the subproject data. If larger data volumes are being encrypted, a progress display informs that the encryption or the activation of the know-how protection is still running. With the aid of this encrypted data, an end user can install a new memory card for the drive unit.

13.15.3 Overview of important parameters

Overview of important parameters (see SINAMICS S120/S150 List Manual)

- r7758[0...19] KHP Control Unit serial number
- p7759[0...19] KHP Control Unit reference serial number
- r7760 Write protection / know-how protection status
- p7761 Write protection
- p7762 Write protection multi-master fieldbus system access behavior
- p7763 KHP OEM exception list number of indices for p7764
- p7764[0...n] KHP OEM exception list
- p7765 KHP configuration
- p7766[0...29] KHP password input
- p7767[0...29] KHP password new
- p7768[0...29] KHP password confirmation
- p7769[0...20] KHP memory card reference serial number
- r7843[0...20] Memory card serial number

Appendix

A.1 List of abbreviations

Note

The following list of abbreviations includes all abbreviations and their meanings used in the entire SINAMICS family of drives.

Abbreviation	Source of abbreviation	Significance
A		
A...	Alarm	Warning
AC	Alternating Current	Alternating current
ADC	Analog Digital Converter	Analog-Digital converter
AI	Analog Input	Analog input
AIM	Active Interface Module	Active Interface Module
ALM	Active Line Module	Active Line Module
AO	Analog Output	Analog output
AOP	Advanced Operator Panel	Advanced Operator Panel
APC	Advanced Positioning Control	Advanced Positioning Control
AR	Automatic Restart	Automatic restart
ASC	Armature Short Circuit	Armature short-circuit
ASCII	American Standard Code for Information Interchange	American coding standard for the exchange of information
AS-i	AS-Interface (Actuator Sensor Interface)	AS-interface (open bus system in automation technology)
ASM	Asynchronmotor	Induction motor
B		
BB	Betriebsbedingung	Operation condition
BERO	-	Contactless proximity switch
BI	Binector Input	Binector input
BIA	Berufsgenossenschaftliches Institut für Arbeitssicherheit	BG-Institute for Occupational Safety and Health
BICO	Binector Connector Technology	Binector connector technology
BLM	Basic Line Module	Basic Line Module

Abbreviation	Source of abbreviation	Significance
BO	Binector Output	Binector output
BOP	Basic Operator Panel	Basic operator panel
C		
C	Capacitance	Capacitance
C...	-	Safety message
CAN	Controller Area Network	Serial bus system
CBC	Communication Board CAN	Communication Board CAN
CBE	Communication Board Ethernet	PROFINET communication module (Ethernet)
CD	Compact Disc	Compact disk
CDS	Command Data Set	Command data set
CF Card	CompactFlash Card	CompactFlash card
CI	Connector Input	Connector input
CLC	Clearance Control	Clearance control
CNC	Computerized Numerical Control	Computer-supported numerical control
CO	Connector Output	Connector output
CO/BO	Connector Output / Binector Output	Connector Output / Binector Output
COB ID	CAN Object-Identification	CAN Object-Identification
CoL	Certificate of License	Certificate of License
COM	Common contact of a changeover relay	Center contact of a changeover contact
COMM	Commissioning	Startup
CP	Communication Processor	Communications processor
CPU	Central Processing Unit	Central processing unit
CRC	Cyclic Redundancy Check	Cyclic redundancy check
CSM	Control Supply Module	Control Supply Module
CU	Control Unit	Control Unit
CUA	Control Unit Adapter	Control Unit Adapter
CUD	Control Unit DC	Control Unit DC
D		
DAC	Digital Analog Converter	Digital analog converter
DC	Direct Current	DC current
DCB	Drive Control Block	Drive Control Block
DCBRK	DC Brake	DC braking
DCC	Drive Control Chart	Drive Control Chart
DCN	Direct Current Negative	Direct current negative
DCP	Direct Current Positive	Direct current positive
DDC	Dynamic Drive Control	Dynamic Drive Control
DDS	Drive Data Set	Drive Data Set
DI	Digital Input	Digital input
DI/DO	Digital Input / Digital Output	Digital input/output, bidirectional
DMC	DRIVE-CLiQ Hub Module Cabinet	DRIVE-CLiQ Hub Module Cabinet

Abbreviation	Source of abbreviation	Significance
DME	DRIVE-CLiQ Hub Module External	DRIVE-CLiQ Hub Module External
DMM	Double Motor Module	Double Motor Module
DO	Digital Output	Digital output
DO	Drive Object	Drive object
DP	Decentralized Peripherals	Distributed I/O
DPRAM	Dual-Port Random Access Memory	Dual-Port Random Access Memory
DQ	DRIVE-CLiQ	DRIVE-CLiQ
DRAM	Dynamic Random Access Memory	Dynamic Random Access Memory
DRIVE-CLiQ	Drive Component Link with IQ	Drive Component Link with IQ
DSC	Dynamic Servo Control	Dynamic Servo Control
DTC	Digital Time Clock	Timer
E		
EASC	External Armature Short-Circuit	External armature short-circuit
EDS	Encoder Data Set	Encoder data set
EEPROM	Electrically Erasable Programmable Read-Only Memory	Electrically Erasable Programmable Read-Only-Memory
EGB	Elektrostatisch gefährdete Baugruppen	Electrostatic sensitive devices
ELCB	Earth Leakage Circuit-Breaker	Residual current operated circuit breaker
ELP	Earth Leakage Protection	Ground-fault monitoring
EMC	Electromagnetic Compatibility	Electromagnetic compatibility
EMF	Electromotive Force	Electromotive force
EMK	Elektromotorische Kraft	Electromotive force
EMV	Elektromagnetische Verträglichkeit	Electromagnetic compatibility
EN	Europäische Norm	European Standard
EnDat	Encoder-Data-Interface	Encoder interface
EP	Enable Pulses	Pulse enable
EPOS	Einfachpositionierer	Basic positioner
ES	Engineering System	Engineering system
ESB	Ersatzschaltbild	Equivalent circuit diagram
ESD	Electrostatically Sensitive Devices	Electrostatic sensitive devices
ESM	Essential Service Mode	Essential service mode
ESR	Extended Stop and Retract	Extended stop and retract
F		
F...	Fault	Fault
FAQ	Frequently Asked Questions	Frequently Asked Questions
FBLOCKS	Free Blocks	Free function blocks
FCC	Function control chart	Function control chart
FCC	Flux Current Control	Flux current control
FD	Function Diagram	Function diagram
F-DI	Fail-safe Digital Input	Failsafe digital input

Abbreviation	Source of abbreviation	Significance
F-DO	Fail-safe Digital Output	Fail-safe digital output
FEPRM	Flash-EPROM	Non-volatile write and read memory
FG	Function Generator	Function Generator
FI	-	Fault current
FOC	Fiber-Optic Cable	Fiber-optic cable
FP	Funktionsplan	Function diagram
FPGA	Field Programmable Gate Array	Field Programmable Gate Array
FW	Firmware	Firmware
G		
GB	Gigabyte	Gigabyte
GC	Global Control	Global control telegram (broadcast telegram)
GND	Ground	Reference potential for all signal and operating voltages, usually defined as 0 V (also referred to as M)
GSD	Gerätstammdatei	Generic Station Description: Describes the features of a PROFIBUS slave
GSV	Gate Supply Voltage	Gate supply voltage
GUID	Globally Unique Identifier	Globally Unique Identifier
H		
HF	High Frequency	High frequency
HFD	Hochfrequenzdrossel	Radio frequency reactor
HLA	Hydraulic Linear Actuator	Hydraulic linear actuator
HLG	Hochlaufgeber	Ramp-function Generator
HM	Hydraulic Module	Hydraulic Module
HMI	Human Machine Interface	Human Machine Interface
HTL	High-Threshold Logic	Logic with high interference threshold
HW	Hardware	Hardware
I		
i. V.	In Vorbereitung	Under development: This property is currently not available
I/O	Input/Output	Input/output
I2C	Inter-Integrated Circuit	Internal serial data bus
IASC	Internal Armature Short-Circuit	Internal armature short-circuit
IBN	Inbetriebnahme	Startup
ID	Identifier	Identification
IE	Industrial Ethernet	Industrial Ethernet
IEC	International Electrotechnical Commission	International Electrotechnical Commission
IF	Interface	Interface
IGBT	Insulated Gate Bipolar Transistor	Insulated gate bipolar transistor
IGCT	Integrated Gate-Controlled Thyristor	Semiconductor power switch with integrated control electrode

Abbreviation	Source of abbreviation	Significance
IL	Impulslöschung	Pulse suppression
IP	Internet Protocol	Internet protocol
IPO	Interpolator	Interpolator
IT	Isolé Terre	Non-grounded three-phase line supply
IVP	Internal Voltage Protection	Internal voltage protection
J		
JOG	Jogging	Jogging
K		
KDV	Kreuzweiser Datenvergleich	Data cross-check
KHP	Know-How Protection	Know-how protection
KIP	Kinetische Pufferung	Kinetic buffering
Kp	-	Proportional gain
KTY84	-	Temperature sensor
L		
L	-	Symbol for inductance
LED	Light Emitting Diode	Light emitting diode
LIN	Linearmotor	Linear motor
LR	Lageregler	Position controller
LSB	Least Significant Bit	Least Significant Bit
LSC	Line-side converter	Line-side converter
LSS	Line-Side Switch	Line-side switch
LU	Length Unit	Length unit
LWL	Lichtwellenleiter	Fiber-optic cable
M		
M	-	Symbol for torque
M	Masse	Reference potential for all signal and operating voltages, usually defined as 0 V (also referred to as GND)
MB	Megabyte	Megabyte
MCC	Motion Control Chart	Motion Control Chart
MDI	Manual Data Input	Manual data input
MDS	Motor Data Set	Motor data set
MLFB	Maschinenlesbare Fabrikatebezeichnung	Machine-readable product code
MM	Motor Module	Motor Module
MMC	Man-Machine Communication	Man-machine communication
MMC	Micro Memory Card	Micro memory card
MSB	Most Significant Bit	Most significant bit
MSC	Motor Side Converter	Motor-side converter
MSCY_C1	Master Slave Cycle Class 1	Cyclic communication between master (class 1) and slave

A.1 List of abbreviations

Abbreviation	Source of abbreviation	Significance
MSC	Motorstromrichter	Motor-side converter
MT	Messtaster	Probe
N		
N. C.	Not Connected	Not connected
N...	No Report	No report or internal message
NAMUR	Normenarbeitsgemeinschaft für Mess- und Regeltechnik in der chemischen Industrie	Standardization association for measurement and control in chemical industries
NC	Normally Closed (contact)	NC contacts
NC	Numerical Control	Numerical control
NEMA	National Electrical Manufacturers Association	Standardization association in USA (United States of America)
NM	Nullmarke	Zero mark
NO	Normally Open (contact)	NO contacts
NSR	Netzstromrichter	Line-side converter
NVRAM	Non-Volatile Random Access Memory	Non-volatile read/write memory
O		
OA	Open Architecture	Software component which provides additional functions for the SINAMICS drive system
OAIF	Open Architecture Interface	Version of the SINAMICS firmware as of which the OA-application can be used
OASP	Open Architecture Support Package	Expands the STARTER commissioning tool by the corresponding OA-application
OC	Operating Condition	Operation condition
OEM	Original Equipment Manufacturer	Original equipment manufacturer
OLP	Optical Link Plug	Bus connector for fiber-optic cable
OMI	Option Module Interface	Option Module Interface
P		
p...	-	Adjustable parameters
P1	Processor 1	CPU 1
P2	Processor 2	CPU 2
PB	PROFIBUS	PROFIBUS
PcCtrl	PC Control	Master control
PD	PROFIdrive	PROFIdrive
PDC	Precision Drive Control	Precision Drive Control
PDS	Power Unit Data Set	Power unit data set
PE	Protective Earth	Protective ground
PELV	Protective Extra-Low Voltage	Safety extra-low voltage
PFH	Probability of dangerous failure per hour	Probability of dangerous failure per hour
PG	Programmiergerät	Programming device
PI	Proportional integral	Proportional integral
PID	Proportional integral differential	Proportional integral differential

Abbreviation	Source of abbreviation	Significance
PLC	Programmable Logic Controller	Programmable logic controller
PLL	Phase-locked loop	Phase-locked loop
PM	Power Module	Power Module
PMSM	Permanent-Magnet Synchronous Motor	Permanent-magnet synchronous motor
PN	PROFINET	PROFINET
PNO	PROFIBUS Nutzerorganisation	PROFIBUS user organization
PPI	Point-to-Point Interface	Point-to-point interface
PRBS	Pseudo Random Binary Signal	White noise
PROFIBUS	Process Field Bus	Serial data bus
PS	Power Supply	Power supply
PSA	Power Stack Adapter	Power Stack Adapter
PT1000	-	Temperature sensor
PTC	Positive Temperature Coefficient	Positive temperature coefficient
PTP	Point-To-Point	Point-to-point
PWM	Pulse Width Modulation	Pulse width modulation
PZD	Prozessdaten	Process data
Q		
R		
r...	-	Display parameters (read only)
RAM	Random Access Memory	Speicher zum Lesen und Schreiben
RCCB	Residual Current Circuit Breaker	Residual current operated circuit breaker
RCD	Residual Current Device	Residual current operated circuit breaker
RCM	Residual Current Monitor	Residual current monitor
REL	Reluctance motor textile	Reluctance motor textile
RESM	Reluctance Synchronous Motor	Synchronous reluctance motor
RFG	Ramp-Function Generator	Ramp-function Generator
RJ45	Registered Jack 45	Term for an 8-pin socket system for data transmission with shielded or non-shielded multi-wire copper cables
RKA	Rückkühlanlage	Cooling unit
RLM	Renewable Line Module	Renewable Line Module
RO	Read Only	Read only
ROM	Read-Only Memory	Read-only memory
RPDO	Receive Process Data Object	Receive Process Data Object
RS232	Recommended Standard 232	Interface standard for a cable-connected serial data transmission between a sender and receiver (also known as EIA232)
RS485	Recommended Standard 485	Interface standard for a cable-connected differential, parallel, and/or serial bus system (data transmission between a number of senders and receivers, also known as EIA485)

Abbreviation	Source of abbreviation	Significance
RTC	Real-Time Clock	Real-time clock
RZA	Raumzeigerapproximation	Space-vector approximation
S		
S1	-	Continuous operation
S3	-	Intermittent duty
SAM	Safe Acceleration Monitor	Safe acceleration monitoring
SBC	Safe Brake Control	Safe brake control
SBH	Sicherer Betriebshalt	Safe operating stop
SBR	Safe Brake Ramp	Safe brake ramp monitoring
SBT	Safe Brake Test	Safe brake test
SCA	Safe Cam	Safe cam
SCC	Safety Control Channel	Safety Control Channel
SD Card	SecureDigital Card	Secure digital memory card
SDC	Standard Drive Control	Standard Drive Control
SDI	Safe Direction	Safe motion direction
SE	Sicherer Software-Endschalter	Safe software limit switch
SESM	Separately Excited Synchronous Motor	Separately excited synchronous motor
SG	Sicher reduzierte Geschwindigkeit	Safely-limited speed
SGA	Sicherheitsgerichteter Ausgang	Safety-related output
SGE	Sicherheitsgerichteter Eingang	Safety-related input
SH	Sicherer Halt	Safe stop
SI	Safety Integrated	Safety Integrated
SIC	Safety Info Channel	Safety Info Channel
SIL	Safety Integrity Level	Safety Integrity Level
SITOP	-	Siemens power supply system
SLM	Smart Line Module	Smart Line Module
SLP	Safely Limited Position	Safely Limited Position
SLS	Safely-Limited Speed	Safely-limited speed
SLVC	Sensorless Vector Control	Sensorless vector control
SM	Sensor Module	Sensor Module
SMC	Sensor Module Cabinet	Sensor Module Cabinet
SME	Sensor Module External	Sensor Module External
SMI	SINAMICS Sensor Module Integrated	SINAMICS Sensor Module Integrated
SMM	Single Motor Module	Single Motor Module
SN	Sicherer Software-Nocken	Safe software cam
SOS	Safe Operating Stop	Safe operating stop
SP	Service Pack	Service pack
SP	Safe Position	Safe position
SPC	Setpoint Channel	Setpoint channel
SPI	Serial Peripheral Interface	Serial peripheral interface

Abbreviation	Source of abbreviation	Significance
SPS	Speicherprogrammierbare Steuerung	Programmable logic controller
SS1	Safe Stop 1	Safe Stop 1 (monitored for time and ramp)
SS1E	Safe Stop 1 External	Safe Stop 1 with external stop
SS2	Safe Stop 2	Safe Stop 2
SS2E	Safe Stop 2 External	Safe Stop 2 with external stop
SSI	Synchronous Serial Interface	Synchronous serial interface
SSM	Safe Speed Monitor	Safe feedback from speed monitor
SSP	SINAMICS support package	SINAMICS support package
STO	Safe Torque Off	Safe torque off
STW	Steuerwort	Control word
T		
TB	Terminal Board	Terminal Board
TEC	Technology Extension	Software component which is installed as an additional technology package and which expands the functionality of SINAMICS (previously OA-application)
TIA	Totally Integrated Automation	Totally Integrated Automation
TM	Terminal Module	Terminal Module
TN	Terre Neutre	Grounded three-phase line supply
Tn	-	Integral time
TPDO	Transmit Process Data Object	Transmit Process Data Object
TT	Terre Terre	Grounded three-phase line supply
TTL	Transistor-Transistor Logic	Transistor-Transistor-Logik
Tv	-	Rate time
U		
UL	Underwriters Laboratories Inc.	Underwriters Laboratories Inc.
UPS	Uninterruptible Power Supply	Uninterruptible power supply
USV	Unterbrechungsfreie Stromversorgung	Uninterruptible power supply
UTC	Universal Time Coordinated	Universal time coordinated
V		
VC	Vector Control	Vector control
Vdc	-	DC-link voltage
VdcN	-	Partial DC-link voltage negative
VdcP	-	Partial DC-link voltage positive
VDE	Verband Deutscher Elektrotechniker	Verband Deutscher Elektrotechniker [Association of German Electrical Engineers]
VDI	Verein Deutscher Ingenieure	Verein Deutscher Ingenieure [Association of German Engineers]
VPM	Voltage Protection Module	Voltage Protection Module
Vpp	Volt peak to peak	Volt peak to peak
VSM	Voltage Sensing Module	Voltage Sensing Module

Abbreviation	Source of abbreviation	Significance
W		
WEA	Wiedereinschaltautomatik	Automatic restart
WZM	Werkzeugmaschine	Machine tool
X		
XML	Extensible Markup Language	Extensible markup language (standard language for Web publishing and document management)
Y		
Z		
ZK	Zwischenkreis	DC link
ZM	Zero Mark	Zero mark
ZSW	Zustandswort	Status Word

A.2 Documentation overview

General documentation/catalogs			
SINAMICS	G110	D11.1	- Inverter built-in units 0.12 kW up to 3 kW
	G120	D31	- SINAMICS Inverters for Single-Axis Drives and SIMOTICS Motors
	G130, G150	D11.1	- Inverter built-in units - Inverter cabinet units
	S120, S150	D21.3	- SINAMICS S120 Built-in units in the Chassis format and Cabinet Modules - SINAMICS S150 Drive Converter Cabinet Units
SIMOTION, SINAMICS	S120	PM21	- SIMOTION, SINAMICS S120 and Motors for Production Machines
Manufacturer/service documentation			
SINAMICS	G110		- Getting Started - Operating instructions - List Manuals
	G120		- Getting Started - Operating instructions - Hardware Installation Manuals - Function Manual Safety Integrated - List Manuals
	G130		- Operating instructions - List Manual
	G150		- Operating instructions - List Manual
	GM150, SM120/SM150, GL150, SL150		- Operating instructions - List Manuals
	S110		- Manual - Getting Started - Function Manual - List Manual
	S120		- Getting Started with STARTER - Commissioning Manual with STARTER - Getting Started with Startdrive (available as of Startdrive V14 release) - Commissioning Manual with Startdrive (available as of Startdrive V14 release) - Commissioning Manual CANopen - Function Manual Drive Functions - Function Manual Safety Integrated - Function Manual DCC - List Manual - Manual Control Unit and supplementary system components - Manual LT Booksize - Manual LT Booksize C/D Type - Manual LT Chassis air-cooled - Manual LT Chassis liquid-cooled - Manual Combi - Manual Cabinet Modules - Manual AC Drive - SINAMICS S120M Manual Distributed Drive Technology - SINAMICS HLA System Manual Hydraulic Drive
	S150		- Operating instructions - List Manual
Motors			- Configuration Manuals, Motors
General			- Configuration Manual, EMC Guidelines

A.3 Availability of hardware components

Table A- 1 Hardware components available as of 03.2006

No.	Hardware component	Article number	Version	Revisions
1	AC Drive (CU320, PM340)	refer to the Catalog		New
2	SMC30	6SL3055-0AA00-5CA1		With SSI support
3	DMC20	6SL3055-0AA00-6AA.		New
4	TM41	6SL3055-0AA00-3PA.		New
5	SME120 SME125	6SL3055-0AA00-5JA. 6SL3055-0AA00-5KA.		New
6	BOP20	6SL3055-0AA00-4BA.		New
7	CUA31	6SL3040-0PA00-0AA.		New

Table A- 2 Hardware components available as of 08.2007

No.	Hardware component	Article number	Version	Revisions
1	TM54F	6SL3055-0AA00-3BA.		New
2	Active Interface Module (booksize)	6SL3100-0BE...-AB.		New
3	Basic Line Module (booksize)	6SL3130-1TE...-0AA.		New
4	DRIVE-CLiQ encoder	6FX2001-5.D...-0AA.		New
5	CUA31 Suitable for Safety Extended functions via PROFIsafe and TM54	6SL3040-0PA00-0AA1		New
6	CUA32	6SL3040-0PA01-0AA.		New
7	SMC30 (30 mm wide)	6SL3055-0AA00-5CA2		New

Table A- 3 Hardware components available as of 10.2008

No.	Hardware component	Article number	Version	Revisions
1	TM31	6SL3055-0AA00-3AA1		New
2	TM41	6SL3055-0AA00-3PA1		New
3	DME20	6SL3055-0AA00-6AB.		New
4	SMC20 (30 mm wide)	6SL3055-0AA00-5BA2		New
5	Active Interface Module booksize 16 kW	6SL3100-0BE21-6AB.		New
6	Active Interface Module booksize 36 kW	6SL3100-0BE23-6AB.		New
7	Smart Line Modules booksize compact	6SL3430-6TE21-6AA.		New
8	Motor Modules booksize com- pact	6SL3420-1TE13-0AA. 6SL3420-1TE15-0AA. 6SL3420-1TE21-0AA. 6SL3420-1TE21-8AA. 6SL3420-2TE11-0AA. 6SL3420-2TE13-0AA. 6SL3420-2TE15-0AA.		New
9	Power Modules blocksize liquid cooled	6SL3215-1SE23-0AA. 6SL3215-1SE26-0AA. 6SL3215-1SE27-5UA. 6SL3215-1SE31-0UA. 6SL3215-1SE31-1UA. 6SL3215-1SE31-8UA.		New
10	Reinforced DC-link busbars for 50 mm components	6SL3162-2DB00-0AA.		New
11	Reinforced DC-link busbars for 100 mm components	6SL3162-2DD00-0AA.		New

Table A- 4 Hardware components available as of 11.2009

No.	Hardware component	Article number	Version	Revisions
1	Control Unit 320-2DP	6SL3040-1MA00-0AA1 Actual 2014: 6SL3040-1MA00-0AA0	4.3	New
2	TM120	6SL3055-0AA00-3KA0	4.3	New
3	SMC10 (30 mm wide)	6SL3055-0AA00-5AA3	4.3	New

A.3 Availability of hardware components

Table A- 5 Hardware components available as of 01.2011

No.	Hardware component	Article number	Version	Revisions
1	Control Unit 320-2PN	6SL3040-1MA01-0AA1 Actual 2014: 6SL3040-1MA01-0AA0	4.4	New
2	Braking Module booksize compact	6SL3100-1AE23-5AA0	4.4	New
3	SLM 55kW booksize	6SL3130-6TE25-5AA.	4.4	New
4	TM120 evaluation of up to four motor temperature sensors	6SL3055-0AA00-3KA.	4.4	New

Table A- 6 Hardware components available as of 04.2011

No.	Hardware component	Article number	Version	Revisions
1	S120 Combi three axes Power Module	6SL3111-3VE21-6FA0 6SL3111-3VE21-6EA0 6SL3111-3VE22-0HA0	4.4	New
2	S120 Combi four axes Power Module	6SL3111-4VE21-6FA0 6SL3111-4VE21-6EA0 6SL3111-4VE22-0HA0	4.4	New
3	S120 Booksize Compact power units Single Motor Module	6SL3420-1TE13-0AA0 6SL3420-1TE15-0AA0 6SL3420-1TE21-0AA0 6SL3420-1TE21-8AA0	4.4	New
4	S120 Booksize Compact power units Double Motor Module	6SL3420-2TE11-7AA0 6SL3420-2TE13-0AA0 6SL3420-2TE15-0AA0	4.4	New
5	Braking Module booksize	6SL3100-1AE31-0AB0	4.4	New

Table A- 7 Hardware components available as of 01.2012

No.	Hardware component	Article number	Version	Revisions
1	TM150 evaluation of up to 12 temperature sensors	6SL3055- 0AA0-3LA0	4.5	New
2	CU310-2 PN	6SL3040-1LA01-0AA0	4.5	New
3	CU310-2 DP	6SL3040-1LA00-0AA0	4.5	New

Table A- 8 Hardware components available as of Q4 2012

No.	Hardware component	Article number	Version	Revisions
1	Adapter Module 600	6SL3555-2BC10-0AA0	4.5	New

Table A- 9 Hardware components available as of 01.2013

No.	Hardware component	Article number	Version	Revisions
1	300% overload, booksize up to 18 A	6SL312.-.....-...4 for Motor Modules with 50 mm and: 3 A, 5 A, 9 A, 18 A, 2x3 A, 2x5 A, 2x9 A	4.6	New
2	SINAMICS S120M	6SL3532-6DF71-0R.. 6SL3540-6DF71-0R.. 6SL3542-6DF71-0R.. 6SL3562-6DF71-0R.. 6SL3563-6DF71-0R..	4.6	New

Table A- 10 Hardware components available as of 04.2014

No.	Hardware component	Article number	Version	Revisions
1	S120 Combi: New power unit	6SL3111-4VE21-0EA Four axis Power Modules with high amperage: 24 A, 12 A, 12 A, 12 A	4.7	New
2	Power Module PM240-2	6SL321.-.P.-..... FSA, FSB and FSC for 200 V and 400 V	4.7	New

Table A- 11 Hardware components available as of 04.2015

Nr	Hardware component	Article number	Version	Changes
1	TM31 Terminal Module	6SL3055-0AA00-3AA1	4.7 SP2	Revised
2	TM41 Terminal Module	6SL3055-0AA00-3PA1	4.7 SP2	Revised
3	DRIVE-CLiQ Hub Module DMC20	6SL3055-0AA00-6AA1	4.7 SP2	Revised

Table A- 12 Hardware components available as of 10.2015

Nr	Hardware component	Article number	Version	Changes
1	Motor Module with up to 2x overload (Booksize redesign)	6SL3120-1TE21-8AC. (18 A) 6SL3120-1TE23-0AC. (30 A) 6SL3120-2TE21-8AC. (2 x 18 A)	-	New
2	Motor Module with up to 3x overload (Booksize redesign)	6SL3120-1TE13-0AD. (3 A) 6SL3120-1TE15-0AD. (5 A) 6SL3120-1TE21-0AD. (9 A) 6SL3120-1TE21-8AD. (18 A) 6SL3120-1TE23-0AD. (30 A) 6SL3120-2TE13-0AD. (2 x 3 A) 6SL3120-2TE15-0AD. (2 x 5 A) 6SL3120-2TE21-0AD. (2 x 9 A) 6SL3120-2TE21-8AD. (2 x 18 A)	-	New
3	Motor plug connector with push-in connection	6SL3162-2MB00-0AC0	-	New
4	Motor plug connector with screw-type connection	6SL3162-2MA00-0AC0	-	New

Table A- 13 Hardware components available as of 07.2016

No.	Hardware component	Article number	Version	Changes
1	PM240-2 Power Module	6SL321.-.P.-. FSD, FSE and FSF for 200 V, 400 V and 690 V	4.8	New
2	TM31 Terminal Module	6SL3055-0AA00-3AA1	4.8	Revised
3	TM41 Terminal Module	6SL3055-0AA00-3PA1	4.8	Revised
4	TM54F Terminal Module	6SL3055-0AA00-3BA.	4.8	Revised
5	DMC20 DRIVE-CLiQ Hub Module	6SL3055-0AA00-6AA1	4.8	Revised
6	VSM10 Voltage Sensing Module	6SL3053-0AA00-3AA1	4.8	Revised

A.4 Availability of SW functions

Table A- 14 New functions, firmware 2.2

No.	SW function	SERVO	VECTOR	HW component
1	Technology controller	x	x	-
2	Two command data sets	-	x	-
3	Extended brake control	x	x	-
4	Automatic restart for vector and Smart Line Modules 5/10 kW	-	x	-
5	The ability to mix servo and vector V/f control modes on one CU	x	x	-
6	Regulated V_{dc} up to 480 V input voltage can be parameterized for Active Line Modules	x	x	-
7	Smart Mode for Active Line Modules booksize format	x	x	-
8	Extended setpoint channel can be activated	x	-	-
9	Evaluation, linear measuring systems	x	-	-
10	Synchronous motors 1FT6/1FK6/1FK7 with DRIVE-CLiQ resolver	x	-	-

Table A- 15 New functions, firmware 2.3

No.	SW function	SERVO	VECTOR	HW component
1	Motor data set changeover (eight motor data sets)	x	x	-
2	Buffer for faults/alarms	x	x	-
3	Rotor/pole position identification	x	x	-
4	Booting with partial topology, parking axis/encoder, deactivating/activating components	x	x	-
5	Friction characteristic with ten interpolation points, automatic characteristic plot	x	x	-
6	Utilization display	x	x	-
7	Evaluation of distance-coded zero marks for higher-level controllers	x	-	-
8	Vertical axes / electronic weight equalization for higher-level controllers	x	-	-
9	SIMATIC S7 OPs can be directly coupled	x	x	-
10	PROFIBUS NAMUR standard telegrams	-	x	-
11	Parallel connection	-	x	For chassis drive units
12	Edge modulation	x	x	For chassis drive units
13	Servo control type	x	-	Also chassis drive units
14	Terminal Module TM15 (DI/DO functionality)	x	x	-
15	1FN1, 1FN3 linear motors	x	-	-
16	1FW6 torque motors	x	-	-
17	1FE1 synchronous built-in motors	x	-	-
18	2SP1 synchronous spindles	x	-	-
19	1FU8 SIMOSYN motors	x	-	-
20	1FS6 explosion-protected motors	x	-	-
21	SME20/25 external Sensor Modules for incremental and absolute encoder evaluation	x	x	-

Table A- 16 New functions, firmware 2.4 or 2.4 SP1

No.	SW function	SERVO	VECTOR	HW component
1	SINAMICS S120 functionality for AC DRIVE (CU310 DP/PN)	x	x	-
2	Basic positioning	x	x	-
3	Encoder data set changeover (three EDS encoder data sets per drive data set)	x	x	-
4	Two command data sets (CDS)	x	x	-
5	Units changeover SI / US / %	x	x	-
6	Motor data identification servo	x	As of FW2.1	-
7	Increased torque accuracy for synchronous motors (kt estimator)	x	-	-

No.	SW function	SERVO	VECTOR	HW component
8	Hub functionality (hot-plugging, distributed encoder, star structure via DMC20)	x	x	-
9	Basic Operator Panel BOP20	x	x	-
10	Evaluation of SSI encoder (SMC30)	x	x	6SL3055-0AA00-5CA1
11	Pulse encoder emulation TM41	x	x	-
12	Automatic restart with Active Line Module	x	x	-
13	PROFIBUS extensions: – Slave-to-slave communication – Y link – Telegram 1 also for servo – Telegram 2, 3, 4 also for vector	x x x As of FW2.1	x x As of FW2.1 x	-
14	Safety Integrated Stop category 1 (SS1) with safety-related time	x	x	-
15	Measuring gearbox	x	x	-
16	Setting the pulse frequency grid in fine steps	x	x	-
17	Controller cycles that can be set	x	x	-
18	Possibility of mixing cycles on a DRIVE-CLiQ line	x	x	-
19	Clockwise/counter-clockwise bit (the same as changing the rotating field)	x	x	-
20	Sensor Module for 1FN, 1FW6 with protective separation (SME120/125)	x	-	-
21	Real-time stamps for alarms	x	x	CU320, 6SL3040-....- 0AA1 and Version C or higher (Actual 2014: 6SL3040-.....-0AA0)
22	Encoderless closed-loop speed control for torque motors	-	x	-
23	Separately excited synchronous motors with encoder	-	x	-
24	Drive converter/drive converter, drive converter/line supply (bypass) synchronizing	x	x	For chassis drive units
25	Voltage Sensing Module (VSM) for Active Line Module			Also for booksize drive units
26	Armature short-circuit braking, synchronous motors	x	-	-
27	CANopen extensions (vector, free process data access, profile DS301)	x	x	-
28	PROFINET IO communication with Option Module CBE20	x	x	-
29	New hardware components are supported (AC DRIVE, SME120/125, BOP20, DMC20, TM41)	x	x	-
30	Position tracking for torque motors (not for EPOS)	x	x	CU320, 6SL3040-....- 0AA1 and Version C or higher (Actual 2014: 6SL3040-.....-0AA0)
31	1FW3 torque motors	x	-	-

Table A- 17 New functions, firmware 2.5 or 2.5 SP1

No.	SW function	SERVO	VECTOR	HW component
1	<p>DCC (Drive Control Chart) with graphical interconnection editor (DCC-Editor):</p> <ul style="list-style-type: none"> Graphically configurable modules (logic, calculation and control functions) Module types that can be freely instantiated (flexible number of components/devices) Can be run on SIMOTION and SINAMICS controllers (DCC SINAMICS, DCC SIMOTION) 	x	x	-
2	<p>Safety Integrated Extended Functions:</p> <ul style="list-style-type: none"> Safety functionality integrated in the drive, controllable via PROFIsafe (PROFIBUS) or secure terminal module TM54F STO Safe Torque Off (previously Safe Standstill (SH)) SBC Safe Brake Control SS1 Safe Stop 1, STO after a delay time has expired, standstill without torque SOS Safe Operating Stop, safe standstill with full torque SS2 Safe Stop 2; SOS after a delay time has expired, standstill with full torque SLS Safely Limited Speed SSM Safe Speed Monitor, safe speed monitor feedback (n < nx) on a secure output <p>Note: The Safety Integrated Basic Functions STO and SBC have been implemented as of V2.1 and SS1 as of V2.4 (control via onboard terminals).</p>	x	x	<p>Safety Integrated Extended Functions only for:</p> <ul style="list-style-type: none"> Motor Modules (6SL3...-.....-0AA3) CUA31 (6SL3040-0PA00-0AA1)
3	<p>EPOS function extensions:</p> <ul style="list-style-type: none"> Traversing blocks / new task: "Travel to fixed stop" Traversing blocks / new continuation conditions: "External block relaying" Completion of position tracking for absolute encoder (load gear) Jerk limitation "Set reference point" also with intermediate stop (Traversing blocks and MDI) Reversing cam functionality also with reference run without reference cam 	x	x	-

No.	SW function	SERVO	VECTOR	HW component
4	Support of new motor series/types <ul style="list-style-type: none"> 1FT7 (synchronous servo motor) 1FN3 continuous load (linear motor for continuous load) 1PL6 (functionality released since V2.1, now available as list motor) 	x	1PL6 only	-
5	Support of new components <ul style="list-style-type: none"> Basic Line Module (BLM) in booksize format 	x	x	-
6	Support of new components <ul style="list-style-type: none"> Active Interface Module (AIM), booksize format TM54F (Terminal Module Failsafe) CUA32 (Control Unit Adapter for PM340) DRIVE-CLiQ encoder (machine encoder) 	x	x	-
7	Save data (motor and encoder data) from the Sensor Module on motor with DRIVE-CLiQ to memory card and load to "empty" Sensor Module	x	x	-
8	Evaluation of SSI encoders on AC Drive Controller CU310 (onboard interface)	x	x	Only for CU310 (6SL3040-0LA00-0AA1) (Actual 2014: discontinued)
9	Edge modulation (higher output voltages) in the vector control mode, also with booksize devices	-	x	Only for Motor Modules (6SL3...-.....-0AA3)
10	DC braking	x	x	-
11	Armature short-circuit: Internal	x	x	-
12	Armature short-circuit: Intermittent voltage protection	x	-	Only for Motor Modules (6SL3...-.....-0AA3)
13	Automatic firmware update for DRIVE-CLiQ components	x	x	-
14	Save STARTER project directly to memory card	x	x	-
15	The terminal area for booksize infeeds (BLM, SLM, ALM) can be parameterized to 230 V 3 AC	x	x	Only for infeeds in the booksize format (6SL3...-.....-0AA3)
16	Automatic speed controller setting	x	As of FW2.1	-
17	Technological pump functions	-	x	-
18	Simultaneous cyclical operation of PROFIBUS and PROFINET on CU320	x	x	-
19	Automatic restart also with servo	x	As of FW2.2	-
20	Operates at 500 µs PROFINET IO	x	-	-
21	Absolute position information (X_IST2) with resolver	x	x	-
22	DC link voltage monitoring depending on the line voltage	x	x	-
23	Automatic line frequency detection	x	x	-
24	Acceleration signal at the ramp-function generator output	x	x	-

No.	SW function	SERVO	VECTOR	HW component
25	Reset the drive device via parameter (p0972)	x	x	-
26	Alteration of the basic sampling time during the automatic read-justment of the sampling times depending on the number of drives on CU320 with vector (from 400 μ s to 500 μ s)	-	x	-
27	Dynamic energy management, extension of the Vdc_min, Vdc_max control	x	x	-
28	Endless trace	x	x	-
29	Extended PROFIBUS monitoring with timer and binector	x	x	-
30	Indexed actual value acquisition Simultaneous evaluation of multiple encoders	x	x	-

Table A- 18 New functions, firmware 2.6

No.	SW function	SERVO	VECTOR	HW component
1	Offset pulsing in the synchronous drive line-up	x	x	-
2	Safety Integrated Extended Functions: Internal armature short-circuit and integrated voltage protection	x	x	Safety Integrated Extended Functions only for: <ul style="list-style-type: none"> • Motor Modules (6SL3...-.....-...3) • CUA31 (6SL3040-0PA00-0AA1)
3	PROFIsafe via PROFINET	x	x	-
4	Pulse frequency wobbling	-	x	Motor Modules in chassis format: (6SL3...-.....-...3)
5	Position control load gear with multiple drive data sets (DDS)	x	x	-
6	Sensorless vector control (SLVC) New closed-loop control for passive loads	-	x	-
7	Variable signaling function	x	-	-
8	Quick magnetization for induction motors		x	-
9	Flux reduction for induction motors	x	-	-
10	Component status display	x	x	-
11	Downgrade lock	x	x	-
12	Parallel connection of motors	x	x	-
13	Parallel connection of Motor Modules	-	x	-
14	Parallel connection of power units	x	x	-
15	Master/slave function for Active Infeed	x	x	-
16	Thermal motor monitoring I2t model for synchronous motors	x	-	-
17	New PROFIdrive telegrams 116, 118, 220, 371	x	x	-
18	New RT classes for PROFINET IO	x	x	-
19	Use of bidirectional inputs/outputs on the CU	x	x	-
20	Autonomous operating mode for DRIVE-CLiQ components	x	x	-
21	Central signal for "ready for switching on" state on drive object	x	x	-
22	New motor series/types supported: 1FN6 continuous load (linear motor for continuous load operation)	x	-	-

Table A- 19 New functions, firmware 4.3

No.	SW function	SERVO	VECTOR	HW component
1	The 1FN6 motor series is supported	x	-	-
-2	DRIVE-CLiQ motors with star-delta changeover are supported	x	-	-
3	Referencing with several zero marks per revolution via the encoder interface	x	-	-
4	Permanent-magnet synchronous motors can be controlled down to zero speed without having to use an encoder	-	x	-
5	"SINAMICS Link": Direct communication between several SINAMICS S120	x	x	-
6	Safety Integrated: <ul style="list-style-type: none"> Control of the Basic Functions via PROFIsafe SLS without encoder for induction motors SBR without encoder for induction motors Own threshold value parameters for SBR: Up until now, SSM used parameter p9546 	x	x	-
7	Drive object encoder: An encoder can now be directly read-in via the encoder drive object and can then be evaluated by SIMOTION using the TO external encoder.	-	x	-
8	Support of new components <ul style="list-style-type: none"> CU320-2 TM120 	x	x	-
9	GSDML file expanded for Profisafe	x	x	-
10	USS protocol at interface X140	x	x	-
11	V/f diagnostics (p1317) permitted as regular operating mode	x	-	-
12	Setpoint-based utilization display, instead of the previous actual value-based utilization display	x	x	-
13	A performance license is required from the 4th axis (for servo/vector) or from the 7th U/f axis, instead of from a utilization of 50% and higher – which was the case up until now.	x	x	-
14	Tolerant encoder monitoring, 2nd part: <ul style="list-style-type: none"> Monitoring, tolerance band, pulse number Switchable edge evaluation for square-wave encoders Setting the zero speed measuring time for pulse encoder signal evaluation Changeover measuring procedure, actual value acquisition for square-wave encoder "LED check" encoder monitoring 	x	x	-

Table A- 20 New functions, firmware 4.4

No.	SW function	SERVO	VECTOR	HW component
1	Safety Integrated functions <ul style="list-style-type: none"> • SDI (Safe Direction) for induction motors (with and without encoder), for synchronous motors with encoder. • Supplementary condition for Safety without encoder (for induction motors): Only possible with devices in booksize and blocksize format. Not for devices in chassis format. 	x	x	-
2	Communication <ul style="list-style-type: none"> • PROFINET address can be written via parameter (e.g. when completely generating the project offline) • Shared device for SINAMICS S PROFINET modules: CU320-2 PN, CU310-2 PN 	x	x	-
3	Emergency retraction (ESR = Extended Stop and Retract)	x	x	-
4	TM41: Rounding for pulse encoder emulation (gear ratio; also resolver as encoder)	x	x	-
5	Further pulse frequencies for servo control and isochronous operation (3.2 / 5.33 / 6.4 kHz)	x	-	-
6	Chassis format: Current controller in 125 μ s for servo control for higher speeds (up to approx. 700 Hz output frequency)	x	-	-
7	Propagation of faults	x	x	-

Table A- 21 New functions, firmware 4.5

No.	SW function	SERVO	VECTOR	HW component
1	Support for new components, CU310-2	x	x	Refer to Appendix A1
2	Support for new components, TM150	x	x	-
3	Support for high-frequency spindles with pulse frequencies up to 32 kHz (a current controller cycle of 31.25 µs)	x	-	-
4	PROFINET: Support for the PROFInergy profile	x	x	-
5	PROFINET: Improved usability for Shared Device	x	x	-
6	PROFINET: Smallest selectable send cycle 250 µs	x	x	-
7	PROFINET: Bumpless media redundancy with CU310-2 PN, CU320-2 PN and CU320-2 with CBE20	x	x	-
8	Ethernet/IP communication extension via CBE20	x	x	-
9	SINAMICS Link: Smallest adjustable send clock 0.5 ms	x	x	-
10	Parameterization of SINAMICS Link connections without POWER ON	x	x	-
11	Write protection	x	x	-
12	Know-how protection	x	x	-
13	PMSM (old: PEM) encoderless up to n = 0 rpm	x	x	-
14	Decoupling of the pulse frequency from the current controller cycle, valid only for power units in the chassis format	-	x	-
15	Expansion of the number of process data words for infeeds up to 10 words for the send and receive directions	x	x	-
Safety Integrated functions				
16	CU310-2 safety functionality via terminals and PROFIsafe	x	x	-
17	Permanent activation of the speed limit and the safe direction of rotation without PROFIsafe or TM54F	x	x	-
18	Safely Limited Position (SLP)	x	x	-
19	Transfer of the Safely Limited Position via PROFIsafe	x	x	-
20	Variably adjustable SLS limit	x	x	-
21	New PROFIsafe telegrams 31, 901, 902	x	x	-

Table A- 22 New functions, firmware 4.6

No.	Software function	SERVO	VECTOR	Hardware component
1	Integrated Web server for SINAMICS Project and firmware download via Ethernet on the memory card Protection against power failure while updating via the Web server	x	x	-
2	Replacing a part with know-how protection: Encrypted loading into the file system	x	x	-
3	Parameterizable bandstop filters for Active Infeed control, chassis format	x	x	-
4	Current setpoint filter	x	-	-
5	Shortened rotating measurement	-	x	-
6	Redundant data backup on the memory card	x	x	-
7	Multiple trace	x	x	-
8	Brake control adaptation	x	x	-
9	Fast flying restart	-	x	-
10	Diagnostic alarms for PROFIBUS	x	x	-
11	DCC SINAMICS: Support of DCB libraries generated from the SINAMICS DCB Studio	x	x	-
12	SMC40 (EnDat 2.2)	x	x	-
13	CANopen expansions	x	x	-
14	Support of new components S120M	x	-	-
Safety Integrated functions				
15	Safety Integrated Extended functions with two TTL/HTL encoders	x	x	-
16	Safety: Safe Brake Test	x	x	-
17	Safety Info Channel	x	x	-

Table A- 23 New functions, firmware 4.7

No.	Software function	SERVO	VECTOR	Hardware component
1	Separately excited synchronous machine: New operating mode, only with HTL encoder and VSM	-	x	-
2	S120 Combi support	x	-	New power unit: 6SL3111-4VE21-0EA
3	Identification & Maintenance data sets (I&M 0...4) support	x	x	-
4	Isochronous support for IRT devices	-	x	-
5	Dynamic IP address assignment (DHCP) and temporary device names for PROFINET	x	x	-
6	Fast flying restart with voltage measurement	x	x	-
7	One button tuning	x	-	-
8	Online tuning	x	-	-
9	Adaptive current setpoint filter for online tuning	x	-	-
10	Independent setting of the pulse frequency and the PROFIBUS and PROFINET cycles	x	x	-
11	PROFenergy for SINAMICS S120	x	x	-
12	Activation of network functionality for booksize modules for renewable energies	x	x	-
13	New mode for ramp-function generator tracking with torque, power or current limit	-	x	-
Safety Integrated functions				
14	Parameterizable line contactor activation for STO	x	x	-
15	Extension of the safe gearbox switchover	x	x	-
16	Execute test stop automatically during ramp-up	x	x	-
17	Safety Integrated Extended Functions with two TTL/HTL encoders for booksize and blocksize	x	x	-
18	Uniform behavior for component replacement	x	x	-
19	SINAMICS S120 hydraulic drive with Safety Integrated	x	-	-

Table A- 24 New functions, firmware 4.8

No.	Software function	SERVO	VECTOR	Hardware component
1	Synchronous reluctance motors	-	x	-
2	Moment of inertia precontrol of the moment of inertia estimator	-	x	-
3	Expansion of the thermal motor models	x	x	-
4	Communication via MODBUS TCP	x	x	-
5	PROFINET system redundancy	x	x	
6	Expansion of SINAMICS Link functionality	x	x	-
7	Optimization of the web server functionality	x	x	-
8	Cogging torque compensation (under license)	x	-	-
9	Advanced Positioning Control (APC) (under license)	x	-	-
Safety Integrated functions				
10	SBR can now also be selected for SS1/SS2 with encoder	x	x	-
11	Basic Functions controllable via TM54F	x	x	-
12	Safe Stop 2 with external stop (SS2E)	x	x	-

A.5 Functions of SINAMICS S120 Combi

SINAMICS S120 Combi supports the following functions, which are described in this Function Manual (and in the Safety Integrated Function Manual). Any function not shown in this list is not available for SINAMICS S120 Combi

Table A- 25 Functional scope, SINAMICS S120 Combi

	SW function
Infeed	
	Smart Infeed
	Line contactor control
Servo control	
	Speed controller
	Speed setpoint filter
	Speed controller adaptation
	Torque-controlled operation
	Torque setpoint limitation
	Current controller
	Current setpoint filter
	Note about the electronic motor model
	V/f control for diagnostics
	Optimization of current and speed controller
	Encoderless operation
	Motor data identification (stationary/rotating measurement)
	Pole position identification
	Vdc control
	Dynamic Servo Control (DSC)
	Travel to fixed stop
	Vertical axis
Basic functions	
	Reference parameters/scaling
	OFF3 torque limits
	Simple brake control
	Runtime (operating hours counter)
	Component status display
	Parking axis and parking encoder
	Update of the firmware: Upgrade of firmware and project in STARTER, retrograde lock
Safety Integrated Basic Functions	
Safety Integrated Extended Functions (see SINAMICS S120 Safety Integrated Function Manual)	

Topology

Fixed DRIVE-CLiQ topology rules for SINAMICS S120 Combi. The device must always be connected according to the same principle.

System clocks

The sampling times are permanently set to 125 μ s for the following functions:

- Current controller
- Speed controller and
- Flux controller

The pulse frequency is permanently set to 4 kHz. This means that a maximum spindle speed of 24000 rpm can be reached.

Available motors

- Synchronous motors: 1FE1, 1FT6, 1FT7, 1FK7, 1FW6
- Induction motors: 1PH7, 1PH4, 1PL6, 1PH8

Index

A

- Absolute encoder
 - Adjusting, 484
- Absolute encoder adjustment, 458
- Acceptance test
 - SBC (Basic Functions), 694
 - SS1 (Basic Functions), 692
 - STO (Basic Functions), 691
- Access levels, 909
- Active Infeed
 - Bandstop filters, 36
 - Master/slave, 524
- Active Infeed Control, 26, 38
- Active Line Module, 25
- Active Mode, 28
- Actual speed value
 - Open, 215
- Actual speed value filter, 229
- Actual value acquisition
 - Indexed, 458
- Actual values
 - Parallel encoders, 458
- Additional closed-loop controls, 36, 556
- Address
 - License manager on the Internet, 1002
 - Setting the PROFIBUS address, 750
- Adjustable hardware filter, 350
- Adjusting
 - Absolute encoder, 484
- Advanced Position Control, 557
 - APC applied to master-slave axes, 585
 - APC with acceleration feedback, 573
 - APC with encoder combination and differential position feedback:, 568
 - APC with load velocity control, 580
 - APC without sensor on the load side, 562
 - Commissioning the function module, 560
 - Dependency on the parameter set, 584
 - Licensing, 561
 - Measuring frequency responses, 585
 - Measuring functions, 589
 - Parameter preassignment, 561
 - Setting the activation parameter, 583
 - Using the APC filter, 584
- ALM, 25
- Ambient temperature, 395

- Analog inputs
 - CU310-2, 935
 - Properties, 935
 - Signal processing, 935
- Analog outputs
 - Properties, 937
 - Signal processing, 937
- Analog setpoint
 - Communication, 520
- Anti-wind-up
 - DSC, 166
- APC, 557
 - Application examples, 587
- Application classes, 702
- ASCII code
 - Licensing, 1006
- Asynchronous pulse frequency, 269
- Automatic restart, 310
- Autotuning
 - Activating, 109
 - Current setpoint filter adaptation, 120
 - One button tuning, 109
 - Online tuning, 113
- Axis
 - Suspended, 173

B

- Bandstop filters
 - Active Infeed, 36
- Basic Functions
 - SBC, 654
 - SS1, 651
 - STO, 647
- Basic Infeed open-loop control, 46
- Basic Line Module, 25
 - Parallel connection, 530
 - Vdc_max controller, 47, 224, 286, 531
- Basic positioner, 474
- Basic positioning
 - Referencing, 484
- BICO technology, 920
 - Converter, 925
 - Fixed values, 925
 - Interconnecting signals, 922
- Bidirectional I/Os
 - Resource sharing, 934
- Binector, 920

- Bit pattern test, 667
- BLM, 25
- BOP20
 - Control word, drive, 953
- Brake control
 - Extended, 442
 - Simple, 335
- Braking Module External, 448
- Braking resistors
 - Braking Module activation threshold, 327
 - Braking resistor connection, 327
- Buffer protection
 - Chassis, 54
- Bypass
 - Vector control, 260

C

- Cam controllers, 470
- Certificate of License, 1002
- Chassis
 - Power units, 395
- Chip temperature, 395
- Closed-loop position control, 454
- Cogging torque compensation, 592
 - Activating, 592
 - Application examples, 596
 - Filling compensation tables, 594
- Combi, 1054
- Commissioning
 - Safety Integrated, 674
- Communication
 - Communication services, 876
 - Dynamic IP address assignment for PROFINET IO, 828
 - I&M, 826
 - Identification & Maintenance, 826
 - Used port numbers, 876
 - via Modbus TCP, 830
 - via PROFIBUS, 742
 - via PROFIdrive, 699
- Component replacement
 - Examples, 954, 954
- Connector, 921
- Controller setting, automatic
 - Servo control, 133
- Cooling unit, 450
- Copy protection
 - Activating, 1014
- Current controller (vector)
 - Current controller adaptation, 230
- Current distribution factor, 523

- Current setpoint, 523
- Current setpoint filter, 227
 - Servo, 97
- Current setpoint filter adaptation
 - Activating, 120
 - Adaptation with variable resonance frequencies, 124
 - Configuring, 120
 - Deactivating, 120
 - Effect, 122
 - Internal activation threshold, 123
 - Limit frequencies (upper/lower), 125
 - Online tuning active, 120
 - Range of movement of the filter, 123
 - Remedy for insufficient adaptation, 125
 - Stability of the speed control loop, 124
 - Start value of the adaptation, 124

D

- Data backup
 - Minimum requirements for a redundant data backup, 941
 - NVRAM, 938
 - Retentive, 940
- Data cross-check, 637
- Data reconstruction, 940
- Data set switchover, 914
- Data sets
 - Command data set (CDS), 910
 - Drive data set (DDS), 912
 - Encoder data set (EDS), 913
 - Motor data set (MDS), 914
- Data transfer
 - PROFINET, 779
- Datalogger, 344
- DC brake, 318
- DC braking
 - Activation as a response to a speed threshold, 320
 - Activation via parameters, 318
 - As fault response, 319
 - Deactivation via parameters, 319
 - OFF1/3, 320
 - Preconditions, 318
 - Setting as a response to a speed threshold, 320
 - Setting via parameters, 318
- DC braking after an OFF signal
 - Activating, 320
 - Setting, 320
- DC breaker, 519
- DCP flashing, 783

- DDS changeover, 914
 - With load gear position tracking, 464
 - Defective partition on memory card, 940
 - Derating function, 395
 - Determining the axis number, 728
 - Determining the object number, 728
 - Determinism, 776
 - Device identification, 751
 - Device name, 778
 - Diagnostic function
 - V/f control for servo control, 128
 - Diagnostics channel
 - Forwarding of messages, 772, 824
 - Diagnostics channels, 734
 - Digital inputs
 - Bidirectional, 932
 - Properties, 929
 - Signal processing, 929
 - Digital outputs
 - Bidirectional, 932
 - Properties, 931
 - Signal processing, 931
 - Direct setpoint specification (MDI), 511
 - Direction reversal, 308
 - Directives, 635
 - DME20, 901
 - Downgrade lock
 - For firmware, 392
 - Drive object, 918
 - Drive Object, 918
 - DRIVE-CLiQ
 - Check connections, 999
 - Diagnostics, 999
 - Emergency mode, 1000
 - Encoder, 485
 - Independent operation, 1000
 - Wiring rules, 972
 - DRIVE-CLiQ Hub
 - DMC20, 901
 - Droop, 213
 - DSC
 - Anti-wind-up, 166
 - dv/dt filter compact plus Voltage Peak Limiter, 305
 - dv/dt filter plus Voltage Peak Limiter, 304
 - Dynamic Servo Control, 163
 - Dynamic setpoint limiting, 163
- E**
- Edge evaluation of the zero mark, 351
 - EDS switchover, 914
 - Efficiency tuning
 - Vector control, 241
 - EIP, 848
 - Electronic rating plate, 958
 - Encoder
 - External, 165
 - Encoder dirty signal, 345
 - Encoder evaluation, 346
 - Encoder interface
 - Find reference mark, 710
 - Flying measurement, 712
 - Encoder range, 366
 - Encoder track monitoring, 348
 - Encrypted data transfer, 428
 - Encryption methods, 428
 - EPOS, 474
 - Direct setpoint specification (MDI), 511
 - Flying referencing, 489
 - Flying referencing using Safety Integrated functions, 500
 - Intermediate stop, 503, 512
 - Jog, 513
 - Limits, 478
 - Mechanical system, 478
 - Reject traversing task, 503, 512
 - Safe referencing, 498
 - Starting against a holding brake, 482
 - Traversing blocks, 501
 - ESR
 - Communication failure for Safety, 545
 - Generator operation, 545
 - Initiating ESR, 542
 - Overview, 540
 - Retraction, 544
 - Several axes, 545
 - Stopping, 543
 - Telegram extensions, 546
 - Unsuitable motors, 545
 - EtherNet/IP, 848
 - Commissioning the drive, 849
 - Connect the drive device, 848
 - Create generic I/O module, 848
 - Integrating the drive into an Ethernet network, 861
 - Make the communication settings, 850
 - Requirements, 850
 - Example
 - PROFIBUS telegram structure, 745
 - Expansion of the encoder evaluation, 355
 - Extended setpoint channel
 - Activation for servo control, 55
 - Extended Smart Mode, 42
 - Extended stopping and retraction (ESR), 540

- Extended torque control, 452
- External armature short-circuit braking
 - Activating, 315
 - Braking resistors calculate, 316
 - Example, 317
 - Setting, 315
- External braking resistors
 - Example, 316

F

- F01611
 - Fault value 1000, 666
- Faults and alarms
 - Forwarding, 927
 - Propagation, 927
- Filter
 - On/off test, 667
- Find reference mark, 710
- Firmware
 - Converting the project to new firmware, 390
 - Downgrade lock, 392
 - Protection against power failure while updating via the Web server, 392
 - Update, 390
 - Updating, 390
- Fixed setpoints, 60
- Fixed speed setpoints, 60
- Flying measurement, 712
- Flying referencing
 - EPOS, 489
- Flying restart, 247
 - Fast flying restart with voltage measurement, 251
 - Fast flying restart without voltage measurement, 250
 - for a reluctance motor, 251
 - For long cables, 249
- Following error monitoring
 - Dynamic, 470
- Forced dormant error detection (test stop)
 - Automatically when powering up, 643
 - Basic Functions, 642
 - Initiated by the application, 643
- Free telegrams, 705
- Freezing the speed raw value, 349
- Frequency setpoint
 - SMC30, 393
- Friction characteristic
 - Technology function, 333
- Function module, 433
 - Additional closed-loop controls, 36, 556
 - Basic positioner, 474

- Braking Module External, 448
 - Closed-loop position control, 454
 - Cogging torque compensation, 592
 - Cooling unit, 450
 - Extended brake control, 442
 - Extended monitoring functions, 440
 - Extended stopping and retraction (ESR), 540
 - Extended torque control, 452
 - Master/slave, 516
 - Moment of inertia estimator, 548
 - Parallel connection, 526
 - Technology controller, 435
- Functions
- Fixed speed setpoints, 60
 - Jog, 62
 - Motorized potentiometer, 58
 - Servo control, 77
 - Travel to fixed stop, 168
 - V/f control for servo control, 128

G

- Ground fault test, 296
- GSD
 - GSD file, 751

H

- Heat-sink temperature, 395
- Hot-plugging
 - DRIVE-CLiQ, 903
- HTTPS, 428

I

- I&M, 826
- I/f-controlled operation, 135
- Identification & Maintenance, 826
- IEC61000-2-4 standard, 28
- Independent operation, 1000
- Induction motors
 - DC brake, 318
- Infeed
 - 12-pulse, 529
 - Basic Infeed, 46
 - Pre-charging, 529
- Infeed concepts, 528
- Infeed units, 25
- Inputs/outputs
 - Overview, 928
- Interconnecting signals using BICO technology, 922

Interconnection using BICO technology, 922
 Intermediate stop
 EPOS, 503, 512
 Internal armature short-circuit, 650
 Internal armature short-circuit braking
 Activating, 314
 Deactivating, 314
 Setting, 314
 IO controller, 774
 IO device, 774
 IO supervisor, 774
 IRT, 786, 786, 787
 Comparison with RT, 788

J

Jerk limitation, 481
 Jog, 62
 EPOS, 513
 JOG
 Jog, 62

K

Key files, 428
 Kinetic buffering, 40, 222, 283
 Vdc control, 159
 Know-how protection
 Absolute know-how protection, 1014
 Activating, 1014
 Changing the password, 1018
 Copy protection, 1013
 Data security of the memory card, 1012
 Deactivating, 1017
 Executable functions, 1010
 For loading to the file system, 1020
 Locked functions, 1010
 Optional functions, 1011
 Overview, 1009
 Parameters that can be changed, 1011
 Password check, 1011
 Password security, 1009
 Restricted functions, 1011
 kT estimator
 Servo, 452

L

License key, 1002
 Create, 1004
 Display, 1004

 Entering in STARTER, 1005
 Entering with BOP20, 1006
 Licensing, 1002
 ASCII code, 1006
 Limits
 Torque setpoint, 91
 Line contactor control, 52
 Line Modules, 25
 Line supply and DC link identification, 524
 Load gear, 464
 LU, (Example)
 Length Unit, 454

M

Main/supplementary setpoint, 61
 Manufacturer-specific telegrams, 705
 Master/slave for Active Infeed
 Activation of the function, 524
 Current distribution factor, 523
 Description of the function module, 521
 Function diagram, 522
 Operating principle, 516
 Topology, 518
 VDC-link control band, 523
 Maximum acceleration, 479
 Maximum deceleration, 479
 Maximum velocity, 479
 MBAP, 837
 Measuring gearbox, 368
 Measuring time to evaluate zero speed, 356
 Media redundancy, 785
 Memory card, 940
 Minimum requirements for a redundant data backup, 941
 Minimum speed, 68
 Modbus Application Header, 837
 Modbus TCP, 830
 Activate via interface X1400, 833
 Activate via interface X150, 832
 Communication via data set 47, 841
 Function codes used, 837
 Mapping tables, 834
 Modbus register to the parameters of the Control Unit, 834
 Parameterizing communication for X1400, 833
 Parameterizing communication for X150, 832
 Read and write access, 837
 Reading and writing parameters, 840
 Modular machine concept, 297
 Moment of inertia estimator, 548
 Accelerated estimation, 554

- Commissioning, 552
- Load torque, 549
- Moment of inertia, 550
- Moment of inertia precontrol, 553
- Speed controller adaptation, 554
- Moment of inertia precontrol for vector control, 553
- Monitoring cycle, 637
- Monitoring functions
 - Extended, 440
- Monitoring, tolerance band, pulse number, 354
- Motion Control with PROFIBUS, 713
- Motor changeover, 895
- Motor data identification, 234
- Motor Modules
 - Derating, 395
 - Parallel connection, 526, 534
- Motor reactor, 302
- Motor temperature monitoring, 604
 - CU310-2, 627
 - CUA31/32, 627
 - Motor Module, 626
 - Motor with DRIVE-CLiQ, 628
 - Power Module, 626
 - Sensor Module, 612
 - SMC, 613
 - SMC10, 613
 - SMC20, 613
 - SMC30, 613
 - SMC40, 613
 - SME120/125, 614
 - Temperature sensor evaluation, 628
 - Terminal Modules, 616
 - Thermal motor model 1, 605
 - Thermal motor model 2, 607
 - TM120, 618
 - TM150, 620
 - TM31, 617
 - Wire break, short-circuit, 628
- Motorized potentiometer, 58
- Motors
 - Two-winding system, 535
- Multiturn encoder, 366

N

- Non-volatile memory, 938
- Number of controllable drives
 - Notes, 982
- Number of current controller cycles to generate the average value of the speed actual value, 356
- NVRAM, 938

O

- OFF3
 - Torque limits, 332
- On/off test, 667
- One button tuning
 - Configuring, 109
- Online tuning
 - Activating, 113
 - Configuring, 113
 - Deactivating, 113
- Open actual speed value, 215
- Operating hours counter, 338, 880
- Operating temperature, 395
- Operation without an encoder
 - Servo control, 135
- Output current
 - Power units, 395

P

- Parallel connection
 - Basic Line Modules, 530
 - Motor Modules, 526, 534
- Parameter
 - Categories, 907
 - Reset, 909
 - Save retentively, 909
 - Types, 907
- Parameter list
 - Creating in the Web server, 419
 - Deleting in the Web server, 422
- Parameterizing with BOP, 942
- Password
 - Changing, 1018
- Ping snap, 880
- PN Gate, 798
 - Development kit, 801
 - Requirements, 800
 - Transferred functions, 799
- Pole position adaptation, 352
- Pole position identification
 - Servo, 151
- Position controller, 468
 - Monitoring functions, 470
- Position tracking, 368, 464
 - Load gear, 459
 - Measuring gearbox, 366
- Positioning monitoring, 470
- Power Modules
 - Derating, 395

- Power unit
 - Overload, 395
 - Precharging contactor
 - Chassis, 54
 - Precontrol
 - Speed, 209
 - Private key, 428
 - Probe evaluation, 176
 - Example, 182
 - Handshake, 176
 - More than two edges, 179
 - Time-critical data transfer, 177
 - With handshake, 177, 178
 - Without handshake, 178
 - Process data, 707
 - Process data, control words
 - A_DIGITAL, 702
 - G1_STW, 702
 - G2_STW, 702
 - G3_STW, 702
 - MT_STW, 702
 - STW1, 702
 - STW2, 702
 - Process data, setpoints
 - KPC, 702
 - MOMRED, 702
 - NSET_A, 702
 - NSET_B, 702
 - XERR, 702
 - PROFIBUS, 742
 - Device identification, 751
 - Diagnostics, 737
 - Forwarding of messages via diagnostics channels, 772
 - Generic station description file, 751
 - Interface Mode, 709
 - Master class 1 and 2, 743
 - Motion Control with PROFIBUS, 713
 - Setting the address, 750
 - Sign-of-life, 760, 796
 - Slave-to-slave communication, 520, 761
 - Telegrams, 705
 - Terminating resistor, 752
 - VIK-NAMUR, 751
 - PROFIBUS diagnostics data, 737
 - Channel-related diagnostics, 740
 - Data sets DS0/DS1 and diagnostics alarm, 741
 - Identifier-related diagnostics, 738
 - Standard diagnostics, 738
 - Status messages/module status, 739
 - PROFIBUS telegram structure, 745
 - PROFIdrive, 699
 - Controller, Supervisor, Drive Unit, 700
 - Device classes, 699
 - Message classes, 734
 - Message classes for PROFINET, 735
 - PROFIBUS message classes, 737
 - Reading parameters, 728
 - Telegrams, 705
 - Write parameter, 731
 - PROFInergy, 817
 - Access point, 817
 - Certification, 817
 - Commands, 820
 - PROFINET
 - Connection channels, 780
 - Data transfer, 779
 - Diagnostics, 735
 - Forwarding of messages via diagnostics channels, 824
 - Interface, 782
 - Structure example of a system redundancy, 815
 - System redundancy, 814
 - With two controllers, 802
 - PROFINET Gate, 798
 - PROFINET IO, 774
 - Addresses, 777
 - IRT, 786
 - With IRT, 776
 - With RT, 776
 - Propagation type, 927
 - Protection against power failure
 - When updating the firmware via the Web server, 392
 - Public certificate, 428
 - Pulse frequency, 395
 - Setting, 969
 - Pulse frequency wobbling, 307
 - Pulse number correction for faults, 353
 - Pulse/direction interface, 393
- ## R
- Ramp-down generator
 - Scaling, 72
 - Ramp-function generator
 - Scaling, 72
 - Ramp-function generator, extended, 70
 - Ramp-up with partial topology, 297, 979
 - Rating plate
 - Control Unit, 941
 - Solid-state, 958
 - Real-time communication, 776

- Redundancy
 - Power unit, 258
- Reference model, 209
- Reference variables
 - Disabling, 291
 - Protecting, 291
- Referencing
 - Basic positioning, 484
- Reluctance motor, 201, 251
- Reset
 - Parameter, 909
- RESM, 201
- Response times, 658
 - Basic Functions via PROFIsafe (CU310-2 and CU320-2), 660
 - Basic Functions via terminals on the Control Unit and the Motor Module, 659
 - Basic Functions via TM54F, 661
- Ring topology, 785
 - Scalance, 785
- Rotating measurement (shortened) for vector control, 239
- Rotating measurement for vector control, 237
- RT
 - Comparison with IRT, 788
- RT classes
 - Send cycles, 790
 - Setting, 788
 - Update cycles, 790
- S**
- S120 Combi, 1054
- Safe Brake Adapter
 - Chassis format, 656
- Safe Brake Control
 - Chassis format, 656
 - SBC, 654
- Safe Stop 1
 - Basic Functions, 651
 - SS1, 651
 - Time-controlled, 651
 - With OFF3 (Basic Functions), 651
- Safe Torque Off
 - Basic Functions, 647
 - STO, 647
- Safety Integrated, 640
 - Commissioning, 674
 - Component replacement, 675
 - Password, 641
 - Series commissioning, 675
- Safety Integrated Basic Functions
 - Stop responses, 679
- Safety Integrated password, 641
- Safety logbook, 687
- Sampling times, 960
 - Setting, 970
- Save (retentively)
 - Parameter, 909
- SBA, 656
- SBC
 - Acceptance test, 694
 - Basic Functions, 654
 - Safe Brake Control, 654
- Secure Socket Layer, 428
- Security certificates
 - Web server, 428, 430, 431
- Sequence of objects in the telegram, 744, 779
- Servo control, 77
 - Activating the extended setpoint channel function module, 55
 - Automatic controller setting for the speed controller, 133
 - Comparison with vector control, 78, 188
 - Current controller, 105
 - Encoderless operation, 135
 - Properties, 78, 188
 - Speed controller, 85
 - Torque setpoint, 91
 - Torque-controlled operation, 88
 - Travel to fixed stop, 168
 - Tuning, 133
 - V/f control, 128
 - Vdc control, 159
- Servo current controller
 - Current and torque limitation, 105
 - Current control, 105
 - Current controller adaptation, 105
- Setpoint addition
 - Servo, 81
- Setpoint channel, 55
 - Direction of rotation limiting, 67
 - Direction reversal, 67
 - Extended, 56
 - Fixed speed setpoints, 60
 - Jog, 62
 - Main/supplementary setpoint, 61
 - Motorized potentiometer, 58
 - Ramp-function generator, extended, 70
 - Setpoint limitation, 68
 - Setpoint modification, 61
 - Skip frequency bands, 68
- Setpoint modification, 61

- Setpoint sources, 57
 - Setting the fault responses, 321
 - Shared device, 802
 - Short-circuit test, 296
 - SINAMICS Link
 - Activation, 871
 - Bus cycle, 865
 - Configuration example, 871
 - Configuring, 867
 - Requirements, 863
 - Synchronous cycle, 865
 - Transmission time, 864
 - SINAMICS S120 Combi, 1054
 - Sine-wave filter, 300
 - Singleturn encoder, 366
 - Slave-to-slave communication
 - Faults, 771
 - PROFIBUS, 761
 - Setting in HW Config, 765
 - Sliding averaging of the speed actual value, 356
 - Slip compensation, 281
 - SLM, 25
 - Smart Infeed Control, 39
 - Smart Line Module, 25
 - Smart Mode, 28
 - SMC30
 - Frequency setpoint, 393
 - Software limit switch, 480
 - Speed controller, 203
 - Free Kp_n/Tn_n adaptation, 206
 - Limits, 85
 - Properties, 85
 - Reference model, 209
 - Speed controller adaptation, 86
 - Speed controller precontrol, 209
 - Speed setpoint filter, 83
 - Speed-dependent Kp_n/Tn_n adaptation, 206
 - Speed limitation
 - Droop, 213
 - Speed raw value
 - Freezing, 349
 - Speed setpoint filter
 - Servo, 83
 - SS1
 - Acceptance test (Basic Functions), 692
 - Basic Functions, 651
 - Safe Stop 1, 651
 - Safe Stop 1 (Basic Functions), 651
 - With external stop (Basic Functions), 653
 - With OFF3 (Basic Functions), 651
 - SS1E, 653
 - SS1 with external stop (Basic Functions), 653
 - Standard telegrams, 705
 - Standards, 635
 - Standstill measurement
 - Motor data identification, 234
 - Step-up factor, 30
 - STO
 - Basic Functions, 647
 - Safe Torque Off (Basic Functions), 647
 - STOP A, 679
 - Stop cam, 480
 - STOP F, 679
 - Stop response
 - STOP A, 679
 - STOP F, 679
 - Switches for PROFIBUS address, 750
 - Switching operation
 - Timing, 666
 - Switchover
 - Fixed speed setpoints, 60
 - Synchronization (vector control), 253
 - Synchronization domain, 789
 - Synchronization, ping snap, 880
 - System redundancy, 814
 - Configuring, 815
 - Diagnostics LEDs, 816
 - Example, 815
 - System runtime, 338
 - System sampling times, 960
 - CU31/CU32, 988
 - DCC, 987
 - EPOS, 987
 - Mixed operation, 986
 - Servo control, 982
 - V/f control, 986
 - Vector control, 984
- ## T
- Technology controller, 435
 - Technology function
 - Friction characteristic, 333
 - Telegrams
 - Manufacturer-specific, 705
 - Sequence of objects, 744, 779
 - Standard, 705
 - Structure, 707
 - Terminal Module 41
 - Commissioning, 382
 - Example, 382
 - Limit frequencies, 381
 - SIMOTION mode, 374

- SINAMICS mode, 375
 - Zero mark synchronization, 380
- Test of switch-off signal paths, 642
- Test pulse evaluation, 296
- Thermal motor monitoring
 - Thermal motor models, 604
- Three-winding transformer, 519
- Time stamp, 880
- Time synchronization, 880
- TM120, 618
- TM150
 - Forming groups, 623
 - Sensor failure, 624
 - Temperature sensor types, 621
- TM31, 617
- TM41, 374
 - Referencing modes, 377
 - SIMOTION mode, 374
 - SINAMICS mode, 375
 - Zero mark emulation, 377
- Tolerant encoder monitoring, 346
- Topology, parallel connection with an auxiliary drive, 537
- Torque control, 217
 - Extended, 452
- Torque limiting, 220
- Torque limits
 - OFF3, 332
- Torque setpoint, 91
- Torque-controlled operation, 88
- Travel to fixed stop, 168
- Traversing blocks, 501
- Traversing task
 - Rejecting, 502, 512
- Two-channel brake control, 655
- Type of connection, 817

U

- Underlicensing, 1002
- Unit changeover, 289
- Update of the backup copy, 940

V

- V/f control, 273
 - Servo control, 128
 - Slip compensation, 281
 - Vdc control, 283
- Vdc control
 - Servo control, 159

- V/f control, 283
 - Vector n/m control, 222
- Vdc_max control
 - Vector n/m control, 224
- Vdc_min control
 - Servo, 160
 - Vector n/m control, 223
 - Vector V/f control, 285
- Vector control
 - Actual speed value filter, 229
 - Automatic restart, 310
 - Bypass, 260
 - Comparison with servo control, 78, 188
 - Current setpoint filter, 227
 - Motor data identification, 232, 234
 - Properties, 78, 188
 - Rotating measurement, 232, 237
 - Shortened rotating measurement, 239
 - Speed controller adaptation, 206
 - Torque control, 217
 - Torque limiting, 220
 - Torque setpoint, 192
 - With encoder, 200
 - Without speed encoder, 191
- Vector drives
 - Voltage Sensing Module, 255
- Voltage boost
 - Servo, 131
 - Vector, 277
- Voltage Sensing Module, 28
- VSM
 - Commissioning, 255
 - Identification via LED, 256
 - Vector drives, 255
- VSM10, 28

W

- WEB License Manager, 1002
- Web server, 399
 - Access protection, 406, 407
 - Access rights, 399
 - Access rights for parameter lists, 409
 - Activating, 401
 - Addressing, 400
 - Changing drive parameters, 424
 - Changing parameter values, 424
 - Configuration, 399, 401
 - Creating a parameter list, 419
 - Data transfer, 399
 - Deactivating, 401
 - Default settings, 401

- Deleting a parameter list, 422
- Deleting list entries of the parameter list, 422
- Displaying device information, 414
- Displaying faults and alarms of the drive, 418
- Displaying the diagnostic buffer, 417
- DO status and operating display, 415
- Interfaces, 400
- Login, 410
- Logout, 410
- Password protection, 403
- Protection against power failure during the firmware update, 392
- Read access, 403
- Restoring last firmware, 387
- Secure connection, 401
- Secure data transfer, 428
- Security certificates, 428
- Security certificates from a certification authority, 431
- Start, 410
- Start page, 410
- Status of the drive objects, 415
- Supported Internet browsers, 400
- Updating the firmware, 387
- Using security certificates in the default configuration, 430
- Write access, 403
- Wiring rules
 - DRIVE-CLiQ, 972
- Write protection
 - Activating, 1007
 - Deactivating, 1009
 - Overview, 1007

Z

- Zero mark tolerance, 349

Siemens AG
Digital Factory
Motion Control
Postfach 3180
91050 ERLANGEN
GERMANY

Subject to change

www.siemens.com/motioncontrol