

SIEMENS

SINAMICS

SINAMICS S110

Manual

Edition

07/2015

Answers for industry.

SIEMENS

SINAMICS

S110 SINAMICS S110

Manual

Preface

Fundamental safety instructions 1

System overview 2

Mains connection and line-side power components 3

Blocksize Power Modules (PM240-2) 4

DC link components 5

Power components on the motor side 6

CU305 Control Units 7

Supplementary system components and encoder system integration 8

Accessories 9

Cabinet design and EMC for components, Blocksize format 10

Service and maintenance 11

Annex A

Legal information

Warning notice system

This manual contains notices you have to observe in order to ensure your personal safety, as well as to prevent damage to property. The notices referring to your personal safety are highlighted in the manual by a safety alert symbol, notices referring only to property damage have no safety alert symbol. These notices shown below are graded according to the degree of danger.

 DANGER
indicates that death or severe personal injury will result if proper precautions are not taken.

 WARNING
indicates that death or severe personal injury may result if proper precautions are not taken.

 CAUTION
indicates that minor personal injury can result if proper precautions are not taken.

NOTICE
indicates that property damage can result if proper precautions are not taken.

If more than one degree of danger is present, the warning notice representing the highest degree of danger will be used. A notice warning of injury to persons with a safety alert symbol may also include a warning relating to property damage.

Qualified Personnel

The product/system described in this documentation may be operated only by **personnel qualified** for the specific task in accordance with the relevant documentation, in particular its warning notices and safety instructions. Qualified personnel are those who, based on their training and experience, are capable of identifying risks and avoiding potential hazards when working with these products/systems.

Proper use of Siemens products

Note the following:

 WARNING
Siemens products may only be used for the applications described in the catalog and in the relevant technical documentation. If products and components from other manufacturers are used, these must be recommended or approved by Siemens. Proper transport, storage, installation, assembly, commissioning, operation and maintenance are required to ensure that the products operate safely and without any problems. The permissible ambient conditions must be complied with. The information in the relevant documentation must be observed.

Trademarks

All names identified by ® are registered trademarks of Siemens AG. The remaining trademarks in this publication may be trademarks whose use by third parties for their own purposes could violate the rights of the owner.

Disclaimer of Liability

We have reviewed the contents of this publication to ensure consistency with the hardware and software described. Since variance cannot be precluded entirely, we cannot guarantee full consistency. However, the information in this publication is reviewed regularly and any necessary corrections are included in subsequent editions.

Preface

SINAMICS documentation

The SINAMICS documentation is organized in the following categories:

- General documentation/catalogs
- User documentation
- Manufacturer/service documentation

Additional information

You can find information on the following topics at the following address (<http://w3.siemens.com/mcms/mc-solutions/en/motion-control/support/technical-documentation/Pages/technical-documentation.aspx>):

- Ordering documentation/overview of documentation
- Additional links to download documents
- Using documentation online (find and search in manuals/information)

Please send any questions about the technical documentation (e.g. suggestions for improvement, corrections) to the following e-mail address (<mailto:docu.motioncontrol@siemens.com>).

My Documentation Manager

At the following address (<http://www.siemens.com/mdm>), you can find information on how to create your own individual documentation based on Siemens' content, and adapt it for your own machine documentation.

Training

At the following address (<http://www.siemens.com/sitrain>), you can find information about SITRAIN (Siemens training on products, systems and solutions for automation and drives).

FAQs

You can find Frequently Asked Questions in the Service&Support pages under Product Support (<https://support.industry.siemens.com/cs/de/en/ps/faq>).

SINAMICS

You can find information about SINAMICS at the following address (<http://www.siemens.com/sinamics>).

Usage phases and their documents/tools (as an example)

Table 1 Usage phase and the available tools / documents

Usage phase	Tools/documents
Orientation	SINAMICS S Sales Documentation
Planning/configuration	SIZER configuration tool Configuration Manuals, Motors
Deciding/ordering	SINAMICS S Catalogs
Installation/assembly	<ul style="list-style-type: none"> • SINAMICS S110 Manual
Commissioning	<ul style="list-style-type: none"> • STARTER commissioning tool • SINAMICS S110 Getting Started • SINAMICS S110 Function Manual Drive Functions • SINAMICS S110 List Manual
Usage/operation	<ul style="list-style-type: none"> • SINAMICS S110 Function Manual Drive Functions • SINAMICS S110 List Manual
Maintenance/servicing	<ul style="list-style-type: none"> • SINAMICS S110 Function Manual Drive Functions • SINAMICS S110 List Manual • SINAMICS S110 Manual

Target group

This documentation is intended for machine manufacturers, commissioning engineers, and service personnel who use the SINAMICS drive system.

Benefits

This manual provides all of the information, procedures and operator actions required for the particular usage phase.

Standard scope

The scope of the functionality described in this document can differ from that of the drive system that is actually supplied.

- Other functions not described in this documentation might be able to be executed in the drive system. However, no claim can be made regarding the availability of these functions when the equipment is first supplied or in the event of service.
- The documentation can also contain descriptions of functions that are not available in a particular product version of the drive system. The functionality of the supplied drive system should only be taken from the ordering documentation.
- Extensions or changes made by the machine manufacturer must be documented by the machine manufacturer.

For reasons of clarity, this documentation does not contain all of the detailed information on all of the product types, and cannot take into consideration every conceivable type of installation, operation and service/maintenance.

Technical Support

Country-specific telephone numbers for technical support are provided in the Internet at the following address (<https://support.industry.siemens.com/sc/ww/en/sc/2090>) in the "Contact" area.

EC Declaration of Conformity, certificates, certifications, manufacturers declarations

You can find the EC Declaration of Conformity for the relevant directives as well as the relevant certificates, prototype test certificates, manufacturers declarations and test certificates for functions relating to functional safety ("Safety Integrated") in the Internet at the following address (<https://support.industry.siemens.com/cs/ww/en/ps/13231/cert>).

You can obtain an up-to-date list of currently certified components on request from your local Siemens office. If you have any questions relating to certifications that have not yet been completed, please ask your Siemens contact person.

Note

You can find certificates for the North American market on the Internet page of the certifier:

- For products with UL certificate (<http://database.ul.com/cgi-bin/XYV/template/LISEXT/1FRAME/index.html>)
 - For products with TÜV SÜD certificate (https://www.tuev-sued.de/industry_and_consumer_products/certificates)
 - For products with CSA certificate (<http://www.csagroup.org/de/en/services/testing-and-certification/certified-product-listing>)
-

Low-Voltage Directive

When operated in dry areas, SINAMICS S units conform to the Low-Voltage Directive 2006/95/EC.

EMC directive

SINAMICS S devices fulfill EMC Directive 89/336/EEC or 2014/130/EEC in the configuration specified in the associated EC Declaration of Conformity for EMC and when the Configuration Manual EMC Installation Guideline, article number 6FC5297-0AD30-0□P□, is implemented.

EMC limit values in South Korea

이 기기는 업무용(A급) 전자파적합기기로서 판매자 또는 사용자는 이 점을 주의하시기 바라며, 가정외의 지역에서 사용하는 것을 목적으로 합니다.
 For sellers or other users, please bear in mind that this device is an A-grade electromagnetic wave device. This device is intended to be used in areas other than at home.

The EMC limit values to be observed for Korea correspond to the limit values of the EMC product standard for variable-speed electric drives EN 61800-3 of category C2 or the limit value class A, Group 1 to CISPR11. By implementing appropriate additional measures, the limit values according to category C2 or limit value class A, Group 1, are observed. Further, additional measures may be required, such as using an additional radio interference suppression filter (EMC filter).

The measures for EMC-compliant design of the system are described in detail in this manual respectively in the EMC Installation Guideline Configuration Manual.

The final statement regarding compliance with the standard is given by the respective label attached to the individual unit.

Ensuring reliable operation

The manual describes a desired state which, if maintained, ensures the required level of operational reliability and compliance with EMC limit values.



Should there be any deviation from the requirements in the manual, appropriate actions (e.g. measurements) must be taken to check/prove that the required level of operational reliability and compliance with EMC limit values are ensured.

Spare parts

Spare parts are available on the Internet at the following address (<https://support.industry.siemens.com/sc/ww/en/sc/2110>).

Ground symbols

Table 2 Symbols

Symbol	Meaning
	Connection for protective conductor (PE)
	Ground (e.g. M 24 V)
	Connection for function potential bonding

Testing the protection against electric shock when using frequency converters

Protection on indirect contact in the motor circuit of a converter and automatic disconnection in case of a fault in accordance with DIN EN 60364-4-41 VDE 0100, part 410 is ensured if the following conditions are met:

- The installation instructions provided in the documentation of the converter have been followed, in particular, regarding
 - Equipotential bonding
 - Conductor cross section
 - Fuse protection
- The valid standards were complied with during installation:
 - DIN EN 50178 VDE 0160
 - DIN EN 60204-1 VDE 0113, part 1
 - DIN EN 60364-5-52 VDE 0100-520
 - DIN EN 60364-5-54 VDE 0100-540
- Continuity of the PE conductor is ensured according to DIN VDE 0100-600 (IEC 60364-6)

Converters of the SINAMICS series meet the requirements defined in DIN EN 60364-4-41 VDE 0100, part 410 and comply with the specified break times.

Background

In the case of a short-circuit with negligible impedance to ground, the converter interrupts the circuit within the shortest time ($\ll 100$ ms). As a consequence, there is very high impedance between the converter DC link and the output (> 1 M Ω) so that the possible voltage as result of the voltage divider with the impedance of the ground connection between the motor and converter is less than 50 VAC or 120 VDC.

Table of contents

	Preface	5
1	Fundamental safety instructions	17
1.1	General safety instructions	17
1.2	Safety instructions for electromagnetic fields (EMF)	21
1.3	Handling electrostatic sensitive devices (ESD)	21
1.4	Industrial security	22
1.5	Residual risks of power drive systems.....	23
2	System overview.....	25
2.1	Field of application	25
2.2	Platform Concept and Totally Integrated Automation	26
2.3	Overview of SINAMICS S110	28
2.4	System data	29
2.5	Derating	31
3	Mains connection and line-side power components	35
3.1	Introduction	35
3.2	Information on the disconnecter unit.....	36
3.3	Overcurrent protection by means of line fuses and circuit breakers	36
3.4	Using residual-current devices	40
3.5	Overvoltage protection.....	41
3.6	Line contactors.....	42
3.7	Line filter	43
3.7.1	Description	43
3.7.2	Safety instructions for line filters	43
3.7.3	Classification of EMC behavior	44
3.7.4	Electromagnetic compatibility (EMC) of the system	46
3.7.5	Dimension drawings.....	47
3.7.6	Mounting	50
3.7.7	Technical data.....	51
3.8	Line reactors	52
3.8.1	Description	52
3.8.2	Safety instructions for line reactors.....	52
3.8.3	Dimension drawings.....	54
3.8.4	Mounting	55
3.8.5	Electrical Connection	56
3.8.6	Technical data.....	57

3.9	Line connection variants	58
3.9.1	Operation on different line system configurations.....	58
3.9.2	Methods of line connection	61
3.9.3	Operation of the line connection components on the supply line	63
3.9.4	Operation of the line connection components via an autotransformer	64
3.9.5	Operation of the line connection components via an isolating transformer.....	65
4	Blocksize Power Modules (PM240-2)	67
4.1	Description	67
4.2	Safety instructions for Blocksize Power Modules (PM240-2)	70
4.3	Interface description.....	73
4.3.1	Overview	73
4.3.2	Connection example	77
4.3.3	Line supply connection	78
4.3.4	Motor connection.....	79
4.3.5	Braking resistor and DC link connection	80
4.3.6	Safe Brake Relay connection.....	81
4.3.7	STO connection via PM terminals.....	82
4.4	Dimension drawings.....	83
4.4.1	Dimension drawings PM240-2	83
4.4.2	Drilling patterns	91
4.5	Mounting	93
4.5.1	Mounting instructions	93
4.5.2	Mounting dimensions and tightening torques	94
4.5.3	Mounting the shield connection plate	95
4.6	Technical data.....	96
4.6.1	Note about degree of protection	96
4.6.2	200 V Power Modules.....	97
4.6.3	400 V Power Modules.....	100
4.6.4	Characteristics	106
5	DC link components.....	109
5.1	DC link fuses	109
5.2	Braking resistors	109
5.2.1	Description	109
5.2.2	Safety instructions for blocksize braking resistors	110
5.2.3	Connection examples	111
5.2.4	Dimension drawings.....	112
5.2.5	Installation	115
5.2.6	Technical data.....	116
6	Power components on the motor side	119
6.1	Motor reactors	119
6.1.1	Description	119
6.1.2	Safety instructions for motor reactors	119
6.1.3	Dimension drawings.....	121
6.1.4	Mounting	125
6.1.5	Electrical connection	126
6.1.6	Technical data.....	127

7	CU305 Control Units	129
7.1	Description	129
7.2	Safety instructions for Control Unit CU305	130
7.3	Interface description	132
7.3.1	General interface overview	132
7.3.2	CU305 PN (PROFINET)	133
7.3.2.1	Overview	133
7.3.2.2	X150 P1 / P2 PROFINET	134
7.3.3	CU305 DP (PROFIBUS)	135
7.3.3.1	Overview	135
7.3.3.2	X126 PROFIBUS/USS interface	136
7.3.3.3	PROFIBUS/USS address switch	136
7.3.4	CU305 CAN	138
7.3.4.1	Overview	138
7.3.4.2	X126 CAN interface	139
7.3.4.3	S100 DIP switch	139
7.3.5	Identical interfaces for CU305 PN / DP / CAN	140
7.3.5.1	X22 serial interface (RS232)	140
7.3.5.2	X23 HTL/TTL/SSI encoder interface	140
7.3.5.3	Pulse/direction interface	144
7.3.5.4	X100 DRIVE-CLiQ interface	146
7.3.5.5	X124 Electronics power supply	146
7.3.5.6	X130 fail-safe digital inputs	147
7.3.5.7	X131 fail-safe digital inputs/outputs	148
7.3.5.8	X132 digital inputs/outputs, analog input	149
7.3.5.9	X133 digital inputs/temperature sensor input	150
7.3.5.10	X520/X521/X522 test sockets	151
7.3.5.11	Slot for the memory card	152
7.4	Connection examples	154
7.5	Meaning of LEDs	157
7.5.1	Reaction of the LEDs during power up	158
7.5.2	Behavior of the LEDs in the operating state	159
7.6	Dimension drawings	161
7.6.1	Dimension drawing, CU305 PN	161
7.6.2	Dimension drawing CU305 DP/CAN	162
7.7	Installation	163
7.8	Technical data	164
8	Supplementary system components and encoder system integration	165
8.1	Basic Operator Panel BOP20	165
8.1.1	Description	165
8.1.2	Interface description	165
8.1.3	Installation	168
8.2	Sensor Module Cabinet-Mounted SMC10	170
8.2.1	Description	170
8.2.2	Safety instructions for Sensor Modules Cabinet-Mounted	170
8.2.3	Interface description	172
8.2.3.1	Overview	172

8.2.3.2	X500 DRIVE-CLiQ interface	173
8.2.3.3	X520 encoder system interface	174
8.2.3.4	X524 Electronics power supply	175
8.2.4	Meaning of the LED	176
8.2.5	Dimension drawing	177
8.2.6	Mounting	178
8.2.7	Technical data	179
8.3	Sensor Module Cabinet-Mounted SMC20	181
8.3.1	Description	181
8.3.2	Safety instructions for Sensor Modules Cabinet-Mounted	181
8.3.3	Interface description	182
8.3.3.1	Overview	182
8.3.3.2	X500 DRIVE-CLiQ interface	183
8.3.3.3	X520 encoder system interface	184
8.3.3.4	X524 Electronics power supply	185
8.3.4	Meaning of the LED	186
8.3.5	Dimension drawing	187
8.3.6	Mounting	188
8.3.7	Technical data	189
8.4	Sensor Module Cabinet-Mounted SMC30	190
8.4.1	Description	190
8.4.2	Safety instructions for Sensor Modules Cabinet-Mounted	190
8.4.3	Interface description	191
8.4.3.1	Overview	191
8.4.3.2	X500 DRIVE-CLiQ interface	192
8.4.3.3	X520 encoder system interface	193
8.4.3.4	X521 / X531 alternative encoder system interface	195
8.4.3.5	X524 Electronics power supply	197
8.4.4	Connection examples	197
8.4.5	Meaning of LEDs	199
8.4.6	Dimension drawing	200
8.4.7	Mounting	201
8.4.8	Protective conductor connection and shield support	202
8.4.9	Technical data	203
8.5	Option module Safe Brake Relay	208
8.5.1	Description	208
8.5.2	Safety instructions for Safe Brake Relays	208
8.5.3	Interface description	209
8.5.3.1	Overview	209
8.5.3.2	X524 electronics power supply	209
8.5.3.3	Brake connection	210
8.5.4	Connection example	210
8.5.5	Dimension drawing	211
8.5.6	Mounting	211
8.5.7	Technical data	211
9	Accessories	213
9.1	DRIVE-CLiQ cabinet bushing	213
9.1.1	Description	213
9.1.2	Safety Information	213
9.1.3	Interface description	214

9.1.3.1	Overview	214
9.1.4	Dimension drawings.....	215
9.1.5	Mounting	216
9.1.5.1	DRIVE-CLiQ cabinet bushing for cables with RJ45 connectors	216
9.1.5.2	DRIVE-CLiQ cabinet bushing for cables with M12 plug/socket.....	218
9.1.6	Technical data.....	219
9.2	DRIVE-CLiQ coupling	220
9.2.1	Description	220
9.2.2	Safety Information.....	220
9.2.3	Interface description.....	220
9.2.3.1	Overview	220
9.2.4	Dimension drawing	221
9.2.5	Mounting	221
9.2.6	Technical data.....	222
9.3	Mounting frame	222
9.3.1	Description	222
9.3.2	Dimension drawings.....	223
9.3.3	Mounting	225
10	Cabinet design and EMC for components, Blocksize format	227
10.1	General information	227
10.2	Safety instructions for control panel manufacturing.....	228
10.3	Information on electromagnetic compatibility (EMC)	229
10.4	Cable shielding and routing	230
10.5	24 V DC Supply Voltage	232
10.5.1	General information	232
10.5.2	Overcurrent protection	234
10.5.3	Overvoltage protection.....	235
10.5.4	Typical 24 V current consumption of the components.....	235
10.5.5	Selecting power supply units	236
10.6	Protective connection and equipotential bonding	237
10.7	Notes on electrical cabinet cooling	239
10.7.1	General information	239
10.7.2	Ventilation	240
10.7.3	Power loss of components during rated operation	242
10.7.3.1	General information	242
10.7.3.2	Power loss for Control Units and Sensor Modules	243
10.7.3.3	Power loss for line reactors and line filters	243
10.7.3.4	Power loss for Power Modules	243
10.7.3.5	Power losses for motor reactors	244
11	Service and maintenance.....	245
11.1	Safety instructions for service and maintenance	245
11.2	Service and maintenance for components, Blocksize format.....	246
11.2.1	Replacing hardware components	246
11.2.2	Replacing the fan on the PM240-2	246
11.3	Forming the DC link capacitors.....	248

11.4	Spare parts.....	251
11.5	Recycling and disposal	251
A	Annex.....	253
A.1	List of abbreviations	253
A.2	Documentation overview.....	262
A.3	Spring-type terminals/screw-type terminals	263
	Index	265

Fundamental safety instructions

1.1 General safety instructions



DANGER

Danger to life due to live parts and other energy sources

Death or serious injury can result when live parts are touched.

- Only work on electrical devices when you are qualified for this job.
- Always observe the country-specific safety rules.

Generally, six steps apply when establishing safety:

1. Prepare for shutdown and notify all those who will be affected by the procedure.
2. Disconnect the machine from the supply.
 - Switch off the machine.
 - Wait until the discharge time specified on the warning labels has elapsed.
 - Check that it really is in a no-voltage condition, from phase conductor to phase conductor and phase conductor to protective conductor.
 - Check whether the existing auxiliary supply circuits are de-energized.
 - Ensure that the motors cannot move.
3. Identify all other dangerous energy sources, e.g. compressed air, hydraulic systems, or water.
4. Isolate or neutralize all hazardous energy sources by closing switches, grounding or short-circuiting or closing valves, for example.
5. Secure the energy sources against switching on again.
6. Ensure that the correct machine is completely interlocked.

After you have completed the work, restore the operational readiness in the inverse sequence.



WARNING

Danger to life through a hazardous voltage when connecting an unsuitable power supply

Touching live components can result in death or severe injury.

- Only use power supplies that provide SELV (Safety Extra Low Voltage) or PELV- (Protective Extra Low Voltage) output voltages for all connections and terminals of the electronics modules.



! WARNING

Danger to life when live parts are touched on damaged devices

Improper handling of devices can cause damage.

For damaged devices, hazardous voltages can be present at the enclosure or at exposed components; if touched, this can result in death or severe injury.

- Ensure compliance with the limit values specified in the technical data during transport, storage and operation.
- Do not use any damaged devices.



! WARNING

Danger to life through electric shock due to unconnected cable shields

Hazardous touch voltages can occur through capacitive cross-coupling due to unconnected cable shields.

- As a minimum, connect cable shields and the conductors of power cables that are not used (e.g. brake cores) at one end at the grounded housing potential.



! WARNING

Danger to life due to electric shock when not grounded

For missing or incorrectly implemented protective conductor connection for devices with protection class I, high voltages can be present at open, exposed parts, which when touched, can result in death or severe injury.

- Ground the device in compliance with the applicable regulations.



! WARNING

Danger to life due to electric shock when opening plug connections in operation

When opening plug connections in operation, arcs can result in severe injury or death.

- Only open plug connections when the equipment is in a no-voltage state, unless it has been explicitly stated that they can be opened in operation.

 **WARNING****Danger to life due to fire spreading if housing is inadequate**

Fire and smoke development can cause severe personal injury or material damage.

- Install devices without a protective housing in a metal control cabinet (or protect the device by another equivalent measure) in such a way that contact with fire is prevented.
- Ensure that smoke can only escape via controlled and monitored paths.

 **WARNING****Danger to life through unexpected movement of machines when using mobile wireless devices or mobile phones**

Using mobile wireless devices or mobile phones with a transmit power > 1 W closer than approx. 2 m to the components may cause the devices to malfunction, influence the functional safety of machines therefore putting people at risk or causing material damage.

- Switch the wireless devices or mobile phones off in the immediate vicinity of the components.

 **WARNING****Danger to life due to the motor catching fire in the event of insulation overload**

There is higher stress on the motor insulation through a ground fault in an IT system. If the insulation fails, it is possible that death or severe injury can occur as a result of smoke and fire.

- Use a monitoring device that signals an insulation fault.
- Correct the fault as quickly as possible so the motor insulation is not overloaded.

 **WARNING****Danger to life due to fire if overheating occurs because of insufficient ventilation clearances**

Inadequate ventilation clearances can cause overheating of components with subsequent fire and smoke. This can cause severe injury or even death. This can also result in increased downtime and reduced service lives for devices/systems.

- Ensure compliance with the specified minimum clearance as ventilation clearance for the respective component.

 **WARNING**

Danger of an accident occurring due to missing or illegible warning labels

Missing or illegible warning labels can result in accidents involving death or serious injury.

- Check that the warning labels are complete based on the documentation.
- Attach any missing warning labels to the components, in the national language if necessary.
- Replace illegible warning labels.

NOTICE

Device damage caused by incorrect voltage/insulation tests

Incorrect voltage/insulation tests can damage the device.

- Before carrying out a voltage/insulation check of the system/machine, disconnect the devices as all converters and motors have been subject to a high voltage test by the manufacturer, and therefore it is not necessary to perform an additional test within the system/machine.

 **WARNING**

Danger to life when safety functions are inactive

Safety functions that are inactive or that have not been adjusted accordingly can cause operational faults on machines that could lead to serious injury or death.

- Observe the information in the appropriate product documentation before commissioning.
- Carry out a safety inspection for functions relevant to safety on the entire system, including all safety-related components.
- Ensure that the safety functions used in your drives and automation tasks are adjusted and activated through appropriate parameterizing.
- Perform a function test.
- Only put your plant into live operation once you have guaranteed that the functions relevant to safety are running correctly.

Note

Important safety notices for Safety Integrated functions

If you want to use Safety Integrated functions, you must observe the safety notices in the Safety Integrated manuals.

1.2 Safety instructions for electromagnetic fields (EMF)



WARNING

Danger to life from electromagnetic fields

Electromagnetic fields (EMF) are generated by the operation of electrical power equipment such as transformers, converters or motors.

People with pacemakers or implants are at a special risk in the immediate vicinity of these devices/systems.

- Ensure that the persons involved are the necessary distance away (minimum 2 m).

1.3 Handling electrostatic sensitive devices (ESD)

Electrostatic sensitive devices (ESD) are individual components, integrated circuits, modules or devices that may be damaged by either electric fields or electrostatic discharge.



NOTICE

Damage through electric fields or electrostatic discharge

Electric fields or electrostatic discharge can cause malfunctions through damaged individual components, integrated circuits, modules or devices.

- Only pack, store, transport and send electronic components, modules or devices in their original packaging or in other suitable materials, e.g. conductive foam rubber or aluminum foil.
- Only touch components, modules and devices when you are grounded by one of the following methods:
 - Wearing an ESD wrist strap
 - Wearing ESD shoes or ESD grounding straps in ESD areas with conductive flooring
- Only place electronic components, modules or devices on conductive surfaces (table with ESD surface, conductive ESD foam, ESD packaging, ESD transport container).

1.4 Industrial security

Note

Industrial security

Siemens provides products and solutions with industrial security functions that support the secure operation of plants, solutions, machines, equipment and/or networks. They are important components in a holistic industrial security concept. With this in mind, Siemens' products and solutions undergo continuous development. Siemens recommends strongly that you regularly check for product updates.

For the secure operation of Siemens products and solutions, it is necessary to take suitable preventive action (e.g. cell protection concept) and integrate each component into a holistic, state-of-the-art industrial security concept. Third-party products that may be in use should also be considered. For more information about industrial security, visit this address (<http://www.siemens.com/industrialsecurity>).

To stay informed about product updates as they occur, sign up for a product-specific newsletter. For more information, visit this address (<http://support.automation.siemens.com>).

WARNING

Danger as a result of unsafe operating states resulting from software manipulation

Software manipulation (e.g. by viruses, Trojan horses, malware, worms) can cause unsafe operating states to develop in your installation which can result in death, severe injuries and/or material damage.

- Keep the software up to date.
You will find relevant information and newsletters at this address (<http://support.automation.siemens.com>).
- Incorporate the automation and drive components into a holistic, state-of-the-art industrial security concept for the installation or machine.
You will find further information at this address (<http://www.siemens.com/industrialsecurity>).
- Make sure that you include all installed products into the holistic industrial security concept.

1.5 Residual risks of power drive systems

The control and drive components of a drive system are approved for industrial and commercial use in industrial line supplies. Their use in public line supplies requires a different configuration and/or additional measures.

These components may only be operated in closed housings or in higher-level control cabinets with protective covers that are closed, and when all of the protective devices are used.

These components may only be handled by qualified and trained technical personnel who are knowledgeable and observe all of the safety instructions on the components and in the associated technical user documentation.

When assessing the machine's risk in accordance with the respective local regulations (e.g., EC Machinery Directive), the machine manufacturer must take into account the following residual risks emanating from the control and drive components of a drive system:

1. Unintentional movements of driven machine components during commissioning, operation, maintenance, and repairs caused by, for example,
 - Hardware and/or software errors in the sensors, control system, actuators, and cables and connections
 - Response times of the control system and of the drive
 - Operation and/or environmental conditions outside the specification
 - Condensation/conductive contamination
 - Parameterization, programming, cabling, and installation errors
 - Use of wireless devices/mobile phones in the immediate vicinity of the control system
 - External influences/damage
2. In the event of a fault, exceptionally high temperatures, including an open fire, as well as emissions of light, noise, particles, gases, etc. can occur inside and outside the inverter, e.g.:
 - Component failure
 - Software errors
 - Operation and/or environmental conditions outside the specification
 - External influences/damage

Inverters of the Open Type/IP20 degree of protection must be installed in a metal control cabinet (or protected by another equivalent measure) such that contact with fire inside and outside the inverter is not possible.

3. Hazardous shock voltages caused by, for example,
 - Component failure
 - Influence during electrostatic charging
 - Induction of voltages in moving motors
 - Operation and/or environmental conditions outside the specification
 - Condensation/conductive contamination
 - External influences/damage
4. Electrical, magnetic and electromagnetic fields generated in operation that can pose a risk to people with a pacemaker, implants or metal replacement joints, etc., if they are too close
5. Release of environmental pollutants or emissions as a result of improper operation of the system and/or failure to dispose of components safely and correctly

Note

The components must be protected against conductive contamination (e.g. by installing them in a control cabinet with degree of protection IP54 according to IEC 60529 or NEMA 12).

Assuming that conductive contamination at the installation site can definitely be excluded, a lower degree of cabinet protection may be permitted.

For more information about residual risks of the components in a drive system, see the relevant sections in the technical user documentation.

System overview

2.1 Field of application

SINAMICS is the family of drives from Siemens designed for machine and plant engineering applications. SINAMICS offers solutions for all drive tasks:

- Simple pump and fan applications in the process industry.
- Complex individual drives in centrifuges, presses, extruders, elevators, as well as conveyor and transport systems.
- Drive line-ups in textile, plastic film, and paper machines, as well as in rolling mill plants.
- High-precision servo drives in the manufacture of wind turbines
- Highly dynamic servo drives for machine tools, as well as packaging and printing machines.

Depending on the application, the SINAMICS range offers the ideal version for any drive task.

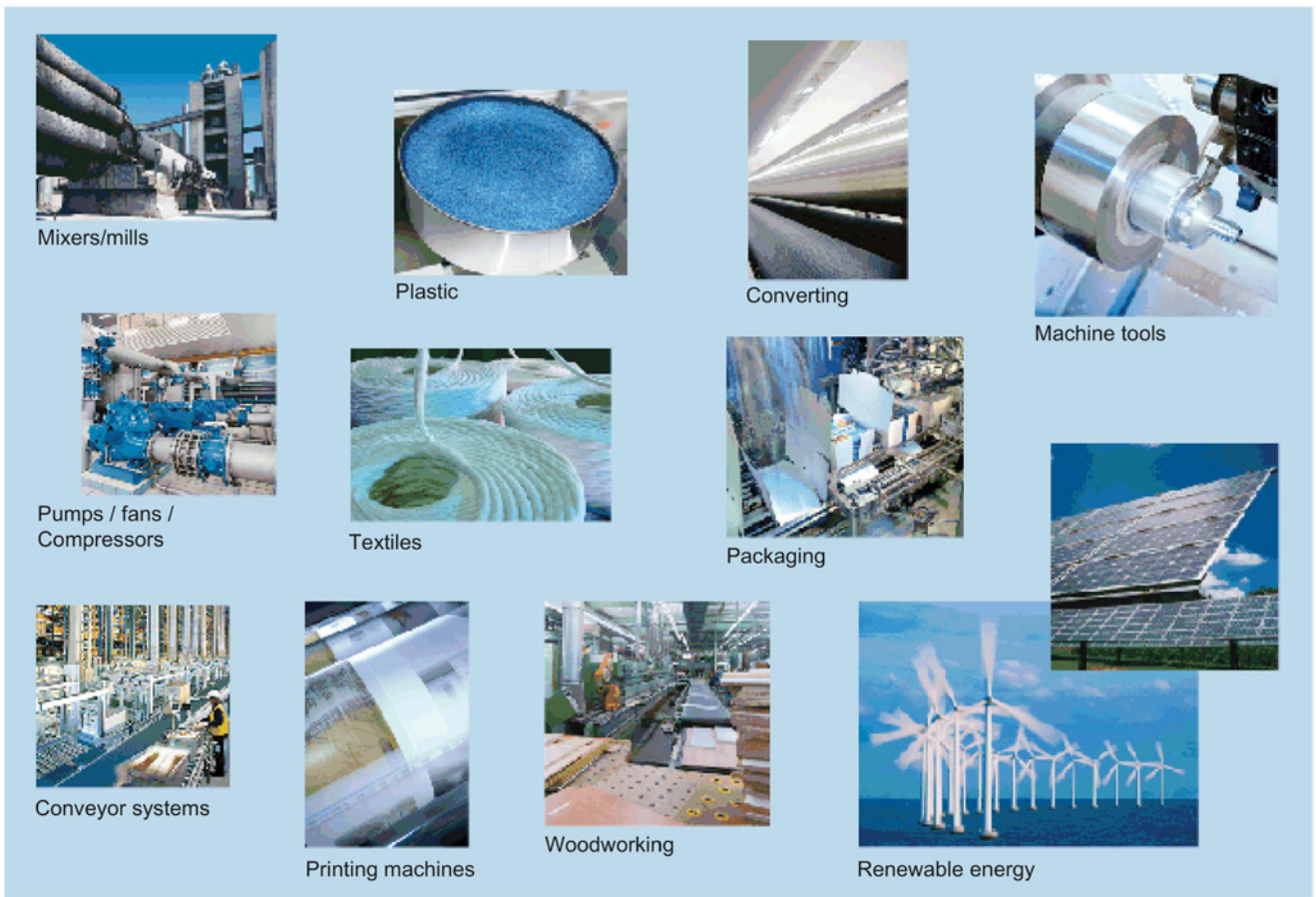

Figure 2-1 SINAMICS applications

Depending on the application, the SINAMICS range offers the ideal variant for any drive task.

- SINAMICS G is designed for standard applications with induction motors. These applications have less stringent requirements regarding the dynamic performance of the motor speed.
- SINAMICS S handles complex drive tasks with synchronous and induction motors and meets stringent requirements for:
 - Dynamics and accuracy
 - Integration of extensive technical functions in the drive control system
- SINAMICS DC MASTER is the DC drive of the SINAMICS family. As a result of its standard expandability, it addresses both basic as well as demanding drive applications and in complementary markets.

2.2 Platform Concept and Totally Integrated Automation

All SINAMICS versions are based on a platform concept. Joint hardware and software components, as well as standardized tools for design, configuration, and commissioning tasks ensure high-level integration across all components. SINAMICS handles a wide variety of drive tasks with no system gaps. The different SINAMICS versions can be easily combined with each other.

Totally Integrated Automation (TIA) with SINAMICS S110

Apart from SIMATIC, SIMOTION and SINUMERIK, SINAMICS is one of the core components of TIA. The STARTER commissioning tool is an integral element of the TIA platform. It is thus possible to parameterize, program and commission all components in the automation system using a standardized engineering platform and without any gaps. The system-wide data management functions ensure consistent data and simplify archiving of the entire plant project.

SINAMICS S110 supports PROFIBUS DP, the standard field bus of the TIA system. It provides a high-performance, system-wide communication network which links all automation components: HMI, controls, drives and I/O devices.

SINAMICS S110 is also available with a PROFINET interface. This Ethernet-based bus allows the rapid exchange of control data via PROFINET IO.

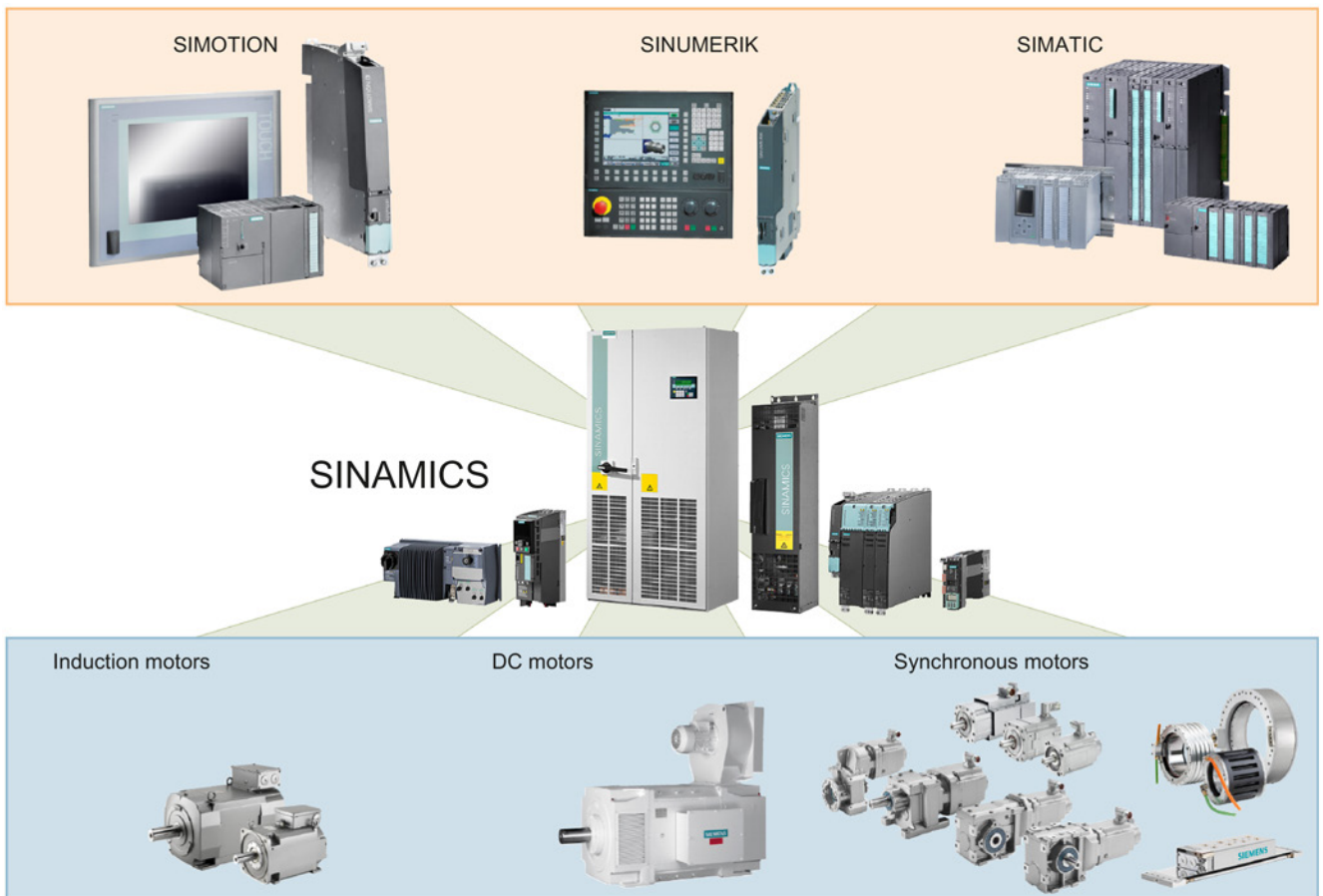

Figure 2-2 SINAMICS as part of the Siemens modular automation system

2.3 Overview of SINAMICS S110

SINAMICS S110 is the "simple servo" in the range of SINAMICS AC Drives. As a modular drive system for single axes in "servo" control mode, it is primarily used for simple positioning tasks in a wide range of industrial applications.

Typical areas of application for positioning, setting up and referencing include:

- Simple infeed tasks (e.g. rotary indexing tables)
- Handling technology, robotics
- Pick & place tasks
- Printing and paper machines
- Packaging machines

As a combination of a power unit (Power Module) and a Control Unit (CU), the SINAMICS S110 forms a single-motor drive in a compact format for machinery and plant construction.

SIZER, a high-performance engineering tool, makes it easier to choose and determine the optimum drive configuration. The drive can be simply commissioned a user-friendly fashion using the STARTER commissioning tool.

SINAMICS S110 can be used to operate synchronous and induction motors. Direct drives, such as linear and torque motors, can only be operated with SINAMICS S120.

2.4 System data

Table 2- 1 Electrical data

Line voltage	FSA ... FSC: 1/3 AC: 200 ... 240 V ± 10 % 3-phase AC: 380 ... 480 V ± 10 % FSD ... FSE 3 AC: 380 ... 480 V -20/+10 %
Line frequency	47 ... 63 Hz
Output voltage	1-phase AC: 0 V to 0.74 · line voltage 3-phase AC: 0 V to 0.95 · line voltage
Rated pulse frequency	<ul style="list-style-type: none"> For Power Modules with line voltages 1/3 AC 200 ... 240 V or 3 AC 380 ... 480 V and a type rating of $I_n < 110$ kW: 4 kHz <p>The pulse frequency can be increased in steps of 2 kHz; the maximum value is listed in the Technical Data of the relevant Power Module. On overload, a reduction to 2 kHz is permitted.</p> <p>If the rated pulse frequency is exceeded, you must consider the associated characteristics for the current derating. You will find more information in Chapter Derating (Page 31).</p>
Electronic power supply	24 V DC -15/+20% ¹⁾ , protective/safe extra low voltage (PELV/SELV)
Short-circuit current rating SCCR in accordance with UL508C (up to 600 V)	1.1 ... 447 kW: 65 kA UL approval applies only in conjunction with the fuses prescribed by Siemens and not with other types or circuit breakers alone.
EMC Directive acc. to EN 61800-3	Category C3 (option) Category C2 (option) Category C1 (option) for systems implemented in conformance with the documentation
Overvoltage category	III
Pollution degree	2

¹⁾ If a motor holding brake is used, restricted voltage tolerances (± 10 %) may have to be taken into account.

Table 2- 2 Environmental conditions

Degree of protection	IPXXB according to EN 60529, open type according to UL 508
Protection class	
Power circuits	I (with PE conductor connection)
Electronic circuits	III (protective/safe extra low voltage PELV/SELV)
Type of cooling	Internal air cooling, power units with forced air cooling using an integrated fan External air cooling
Permissible cooling medium temperature (air) and installation altitude during operation	<ul style="list-style-type: none"> 0°C ... +40°C and up to 1000 m installation altitude: Without derating > +40 ... +60°C: See characteristic for current derating Installation altitude > 1000 m ... 4000 m: See characteristic for current derating or reduction of the ambient temperature by 3.5 K per 500 m

Chemically active substances	
Long-term storage in the transport packaging	Class 1C2 according to EN 60721-3-1
Transport in the transport packaging	Class 2C2 according to EN 60721-3-2
Operation	Class 3C2 for the drive system, class 3C3 for the Power Modules acc. to EN 60721-3-3
Biological environmental conditions	
Storage in the transport packaging	Class 1B1 according to EN 60721-3-1
Transport in the transport packaging	Class 2B1 according to EN 60721-3-2
Operation	Class 3B1 according to EN 60721-3-3
Vibratory load	
Long-term storage in the transport packaging	Class 1M2 in accordance with EN 60721-3-1
Transport in the transport packaging	Class 2M3 in accordance with EN 60721-3-2
Operation	Class 3M2 according to EN 60721-3-3
Shock load	
Long-term storage in the transport packaging	Class 1M2 in accordance with EN 60721-3-1
Transport in the transport packaging	Class 2M3 in accordance with EN 60721-3-2
Operation	Class 3M2 according to EN 60721-3-3
Climatic environmental conditions	
Long-term storage in the transport packaging	Class 1K4 according to EN 60721-3-1 Temperature: -25°C ... +55°C
Transport in the transport packaging	Class 2K4 according to EN 60721-3-2 Temperature: -40°C ... +70°C
Operation	Temperature: 0 ... +40°C Relative humidity: 5 ... 95 % (better than 3K3) Oil mist, salt mist, ice formation, condensation, dripping water, spraying water, splashing water and water jets are not permitted

Table 2- 3 Certificates

Declarations of conformity	CE (Low Voltage, EMC, and Machinery Directives)
Approvals	cULus acc. to UL 61800-5-1 CSA only with external surge protection devices C-Tick SEMI F47 KCC only with internal or external line filters WEEE (Waste Electrical & Electronic Equipment) RoHS EAC

2.5 Derating

The Power Modules are designed for operation under the following conditions:

- Installation altitude up to 1000 m above sea level
- Ambient temperature 0 °C to 40 °C
- Rated pulse frequency according to the Technical Data of the Power Module
- Output frequency above 22 Hz (FSA - FSC) or 10 Hz (FSD - FSE)

Derating as a function of the installation altitude

The air pressure and therefore the air density are lower at higher altitudes above mean sea level (MSL). The same quantity of air does not have the same cooling effect and the clearance between 2 electrical conductors can only isolate a lower voltage. Typical values for air pressure are summarized in the table below:

Table 2- 4 Air pressure for various installation altitudes

Installation altitude above sea level in [m]	0	1000	2000	3000	4000
Installation altitude above sea level in [ft]	0	3280	6561	9842	13123
Air pressure in mbar [kPa]	100	90	80	70	62

If the Power Modules are operated at installation altitudes > 1000 m above sea level, you must reduce the maximum possible output current as follows:

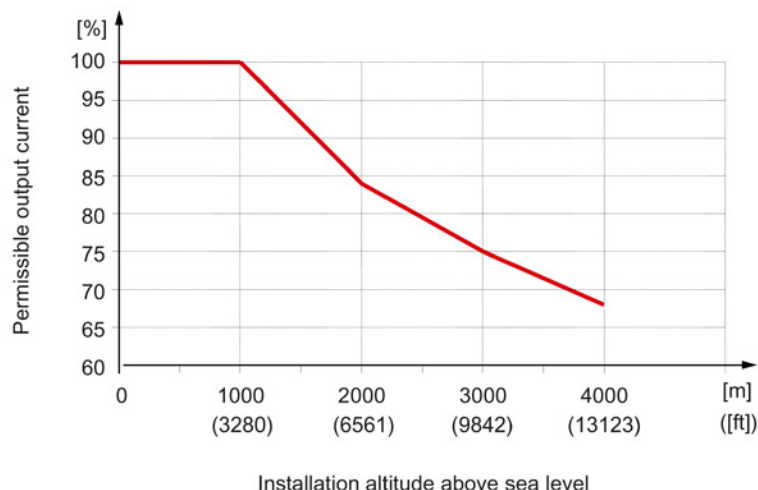

Figure 2-3 Reduction of the output current as a function of the installation altitude above sea level

A TN or TT system with grounded neutral point is required (no grounded line conductor) for installation altitudes above 2000 m. If the neutral point is not grounded, you must connect an isolating transformer upstream, the secondary side of which is then grounded at the neutral point.

A reduction of the line voltage phase-phase is not necessary.

Derating as a function of the ambient temperature

If the Power Modules are operated at ambient temperatures > 40 °C, you must reduce the maximum possible output current as follows:

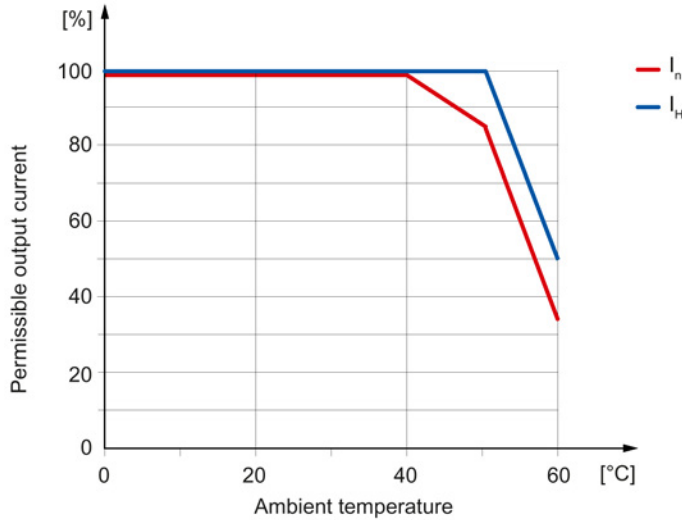

Figure 2-4 Reduction of the output current as a function of the temperature

The maximum permissible ambient temperature for all Power Modules is 60 °C.

Derating as a function of the pulse frequency

If the Power Modules are operated at a pulse frequency that is above the rated pulse frequency, you must reduce the maximum possible output current as follows: You will find the rated pulse frequency in the Technical Data of the relevant Power Module.

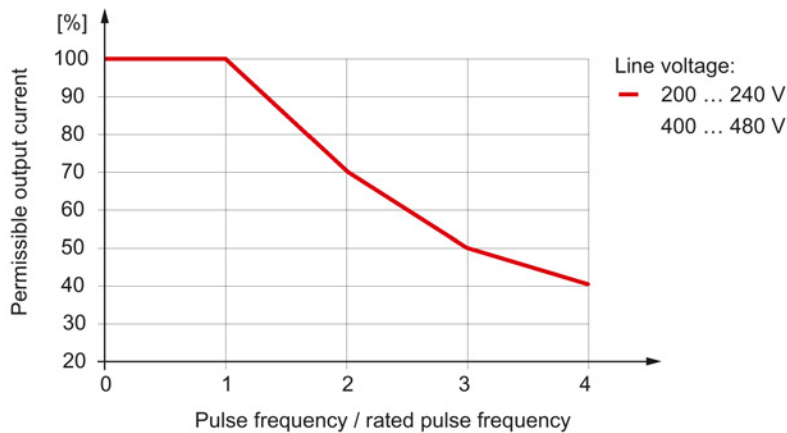

Figure 2-5 Reduction of the output current as a function of the quotient of the pulse frequency and rated pulse frequency

Derating as a function of the output frequency

FSA - FSC

If the Power Modules of frame sizes FSA - FSC are operated at an output frequency < 22 Hz, you must reduce the maximum possible output current as follows:

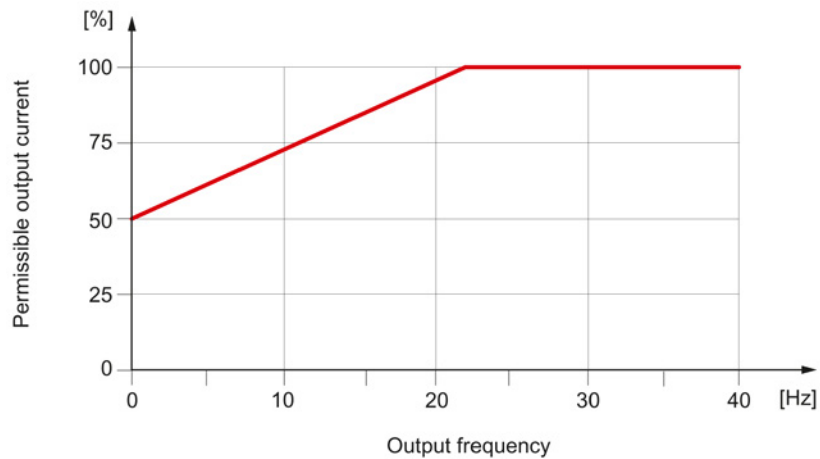

Figure 2-6 Reduction of the output current as a function of the output frequency (FSA - FSC)

FSD - FSE

For Power Modules of frame sizes FSD - FSE, the following derating must be considered for an output frequency of 10 Hz:

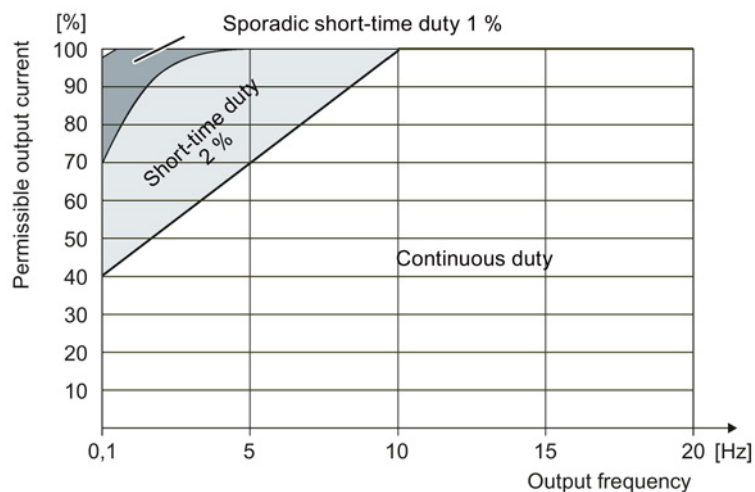

Figure 2-7 Reduction of the output current as a function of the output frequency (FSD - FSE)

Continuous duty	permissible operating state for the complete operating time
Short-time duty	operating state permissible for less than 2% of the operating time
Sporadic short-time duty	operating state only permissible for less than 1 % of the operating time

Mains connection and line-side power components

3.1 Introduction

You should use the following line-side components to connect a SINAMICS Blocksize drive line-up to the supply network:

- Line disconnector
- Overcurrent protection device (line fuse or circuit breaker)
- Line contactor (this is required for galvanic isolation)
- Line filter (only necessary to achieve EMC category C1 for Power Modules PM240-2 of frame sizes FSA, FSB, and FSC)
- Line reactor (only necessary for Power Modules PM240-2 FSA, FSB, and FSC)

Possible supply voltages for the drive line-up are:

- For Power Modules PM240-2 FSA, FSB, and FSC:
 - 1/3 AC 200 ... 240 V \pm 10 %
 - 3 AC 380 ... 480 V \pm 10 %
- For Power Modules PM240-2 FSD and FSE:
 - 3 AC 380 ... 480 V -20/+10 %

Available line reactor variants:

- External line reactors (Page 57) for PM240-2 Power Modules, frame sizes FSA to FSC
- In Power Modules PM240-2 frame sizes FSD and FSE, the line reactors are integrated.

Available line filter variants:

- Integrated (to achieve EMC category C2 or C3)
- External (to achieve EMC category C1)

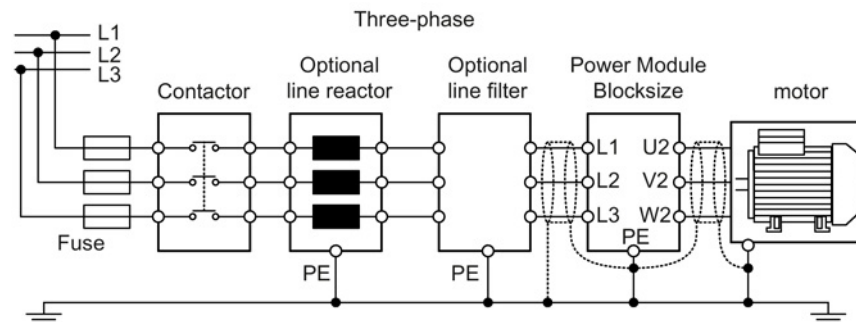

Figure 3-1 Example of a line connection for Power Modules Blocksize with no integrated line filter

3.2 Information on the disconnecter unit

A disconnecter unit is required for disconnecting the drive line-up from the supply system correctly. For this, you can use the disconnecter unit of the electrical equipment of the machine. The disconnecter unit must be selected in compliance with the requirements of the internationally binding standard relating to the electrical equipment of machines IEC 60204-1, Section 5.3. The relevant technical data and any other loads connected to the electrical equipment must be taken into account when making your selection.

The accessories required for the line disconnecter must be selected from the manufacturer catalogs. You will find detailed information in catalogs PM21 and NC61.

NOTICE
Damage to the drive electronics when switching the line disconnection equipment under load
When switching the line disconnection equipment (type according to the recommended selection) under load, then the contacts will be subject to premature wear. This can cause the line disconnection equipment to malfunction, with subsequent damage to the drive electronics.
<ul style="list-style-type: none">• Use a leading auxiliary break contactor and/or use a Voltage Sensing Module (VSM10).• If this is not possible, then avoid switching the line disconnection equipment under load.

3.3 Overcurrent protection by means of line fuses and circuit breakers

You must use line fuses or circuit-breakers for cable protection/overcurrent protection. NH, D, and DO type fuses with a gG or gS characteristic or suitable circuit-breakers according to IEC 60947 can be used for this purpose.



 WARNING
Danger to life due to electric shock and fire hazard caused by overcurrent protective equipment tripping too late
Overcurrent protective equipment that trips too late or not at all can cause electric shock or fire with heavy smoke. Persons in the danger zone can suffer serious injury or death.
<ul style="list-style-type: none">• Makes sure that the short-circuit power and loop impedance at the infeed point meet the requirements stated in the documentation so that the installed overcurrent protection equipment trips in time.• In TT systems, besides suitable overcurrent protection equipment, also use residual current devices (RCD) and, as of an infeed power of 55 kW or in extensive installations, also use residual current monitors (RCM).

Line voltage 1/3 AC 200 ... 240 V

Table 3- 1 Fuses for Power Modules PM240-2 FSA

Article No. without integrated line filter with integrated line filter		6SL3210– 1PB13-0UL0 1PB13-0AL0	6SL3210– 1PB13-8UL0 1PB13-8AL0	6SL3211– 1PB13-8UL0 1PB13-8AL0
Fuses UL Class J Rated current Short-circuit current rating SCCR	A kA	AJT15 15 40	AJT15 15 40	AJT15 15 40
Fuses NH IEC 60947 Rated current	A	3NA3803 10	3NA3805 16	3NA3805 16

Table 3- 2 Fuses for Power Modules PM240-2 FSB

Article No. without integrated line filter with integrated line filter		6SL3210– 1PB15-5UL0 1PB15-5AL0	6SL3210– 1PB17-4UL0 1PB17-4AL0	6SL3210– 1PB21-0UL0 1PB21-0AL0	6SL3211– 1PB21-0UL0 1PB21-0AL0
Fuses UL Class J Rated current Short-circuit current rating SCCR	A kA	AJT35 35 40	AJT35 35 40	AJT35 35 40	AJT35 35 40
Fuses NH IEC 60947 Rated current	A	3NE1814-0 20	3NE1815-0 25	3NE1803-0 35	3NE1803-0 35

Table 3- 3 Fuses for Power Modules PM240-2 FSC

Article No. without integrated line filter with integrated line filter		6SL3210– 1PB21-4UL0 1PB21-4AL0	6SL3210– 1PB21-8UL0 1PB21-8AL0	6SL3211– 1PB21-8UL0 1PB21-8AL0
Fuses UL Class J Rated current Short-circuit current rating SCCR	A kA	AJT50 50 40	AJT50 50 40	AJT50 50 40
Fuses NH IEC 60947 Rated current	A	3NE1817-0 50	3NE1818-0 63	3NE1818-0 63

Line voltage 3-phase 380 ... 480 V AC

Table 3- 4 Fuses for Power Modules PM240-2 FSA (1/2)

Article No. without integrated line filter with integrated line filter		6SL3210– 1PE11-8UL1 1PE11-8AL1	6SL3210– 1PE12-3UL1 1PE12-3AL1	6SL3210– 1PE13-2UL1 1PE13-2AL1	6SL3210– 1PE14-3UL1 1PE14-3AL1
Fuses UL Class J Rated current Short-circuit current rating SCCR	A kA	AJT10 10 65	AJT10 10 65	AJT15 15 65	AJT20 20 65
Fuses NH IEC 60947 Rated current	A	3NA3804 4	3NA3804 4	3NA3801 6	3NA3803 10

Table 3- 5 Fuses for Power Modules PM240-2 FSA (2/2)

Article No. without integrated line filter with integrated line filter		6SL3210– 1PE16-1UL1 1PE16-1AL1	6SL3210– 1PE18-0UL1 1PE18-0AL1	6SL3211– 1PE18-0UL1 1PE18-0UL1
Fuses UL Class J Rated current Short-circuit current rating SCCR	A kA	AJT30 30 65	AJT30 30 65	AJT30 30 65
Fuses NH IEC 60947 Rated current	A	3NA3803 10	3NA3805 16	3NA3805 16

Table 3- 6 Fuses for Power Modules PM240-2 FSB

Article No. without integrated line filter with integrated line filter		6SL3210– 1PE21-1UL0 1PE21-1AL0	6SL3210– 1PE21-4UL0 1PE21-4AL0	6SL3210– 1PE21-8UL0 1PE21-8AL0	6SL3211– 1PE21-8UL0 1PE21-8AL0
Fuses UL Class J Rated current Short-circuit current rating SCCR	A kA	AJT35 35 65	AJT35 35 65	AJT35 35 65	AJT35 35 65
Fuses NH IEC 60947 Rated current	A	3NE1814-0 20	3NE1815-0 25	3NE1803-0 35	3NE1803-0 35

3.3 Overcurrent protection by means of line fuses and circuit breakers

Table 3- 7 Fuses for Power Modules PM240-2 FSC

Article No. without integrated line filter with internal line filter		6SL3210– 1PE22-7UL0 1PE22-7AL0	6SL3210– 1PE23-3UL0 1PE23-3AL0	6SL3211– 1PE23-3UL0 1PE23-3AL0
Fuses UL Class J Rated current Short-circuit current rating SCCR	A kA	AJT50 50 65	AJT50 50 65	AJT50 50 65
Fuses NH IEC 60947 Rated current	A	3NE1817-0 50	3NE1817-0 50	3NE1817-0 50

Table 3- 8 Fuses for Power Modules PM240-2 FSD

Article No. without integrated line filter with internal line filter		6SL3210– 1PE23-8UL0 1PE23-8AL0	6SL3210– 1PE24-5UL0 1PE24-5AL0	6SL3210– 1PE26-0UL0 1PE26-0AL0	6SL3210– 1PE27-5UL0 1PE27-5AL0
Fuses UL Class J Rated current Short-circuit current rating SCCR	A kA	AJT60 60 65	AJT70 70 65	AJT90 90 65	AJT100 100 65
Fuses¹⁾ NH IEC 60947 Rated current	A	3NA3822 63	3NA3824 80	3NA3830 100	3NA3830 100
Fuses²⁾ UL Class J/NH IEC 60947 Rated current	A	3NE1818-0 63	3NE1820-0 80	3NE1021-0 100	3NE1021-0 100

1) Line protection

2) Line protection and protection of the Power Module

Table 3- 9 Fuses for Power Modules PM240-2 FSE

Article No. without integrated line filter with internal line filter		6SL3210– 1PE28-8UL0 1PE28-8AL0	6SL3210– 1PE31-1UL0 1PE31-1AL0
Fuses UL Class J Rated current Short-circuit current rating SCCR	A kA	AJT125 125 65	AJT150 150 65
Fuses¹⁾ NH IEC 60947 Rated current	A	3NA3832 125	3NA3836 160
Fuses²⁾ UL Class J/NH IEC 60947 Rated current	A	3NE1022-0 125	3NE1224-0 160

1) Line protection

2) Line protection and protection of the Power Module

3.4 Using residual-current devices

Selectively tripping, AC/DC-sensitive residual current devices (type B) can be used in addition to the overcurrent protection devices.

Residual current devices have to be installed if the power supply conditions in terms of short-circuit power and loop impedance at the infeed point are not such that the installed overcurrent protection devices will trip within the prescribed period if a fault occurs.

Residual current device (RCD)

Residual current operated circuit-breakers (RCD) can be used in addition to the overcurrent protection devices provided. They prevent excessively high touch currents being maintained. They are the preferred solution for TT systems.

Note the following conditions when using residual current operated circuit-breakers:

- Only use type B delayed tripping, selective AC/DC residual current operated circuit-breakers.
- Ensure that the loop impedance is maintained corresponding to local installation regulations.
- It is absolutely imperative that you connect parts of the drive system and the machine that can be touched with the PE conductor of the plant or system.
- The shielded motor cable must not be longer than 50 m.
- Use a separate residual current operated circuit-breaker for each Power Module.
- Ensure that the switching elements (disconnecter unit, contactors) for connecting and disconnecting the drive line-up have max. 35 ms delay time between the closing/opening of the individual main contacts.

If no residual current device is used, touch protection can be ensured by means of double insulation or by isolating the Power Module from the supply system through a transformer.

Residual current monitors (RCM)

Used in conjunction with appropriate circuit-breakers, residual current monitors (RCMs) provide fire and system protection even at high levels of grounding resistance (in TT systems, for example). When operating on TT systems for infeed powers exceeding 55 kW, and with systems that extend across a large area, residual current monitors must be installed in addition to the appropriate circuit breakers.

 WARNING
--

Fire hazard and danger of a plant standstill when residual currents occur
--

Undetected fault currents in the power supply can result in fires with smoke and therefore pose a hazard for persons or at least result in failures of the the entire plant.
--

- | |
|---|
| <ul style="list-style-type: none">• Always install residual current monitors in conjunction with suitable circuit-breakers. |
|---|

Note the points below when using residual current monitors:

- Use only AC/DC-sensitive RCM type B devices with delayed tripping that guarantee reliable tripping even for smoothed DC residual currents.
- Connect parts of the power drive system and the machine that can be touched to the PE conductor of the plant.
- Do not route the PE conductor through the measuring current transformer because this would remove its protection function.

3.5 Overvoltage protection

To protect the units against line-side surge voltages, you should install an overvoltage protection device directly at the infeed point (on the line side of the main disconnect switch). To comply with the requirements of CSA C22.2 No. 14-05, a type VZCA7 or VZCA8 surge arrester is absolutely mandatory. The Raycap company has suitable surge arresters.

3.6 Line contactors

A line contactor is required if the drive line-up needs to be electrically isolated from the power supply.

The characteristic values in the technical data apply when the line contactor is selected. You must consider the type of routing, the bundling factor, and the factor for the ambient temperature according to EN 60204-1 when dimensioning the conductors to be connected.

NOTICE
Damage to the drive electronics when switching the line contactor under load
If you switch the line contactor (recommended type) under load, the contacts will wear out prematurely. This may lead to faulty functioning of the contactor with subsequent damage to the drive electronics.
<ul style="list-style-type: none">• Use a leading auxiliary break contactor and/or use a Voltage Sensing Module (VSM10).• If this is not possible, avoid switching the line contactor under load.

Note

To limit the switching overvoltage, the contactor coil must be connected to an overvoltage limiter (e.g. freewheeling diode or varistor).

When the digital output is used to control the line contactor, you must consider the make/break capacity.

3.7 Line filter

3.7.1 Description

In conjunction with a system configuration that is consistently designed to ensure EMC, line filters limit the conducted interference emitted by the Power Modules to limit values according to EN 61800-3.

The Power Modules are available in variants with internal line filters. With these, the limit values of EMC categories C2 and C3 can be complied with. External filters are also available that comply with EMC category C1.

3.7.2 Safety instructions for line filters

 **WARNING**
Danger to life if the fundamental safety instructions and residual risks are not heeded

Failure to heed the fundamental safety instructions and residual risks in Chapter 1 can result in accidents causing severe injuries or death.

- Follow the fundamental safety instructions.
- Consider the residual risks on the risk assessment.

 **DANGER**
Danger to life due to electric shock in the event of missing touch protection

Death or serious injury can result when live parts are touched.

- For the line filter, use touch protection according to IPXXA or corresponding to the local installation regulations.

 **WARNING**
Danger of fire through overheating for insufficient ventilation clearances

Insufficient ventilation clearances result in overheating with danger to persons as a result of smoke and fire. Further, the line filter can be thermally damaged.

- Ensure 100-mm ventilation clearances above and below the line filter.

3.7 Line filter

NOTICE
Damage due to multiple loads being connected to the same line infeed point Damage may occur if multiple loads are connected to the same line infeed point. <ul style="list-style-type: none">• Suppress interference on the additional loads using appropriate line filters.
NOTICE
Line filter damage due to interchanged connections Interchanging the input and output connections will damage the line filters. <ul style="list-style-type: none">• Connect the incoming line supply cable to LINE L1, L2, L3.• Connect the outgoing cable to the Power Module at LOAD/LAST L1', L2', L3' (U, V, W).
NOTICE
Damage of further loads due to incorrect line filters Unsuitable line filters can cause line harmonics, which damage or destroy loads connected to the same line supply. <ul style="list-style-type: none">• Only use line filters released by Siemens for SINAMICS.

3.7.3 Classification of EMC behavior

The EMC environments and the EMC categories are defined in the EMC product standard EN 61800-3 as follows:

Environments

First environment (public systems)

An environment that includes domestic premises and establishments that are connected directly to a public low-voltage line supply without the use of an intermediate transformer.

Examples: Houses, apartments, commercial premises, or offices in residential buildings.

Second environment (industrial systems)

An environment that includes all other establishments that are not connected directly to a public low-voltage line supply.

Examples: Industrial areas and technical areas of buildings that are supplied by an assigned transformer.

Categories

Category C1

Drive systems with a rated voltage < 1000 V, which are intended for use in the first environment.

Drive systems which correspond to category C1 can be installed in the first environment without restrictions.

Category C2

Drive systems with a rated voltage < 1000 V, which are neither plug-in devices nor moveable devices and which, when used in the first environment, are intended only to be installed and commissioned by an expert.

Drive systems which correspond to category C2 may only be used in the first environment if they are installed by an expert, with limit values for electromagnetic compatibility observed.

Category C3

Drive systems with a rated voltage < 1000 V, which are intended for use in the second environment and not for use in the first environment.

Drive systems which correspond to category C3 may only be installed in the second environment.

Category C4

Drive systems with a rated voltage ≥ 1000 V with an output current ≥ 400 A or for use in complex systems in the second environment

Drive systems which correspond to category C4 may only be installed in the second environment.

Note

Expert

An expert is a person or organization with the necessary experience for installing and/or commissioning drive systems (Power Drive Systems - PDS), including the associated EMC aspects.

3.7.4 Electromagnetic compatibility (EMC) of the system

Category C1

In the following conditions, the Power Modules comply with the limit values of category C1:

- An external line filter provided for the Power Modules PM240-2 FSA, FSB, FSC is used.
- A shielded motor cable with low capacitance is used.
- The motor cable is shorter than 50 m.
- The pulse frequency is less than or equal to the rated pulse frequency.
- The current is less than or equal to the rated input current stated in the Technical Data

Power Modules that comply with the limit values of Category C1 are intended for use in the first environment.

Category C2

In the following conditions, the Power Modules comply with the limit values of category C2:

- An internal line filter is used.
- A shielded motor cable with low capacitance is used.
- The motor cable is shorter than 50 m.
- The pulse frequency is less than or equal to the rated pulse frequency.
- The current is less than or equal to the rated input current stated in the Technical Data

Power Modules with an additional line reactor with a line impedance $U_k \geq 4\%$ or a low harmonic filter (LHF) meet the requirements for the first environment. Without these measures, Power Modules of Category C2 can only be operated in the second environment.

Category C3

Power Modules with an integrated line filter comply with the limit values for category C3. The Power Modules of the Blocksize series are all available in variants with an integrated line filter.

The Power Modules of Category C3 and can only be used in the second environment.

Category C4

Unfiltered Power Modules meet Category C4 and can only be used in the second environment.

3.7.5 Dimension drawings

Blocksize line filter

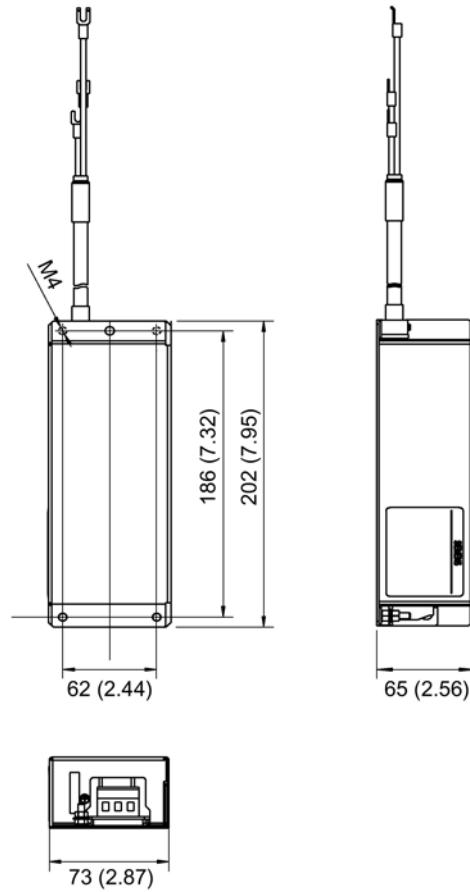

Figure 3-2 Dimension drawing of the line filter, Power Module PM240-2 frame size FSA, all data in mm (inches)

3.7 Line filter

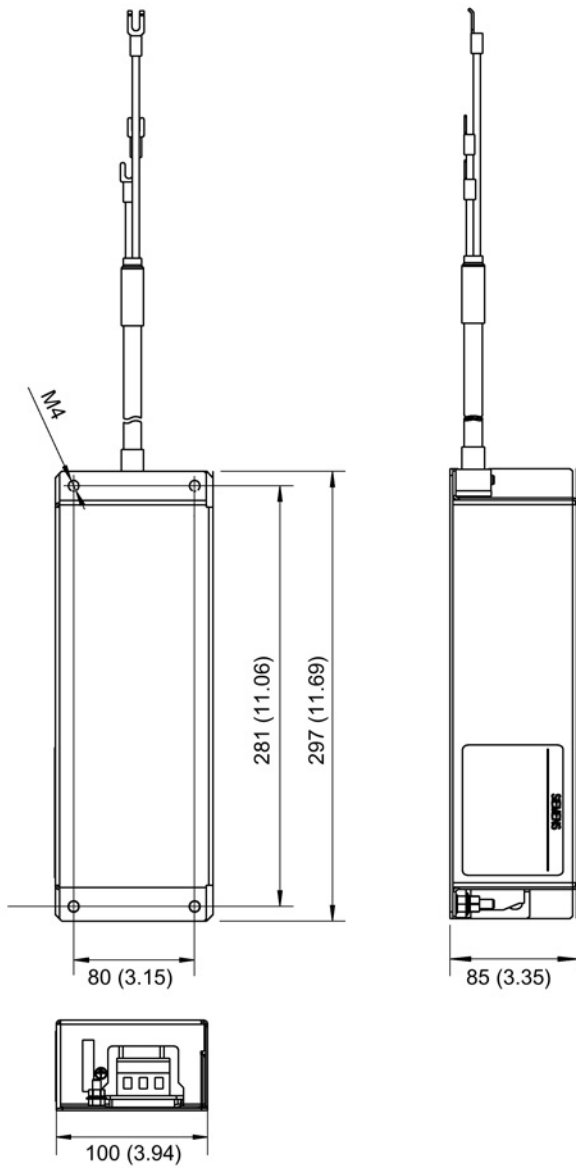

Figure 3-3 Dimension drawing of the line filter, Power Module PM240-2 frame size FSB, all data in mm (inches)

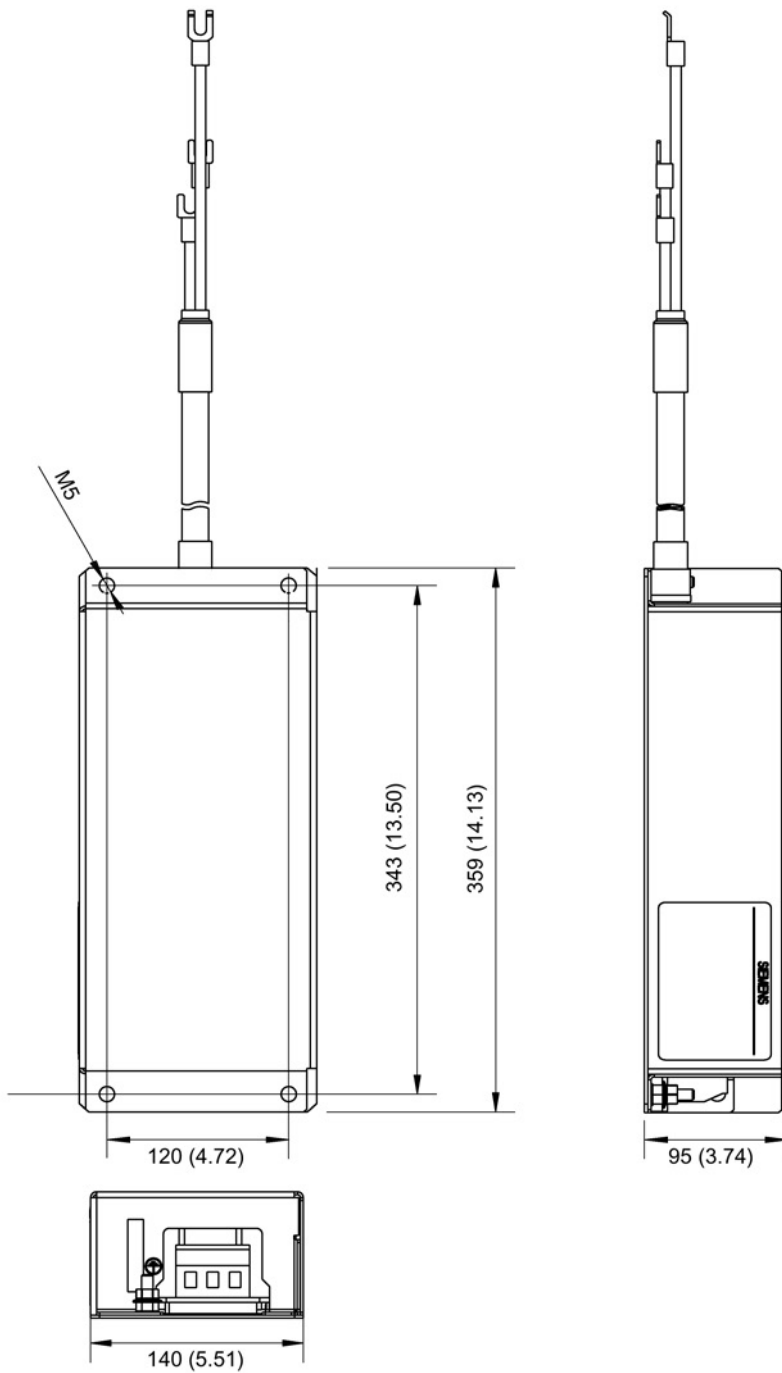
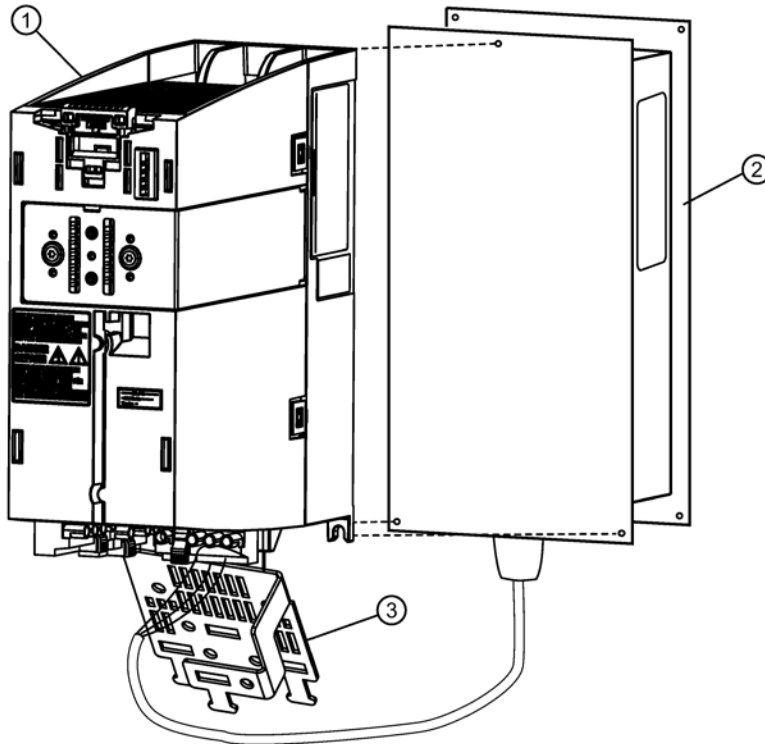

Figure 3-4 Dimension drawing of the line filter, Power Module PM240-2 frame size FSC, all data in mm (inches)

3.7 Line filter

3.7.6 Mounting

The external line filters are designed as base components. The line filter is retained on the mounting surface and the Power Module is mounted on the line filter in a space-saving fashion. The cables to the Power Modules are already connected at the line filter. The line filter is connected to the line supply through terminals.



- ① PM240-2 Power Module, frame size FSA
- ② Line filter
- ③ Shield connection

Figure 3-5 Installation example: Power Module PM240-2 (frame size FSA) with screening kit and line filter

Table 3- 10 Connecting the line filter for the PM240-2 on the mounting surface

Frame size	Fastening	Tightening torque
FSA	4 x M4 bolts	2.5 Nm
FSB		
FSC	4 x M5 bolts	3 Nm

Table 3- 11 Connecting Power Module PM240-2 to the line filter

Frame size	Fastening	Tightening torque
FSA	3 x M4 bolts	2.5 Nm
FSB	4 x M4 bolts	2.5 Nm
FSC	4 x M5 bolts	3 Nm

3.7.7 Technical data

Table 3- 12 Technical data of line filter Blocksize PM240-2

Line voltage 3-phase 380 to 480 V AC				
Line filter 6SL3203-		OBE17-7BA0	OBE21-8BA0	OBE23-8BA0
Rated current	A	11.4	23.5	49.4
Power loss	W	13	22	39
Line supply connection L1, L2, L3		Max. cross section that can be connected: 2.5 mm ² Tightening torque: 0.6 ... 0.8 Nm	Max. cross section that can be connected: 6 mm ² Tightening torque: 1.5 ... 1.8 Nm	Max. cross section that can be connected: 16 mm ² Tightening torque: 2.0 ... 2.3 Nm
Line supply connection L1', L2' L3', PE'		Cable (including PE') on the line filter		
PE connection 		Max. cross section that can be connected: 2.5 mm ² Tightening torque: 2.0 ±0.1 Nm	Max. cross section that can be connected: 6 mm ² Tightening torque: 2.0 ±0.1 Nm	Max. cross section that can be connected: 16 mm ² Tightening torque: 3.0 ±0.5 Nm
Degree of protection		IP20	IP20	IP20
Weight	kg	1.75	4.0	7.3
Suitable for Power Module		6SL3210- 1PE11-8UL1 1PE12-3UL1 1PE13-2UL1 1PE14-3UL1 1PE16-1UL1 1PE18-0UL1 6SL3211- 1PE18-0UL1	6SL3210- 1PE21-1UL0 1PE21-4UL0 1PE21-8UL0 6SL3211- 1PE21-8UL0	6SL3210- 1PE22-7UL0 1PE23-3UL0 6SL3211- 1PE23-3UL0
Frame size		FSA	FSB	FSC
Unit rating of the Power Module	kW	0.55 ... 3.0	4.0 ... 7.5	11 ... 15

3.8 Line reactors

3.8.1 Description

The line reactors limit low-frequency line harmonics and reduce the load on the rectifiers in the Power Modules. They are used to smooth voltage spikes (line supply faults) or to bridge voltage dips/interruptions when commutating.

Power Modules PM240-2 FSD and FSE have integrated DC link reactors and therefore do not need a line reactor.

3.8.2 Safety instructions for line reactors

 WARNING
Danger to life if the fundamental safety instructions and residual risks are not heeded Failure to heed the fundamental safety instructions and residual risks in Chapter 1 can result in accidents causing severe injuries or death. <ul style="list-style-type: none">• Follow the fundamental safety instructions.• Consider the residual risks on the risk assessment.



 DANGER
Danger to life due to electric shock in the event of missing touch protection Serious injury or death can result when live parts are touched. <ul style="list-style-type: none">• For the line reactors, use touch protection according to IPXXA or corresponding to the local installation regulations.

 WARNING
Danger of fire through overheating for insufficient ventilation clearances Insufficient ventilation clearances can result in overheating with danger to persons as a result of smoke and fire. Further, increased failures can occur and the service life of components shortened. <ul style="list-style-type: none">• Ensure 100-mm ventilation clearances above and below the component.

⚠ CAUTION**Risk of burns resulting from high surface temperatures of the line reactors**

The surface temperature of the line reactors may exceed 80° C. Contact with the surface can cause you to suffer severe burn injuries.

- Mount the line reactor so that it cannot be touched. If this is not possible, at the dangerous locations, attach an appropriate warning note that is clearly visible and easy to understand.

NOTICE**Damage to the system due to impermissible line reactors**

An impermissible line reactor may cause damage to the system and any further loads operated on the same power network.

- Only use line reactors that Siemens has authorized for SINAMICS.

NOTICE**Line reactor damage due to interchanged connections**

Interchanging the input and output connections will damage the line reactor.

- Connect the incoming power supply cable to 1L1, 1L2, 1L3.
- Connect the outgoing cable to the load at 2L1, 2L2, 2L3.

Note**Malfunctions through magnetic fields**

Reactors produce magnetic fields that can disturb or damage components and cables.

- Arrange the components and cables at a suitable distance (at least 200 mm) or shield the magnetic fields appropriately.

Note**Connection cables**

- Keep the connecting cables to the Power Module short (max. 5 m.)
- Use shielded connection cables.

3.8 Line reactors

3.8.3 Dimension drawings

Blocksize line reactors

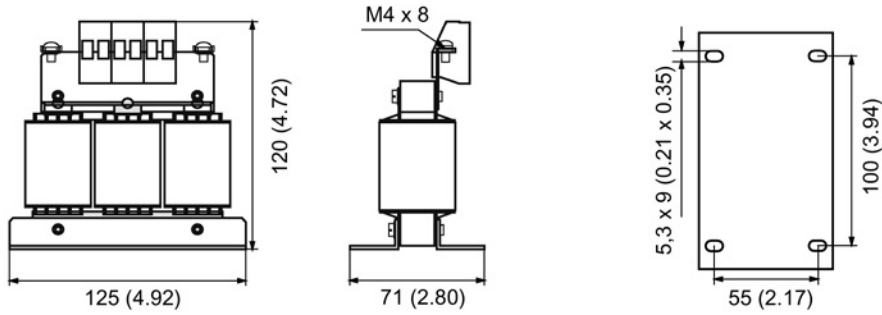

Figure 3-6 Dimension drawing of line reactors, PM240-2 frame size FSA, 0.55 ... 1.1 kW, all dimensions in mm and (inch)

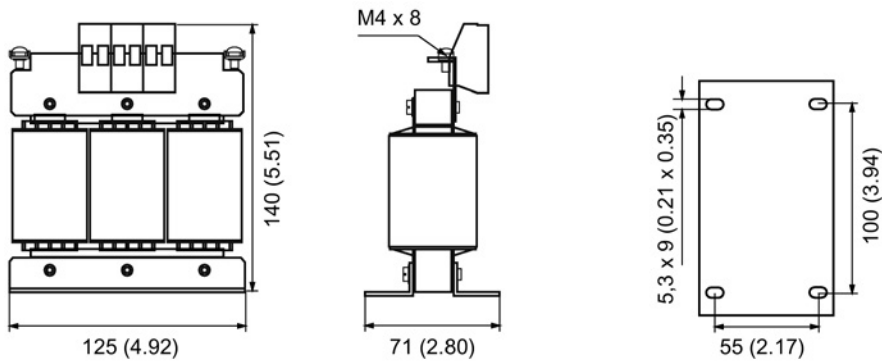

Figure 3-7 Dimension drawing of line reactors, PM240-2 frame size FSA, 1.5 ... 4.0 kW, all dimensions in mm and (inch)

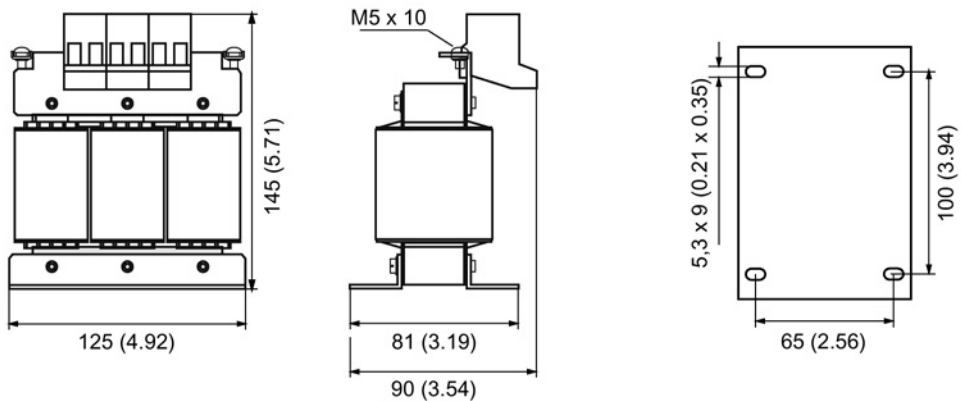

Figure 3-8 Dimension drawing of line reactors, PM240-2, frame size FSB, 4.0 ... 7.5 kW, all dimensions in mm and (inch)

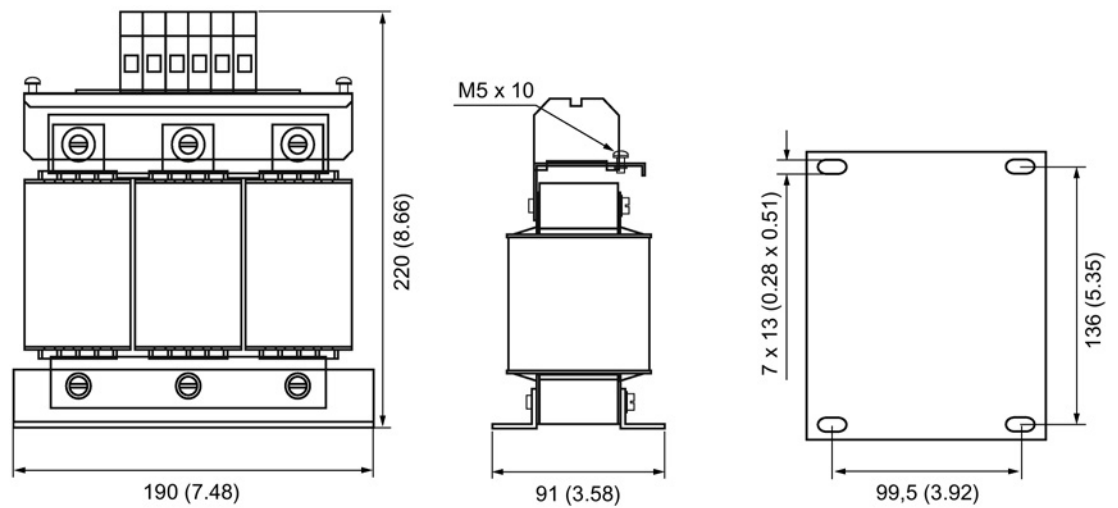

Figure 3-9 Dimension drawing of line reactors, PM240-2, frame size FSC, 11 ... 15 kW, all dimensions in mm and (inch)

3.8.4 Mounting

The line reactors for Power Modules PM240-2 of frame sizes FSA to FSC are designed for installation in a cabinet. The line reactor is installed on the mounting surface next to the Power Module. The line reactor is connected to the line supply through terminals.

Table 3- 13 Connecting the line reactor for the PM240-2 on the mounting surface

Frame size	Fastening	Tightening torque
FSA	4 x M5 screws	6 Nm
FSB	4 x M5 nuts 4 x M5 washers	
FSC	4 x M6 screws 4 x M6 nuts 4 x M6 washers	10 Nm

3.8.5 Electrical Connection

Line/load connection

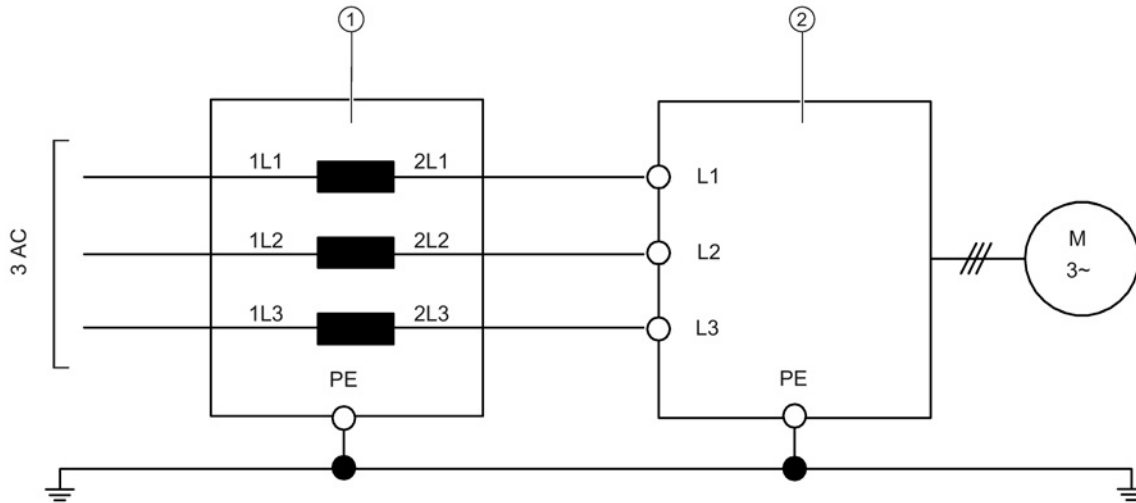

- ① Line reactor
- ② Power Module

Figure 3-10 Power Module with line filter

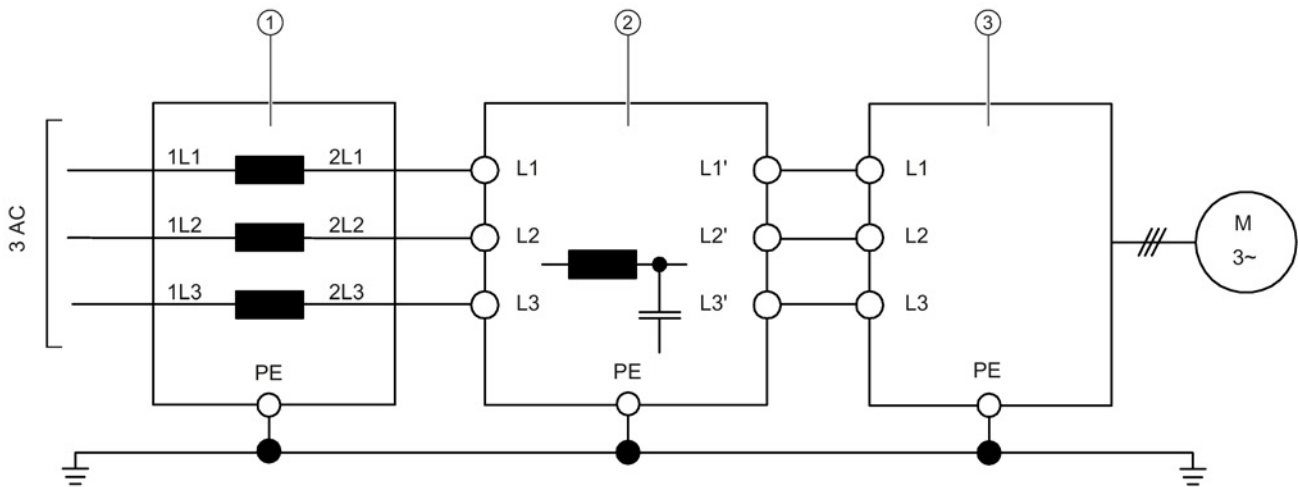

- ① Line reactor
- ② Line filter
- ③ Power Module

Figure 3-11 Power Module with line reactor and line filter

3.8.6 Technical data

Table 3- 14 Technical data line reactors PM240-2 FSA to FSC

Article No. 6SL3203-		OCE13-2AA0	OCE21-0AA0	OCE21-8AA0	OCE23-8AA0
Inductance	mH	2.5	1.0	0.5	0.3
Rated current	A	4.0	11.3	22.3	47.0
Power loss 50/60 Hz	W	23 / 25.3	36 / 39.6	53 / 58.3	88 / 96.8
Line/load connection 1L1, 1L2, 1L3 2L1, 2L2, 2L3		Max. cross section that can be connect- ed: 2.5 mm ² Tightening torque: 0.6 ... 0.8 Nm	Max. cross section that can be connect- ed: 2.5 mm ² Tightening torque: 0.6 ... 0.8 Nm	Max. cross section that can be connect- ed: 6 mm ² Tightening torque: 1.5 ... 1.8 Nm	Max. cross section that can be connect- ed: 16 mm ² Tightening torque: 2.0 ... 4.0 Nm
PE connection		Type: M4 bolts Tightening torque: 3 Nm	Type: M4 bolts Tightening torque: 3 Nm	Type: M5 bolts Tightening torque: 5 Nm	Type: M5 bolts Tightening torque: 5 Nm
Degree of protection		IP20	IP20	IP20	IP20
Weight	kg	1.10	2.10	2.95	7.80
Matching Power Mod- ules ¹⁾	Line voltage 1/3 AC 200 V -10 % to 240 V +10 %:				
		6SL3210- 1PB13-0xL0 1PB13-8xL0	6SL3210- 1PB15-5xL0 1PB17-4xL0 1PB21-0xL0	6SL3210- 1PB21-4xL0 1PB21-8xL0	
		6SL3211- 1PB13-8xL0	6SL3211- 1PB21-0xL0	6SL3211- 1PB21-8xL0	
	Line voltage 3-phase 380 V AC -10% to 480 V AC +10%:				
	6SL3210- 1PE11-8xL1 1PE12-3xL1 1PE13-2xL1	6SL3210- 1PE14-3xL1 1PE16-1xL1 1PE18-0xL1 6SL3211- 1PE18-0xL1	6SL3210- 1PE21-1xL0 1PE21-4xL0 1PE21-8xL0 6SL3211- 1PE21-8xL0	6SL3210- 1PE22-7xL0 1PE23-3xL0 6SL3211- 1PE23-3xL0	
Frame size		FSA	FSA	FSB	FSC
Unit rating of the Power Module	kW	0.55 ... 1.1	1.1 ... 3.0	3.0 ... 7.5	5.5 ... 15

1) x = A: Power Module with integrated line filter, x = U: Power Module without integrated line filter

3.9 Line connection variants

3.9.1 Operation on different line system configurations

The Power Modules are designed for the following power distribution systems according to IEC 60364-1.

Note

- At an installation altitude of more than 1000 m, heed the information in Chapter Derating (Page 31).
-

TN system

In a TN system, a point of the generator or the transformer is grounded, normally the neutral point. The housing of the consumer is also connected with the ground using this cable.

Neutral and PE conductors can be fed separately (N / PE) or together (PEN).

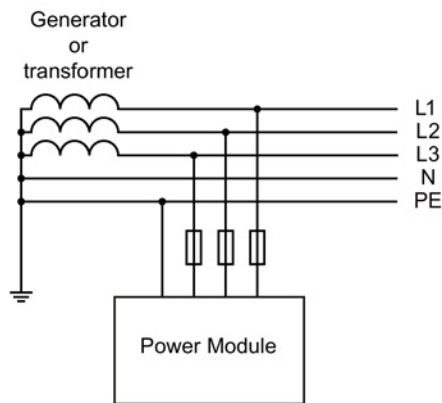

Figure 3-12 TN system

- Power Modules without line filter are permitted to be operated on all TN systems.
- Power Modules with integrated or external line filter are permitted to be operated only on TN systems with a grounded neutral point.

TT system

In a TT system, a point of the generator or the transformer is grounded, normally the neutral point. The housing of the consumer is connected with the ground using a separate cable.

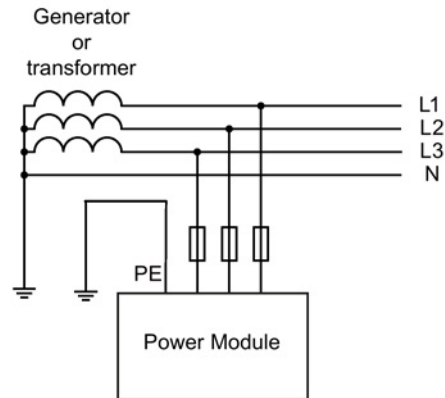

Figure 3-13 TT system

- Power Modules without a line filter can be operated on all TT systems.
- Power Modules with an integrated or external line filter can be operated only in TT systems with a grounded neutral point.

IT system

In an IT system, the voltage network is either not connected with ground or connected only using a high-resistance impedance. The housing of the consumer is connected with the ground using a separate cable.

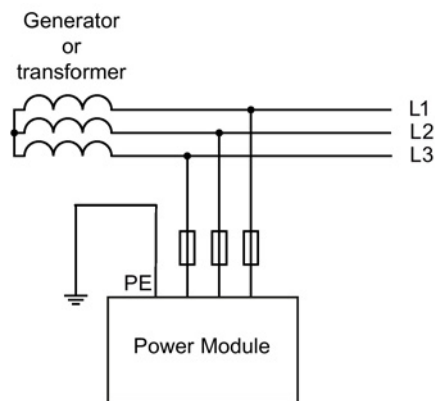

Figure 3-14 IT system

- Power Modules without a line filter can be operated in all IT systems.
- Power Modules with an integrated or external line filter can be operated only in IT systems.

NOTICE

Damage of the drive line-up when operating on an IT system without a motor reactor

If the drive unit is operated without a motor reactor in an IT system, a ground fault on the motor side of the Power Modules can cause damage to the drive line-up or trip the overcurrent protective equipment.

- Always operate the Power Modules in an IT system with motor reactors.

3.9.2 Methods of line connection

A distinction is made between the following line connection types:

- Direct operation of the power supply connection components on the supply system
- Operation of the line connection components via an autotransformer
- Operation of the line connection components via an isolating transformer

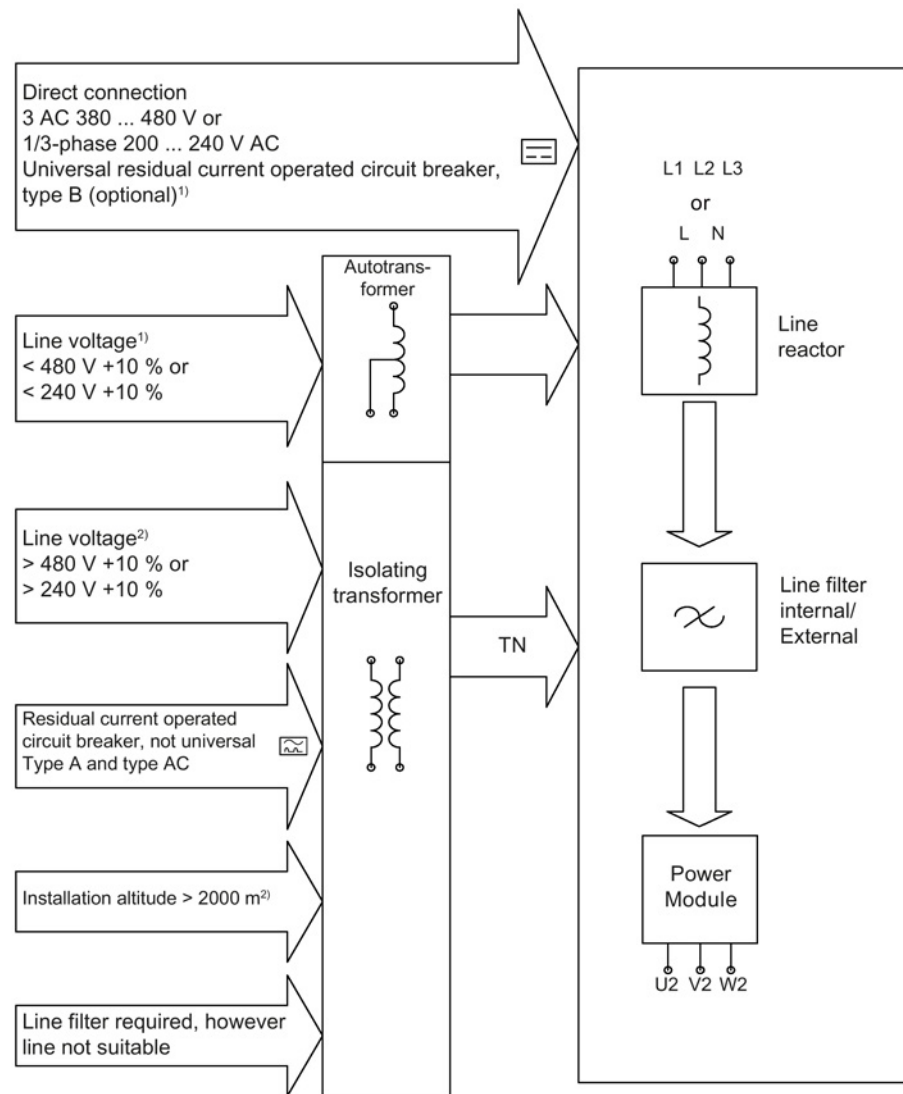

1) TN or TT systems with grounded neutral point, or IT systems with monitoring

2) Any line system

3) With grounded neutral point

Figure 3-15 Overview of line connection variants for SINAMICS S110



! WARNING

Danger to life due to electric shock if isolating transformer is omitted

To implement safe electrical separation, an isolating transformer must be used with high voltages. Otherwise, there is a danger to life.

- Install an isolating transformer for voltages of > 3-phase 480 V AC +10% or 240 V AC +10%.

Note

Line connection of motors

In combination with the drive system, the motors are generally approved for operation in TN and TT systems with grounded neutral point and in IT systems.

In use in IT systems, the occurrence of a first fault between a live part and ground must be signaled by a monitoring device. The first fault must be removed as quickly as possible to minimize temporary overload of the motor insulation.

In all other systems, except TN and TT systems with grounded neutral point and IT systems, such as systems with a grounded line conductor, an isolating transformer with grounded neutral point (secondary side) must be connected between the supply and the drive system to protect the motor insulation from continuous excessive stress.

3.9.3 Operation of the line connection components on the supply line

The SINAMICS S110 drive system is designed to be directly connected to TN and TT systems with a grounded neutral point as well as to IT systems without a line filter with rated voltages from 3-phase 380 V to 480 V AC and 1-phase 200 V to 240 V AC.

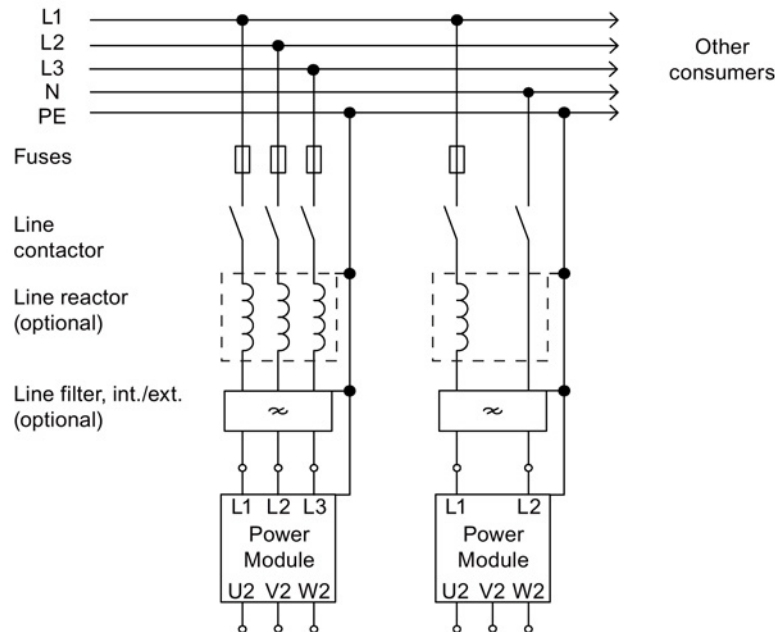

Figure 3-16 Direct operation on the line supply

Operation of single-phase units on the Single Phase Grounded Midpoint line system configuration

The line connection depicted below applies to the operation of single-phase units (1-phase 230 V AC) on the Single Phase Grounded Midpoint line system configuration commonly used in the USA:

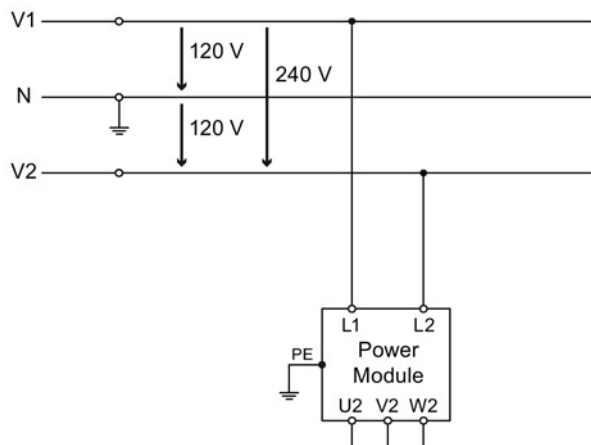

Figure 3-17 Direct operation on single phase grounded midpoint line system configurations

3.9.4 Operation of the line connection components via an autotransformer

An autotransformer can be used to adapt the voltage in the range up to 3-phase 480 VAC +10% or 240 VAC +10%.

Application example:

- The motor insulation must be protected from excessive voltages.

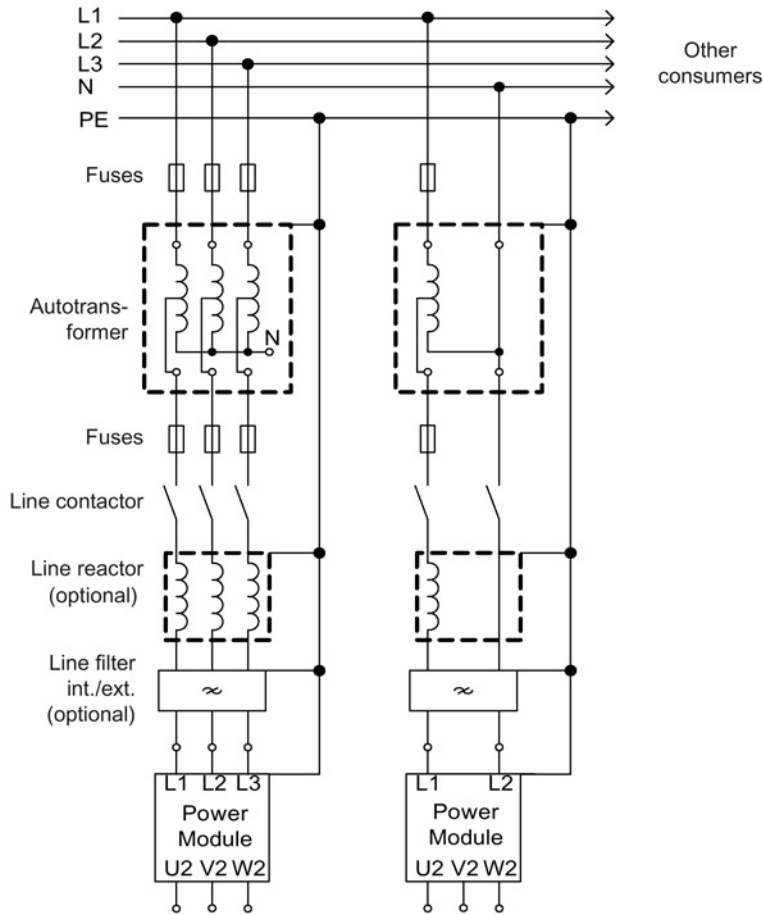

Figure 3-18 Auto-transformers

3.9.5 Operation of the line connection components via an isolating transformer

The isolating transformer converts the type of system grounding of the installation (e.g. IT system) to a TN system with grounded neutral point. Additional voltage adaptation to the permissible voltage tolerance range is possible.

An isolating transformer must be used in the following cases:

- The insulation of the Power Module and/or the motor is not adequate for the voltages that occur.
- There is no compatibility to an existing residual current device.
- The installation altitude is greater than 2000 m above sea level.
- A line filter should always be used for all systems that are not TN or TT systems with grounded neutral point.

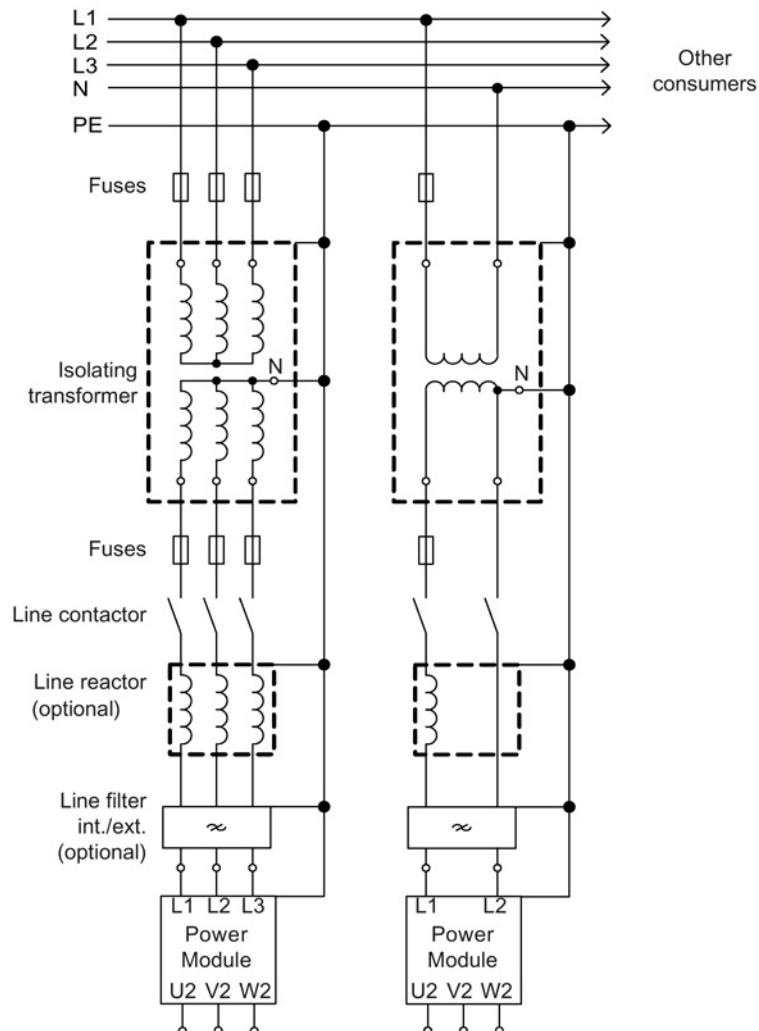

Figure 3-19 Isolating transformer

Blocksize Power Modules (PM240-2)

4.1 Description

Power Modules are designed for single drives which are not capable of regenerating energy to the supply. Generated energy produced during braking is converted to heat in braking resistors.

Power Modules of the Blocksize format contain:



- Output inverter for the supply of a motor
- Braking chopper for (external) braking resistor
- 24 VDC / 1 A power supply
- Fan to cool the power semiconductors
- Power Modules PM240-2 FSD and FSE have integrated DC link reactors and therefore do not need a line reactor.

The FSA to FSE Power Modules cover the power range from 0.55 kW to 55 kW and are available in versions with and without a line filter.

The PM240-2 Power Modules are designed for installation in the cabinet and in the following cooling variants:

- Built-in unit with internal air cooling
- Push-through unit with external air cooling (only frame sizes FSA - FSC)

Table 4- 1 Overview of PM240-2 Power Modules (selection)

	
<p>Power Module frame size FSA, with and without an integrated line filter</p>	<p>Push Through Power Module frame size FSA, with and without an integrated line filter</p>

4.1 Description

	
<p>Power Module frame size FSB, with and without integrated line filter</p>	<p>Push Through Power Module frame size FSB, with and without an integrated line filter</p>
	
<p>Power Module frame size FSC, with and without integrated line filter</p>	<p>Push Through Power Module frame size FSC, with and without an integrated line filter</p>
	
<p>Power Module frame size FSD with and without an integrated line filter</p>	<p>Push Through Power Module frame size FSD with and without an integrated line filter</p>

	
<p>Power Module frame size FSE with and without an integrated line filter</p>	

4.2 Safety instructions for Blocksize Power Modules (PM240-2)

 **WARNING**

Danger to life if the fundamental safety instructions and residual risks are not heeded

Failure to heed the fundamental safety instructions and residual risks in Chapter 1 can result in accidents causing severe injuries or death.

- Follow the fundamental safety instructions.
- Consider the residual risks on the risk assessment.



 **DANGER**

Danger to life due to electric shock caused by residual charge of the DC-link capacitors

Due to the DC link capacitors, a hazardous voltage is present in the DC link for up to 5 minutes after the power supply has been switched off.

Touching live components results in death or severe injury.

- Only carry out work on these components after this time has elapsed.
- Measure the voltage before starting work on the DCP and DCN DC-link terminals.



 **WARNING**

Danger to life due to hazardous voltage when an unsuitable power supply is connected

Death or serious injury can result when live parts are touched in the event of a fault.

- Only use the intended supply voltage to operate the Power Modules.



! WARNING

Danger to life caused by high leakage currents when the external PE conductor is interrupted

Drive components conduct high leakage currents through the PE conductor. When the PE conductor is interrupted, touching live components can result in electric shock, which can lead to death or serious injuries.

- Ensure that the external PE conductor complies with at least one of the following conditions:
 - It is laid protected against mechanical damage.¹⁾
 - If it consists of a single conductor, it has a cross section of at least 6 mm² Cu.
 - As a core of a multi-core cable, it has a cross section of at least 2.5 mm² Cu.
 - It has a parallel, second PE conductor with the same cross section.
 - It complies with the local regulations for equipment with increased leakage current.
- ¹⁾ Cables routed in control cabinets or enclosed machine enclosures are considered to be adequately protected against mechanical damage.

! WARNING

Danger of fire due to overheating if improperly installed

Improper installation can result in overheating with a hazard to persons due to smoke and fire. Further, increased failures can occur and the service life of units/systems may be shortened.

- Always install the Power Modules vertical with the line and motor connections below.
- Ensure a 1-mm clearance between mounted components.
- Ensure the following ventilation clearances above and below the component:
 - For Power Modules PM240-2 FSA, FSB, and FSC:
 - Above: 80 mm (3.15 inch)
 - Below: 100 mm (3.94 inch)
 - For Power Modules PM240-2 FSD and FSE:
 - Above: 300 mm (11.81 inch)
 - Below: 350 mm (13.78 inch)
 - Front: 100 mm (3.94 inch)
- Only install devices in this area that do not obstruct the flow of cooling air.
- Ensure that the cooling air can flow through the Power Modules unobstructed.

NOTICE

Material damage caused by loose power connections

Insufficient tightening torques or vibration can result in faulty electrical connections. This can cause fire damage or functional faults.

- Tighten all power connections with the specified tightening torques, e.g. line supply connection, motor connection, DC-link connections.
- Check the tightening torques of all power connections at regular intervals and tighten them when required. This applies in particular after transport.
- In the case of plug-in power terminals, check that the interlock of the connectors on the converter housing is intact.

Note

Malfunctions on non-Siemens equipment caused by high-frequency faults in residential environments

In the first environment, Category C2 according to EMC product standard IEC 61800-3 (residential, commercial and industrial sector), the device may cause high-frequency disturbance, which can result in malfunctions in other equipment.

- Have the installation and commissioning with appropriate radio interference suppression measures performed by qualified personnel.

Note

Connection approval for Power Modules ≤ 16 A per conductor

Power Modules have been designed for use in the industrial environment and generate current harmonics on the line side as a result of the rectifier circuit.

Machines with built-in Power Modules ≤ 16 A per conductor must meet the current harmonics requirements of EN 61000-3-2 to be connected to the public low-voltage power system.

If they do not, a connection approval must be applied for from the competent power utility.

Note

For a UL-approved system use UL-approved cables only.

4.3 Interface description

4.3.1 Overview

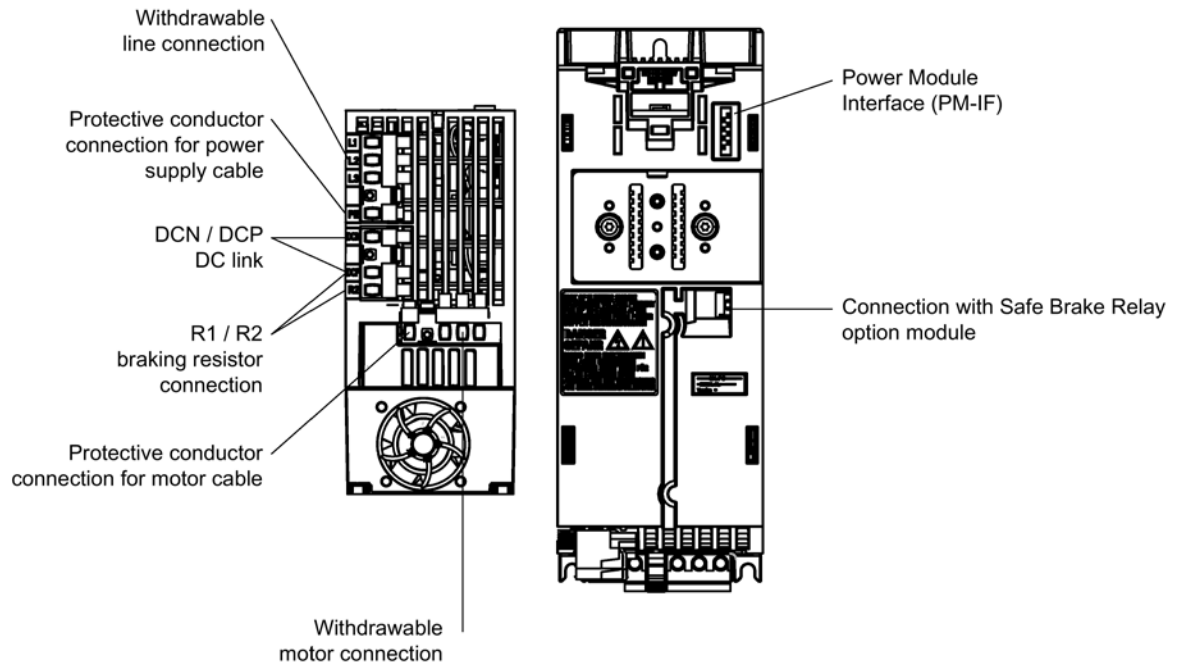

Figure 4-1 PM240-2, frame size FSA (view from below and front)

4.3 Interface description

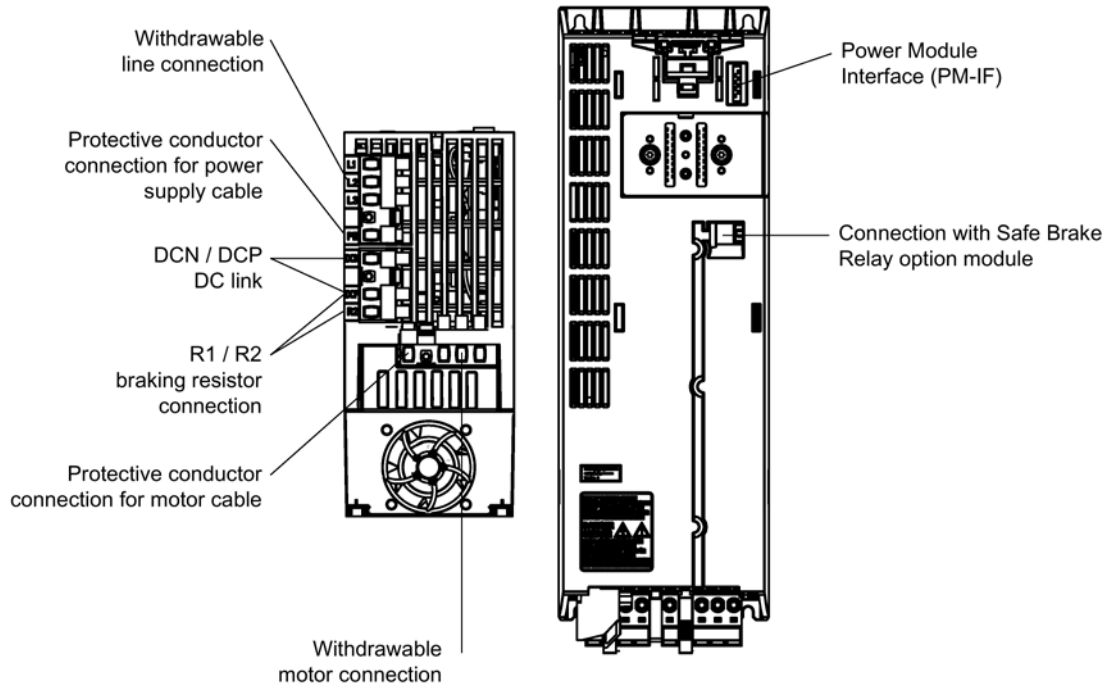

Figure 4-2 PM240-2, frame size FSB (view from below and front)

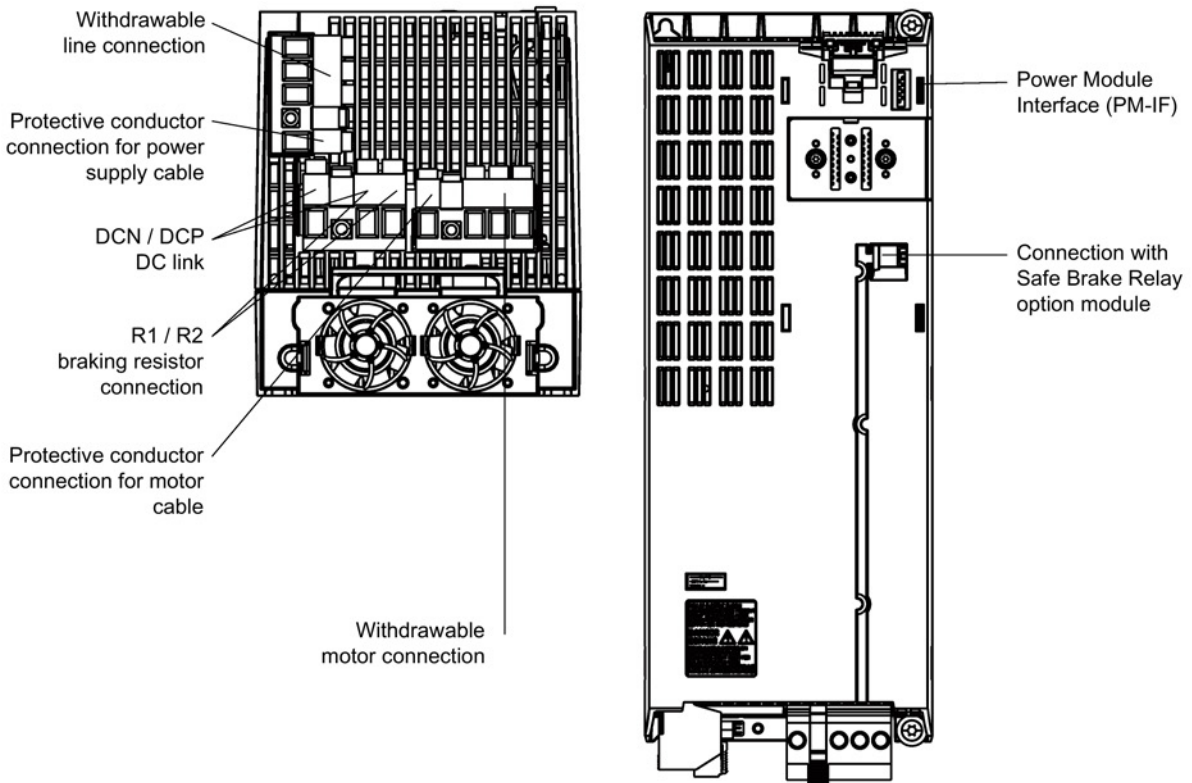

Figure 4-3 PM240-2, frame size FSC (view from below and front)

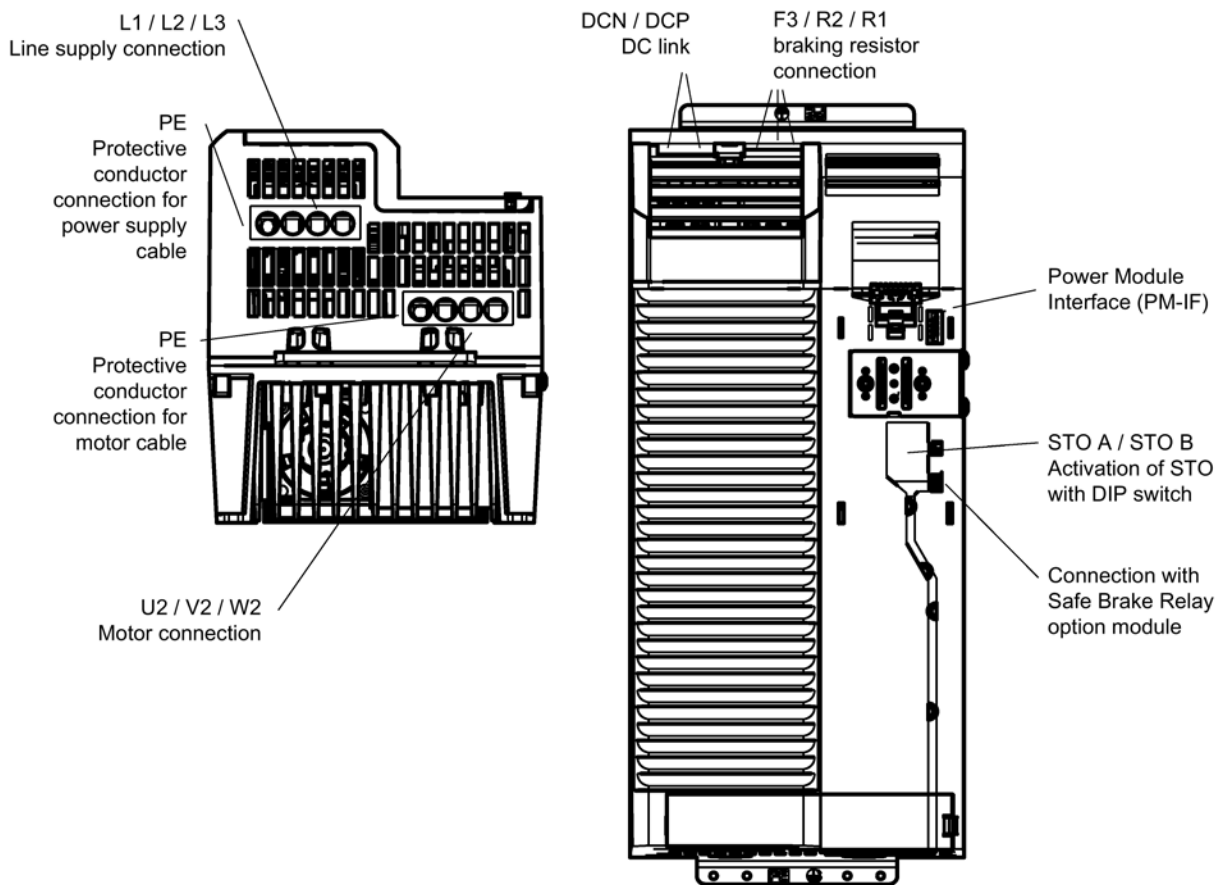

Figure 4-4 PM240-2, frame size FSD (view from below and front)

Note

Use of the safety function "STO" via PM terminals with SINAMICS S110

With enabled Safety Integrated functions of the CU305, a simultaneously active STO function via PM terminals causes error messages to be output (see Chapter STO connection via PM terminals (Page 82)).

4.3 Interface description

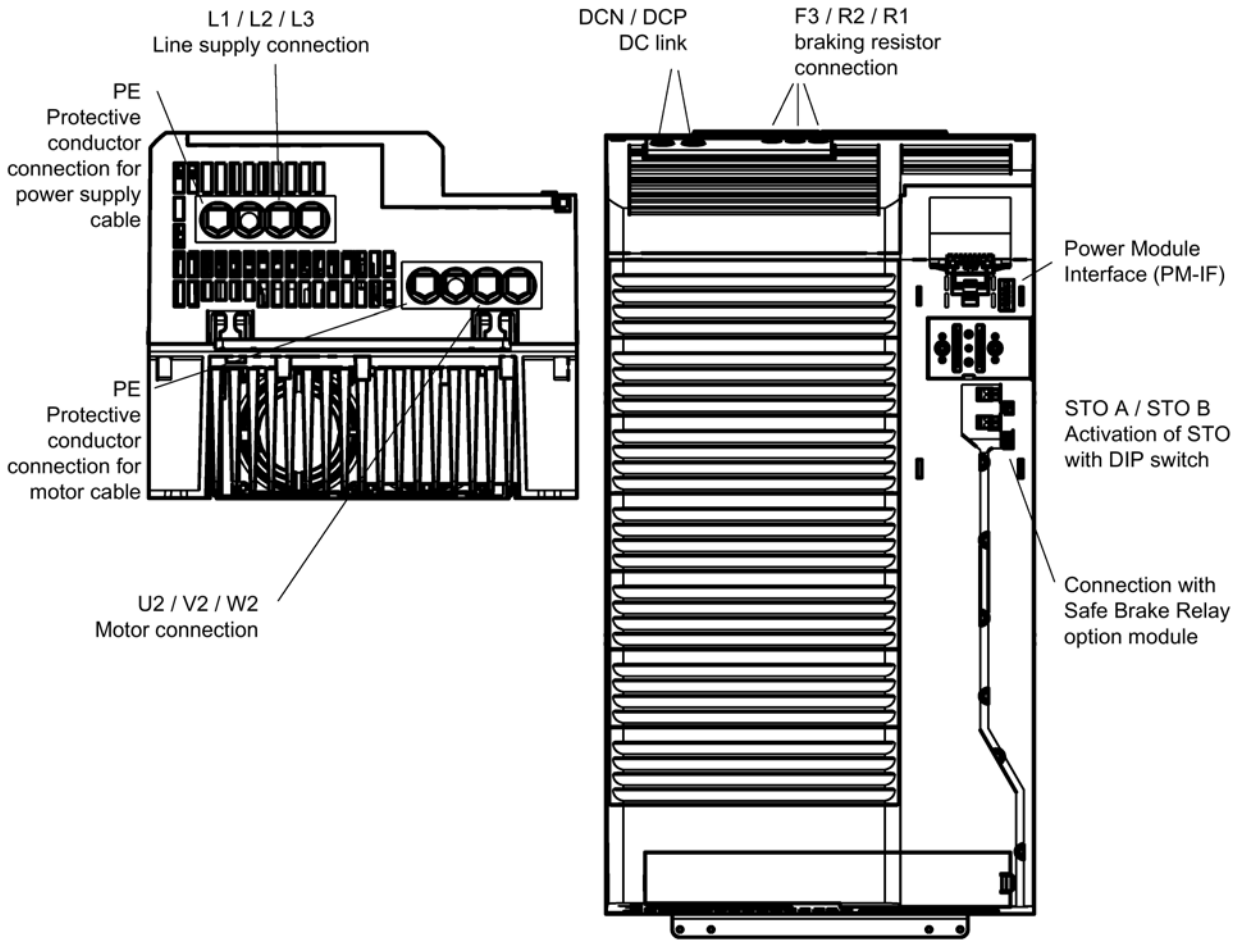

Figure 4-5 PM240-2, frame size FSE (view from below and front)

Note

Use of the safety function "STO" via PM terminals with SINAMICS S110

With enabled Safety Integrated functions of the CU305, a simultaneously active STO function via PM terminals causes error messages to be output (see Chapter STO connection via PM terminals (Page 82)).

4.3.2 Connection example

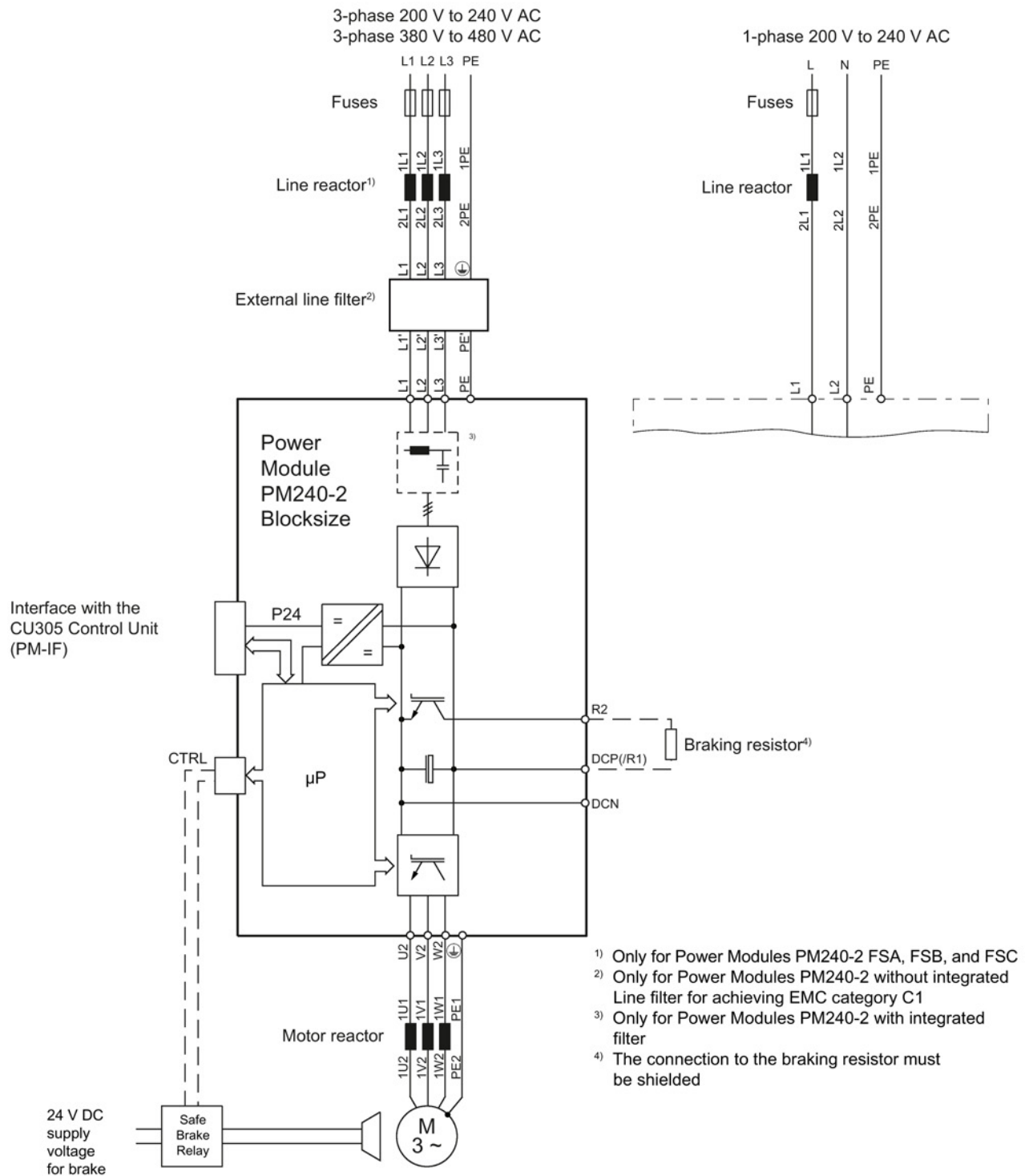

Figure 4-6 Connection example Power Modules PM240-2 (for FSA to FSC)

4.3 Interface description

Note

Connection of PM240-2, FSD and FSE, without line reactors

Because Power Modules PM240-2, FSD and FSE, contain integrated DC link reactors, line reactors do not need to be connected on the line side.

4.3.3 Line supply connection

Power Modules PM240-2: FSA, FSB, and FSC

Table 4- 2 Removable line connector

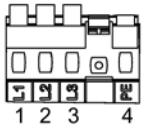
	Terminal	Signal name	Technical data
	1	L1	Line conductor L1
	2	L2	Line conductor L2
	3	L3	Line conductor L3
	4	PE	PE connection

Power Modules PM240-2: FSD and FSE

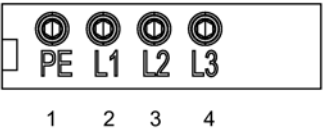
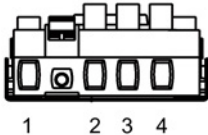

Table 4- 3 Line supply connection terminal

	Terminals	Signal name	Technical data
	1	PE	PE connection
	2	L1	Line conductor L1
	3	L2	Line conductor L2
	4	L3	Line conductor L3

4.3.4 Motor connection

Power Modules PM240-2: FSA, FSB, and FSC

Table 4- 4 Removable motor connector

	Terminal	Signal name	Technical data
	1		PE connection
	2	U2	Motor phase U
	3	V2	Motor phase V
	4	W2	Motor phase W

Power Modules PM240-2: FSD and FSE

Table 4- 5 Motor terminals

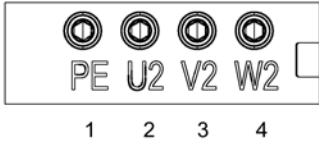
	Terminal	Signal name	Technical data
	1	PE	PE connection
	2	U2	Motor phase U
	3	V2	Motor phase V
	4	W2	Motor phase W

4.3.5 Braking resistor and DC link connection

Power Modules PM240-2: FSA, FSB, and FSC

Table 4- 6 Removable braking resistor and DC link connector

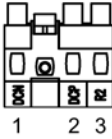
	Terminal	Signal name	Technical data
	1	DCN	DC link negative
	2	DCP/R1	DC link positive and positive connection for braking resistor
	3	R2	Negative connection for the braking resistor

Power Modules PM240-2: FSD

Table 4- 7 DC link terminals

	Terminal	Signal name	Technical data
	1	DCN	DC link negative
	2	DCP	DC link positive

Table 4- 8 Braking resistance terminals

	Terminal	Signal name	Technical data
	1	F3	currently not assigned
	2	R2	negative connection for the braking resistor
	3	R1	positive connection for braking resistor

Power Modules PM240-2: FSE

Table 4- 9 DC link terminals

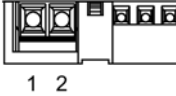
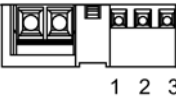
	Terminal	Signal name	Technical data
	1	DCN	DC link negative
	2	DCP	DC link positive

Table 4- 10 Braking resistance terminals

	Terminal	Signal name	Technical data
	1	F3	currently not assigned
	2	R2	negative connection for the braking resistor
	3	R1	positive connection for braking resistor

4.3.6 Safe Brake Relay connection

Table 4- 11 Connector

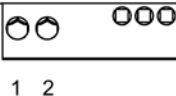
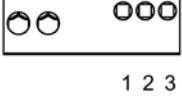
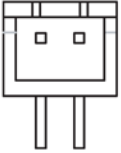
	Terminal	Designation	Technical data
	1	Low	Low signal Safe Brake Relay to PM240-2
	2	High	High signal Safe Brake Relay to PM240-2

Note

You will find more information in Chapter Option module Safe Brake Relay (Page 208).

4.3.7 STO connection via PM terminals

Power Modules PM240-2: FSD and FSE

Via the safety function "Safe Torque Off" (STO), the torque producing energy input to the motor can be safely interrupted.

For the Power Modules PM240-2 with frame sizes FSD and FSE, this functionality can be implemented in the hardware via the PM terminals STO_A/STO_B.

However, with SINAMICS S110, "Safe Torque Off" via PM terminals can only be used if the Safety Integrated functions of the CU305 are deactivated.

Table 4- 12 Terminals STO_A/STO_B for the safety function "Safe Torque Off"

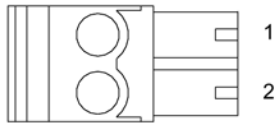
	Terminal	Signal name	Technical data
Terminal: 	1	STO_A/STO_B	Voltage: 24 V DC (20.4 to 28.8 V) Current consumption: Max. 1.0 A
	2	M	Ground
Type: Screw-type terminal 2 (Page 263) Max. cross section that can be connected: 2.5 mm ² Max. cable length: 30 m (only shielded cables may be used)			

Note

Use of the safety function "STO" via PM terminals with SINAMICS S110

With enabled Safety Integrated functions of the CU305, a simultaneously active STO function via PM terminals causes output of error messages.

Table 4- 13 DIP switches for the safety function "Safe Torque Off" via PM terminals

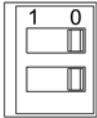
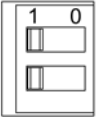
DIP switch	Application
	To use Safety Integrated of the CU305, deactivate the function "STO via PM terminals" by putting both the DIP switches for the interface STO_A/STO_B into the "0" position.
	To be able to use the "STO via PM terminals" function, deactivate Safety Integrated in the by putting both the CU305 (parameter p9601=0) and put both DIP switches for the interface STO_A/STO_B into the "1" position.

4.4 Dimension drawings

4.4.1 Dimension drawings PM240-2

Power Modules with internal air cooling

Table 4- 14 Dimensions of the Power Modules, including the shield connection plates

Frame size	Width [mm]	Height [mm]				Depth [mm]
		Power Module	Shield plate at the top	Shield plate at the bottom	Total	
FSA	73	196	-	80	276	165
FSB	100	291	-	79	370	165
FSC	140	355	-	77	432	165
FSD	200	472	83.5	152	707.5	237
FSE	275	550	122.5	177	849.5	237

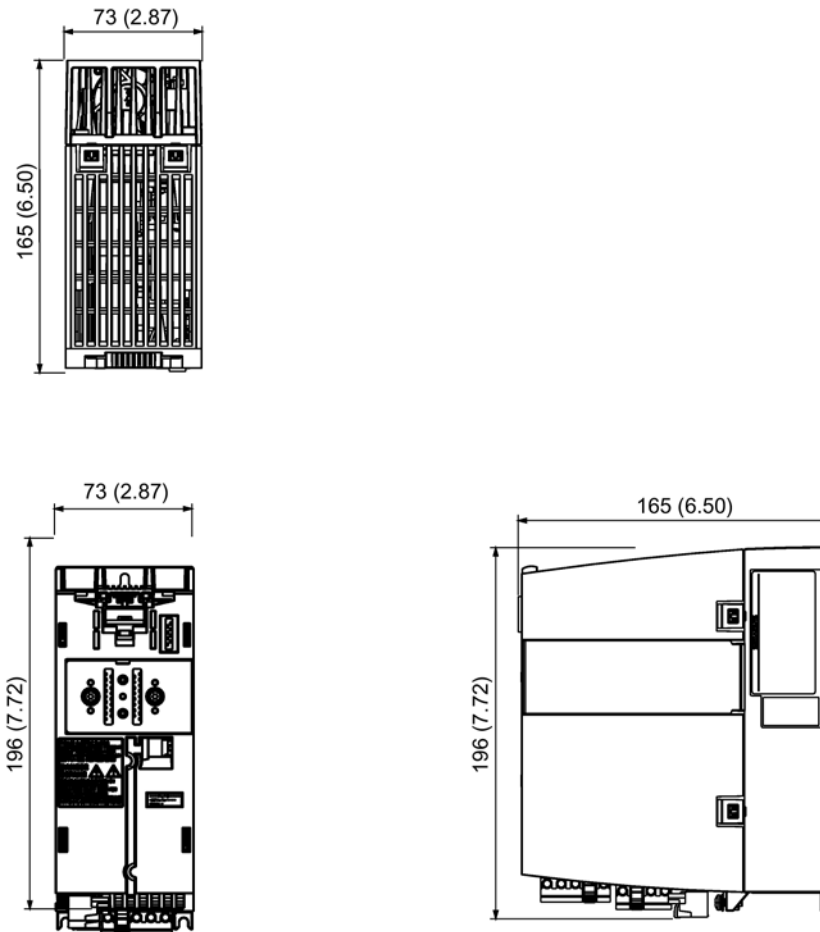

Figure 4-7 Dimension drawing of PM240-2 Power Modules, frame size FSA, all data in mm (inches)

4.4 Dimension drawings

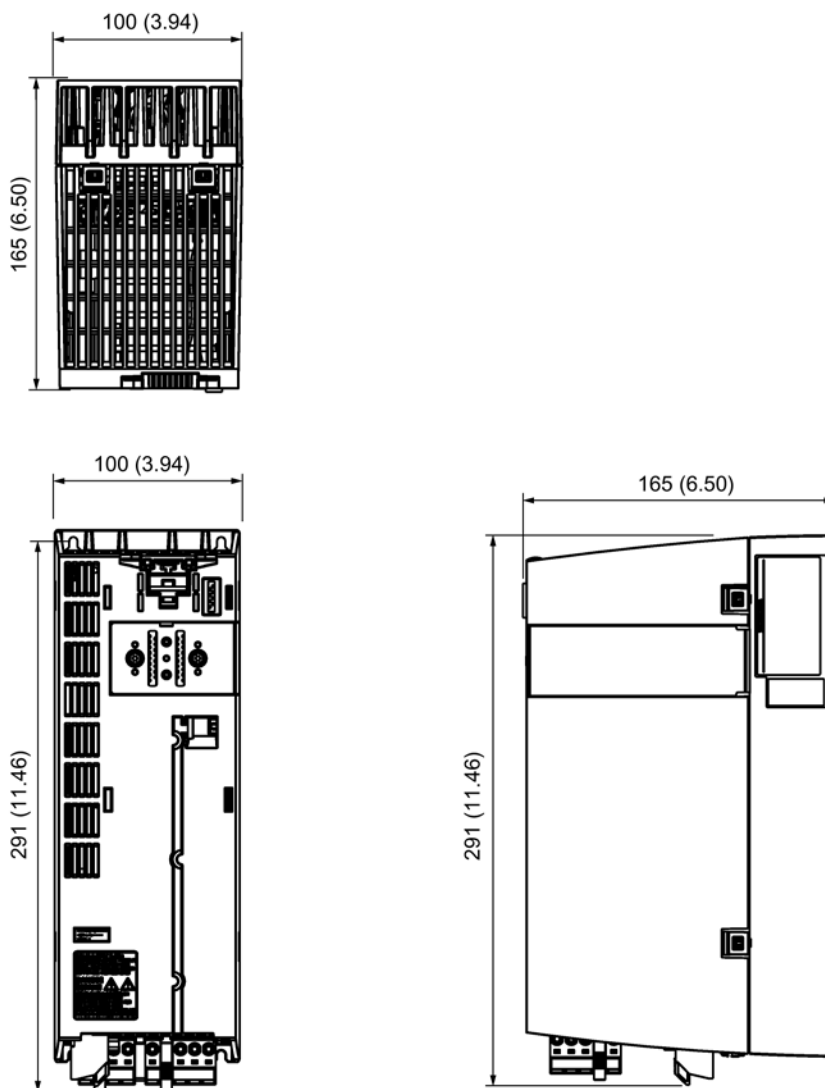

Figure 4-8 Dimension drawing of PM240-2 Power Modules, frame size FSB, all data in mm (inches)

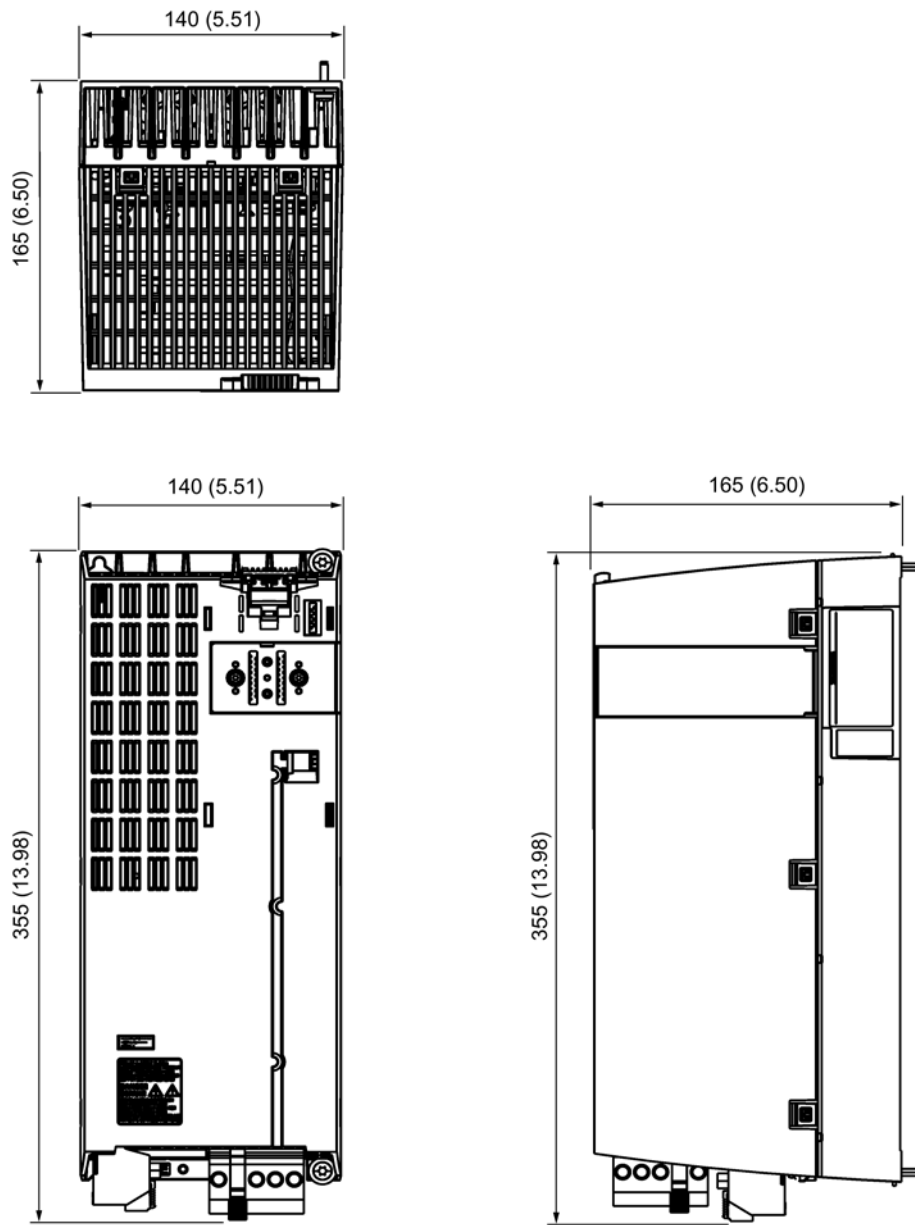

Figure 4-9 Dimension drawing of PM240-2 Power Modules, frame size FSC, all data in mm (inches)

4.4 Dimension drawings

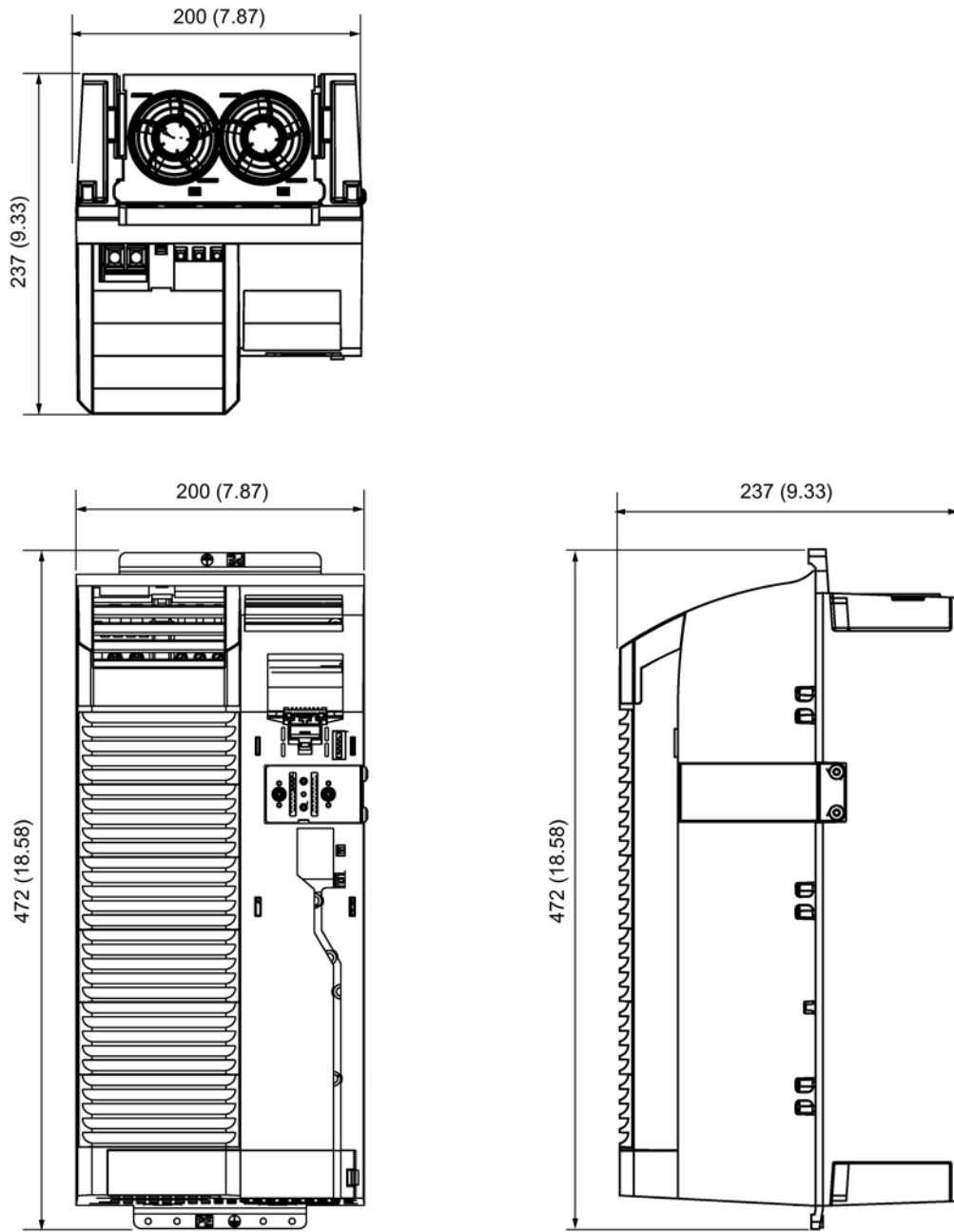

Figure 4-10 Dimension drawing of PM240-2 Power Modules, frame size FSD, all data in mm (inches)

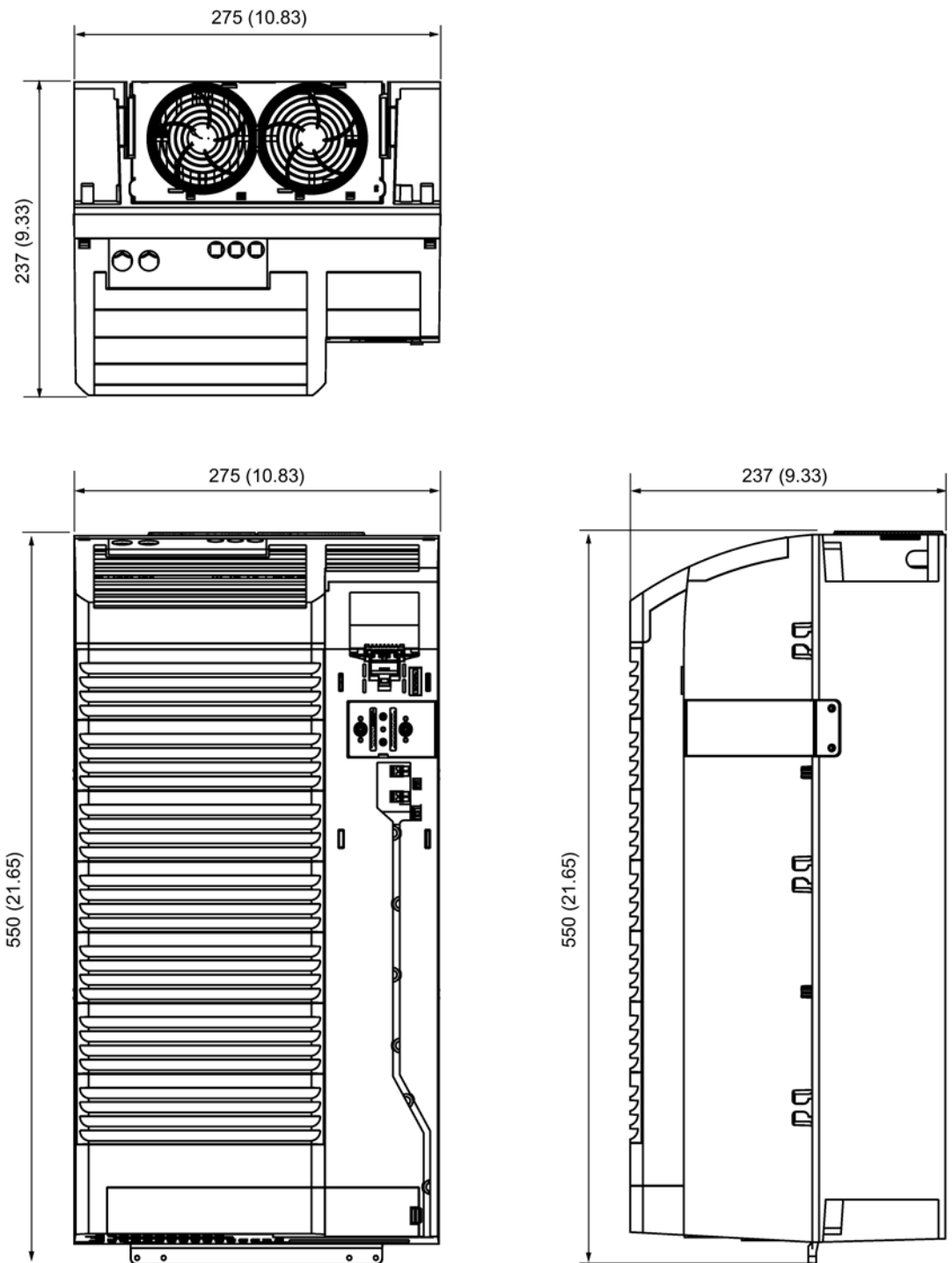

Figure 4-11 Dimension drawing of PM240-2 Power Modules, frame size FSE, all data in mm (inches)

Power Modules, Push Through for frame sizes FSA / FSB / FSC

Table 4- 15 Dimensions of the Power Modules

Frame size	Width ¹⁾ [mm]	Height [mm]		Total depth ²⁾ [mm]	Depth in the cabinet [mm]	Depth outside the cabinet [mm]
		None Shield plate	with Shield plate			
FSA	126	238	322	171	117.7	53.1
FSB	154	345	430	171	117.7	53.1
FSC	200	411	500	171	117.7	53.1

1) The Power Modules can be mounted side by side. For tolerance reasons, we recommend a lateral clearance of 1 mm.

2) For PT modules, the maximum wall thickness of the cabinet is 3.5 mm.

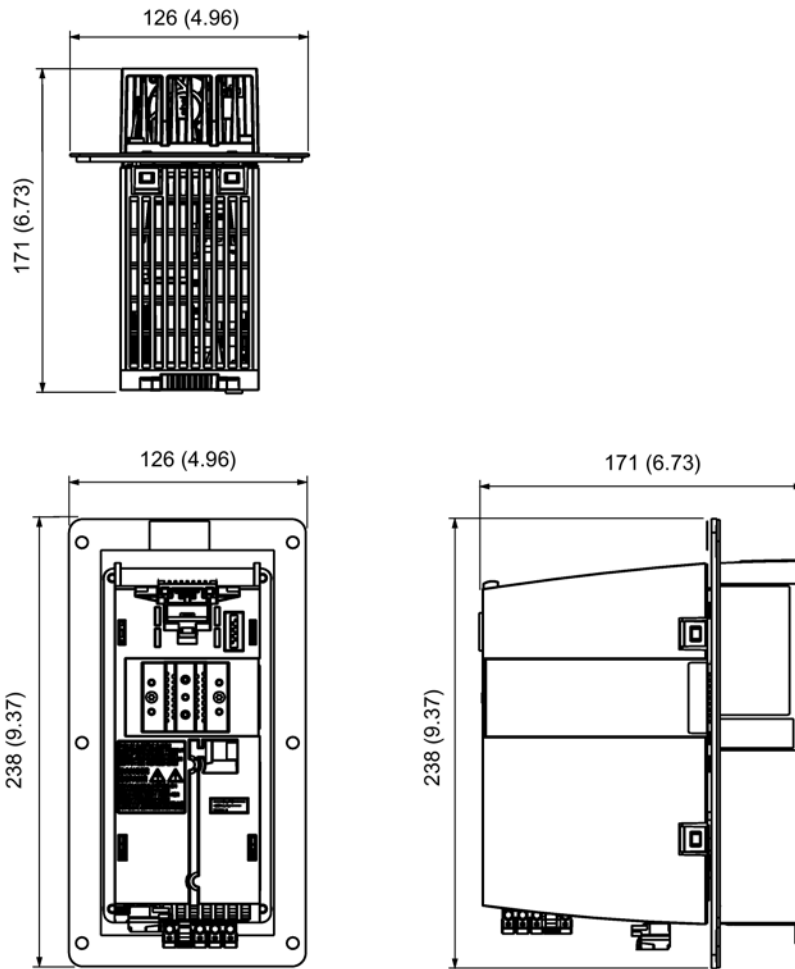

Figure 4-12 Dimension drawing of PM240-2 Push Through Power Modules, frame size FSA, all data in mm (inches)

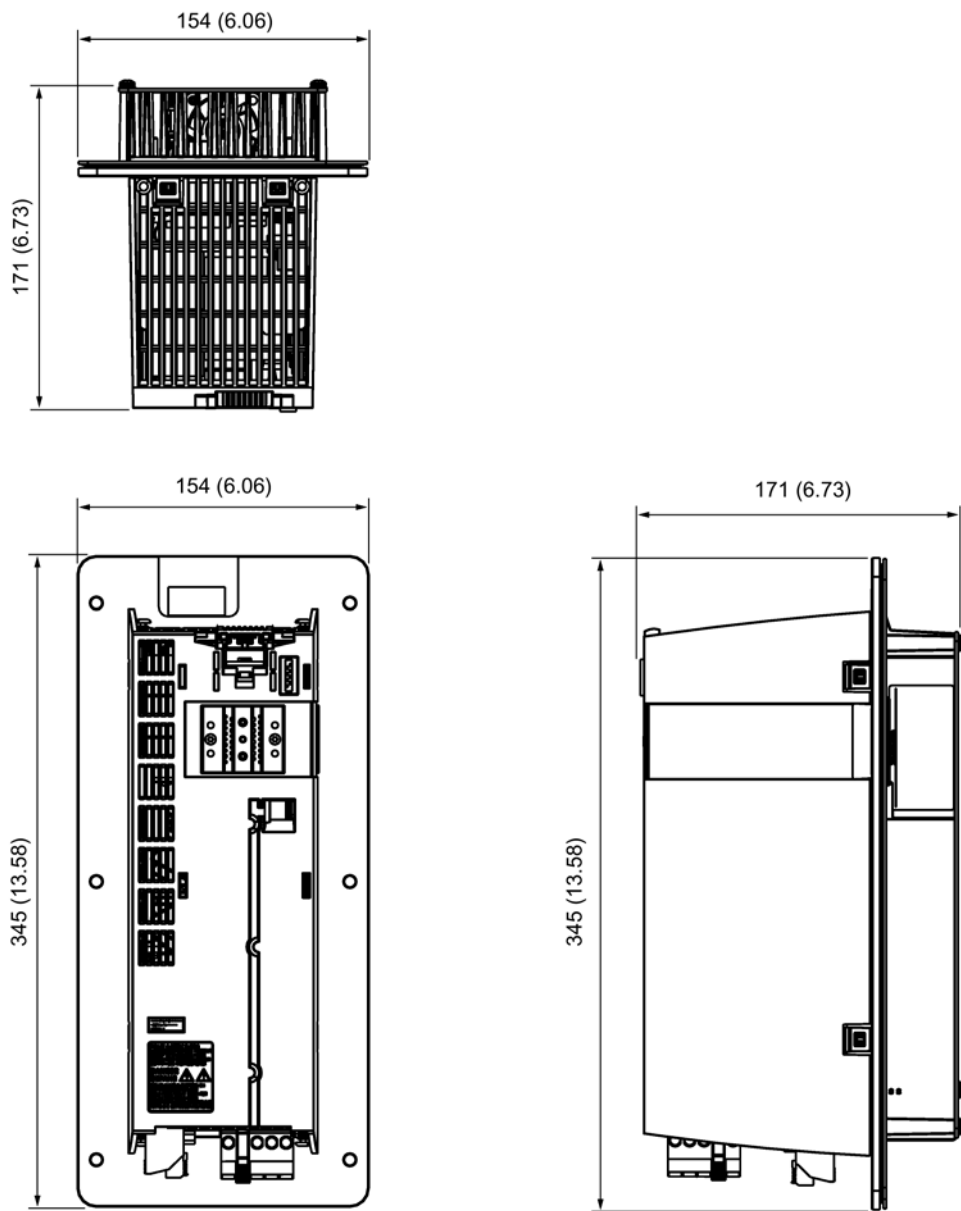

Figure 4-13 Dimension drawing of PM240-2 Push Through Power Modules, frame size FSB, all data in mm (inches)

4.4 Dimension drawings

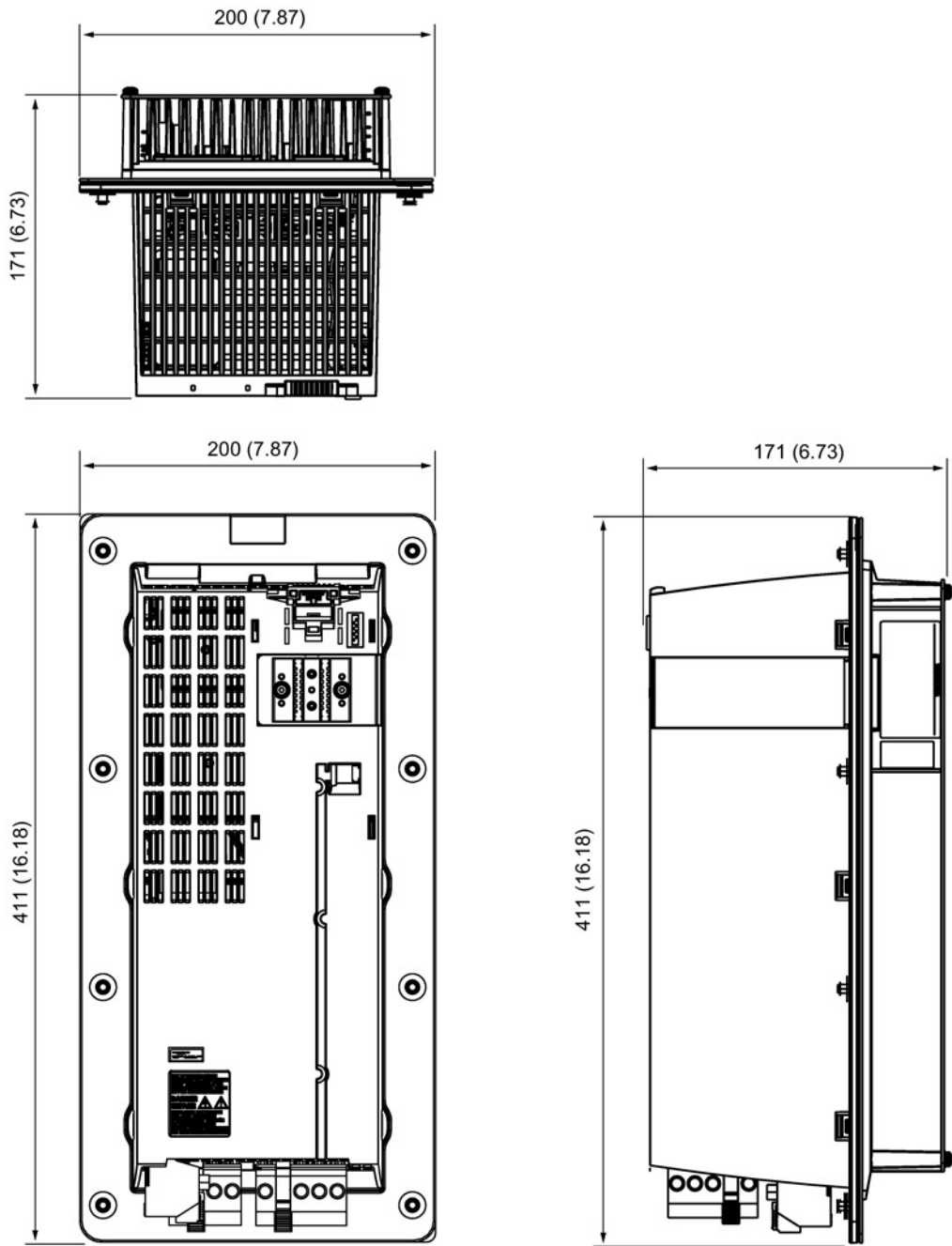

Figure 4-14 Dimension drawing of PM240-2 Push Through Power Modules, frame size FSC, all data in mm (inches)

4.4.2 Drilling patterns

Power Modules frame sizes FSA / FSB / FSC

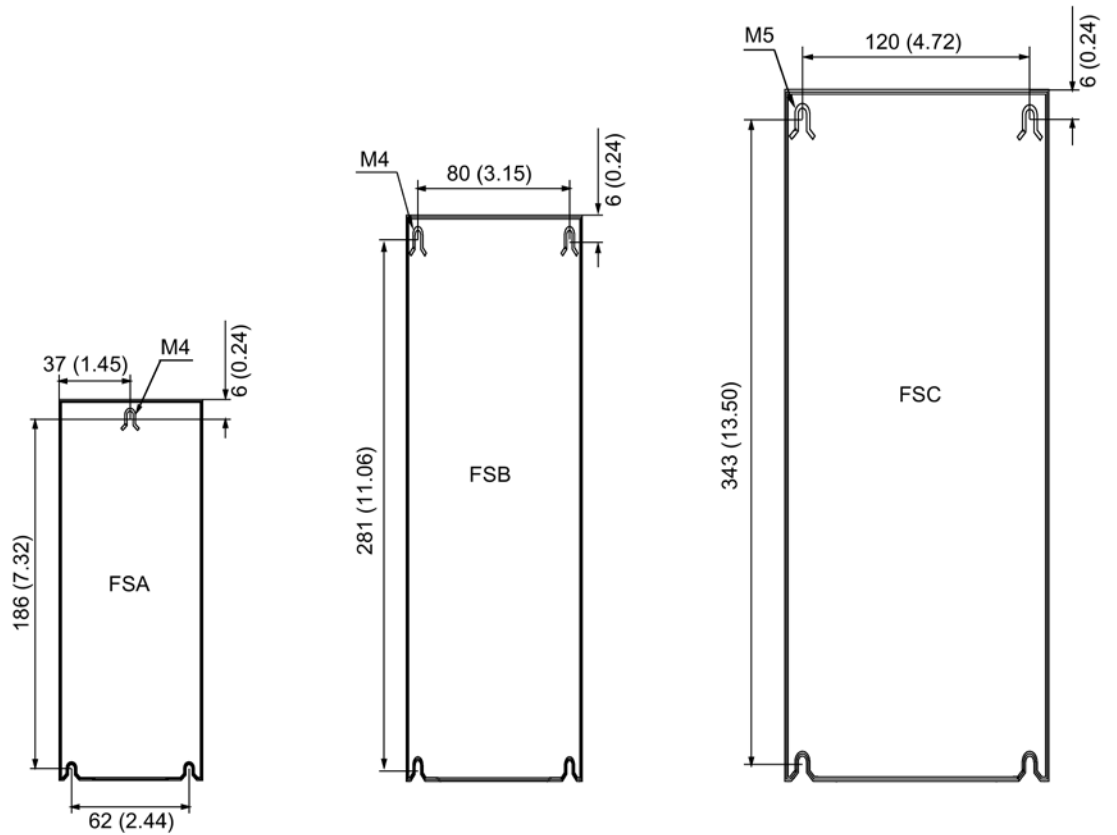

Figure 4-15 Drilling patterns of PM240-2 Power Modules, frame sizes FSA, FSB, FSC; all data in mm and (inches)

Power Modules, frame sizes FSD / FSE

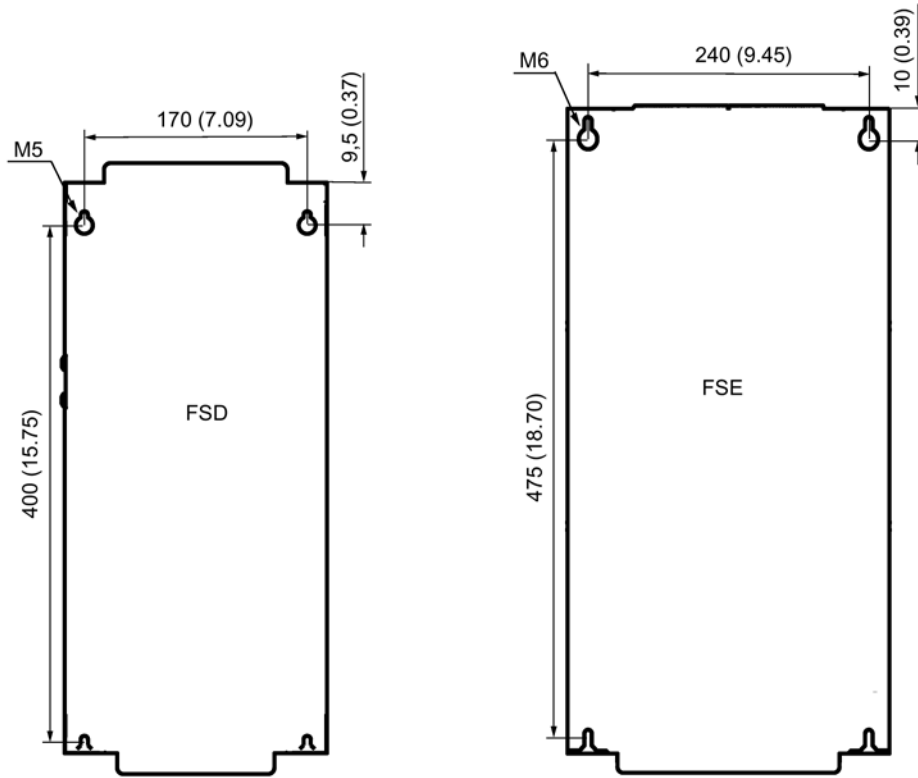

Figure 4-16 Drilling patterns of PM240-2 Power Modules, frame sizes FSD, FSE; all data in mm and (inches)

Power Modules, Push Through, frame sizes FSA / FSB / FSC

Drilling patterns for Power Modules, Push Through, FSA - FSC, see Chapter Mounting rack/dimension drawings.

4.5 Mounting

4.5.1 Mounting instructions

Note

Mounting instructions

- Please refer to the notes for installing Power Modules in Section Safety instructions for Blocksize Power Modules (PM240-2) (Page 70).
 - You must mount the PM240-2 Push Through Power Modules on an unpainted metal surface in order to comply with EMC requirements.
 - To be able to mount PM240-2 Push Through Power Modules, the wall thickness of the cabinet must be ≤ 3.5 mm.
-

Note

Installation frame for push through units

An installation frame should be used when push through units are installed in the cabinet. You can find more information about the installation frame in Section Mounting frame (Page 222).

This mounting frame includes the necessary seals and frame to ensure compliance with degree of protection IP54.

If you do not use the mounting frames, you must ensure that the required degree of protection is complied with using other appropriate measures.

4.5 Mounting

4.5.2 Mounting dimensions and tightening torques

The mounting dimensions and the tightening torques for fixing the Power Modules are specified in the following table.

Table 4- 16 PM240-2 Power Modules, dimensions and tightening torques for mounting

Frame size		Height, width, depth		Fastening	Tightening torque
		Without shield connection plate	With shield connection plate		
FSA	mm	196 x 73 x 165	276 x 73 x 165	3 x M4 studs, 3 x M4 nuts, 3 x M4 washers	2.5 Nm with washers inserted
	Inch	7.72 x 2.87 x 6.50	10.87 x 2.87 x 6.50		
FSB	mm	291 x 100 x 165	370 x 100 x 165	4 x M4 studs, 4 x M4 nuts, 4 x M4 washers	2.5 Nm with washers inserted
	Inch	11.46 x 3.94 x 6.50	14.57 x 9.94 x 6.50		
FSC	mm	355 x 140 x 165	409 x 140 x 165	4 x M5 studs, 4 x M5 nuts, 4 x M5 washers	3.0 Nm with washers inserted
	Inch	13.98 x 5.51 x 6.50	16.10 x 5.51 x 6.50		
FSD	mm	470 x 200 x 237	707.5 x 200 x 237	4 x M5 studs, 4 x M5 nuts, 4 x M5 washers	6.0 Nm with washers inserted
	inch	18.50 x 7.87 x 9.33	27.85 x 7.87 x 9.33		
FSE	mm	550 x 275 x 237	850 x 275 x 237	4 x M6 studs, 4 x M6 nuts, 4 x M6 washers	10.0 Nm with washers inserted
	inch	21.65 x 10.83 x 9.33	33.46 x 10.83 x 9.33		

Table 4- 17 PM240-2 Power Modules Push Through, dimensions and tightening torques for mounting

Frame size		Height, width, depth		Fastening	Tightening torque
		Without shield connection plate	With shield connection plate		
FSA	mm	238 x 126 x 171	322 x 126 x 171	6 x M5 studs, 6 x M5 nuts, 6 x M5 washers	3.5 Nm with washers inserted
	Inch	9.37 x 4.96 x 6.73	12.68 x 4.96 x 6.73		
FSB	mm	345 x 154 x 171	430 x 154 x 171	8 x M5 studs, 8 x M5 nuts, 8 x M5 washers	3.5 Nm with washers inserted
	Inch	13.58 x 6.06 x 6.73	16.93 x 6.06 x 6.73		
FSC	mm	411 x 200 x 171	500 x 200 x 171	8 x M5 studs, 8 x M5 nuts, 8 x M5 washers	3.5 Nm with washers inserted
	Inch	16.18 x 7.87 x 6.73	19.69 x 7.87 x 6.73		

4.5.3 Mounting the shield connection plate

The shield connection plate is used to connect the shields of the two power cables.

Tools required:

- Torx screwdriver T20

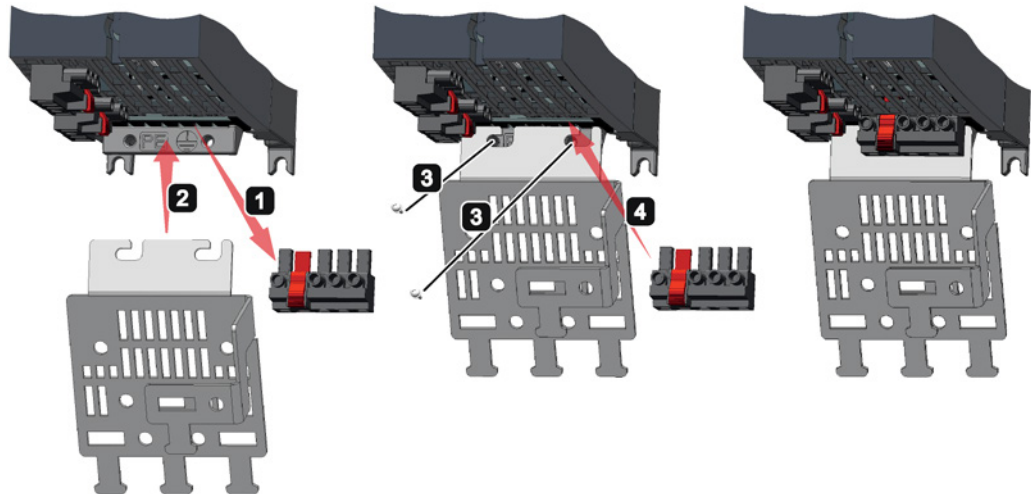

Figure 4-17 Mounting the shield connection plate on Power Modules PM240-2 FSA, FSB, and FSC

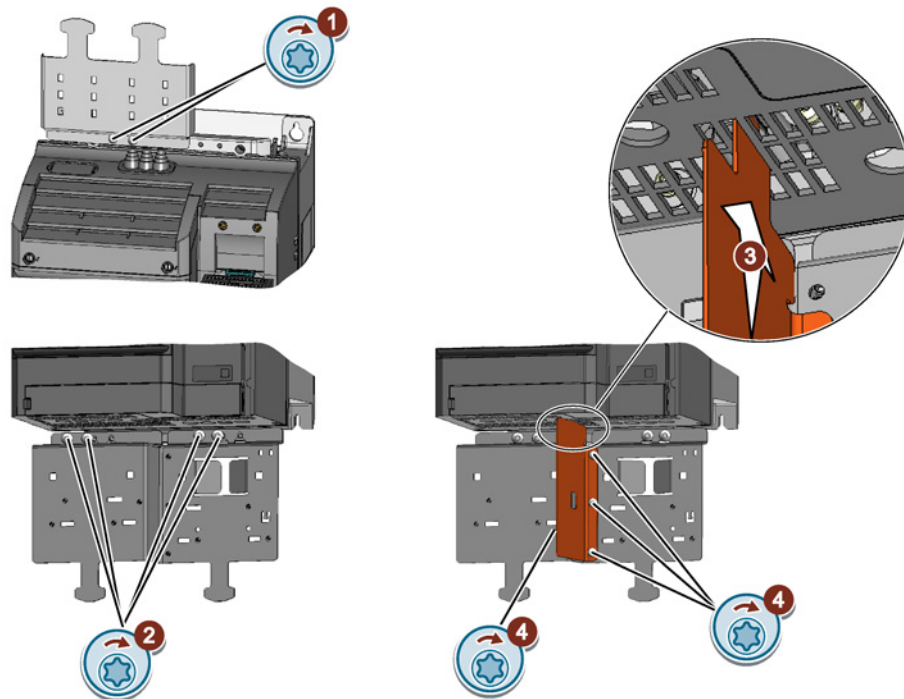

Figure 4-18 Mounting the shield connection plate on Power Modules PM240-2 FSD and FSE

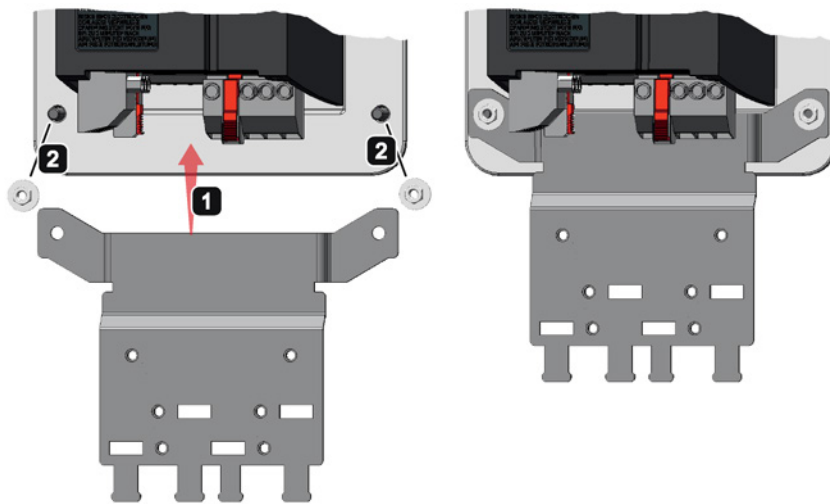

Figure 4-19 Mounting the shield connection plate on Power Modules PM240-2 Push Through FSA, FSB, and FSC

4.6 Technical data

4.6.1 Note about degree of protection

Note

Degree of protection of PM240-2 Power Modules

The Power Modules PM240-2 fulfill degree of protection IP20 per EN 60529.

When Push Through Power Modules are installed in a cabinet with degree of protection IP54 or IP55 using a suitable mounting frame and seals, the Power Modules also comply with this degree of protection.

According to UL, the Power Modules meet the requirements for an open type component, external type 12.

4.6.2 200 V Power Modules

Table 4- 18 Technical data of the PM240-2, FSA (200 V)

Line voltage 1/3 AC 200 ... 240 V \pm 10 %				
		Internal		Push-through
Article No. without integrated line filter with integrated line filter		6SL3210– 1PB13-0UL0 1PB13-0AL0	6SL3210– 1PB13-8UL0 1PB13-8AL0	6SL3211– 1PB13-8UL0 1PB13-8AL0
Output current				
Rated current I_n	A	3.0	3.9	3.9
Base-load current I_H	A	2.3	3.0	3.0
for S6 operation (40%) I_{S6}	A	3.3	4.3	4.3
Peak current I_{max}	A	4.6	6.0	6.0
Unit rating ¹⁾				
on basis of I_n	kW	0.55	0.75	0.75
on basis of I_H	kW	0.37	0.55	0.55
Rated pulse frequency	kHz	4	4	4
Max. Pulse frequency	kHz	16	16	16
Power loss	kW	0.04	0.04	0.04 ⁴⁾
Cooling air requirement	l/s	5	5	5
Sound pressure level LpA (1 m)	dB	49.2	49.2	49.2
24 V DC supply for the Control Unit	A	1.0	1.0	1.0
Rated input current ²⁾	A	7.5	9.6	9.6
Resistance value of the external braking resistor	Ω	≥ 200	≥ 200	≥ 200
Max. Cable length to the braking resistor	m	15	15	15
Line supply connection L1, L2, PE		Screw-type terminals		
Motor connection U2, V2, W2 \oplus		Cross head M2.5		
DC-link connection, connection for braking resistor DCP/R1, DCN, R2		Conductor cross section: 1.5 ... 2.5 mm ² Tightening torque: 0.5 Nm		
Max. Motor cable length ³⁾ shielded / unshielded	m	50 / 100		
Degree of protection		IP20		in the cabinet: IP20 outside: IP54
Weight				
Without line filter	kg	1.4	1.4	1.8
With line filter	kg	1.6	1.6	2.0

1) Rated output of a typical standard induction motor at 230 V.

2) The input current depends on the motor load and line impedance. The input currents apply for a load with the type rating (based on I_{rated}) for a line impedance corresponding to $u_k = 1\%$.

3) To observe the limit values of EN 61800-3 category C2, for Power Modules PM240-2 with integrated line filter 50 m (shielded) is the max. motor cable length. A cable length up to 150 m is possible for C2 if you use an unfiltered Power Module with an external line filter class B and a motor reactor.

4) Power loss in the cabinet: 0.02 kW. The remaining power loss is dissipated through the heat sink.

4.6 Technical data

Table 4- 19 Technical data of the PM240-2, FSB (200 V)

Line voltage 1/3 AC 200 ... 240 V ± 10 %					
		Internal			Push-through
Article No. without integrated line filter with integrated line filter		6SL3210- 1PB15-5UL0 1PB15-5AL0	6SL3210- 1PB17-4UL0 1PB17-4AL0	6SL3210- 1PB21-0UL0 1PB21-0AL0	6SL3211- 1PB21-0UL0 1PB21-0AL0
Output current					
Rated current I _n	A	5.5	7.4	10.4	10.4
Base-load current I _H	A	3.9	5.5	7.4	7.4
for S6 operation (40%) I _{s6}	A	6.1	8.2	11.5	11.5
Peak current I _{max}	A	8.3	11.1	15.6	15.6
Unit rating ¹⁾					
on basis of I _n	kW	1.1	1.5	2.2	2.2
on basis of I _H	kW	0.75	1.1	1.5	1.5
Rated pulse frequency	kHz	4	4	4	4
Max. Pulse frequency	kHz	16	16	16	16
Power loss	kW	0.05	0.07	0.12	0.12 ⁴⁾
Cooling air requirement	l/s	9.2	9.2	9.2	9.2
Sound pressure level LpA (1 m)	dB	61.5	61.5	61.5	61.5
24 V DC supply for the Control Unit	A	1.0	1.0	1.0	1.0
Rated input current ²⁾	A	13.5	18.1	24.0	24.0
Resistance value of the external braking resistor	Ω	≥ 68	≥ 68	≥ 68	≥ 68
Max. Cable length to the braking resistor	m	15	15	15	15
Line supply connection L1, L2, PE		Screw-type terminals Cross head M2.5 Conductor cross section: 1.5 ... 6 mm ² Tightening torque: 0.6 Nm			
Motor connection U2, V2, W2 					
DC-link connection, connection for braking resistor DCP/R1, DCN, R2					
Max. Motor cable length ³⁾ shielded / unshielded	m	50 / 100			
Degree of protection		IP20			in the cabinet: IP20 outside: IP54
Weight					
Without line filter	kg	2.9	2.9	2.9	3.4
With line filter	kg	3.1	3.1	3.1	3.7

- 1) Rated output of a typical standard induction motor at 230 V.
- 2) The input current depends on the motor load and line impedance. The input currents apply for a load with the type rating (based on I_{rated}) for a line impedance corresponding to u_k = 1%.
- 3) To observe the limit values of EN 61800-3 category C2, for Power Modules PM240-2 with integrated line filter 50 m (shielded) is the max. motor cable length. A cable length up to 150 m is possible for C2 if you use an unfiltered Power Module with an external line filter class B and a motor reactor.
- 4) Power loss in the cabinet: 0,045 kW. The remaining power loss is dissipated through the heat sink.

Table 4- 20 Technical data of the PM240-2, FSC (200 V)

Line voltage 1/3 AC 200 ... 240 V ± 10 %				
		Internal		Push-through
Article No. without integrated line filter with integrated line filter		6SL3210– 1PB21-4UL0 1PB21-4AL0	6SL3210– 1PB21-8UL0 1PB21-8AL0	6SL3211– 1PB21-8UL0 1PB21-8AL0
Output current				
Rated current I_n	A	13.6	17.5	17.5
Base-load current I_H	A	10.4	13.6	13.6
for S6 operation (40%) I_{S6}	A	15.0	19.3	19.3
Peak current I_{max}	A	20.8	27.2	27.2
Unit rating ¹⁾				
on basis of I_n	kW	3.0	4.0	4.0
on basis of I_H	kW	2.2	3.0	3.0
Rated pulse frequency	kHz	4	4	4
Max. Pulse frequency	kHz	16	16	16
Power loss	kW	0.14	0.18	0.18 ⁴⁾
Cooling air requirement	l/s	18.5	18.5	18.5
Sound pressure level LpA (1 m)	dB	64.9	64.9	64.9
24 V DC supply for the Control Unit	A	1.0	1.0	1.0
Rated input current ²⁾	A	35.9	43.0	43.0
Resistance value of the external braking resistor	Ω	≥ 75	≥ 75	≥ 37
Max. Cable length to the braking resistor	m	15	15	15
Line supply connection L1, L2, PE		Screw-type terminals Cross head M4 Conductor cross section: 6 ... 16 mm ² Tightening torque: 1.3 Nm		
Motor connection U2, V2, W2 				
DC-link connection, connection for braking resistor DCP/R1, DCN, R2				
Max. Motor cable length ³⁾ shielded / unshielded	m	50 / 100		
Degree of protection		IP20		in the cabinet: IP20 outside: IP54
Weight				
Without line filter	kg	5.0	5.0	5.8
With line filter	kg	5.2	5.2	6.3

1) Rated output of a typical standard induction motor at 230 V.

2) The input current depends on the motor load and line impedance. The input currents apply for a load with the type rating (based on I_{rated}) for a line impedance corresponding to $u_k = 1\%$.

3) To observe the limit values of EN 61800-3 category C2, for Power Modules PM240-2 with integrated line filter 50 m (shielded) is the max. motor cable length. A cable length up to 150 m is possible for C2 if you use an unfiltered Power Module with an external line filter class B and a motor reactor.

4) Power loss in the cabinet: 0.075 kW. The remaining power loss is dissipated through the heat sink.

4.6 Technical data

4.6.3 400 V Power Modules

Table 4- 21 Technical data of the PM240-2, FSA (400 V) (1/2)

Line voltage 3-phase 380 ... 480 V AC \pm 10%					
		Internal			
Article No. without integrated line filter with integrated line filter		6SL3210- 1PE11-8UL1 1PE11-8AL1	6SL3210- 1PE12-3UL1 1PE12-3AL1	6SL3210- 1PE13-2UL1 1PE13-2AL1	6SL3210- 1PE14-3UL1 1PE14-3AL1
Output current					
Rated current I_n	A	1.7	2.2	3.1	4.1
Base-load current I_H	A	1.3	1.7	2.2	3.1
for S6 operation (40%) I_{S6}	A	2.0	2.5	3.5	4.5
Peak current I_{max}	A	2.6	3.4	4.7	6.2
Unit rating ¹⁾					
on basis of I_n	kW	0.55	0.75	1.1	1.5
on basis of I_H	kW	0.37	0.55	0.75	1.1
Rated pulse frequency	kHz	4	4	4	4
Max. Pulse frequency	kHz	16	16	16	16
Power loss	kW	0.04	0.04	0.04	0.07
Cooling air requirement	l/s	5	5	5	5
Sound pressure level LpA (1 m)	dB	49.2	49.2	49.2	49.2
24 V DC supply for the Control Unit	A	1.0	1.0	1.0	1.0
Rated input current ²⁾	A	2.3	2.9	4.1	5.5
Resistance value of the external braking resistor	Ω	≥ 370	≥ 370	≥ 370	≥ 370
Max. Cable length to the braking resistor	m	15	15	15	15
Line supply connection L1, L2, L3, PE		Screw-type terminals Cross head M2.5 Conductor cross section: 1.5 ... 2.5 mm ² Tightening torque: 0.5 Nm			
Motor connection U2, V2, W2 \oplus					
DC-link connection, connection for braking resistor DCP/R1, DCN, R2					
Max. Motor cable length ³⁾ shielded / unshielded	m	50 / 100			
Degree of protection		IP20			
Weight					
Without line filter	kg	1.4	1.4	1.4	1.4
With line filter	kg	1.5	1.5	1.5	1.5

1) Rated output of a typical standard induction motor at 400 V.

2) The input current depends on the motor load and line impedance. The input currents apply for a load with the type rating (based on I_{rated}) for a line impedance corresponding to $u_k = 1\%$.

3) To observe the limit values of EN 61800-3 category C2, for Power Modules PM240-2 with integrated line filter 50 m (shielded) is the max. motor cable length. A cable length up to 150 m is possible for C2 if you use an unfiltered Power Module with an external line filter class B and a motor reactor.

Table 4- 22 Technical data of the PM240-2, FSA (400 V) (2/2)

Line voltage 3-phase 380 ... 480 V AC \pm 10%				
		Internal		Push-through
Article No. without integrated line filter with integrated line filter		6SL3210– 1PE16-1UL1 1PE16-1AL1	6SL3210– 1PE18-0UL1 1PE18-0AL1	6SL3211– 1PE18-0UL1 1PE18-0AL1
Output current				
Rated current I_n	A	5.9	7.7	7.7
Base-load current I_H	A	4.1	5.9	5.9
for S6 operation (40%) I_{S6}	A	6.5	8.5	8.5
Peak current I_{max}	A	8.9	11.8	11.8
Unit rating ¹⁾				
on basis of I_n	kW	2.2	3.0	3.0
on basis of I_H	kW	1.5	2.2	2.2
Rated pulse frequency	kHz	4	4	4
Max. Pulse frequency	kHz	16	16	16
Power loss	kW	0.1	0.12	0.12 ⁴⁾
Cooling air requirement	l/s	5	5	7
Sound pressure level LpA (1 m)	dB	56.3	56.3	56.3
24 V DC supply for the Control Unit	A	1.0	1.0	1.0
Rated input current ²⁾	A	7.7	10.1	10.1
Resistance value of the external braking resistor	Ω	≥ 140	≥ 140	≥ 140
Max. Cable length to the braking resistor	m	15	15	15
Line supply connection L1, L2, L3, PE		Screw-type terminals Cross head M2.5		
Motor connection U2, V2, W2 		Conductor cross section: 1.5 ... 2.5 mm ² Tightening torque: 0.5 Nm		
DC-link connection, connection for braking resistor DCP/R1, DCN, R2				
Max. Motor cable length ³⁾ shielded / unshielded	m	50 / 100		
Degree of protection		IP20		in the cabinet: IP20 outside: IP54
Weight				
Without line filter	kg	1.4	1.4	1.7
With line filter	kg	1.5	1.5	1.8

1) Rated output of a typical standard induction motor at 400 V.

2) The input current depends on the motor load and line impedance. The input currents apply for a load with the type rating (based on I_{rated}) for a line impedance corresponding to $u_k = 1\%$.

3) To observe the limit values of EN 61800-3 category C2, for Power Modules PM240-2 with integrated line filter 50 m (shielded) is the max. motor cable length. A cable length up to 150 m is possible for C2 if you use an unfiltered Power Module with an external line filter class B and a motor reactor.

4) Power loss in the cabinet: 0.02 kW. The remaining power loss is dissipated through the heat sink.

4.6 Technical data

Table 4- 23 Technical data of the PM240-2, FSB (400 V)

Line voltage 3-phase 380 ... 480 V AC \pm 10%					
		Internal			Push-through
Article No. without integrated line filter with integrated line filter		6SL3210- 1PE21-1UL0 1PE21-1AL0	6SL3210- 1PE21-4UL0 1PE21-4AL0	6SL3210- 1PE21-8UL0 1PE21-8AL0	6SL3211- 1PE21-8UL0 1PE21-8AL0
Output current					
Rated current I_n	A	10.2	13.2	18.0	18.0
Base-load current I_H	A	7.7	10.2	13.2	13.2
for S6 operation (40%) I_{S6}	A	11.2	14.5	19.8	19.8
Peak current I_{max}	A	15.4	20.4	27.0	27.0
Unit rating ¹⁾					
on basis of I_n	kW	4.0	5.5	7.5	7.5
on basis of I_H	kW	3.0	4.0	5.5	5.5
Rated pulse frequency	kHz	4	4	4	4
Max. Pulse frequency	kHz	16	16	16	16
Power loss	kW	0.11	0.15	0.2	0.2 ⁴⁾
Cooling air requirement	l/s	9.2	9.2	9.2	9.2
Sound pressure level L_{pA} (1 m)	dB	61.5	61.5	61.5	61.5
24 V DC supply for the Control Unit	A	1.0	1.0	1.0	1.0
Rated input current ²⁾	A	13.3	17.2	22.2	22.2
Resistance value of the external braking resistor	Ω	≥ 75	≥ 75	≥ 75	≥ 75
Max. Cable length to the braking resistor	m	15	15	15	15
Line supply connection L1, L2, L3, PE		Screw-type terminals Cross head M2.5			
Motor connection U2, V2, W2 		Conductor cross section: 1.5 ... 6 mm ² Tightening torque: 0.6 Nm			
DC-link connection, connection for braking resistor DCP/R1, DCN, R2					
Max. Motor cable length ³⁾ shielded / unshielded	m	50 / 100			
Degree of protection		IP20			in the cabinet: IP20 outside: IP54
Weight					
Without line filter	kg	2.9	2.9	3.0	3.6
With line filter	kg	3.1	3.1	3.2	3.9

1) Rated output of a typical standard induction motor at 400 V.

2) The input current depends on the motor load and line impedance. The input currents apply for a load with the type rating (based on I_{rated}) for a line impedance corresponding to $u_k = 1\%$.

3) To observe the limit values of EN 61800-3 category C2, for Power Modules PM240-2 with integrated line filter 50 m (shielded) is the max. motor cable length. A cable length up to 150 m is possible for C2 if you use an unfiltered Power Module with an external line filter class B and a motor reactor.

4) Power loss in the cabinet: 0,045 kW. The remaining power loss is dissipated through the heat sink.

Table 4- 24 Technical data of the PM240-2, FSC (400 V)

Line voltage 3-phase 380 ... 480 V AC \pm 10%				
		Internal		Push-through
Article No. without integrated line filter with internal line filter		6SL3210– 1PE22-7UL0 1PE22-7AL0	6SL3210– 1PE23-3UL0 1PE23-3AL0	6SL3211– 1PE23-3UL0 1PE23-3AL0
Output current				
Rated current I_n	A	26.0	32.0	32.0
Base-load current I_H	A	18.0	26.0	26.0
for S6 operation (40%) I_{S6}	A	28.6	37.1	37.1
Peak current I_{max}	A	39.0	52.0	52.0
Unit rating ¹⁾				
on basis of I_n	kW	11.0	15.0	15.0
on basis of I_H	kW	7.5	11.0	11.0
Rated pulse frequency	kHz	4	4	4
Max. Pulse frequency	kHz	16	16	16
Power loss	kW	0.3	0.37	0.37 ⁴⁾
Cooling air requirement	l/s	18.5	18.5	18.5
Sound pressure level LpA (1 m)	dB	64.9	64.9	64.9
24 V DC supply for the Control Unit	A	1.0	1.0	1.0
Rated input current ²⁾	A	32.6	39.9	39.9
Resistance value of the external braking resistor	Ω	≥ 30	≥ 30	≥ 30
Max. Cable length to the braking resistor	m	15	15	15
Line supply connection L1, L2, L3, PE		Screw-type terminals Cross head M4		
Motor connection U2, V2, W2 		Conductor cross section: 6 ... 16 mm ² Tightening torque: 1.3 Nm		
DC-link connection, connection for braking resistor DCP/R1, DCN, R2				
Max. Motor cable length ³⁾ shielded / unshielded	m	50 / 100		
Degree of protection		IP20		in the cabinet: IP20 outside: IP54
Weight				
Without line filter	kg	4.7	4.8	5.8
With line filter	kg	5.3	5.4	6.3

1) Rated output of a typical standard induction motor at 400 V.

2) The input current depends on the motor load and line impedance. The input currents apply for a load with the type rating (based on I_{rated}) for a line impedance corresponding to $u_k = 1\%$.

3) To observe the limit values of EN 61800-3 category C2, for Power Modules PM240-2 with integrated line filter 50 m (shielded) is the max. motor cable length. A cable length up to 150 m is possible for C2 if you use an unfiltered Power Module with an external line filter class B and a motor reactor.

4) Power loss in the cabinet: 0.075 kW. The remaining power loss is dissipated through the heat sink.

4.6 Technical data

Table 4- 25 Technical data of the PM240-2, FSD (400 V)

Line voltage 3-phase 380 ... 480 V AC -20/+10 %					
		Internal			
Article No. without integrated line filter with internal line filter		6SL3210- 1PE23-8UL0 1PE23-8AL0	6SL3210- 1PE24-5UL0 1PE24-5AL0	6SL3210- 1PE26-0UL0 1PE26-0AL0	6SL3210- 1PE27-5UL0 1PE27-5AL0
Output current					
Rated current I_n	A	38	45	60	75
Base-load current I_H	A	32	38	45	60
for S6 operation (40%) I_{S6}	A	45	54	72	90
Peak current I_{max}	A	64	76	90	120
Unit rating ¹⁾					
on basis of I_n	kW	18.5	22	30	37
on basis of I_H	kW	15	18.5	22	30
Rated pulse frequency	kHz	4	4	4	4
Max. Pulse frequency		16	16	16	16
Power loss	kW	0.55	0.68	0.76	1.01
Cooling air requirement	l/s	55	55	55	55
24 V DC supply for the Control Unit	A	1.0	1.0	1.0	1.0
Rated input current ²⁾	A	44	52	70	77
Resistance value of the external braking resistor	Ω	≥ 27	≥ 27	≥ 15	≥ 15
Max. Cable length to the braking resistor	m	15	15	15	15
Line supply connection L1, L2, L3, PE		Screw-type terminal			
Motor connection U2, V2, W2, PE		Torx M5			
DC link connection DCP, DCN		Conductor cross section: 16 ... 35 mm ² Tightening torque: 2.5 ... 4.5 Nm			
Connection for braking resistor R1, R2		Screw-type terminal Torx M4 Conductor cross section. 2.5 ... 16 mm ² Tightening torque: 1.2 ... 1.5 m			
Max. Motor cable length ³⁾ shielded / unshielded	m	200 / 300			
Degree of protection		IP20			
Weight					
Without line filter	kg	16	16	17	17
With line filter	kg	17.5	17.5	18.5	18.5

- 1) Rated output of a typical standard induction motor at 400 V.
- 2) The input current depends on the motor load and line impedance. The input currents apply for a load with the type rating (based on I_{rated}) for a line impedance corresponding to $u_k = 1\%$.
- 3) To observe the limit values of EN 61800-3 category C2, for Power Modules PM240-2 with integrated line filter 150 m (shielded) it the max. motor cable length.

Table 4- 26 Technical data of the PM240-2, FSE (400 V)

Line voltage 3-phase 380 ... 480 V AC -20/+10 %			
		Internal	
Article No. without integrated line filter with internal line filter		6SL3210- 1PE28-8UL0 1PE28-8AL0	6SL3210- 1PE31-1UL0 1PE31-1AL0
Output current			
Rated current I_n	A	90	110
Base-load current I_H	A	75	90
for S6 operation (40%) I_{S6}	A	108	132
Peak current I_{max}	A	150	180
Unit rating ¹⁾			
on basis of I_n	kW	45	55
on basis of I_H	kW	37	45
Rated pulse frequency	kHz	4	4
Max. Pulse frequency	kHz	8	8
Power loss	kW	1.19	1.54
Cooling air requirement	l/s	83	83
24 V DC supply for the Control Unit	A	1.0	1.0
Rated input current ²⁾	A	93	113
Resistance value of the external braking resistor	Ω	≥ 8.2	≥ 8.2
Max. Cable length to the braking resistor	m	15	15
Line supply connection L1, L2, L3, PE		Screw-type terminal	
Motor connection U2, V2, W2, PE		Torx M8	
DC link connection DCP, DCN		Conductor cross section. 25 ... 70 mm ² Tightening torque: 8.0 ... 10 Nm	
Connection for braking resistor R1, R2		Screw-type terminal Torx M5 Conductor cross section. 16 ... 35 mm ² Tightening torque: 2.5 ... 4.5 Nm	
Max. Motor cable length ³⁾ shielded / unshielded	m	200 / 300	
Degree of protection		IP20	
Weight			
Without line filter	kg	26	26
With line filter	kg	28	28

1) Rated output of a typical standard induction motor at 400 V.

2) The input current depends on the motor load and line impedance. The input currents apply for a load with the type rating (based on I_{rated}) for a line impedance corresponding to $u_k = 1\%$.

3) To observe the limit values of EN 61800-3 category C2, for Power Modules PM240-2 with integrated line filter 150 m (shielded) it the max. motor cable length.

4.6.4 Characteristics

Note

Derating characteristics

You will find the derating characteristics in Chapter Derating (Page 31).

Overload capability

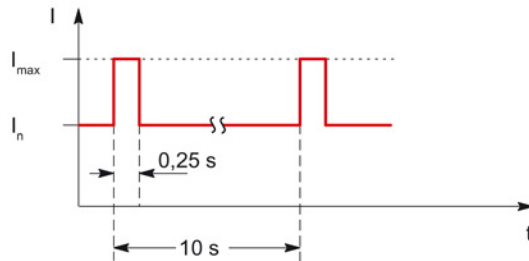

Figure 4-20 Duty cycle with initial load (for servo drives)

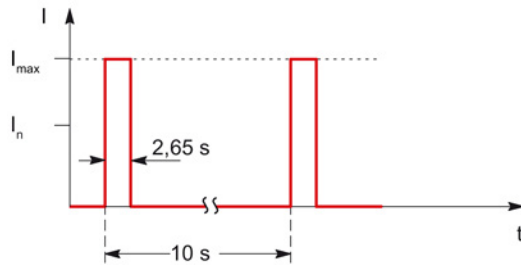

Figure 4-21 Duty cycle without initial load (for servo drives)

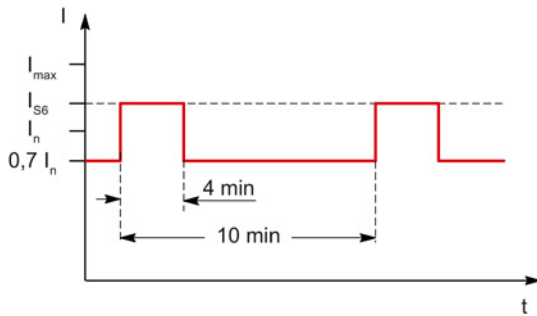

Figure 4-22 S6 duty cycle with initial load (for servo drives)

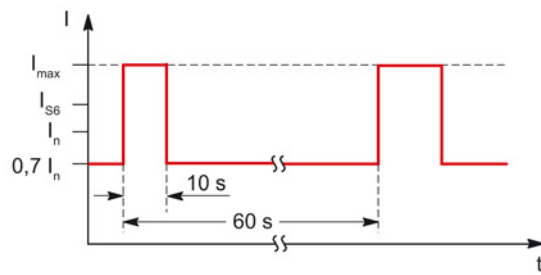

Figure 4-23 S6 peak current duty cycle with initial load (for servo drives)

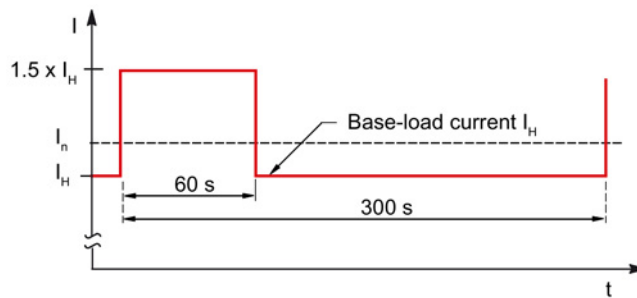

Figure 4-24 Duty cycle with 60 s overload with a duty cycle duration of 300 s

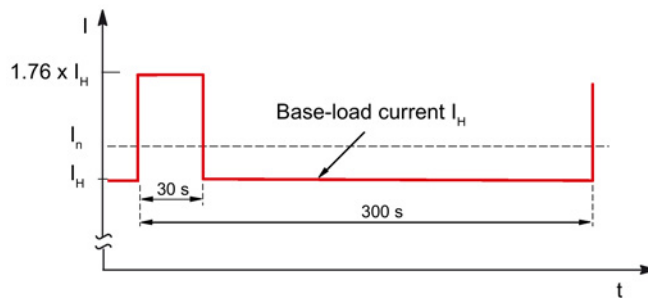

Figure 4-25 Duty cycle with 30 s overload with a duty cycle duration of 300 s

Note

The short leading edges of the duty cycles shown can only be achieved using speed or torque control.

DC link components

5.1 DC link fuses

The Power Modules PM240-2 FSD and FSE do not have integrated overcurrent protection for the DC link. You must therefore use aR characteristics fuses.

Line voltage 3-phase 380 ... 480 V AC

Table 5- 1 Fuses for Power Modules PM240-2 FSD

Article No. without integrated line filter with internal line filter		6SL3210- 1PE23-8UL0 1PE23-8AL0	6SL3210- 1PE24-5UL0 1PE24-5AL0	6SL3210- 1PE26-0UL0 1PE26-0AL0	6SL3210- 1PE27-5UL0 1PE27-5AL0
Fuses NH IEC 60947 Rated current	A	3NE3221 100	3NE3221 100	3NE3222 125	3NE3222 125

Table 5- 2 Fuses for Power Modules PM240-2 FSE

Article No. without integrated line filter with internal line filter		6SL3210- 1PE28-8UL0 1PE28-8AL0	6SL3210- 1PE31-1UL0 1PE31-1AL0
Fuses NH IEC 60947 Rated current	A	3NE3224 160	3NE3225 200

5.2 Braking resistors

5.2.1 Description

The PM240-2 Power Modules cannot feed back regenerated energy into the line supply. For regenerative operation, e.g. the braking of a rotating mass, a braking resistor must be connected to convert the resulting energy into heat.

A thermostatic switch monitors the braking resistor for overtemperature and issues a signal on an isolated contact if the limit value is exceeded.

5.2.2 Safety instructions for blocksize braking resistors

 WARNING
Danger to life if the fundamental safety instructions and residual risks are not heeded
Failure to heed the fundamental safety instructions and residual risks in Chapter 1 can result in accidents causing severe injuries or death.
<ul style="list-style-type: none">• Follow the fundamental safety instructions.• Consider the residual risks on the risk assessment.

 WARNING
Risk of fire and device damage as a result of ground fault / short-circuit
The cables to the braking resistor must be routed so that a ground fault or short circuit can be ruled out. A ground fault can result in fire with associated smoke.
<ul style="list-style-type: none">• Comply with local installation regulations, which allow this fault to be ruled out.• Protect the cables from mechanical damage.• In addition, apply one of the following measures:<ul style="list-style-type: none">– Using cables with double insulation.– Observe adequate clearances, e.g. through the use of spacers.– Route the cables in separate cable ducts or pipes.

 **CAUTION****Risk of burns or damage resulting from high surface temperature of the braking resistor**

The braking resistor can become very hot. You can be severely burnt when touching the surface. Neighboring components can become damaged.

- Mount the braking resistor so that it cannot be touched. If this is not possible, at the dangerous locations, attach an appropriate warning note that is clearly visible and easy to understand.
- To avoid temperature-related damage to adjacent components, follow these rules:
 - For PM240-2 Power Modules installed horizontally close to the ground:
 - Installation on sheet steel > 2 mm
 - Ensure a ventilation clearance of 250 mm at the sides of the braking resistor
 - Ventilation clearance of 1000 mm above the braking resistor
 - For PM240-2 Power Modules when installed vertically against a wall:
 - Installation on sheet steel > 2 mm
 - Ensure a ventilation clearance of 100 mm at the sides of the braking resistor
 - Ventilation clearance of 1000 mm above the braking resistor

5.2.3 Connection examples

The braking resistor is connected directly on the Power Module at the terminals R1 and R2.

The braking resistor must be protected against overheating. This protection function performs the function of a thermostatic switch. The thermostatic switch is included in the scope of supply of the braking resistor. Evaluate the braking resistor temperature monitoring so that the motor is switched off when the resistor is in an overtemperature condition.

Connect the thermostatic switch to a Control Unit

Connect the thermostatic switch to a free digital input of the Control Unit. Set the function of this digital input to the OFF2 command. If the braking resistor overheats, the Power Module is disconnected from the power supply.

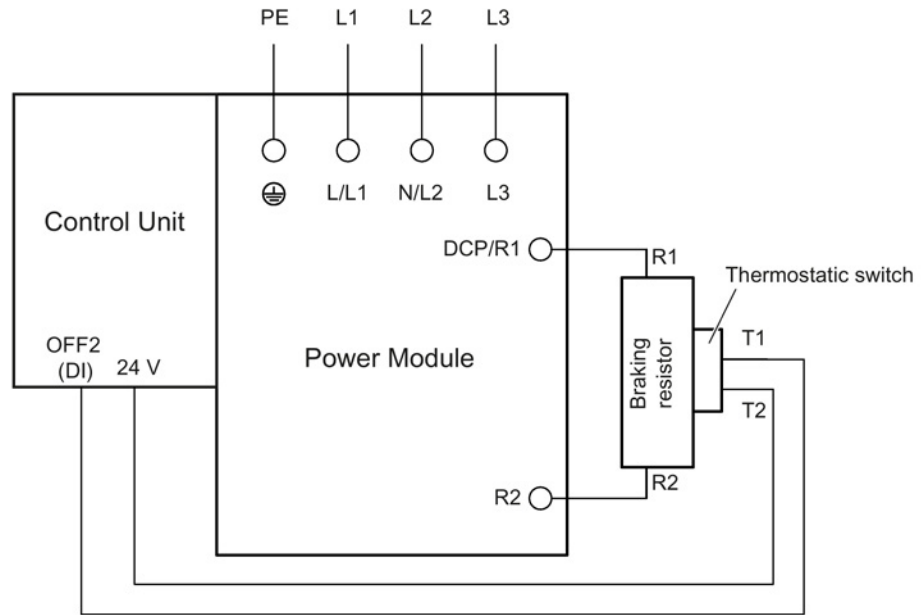

Figure 5-1 Connecting the thermostatic switch on the braking resistor to a Control Unit

5.2.4 Dimension drawings

Braking resistors for PM240-2 Power Modules

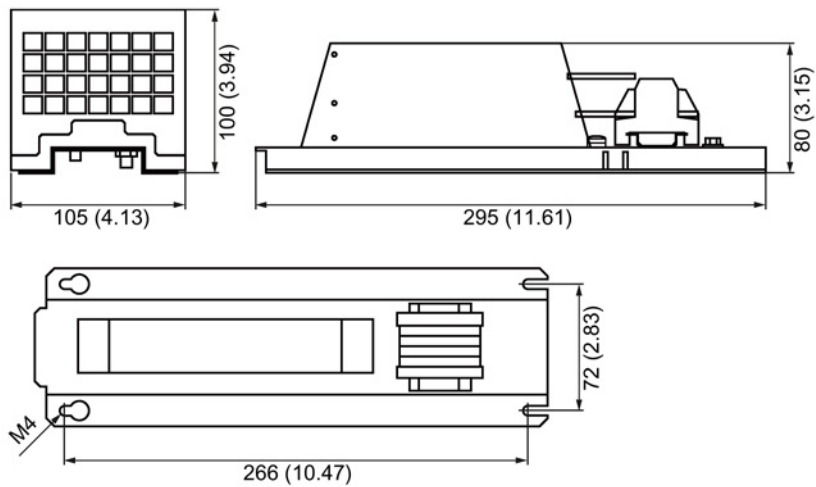

Figure 5-2 Dimension drawing of braking resistor for PM240-2, frame size FSA, 0.55 ... 1.5 kW, all dimensions in mm and (inch)

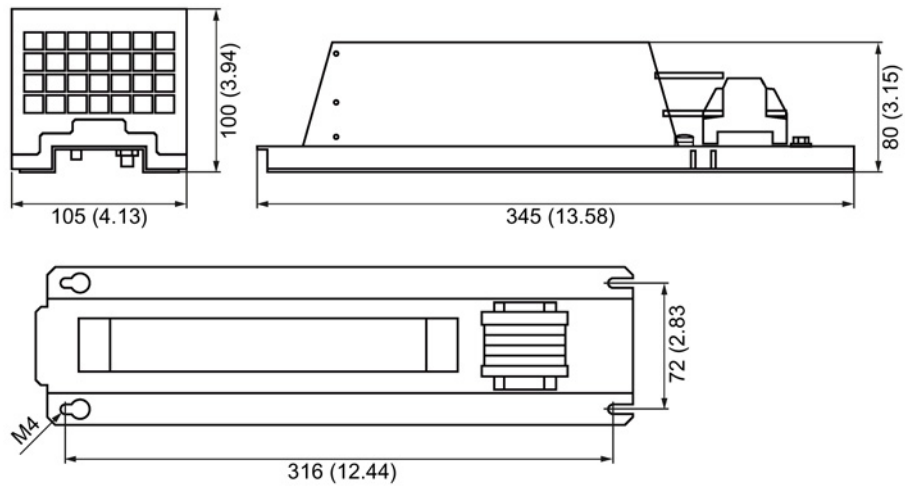

Figure 5-3 Dimension drawing of braking resistor for PM240-2, frame size FSA, 2.2 ... 3.0 kW, all dimensions in mm and (inch)

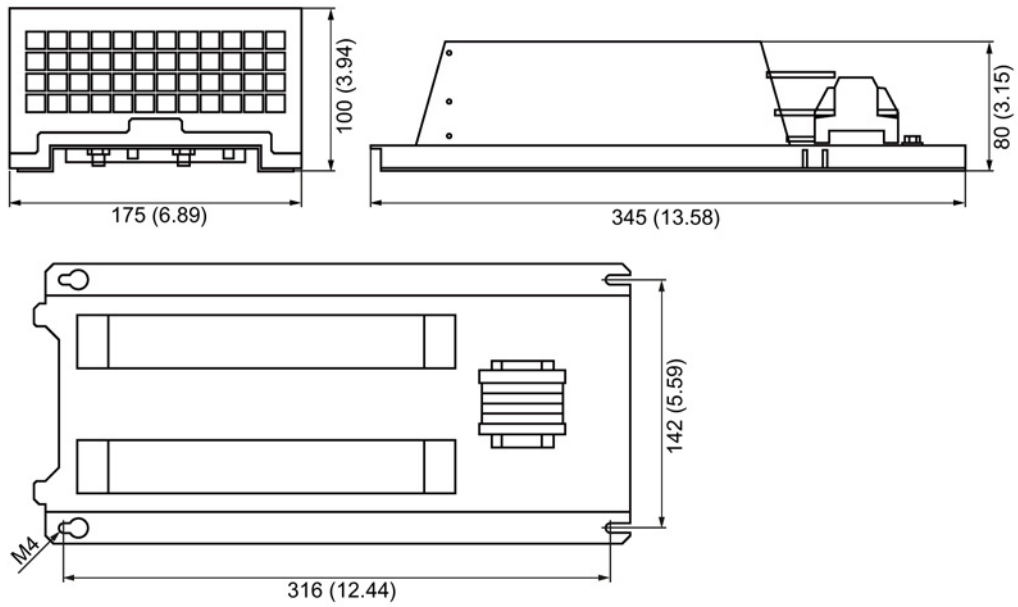

Figure 5-4 Dimension drawing braking resistor for PM240-2, frame size FSB, all data in mm (inches)

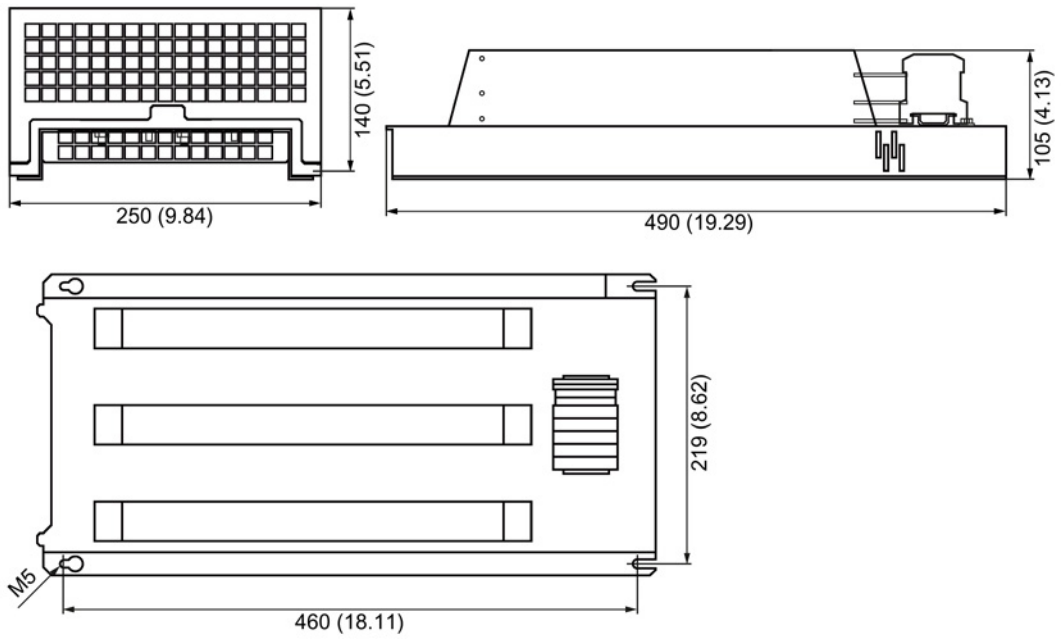

Figure 5-5 Dimension drawing of PM240-2, frame size FSC, all data in mm (inches)

5.2.5 Installation

The braking resistor for all modules is connected at terminals R1 and R2. Since it generates heat, it should be mounted to the side of the Power Modules.

The braking resistors for the Power Modules of the FSD to FSE frame sizes should be located outside the cabinet or the switchgear room to take the resulting heat loss away from the Power Modules, This reduces the level of air conditioning required.

The braking resistors can be installed horizontally or vertically. The power connections on vertically installed resistors must be below.

Table 5- 3 Connecting the braking resistors for PM240-2 Power Modules on the mounting surface

Frame size	Fastening	Tightening torque
FSA	4 x M4 screws	Tightening torque: 2.5 Nm
FSB	4 x M4 nuts 4 x M4 washers	
FSC	4 x M5 screws 4 x M5 nuts 4 x M5 washers	Tightening torque: 2.5 Nm

Note

PE connection

The PE connection for the braking resistor is established via the shield connection for frame sizes FSA to FSC.

For installation according to EN 60204-1 and EN 61800-5-1, the PE connection on the housing must be used. The PE conductor in the pigtail is, in this case, not to be used, but can be suitably tied off or cut off.

For frame sizes FSD and FSE, PE connection of the braking resistor is achieved via the shield connection plate above terminals R1 and R2.

5.2.6 Technical data

Line voltage 1/3-phase 200 V AC -10 % to 240 V AC +10 %:

Note

Use the following or comparable braking resistors for the PM240-2 Power Modules 200 V. The technical properties and statements made by the manufacturer apply.

Table 5- 4 Braking resistors for Blocksize PM240-2, 200 V, FSA - FSC

Manufacturer		Company Heine Resistors GmbH		
Manufacturer's designation		GWHS 167-60x30-K IP20 200. ±7% 37.5 W TS KA 100 cm	GWHS 217-60x30-K IP20 68. ±7% 110 W TS KA 100 cm	GWHS 337-60x30-K IP20 37. ±7% 200 W TS KA 100 cm
Manufacturer's Article No.		JJY 02 31467 2 0008	JJY 02 31517 2 0007	JJY 02 31637 2 0018
Resistance	Ω	200	68	37
Unit rating P _{DB}	kW	0.0375	0.11	0.2
Peak power P _{max}	kW	0.75	2.2	4.0
Load duration for peak power T _a	s	12	12	12
Period duration of braking duty cycle T	s	240	240	240
Degree of protection		IP20	IP20	IP20
Power connections (including PE) Max. connectable cross-section: Tightening torque:		2.5 mm ² 0.5 Nm	4.0 mm ² 0.5 Nm	6.0 mm ² 0.8 Nm
Thermostatic switch Max. connectable cross-section: Tightening torque:		2.5 mm ² 0.5 Nm	2.5 mm ² 0.5 Nm	2.5 mm ² 0.5 Nm
Thermostatic switch (NC contact) Maximum contact load connecting cable		250 V AC / 2.5 A	250 V AC / 2.5 A	250 V AC / 2.5 A
Weight	kg	0.5	0.7	1.1
Matching Power Modules ¹⁾		6SL3210- 1PB13-0xL0 1PB13-8xL0 6SL3211- 1PB13-8xL0	6SL3210- 1PB15-5xL0 1PB17-4xL0 1PB21-0xL0 6SL3211- 1PB21-0xL0	6SL3210- 1PB21-4xL0 1PB21-8xL0 6SL3211- 1PB21-8xL0
Frame size		FSA	FSB	FSC
Unit rating of the Power Module	kW	0.55 ... 0.75	1.1 ... 2.2	3.0 ... 4.0

¹⁾ x = A: Power Module with integrated line filter, x = U: Power Module without integrated line filter

Line voltage 3-phase 380 VAC -10% to 480 VAC +10%

Table 5- 5 Braking resistors for Blocksize PM240-2, 400 V, FSA - FSC

Article No. 6SL3201-		0BE14-3AA0	0BE21-0AA0	0BE21-8AA0	0BE23-8AA0
Resistance	Ω	370	140	75	30
Unit rating P _{DB}	kW	0.075	0.2	0.375	0.925
Peak power P _{max}	kW	1.5	4	7.5	18.5
Load duration for peak power T _a	s	12	12	12	12
Period duration of braking duty cycle T	s	240	240	240	240
Degree of protection		IP20	IP20	IP20	IP20
Power connections (including PE) Max. connectable cross-section: Tightening torque:		2.5 mm ² 0.5 Nm	2.5 mm ² 0.5 Nm	4.0 mm ² 0.7 Nm	6.0 mm ² 3.0 Nm
Thermostatic switch Max. connectable cross-section: Tightening torque:		2.5 mm ² 0.5 Nm	2.5 mm ² 0.5 Nm	2.5 mm ² 0.5 Nm	2.5 mm ² 0.5 Nm
Thermostatic switch (NC contact) Maximum contact load connecting cable		250 V AC / 2.5 A	250 V AC / 2.5 A	250 V AC / 2.5 A	250 V AC / 2.5 A
Weight	kg	1.5	1.8	2.7	6.2
Matching Power Modules ¹⁾		6SL3210- 1PE11-8xL1 1PE12-3xL1 1PE13-2xL1 1PE14-3xL1	6SL3210- 1PE16-1xL1 1PE18-0xL0 6SL3211- 1PE18-0xL1	6SL3210- 1PE21-1xL0 1PE21-4xL0 1PE21-8xL0 6SL3211- 1PE21-8xL0	6SL3210- 1PE22-7xL0 1PE23-3xL0 6SL3211- 1PE23-3xL0
Frame size		FSA	FSA	FSB	FSC
Unit rating of the Power Module	kW	0.55 ... 1.5	2.2 ... 3.0	5.5 ... 7.5	11 ... 15

¹⁾ x = A: Power Module with integrated line filter, x = U: Power Module without integrated line filter

Table 5- 6 Braking resistors for Blocksize PM240-2, 400 V, FSD - FSE

Article No. 6SE6400-		4BD21-2DA0	4BD22-2EA1	4BD24-0FA0
Resistance	Ω	27	15	8.2
Unit rating P _{DB}	kW	1.2	2.2	4
Peak power P _{max}	kW	24	44	80
Load duration for peak power T _a	s	12	12	12
Period duration of braking duty cycle T	s	240	240	240
Degree of protection		IP20	IP20	IP20

Article No. 6SE6400-		4BD21-2DA0	4BD22-2EA1	4BD24-0FA0
Power connections (including PE) Tightening torque:		Stud M6 10 Nm	Stud M6 10 Nm	Stud M6 10 Nm
Thermostatic switch Max. connectable cross-section: Tightening torque:		2.5 mm ² 0.5 Nm	2.5 mm ² 0.5 Nm	2.5 mm ² 0.5 Nm
Thermostatic switch (NC contact) Maximum contact load connecting cable		250 V AC / 2.5 A	250 V AC / 2.5 A	250 V AC / 2.5 A
Dimensions (W x H x D)	mm	270 x 515 x 175	326 x 301 x 484	395 x 650 x 315
Weight	kg	7.4	10.6	16.7
Matching Power Modules ¹⁾		6SL3210- 1PE23-8xL0 1PE24-5xL0	6SL3210- 1PE26-0xL0 1PE27-5xL0	6SL3210- 1PE28-8xL0 1PE31-1xL0
Frame size		FSD	FSD	FSE
Unit rating of the Power Module	kW	18.5 ... 22	30 ... 37	45 ... 55

¹⁾ x = A: Power Module with integrated line filter, x = U: Power Module without integrated line filter

Note

Braking resistors FSD ... FSE

Only use braking resistors that are UL approved, and have successfully passed the "Abnormal Operation Test" according to UL 508.

Duty cycles

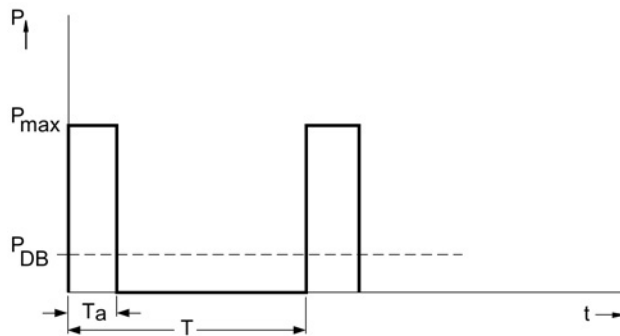

Figure 5-6 Load diagram for the braking resistor, in Blocksize format

T [s]: Period duration of braking duty cycle

T_a [s]: Duration of load with peak power

P_{DB} [kW]: Unit rating of the braking resistor

P_{max} [kW]: Peak power of the braking resistor

Power components on the motor side

6.1 Motor reactors

6.1.1 Description

Motor reactors reduce the voltage stress on the motor windings by reducing the voltage gradients at the motor terminals that occur when motors are fed from drive converters. At the same time, the capacitive re-charging currents that additionally load the output of the Power Module when longer motor cables are used are simultaneously reduced.

The motor reactors for Power Modules PM240-2, FSA - FSE, are suitable for a pulse frequency of 4 kHz. Higher pulse frequencies are not permissible.

6.1.2 Safety instructions for motor reactors

 **WARNING**

Danger to life if the fundamental safety instructions and residual risks are not heeded

Failure to heed the fundamental safety instructions and residual risks in Chapter 1 can result in accidents causing severe injuries or death.

- Follow the fundamental safety instructions.
- Consider the residual risks on the risk assessment.

 **WARNING**

Danger of fire through overheating for insufficient ventilation clearances

Insufficient ventilation clearances can result in overheating with danger to persons as a result of smoke and fire. Further, increased failures can occur and the service life of units/systems may be shortened.

- It is essential that you maintain 100 mm ventilation clearances above and below the component.

 CAUTION
Risk of burns resulting from high surface temperature of the motor reactor The motor reactors can become very hot. You can be severely burnt when touching the surface. <ul style="list-style-type: none">• Mount the motor reactors so that they cannot be touched. If this is not possible, at the dangerous locations, attach an appropriate warning note that is clearly visible and easy to understand.

NOTICE
Damage to the motor reactors due to use of non-approved components If components are used that have not been approved, damage or malfunctions can occur in the devices or the system itself. There is a risk that the motor reactor will be thermally damaged. <ul style="list-style-type: none">• Use only motor reactors that have been approved for SINAMICS by Siemens.

NOTICE
Damage to the motor reactor if the maximum output frequency is exceeded The maximum permissible output frequency when motor reactors are used is 150 Hz. At a higher output frequency, the motor reactor may be damaged. <ul style="list-style-type: none">• Do not operate the motor reactors above the maximum permissible output frequency of 150 Hz.

NOTICE
Damage to the motor reactor if the maximum pulse frequency is exceeded The maximum permissible pulse frequency when using motor reactors is 4 kHz. At a higher pulse frequency, the motor reactor may be damaged. <ul style="list-style-type: none">• Do not operate the motor reactors on the Power Module above the maximum permissible pulse frequency of 4 kHz.

6.1.3 Dimension drawings

Motor reactors 6SL3202-0AE16-1AC0 and 6SL3202-0AE18-8CA0 for PM240-2, FSA or FSB

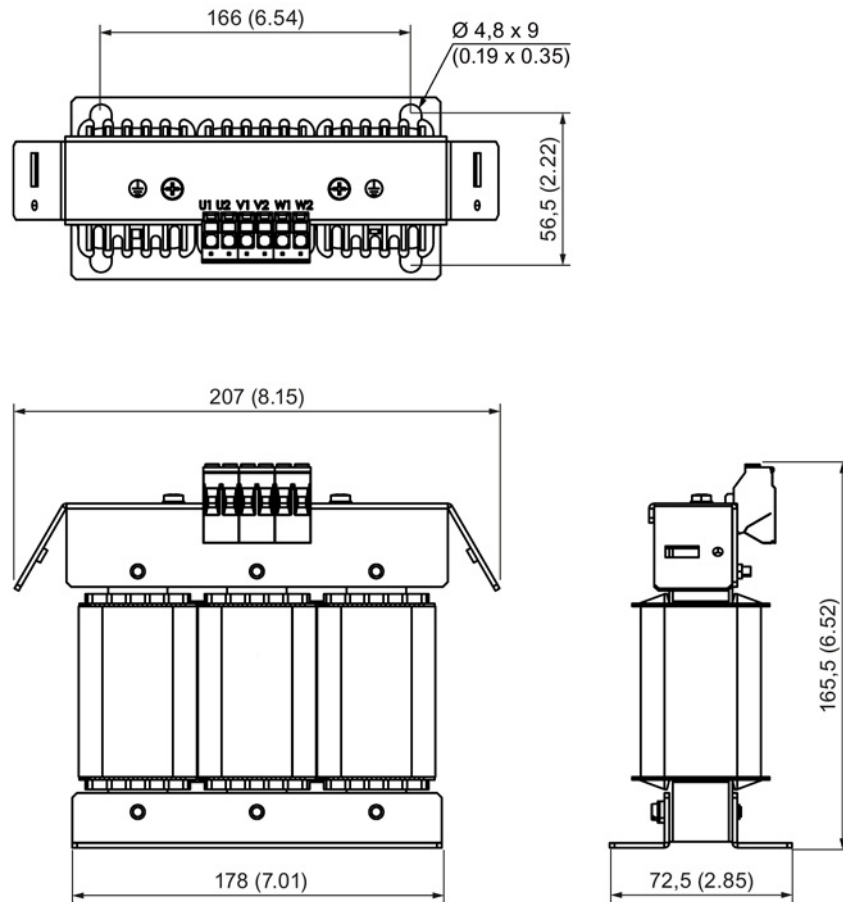

Figure 6-1 Dimension drawing motor reactors for PM240-2, FSA or FSB, all data in mm and (inch)

6.1 Motor reactors

Motor reactors 6SL3202-0AE21-8AC0 for PM240-2, FSB or FSC

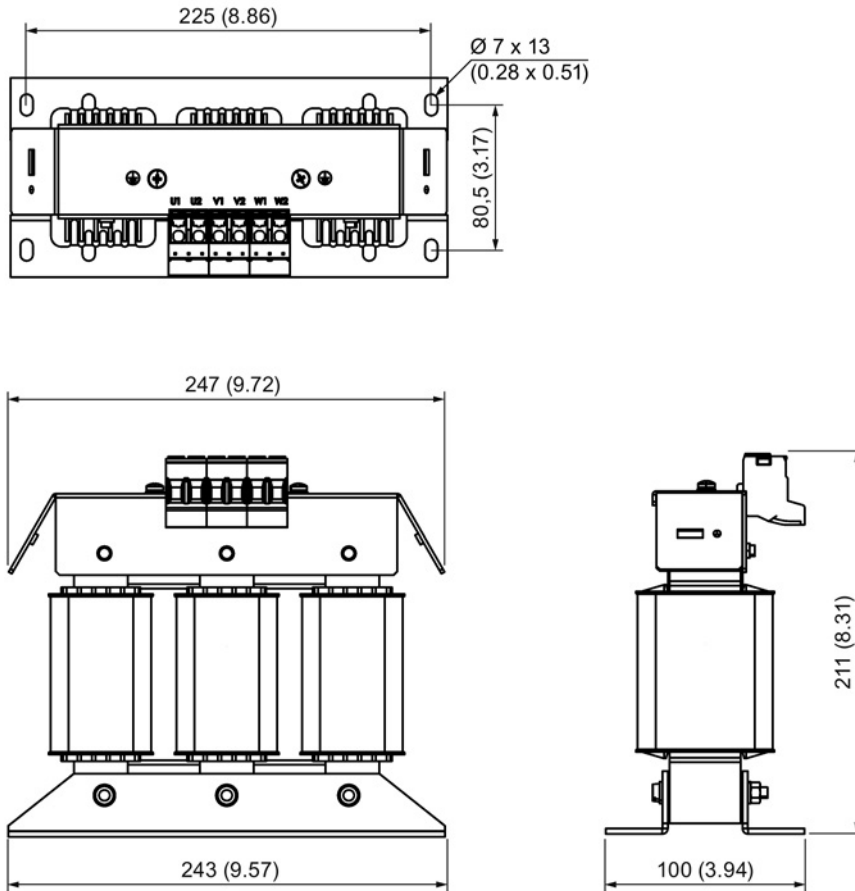

Figure 6-2 Dimension drawing motor reactors for PM240-2, FSB or FSC, all data in mm and (inch)

Motor reactors 6SL3202-0AE23-8AC0 for PM240-2, FSC or FSD

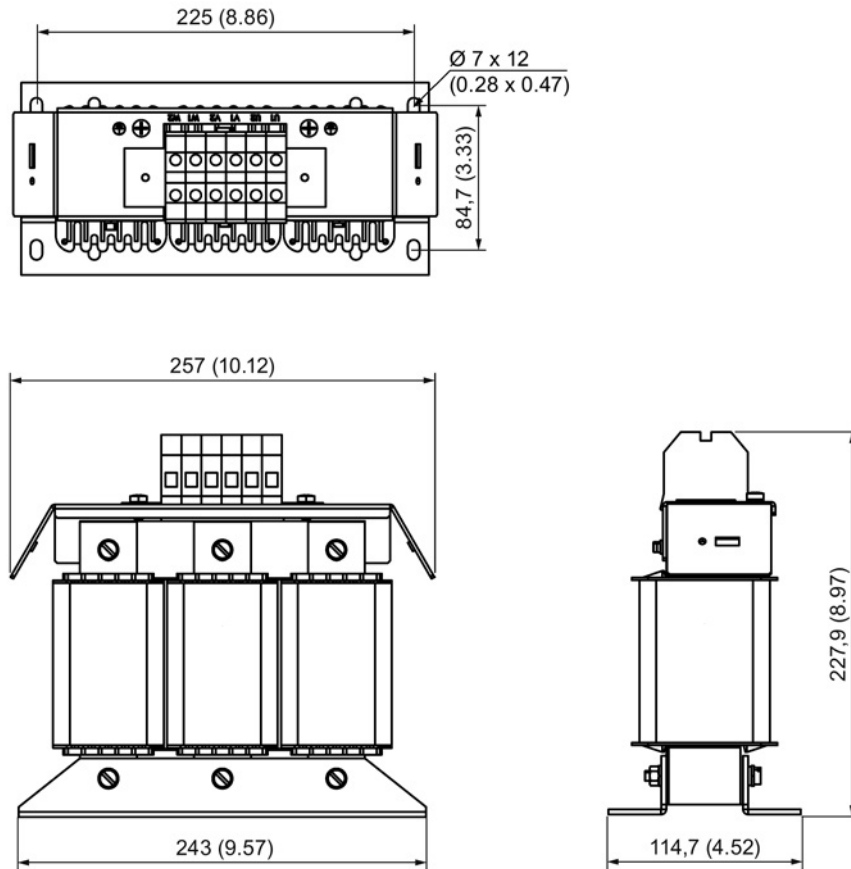
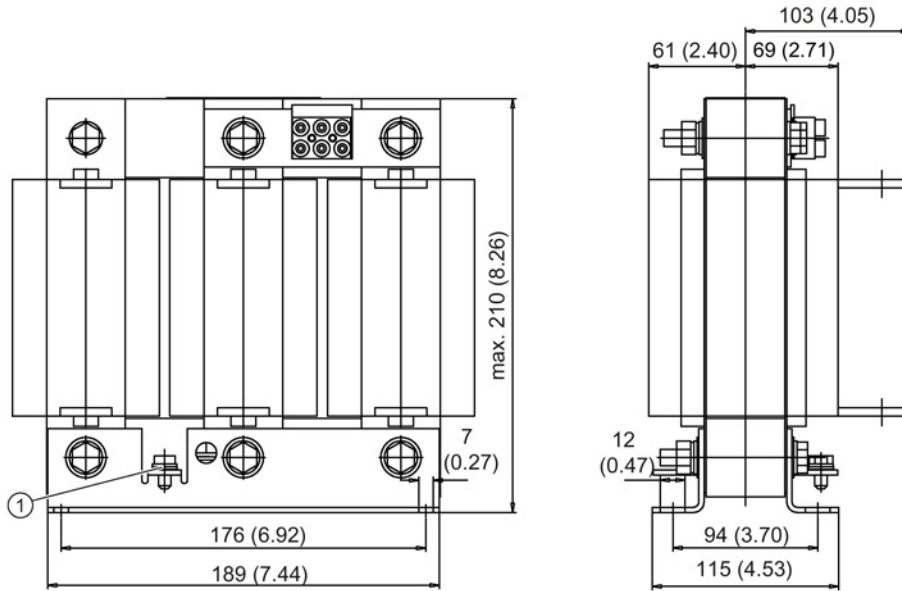

Figure 6-3 Dimension drawing motor reactors for PM240-2, FSC or FSD, all data in mm and (inch)

6.1 Motor reactors

Motor reactors 6SE6400-3CT03-8DD0 for PM240-2, FSD



① PE terminal M6 x 12

Figure 6-4 Dimension drawing motor reactors for PM240-2, FSD, all data in mm and (inch)

Motor reactors 6SE6400-3TC07-5ED0 for PM240-2, FSD or FSE

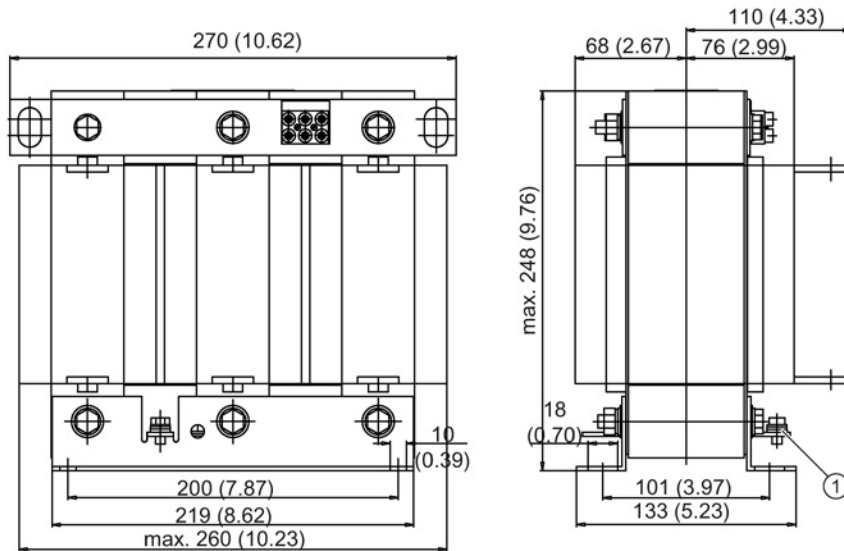

① PE terminal M6 x 12

Figure 6-5 Dimension drawing motor reactors for PM240-2, FSD or FSE, all data in mm and (inch)

Motor reactors 6SE6400-3TC14-5FD0 for PM240-2, FSE

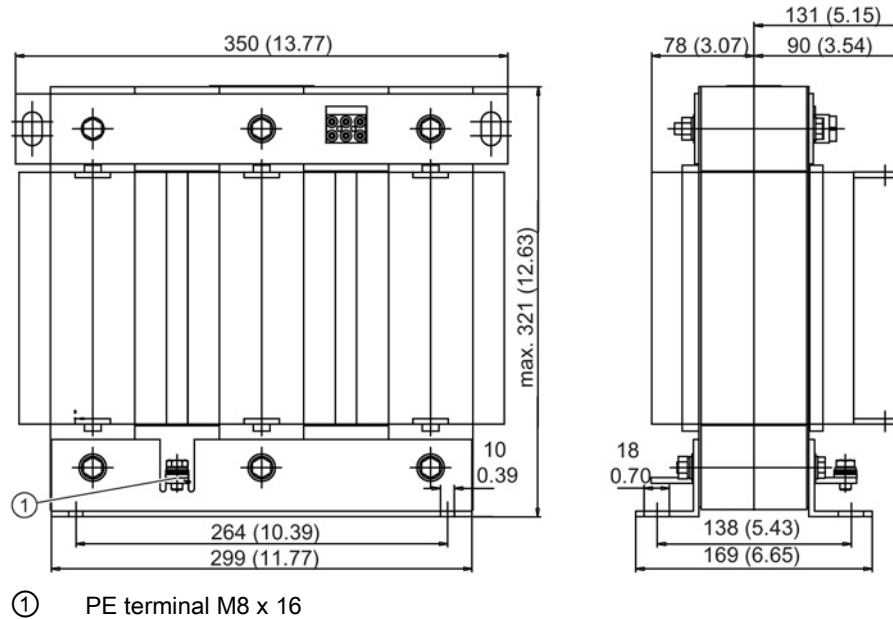

Figure 6-6 Dimension drawing motor reactors for PM240-2, FSE, all data in mm and (inch)

6.1.4 Mounting

The motor reactors for Power Modules PM240-2, frame sizes FSA to FSE, are dimensioned for installation in cabinets. The motor reactor is installed on the mounting surface next to the Power Module.

Table 6- 1 Mounting of motor reactors for PM240-2 Power Modules

Frame size	Fastening	Tightening torque
FSA	4 x M4 screws 4 x M4 nuts 4 x M4 washers	3 Nm
FSB	4 x M5 screws	5 Nm
FSC	4 x M5 nuts 4 x M5 washers	
FSD	4 x M6 screws 4 x M6 nuts 4 x M6 washers	8 Nm
FSE	4 x M8 screws 4 x M8 nuts 4 x M8 washers	10 Nm

6.1.5 Electrical connection

Note

Approved cables for UL applications

Use only 75° C copper cables.

Table 6-2 Securing the connection cables to the motor reactor

Frame size	Terminal connection		PE connection	
	Max. cross-section that can be connected	Tightening torque	Fastening	Tightening torque
FSA	4 mm ²	0.6 ... 0.8 Nm	M4 screw	3 Nm
FSB	10 mm ²	1.5 ... 1.8 Nm	M5 screw	5 Nm
FSC	16 mm ²	2.0 ... 4.0 Nm	M5 screw	5 Nm
FSD	35 mm ²	2.5 ... 4.5 Nm	M6 screw	8 Nm
FSE	70 mm ²	8 ... 10 Nm	M8 screw	10 Nm

6.1.6 Technical data

Table 6- 3 Motor reactors for Power Modules PM240-2, part 1

Article No. 6SL3202-		0AE16-1CA0	0AE18-8CA0	0AE21-8CA0	0AE23-8CA0
Inductance	mH	2.5	1.3	0.54	0.26
Rated current	A	6.1	9.0	18.5	39.0
Power loss	kW	0.09	0.08	0.08	0.11
Degree of protection		IP20	IP20	IP20	IP20
Weight	kg	3.4	3.9	10.1	11.2
Matching Power Modules ¹⁾		Line voltage 1/3-phase 200 V AC -10 % to 240 V AC +10 %:			
		6SL3210- 1PB13-0xL0 1PB13-8xL0 1PB15-5xL0 6SL3211- 1PB13-8xL0	6SL3210- 1PB17-4xL0	6SL3210- 1PB21-0xL0 1PB21-4xL0 1PB21-8xL0 6SL3211- 1PB21-0xL0 1PB21-8xL0	
		Line voltage 3-phase 380 V AC -10% to 480 V AC +10%:			
		6SL3210- 1PE11-8xL1 1PE12-3xL1 1PE13-2xL1 1PE14-3xL1 1PE16-1xL1	6SL3210- 1PE18-0xL1 6SL3211- 1PE18-0xL1	6SL3210- 1PE21-1xL0 1PE21-4xL0 1PE21-8xL0 6SL3211- 1PE21-8xL0	6SL3210- 1PE22-7xL0 1PE23-3xL0 1PE23-8xL0 6SL3211- 1PE23-3xL0
Frame size		FSA/FSB	FSA/FSB	FSB/FSC	FSC/FSD
Unit rating of the Power Module	kW	0.55 ... 2.2	1.5 ... 3	2.2 ... 7.5	11 ... 18.5

¹⁾ x = A: Power Module with integrated line filter, x = U: Power Module without integrated line filter

Table 6- 4 Motor reactors for Power Modules PM240-2, part 2

Article No. 6SE6400-		3TC03-8DD0	3TC07-5ED0	3TC14-5FD0
Inductance	mH	0.82	0.30	0.20
Rated current	A	45	90	178
Power loss	kW	0.20	0.27	0.47
Degree of protection		IP00	IP00	IP00
Weight	kg	19	27	57
Matching Power Modules ¹⁾		Line voltage 3-phase 380 V AC -10% to 480 V AC +10%:		
		6SL3210- 1PE24-5xL0	6SL3210- 1PE26-0xL0 1PE27-5xL0 1PE28-8xL0	6SL3210- 1PE31-1xL0
Frame size		FSD	FSD/FSE	FSE
Unit rating of the Power Module	kW	22	30 ... 45	55

¹⁾ x = A: Power Module with integrated line filter, x = U: Power Module without integrated line filter

CU305 Control Units

7.1 Description

The Control Units

- CU305 PN (PROFINET)
- CU305 DP (PROFIBUS)
- CU305 CAN

are components in which the open-loop and closed-loop control functions for a drive are implemented.

The table below shows an overview of the interfaces of the CU305 Control Units.

Table 7- 1 Number of interface for CU305 PN/CU305 DP/CU305 CAN

Type	CU305 PN	CU305 DP	CU305 CAN
Digital inputs/outputs ¹⁾	4	4	4
Digital inputs, electrically isolated	5	5	5
Failsafe digital inputs (F-DI) ²⁾	3	3	3
Analog input	1	1	1
Failsafe digital output (F-DO) ³⁾	1	1	1
DRIVE-CLiQ interface	1	1	1
PROFINET interface	2	-	-
PROFIBUS interface	-	1	-
CAN interface	-	-	1
Serial interface (RS232)	1	1	1
Power Module Interface (PM-IF)	1	1	1
Encoder interface (HTL/TTL/SSI)	1	1	1
Motor temperature sensor input	1	1	1
24 V electronics power supply	1	1	1
Measuring sockets	2	2	2
Interface for BOP	1	1	1

¹⁾ The bidirectional digital inputs/outputs are designed as "rapid inputs" and can be used for BEROs (3-wire) or measuring probes.

²⁾ If the safety functions of the Control Unit are not being used, the failsafe digital inputs can be used as 6 additional electrically isolated digital inputs.

³⁾ If the safety functions of the Control Unit are not being used, the failsafe digital input can be used as 1 additional electrically isolated digital input.

Note

The rated values of the F-DO meet the requirements of EN 61131-2 for digital DC outputs with 0.5 A rated current.

The operating ranges of the F-DI meet the requirements of EN 61131-2 for type 1 digital inputs.

7.2 Safety instructions for Control Unit CU305

 WARNING
Danger to life if the fundamental safety instructions and residual risks are not heeded Failure to heed the fundamental safety instructions and residual risks in Chapter 1 can result in accidents causing severe injuries or death. <ul style="list-style-type: none">• Follow the fundamental safety instructions.• Consider the residual risks on the risk assessment.

 WARNING
Danger of fire through overheating for insufficient ventilation clearances Insufficient ventilation clearances result in overheating with danger to persons as a result of smoke and fire. Further, increased failures can occur and the service life of units/systems may be shortened. <ul style="list-style-type: none">• It is essential that you ensure 50-mm ventilation clearances above and below the Control Unit and Control Unit Adapter.• Ensure that the air openings are not blocked by connecting cables.

 WARNING
Danger to life due to software manipulation when using exchangeable storage media Storing files on exchangeable storage media poses an increased risk of infection, e.g. with viruses and malware. Incorrect parameter assignment can cause machines to malfunction, which can lead to injuries or death. <ul style="list-style-type: none">• Protect files stored on exchangeable storage media from malicious software using appropriate protection measures, e.g. virus scanners.

NOTICE**Damage to memory card due to electric fields or electrostatic discharge**

Electrical fields or electrostatic discharge may result in the memory card being damaged.

- When removing and inserting the memory card, always observe the ESD regulations.

NOTICE**Risk of component destruction as a result of high leakage currents**

The Control Unit or other PROFIBUS and/or PROFINET nodes can be destroyed if substantial leakage currents flow through the PROFIBUS or PROFINET cable.

- Use a functional equipotential bonding conductor with a cross section of at least 25 mm² between components of a plant or system that are located at a distance from each other.

NOTICE**Device failure due to unshielded or incorrectly routed cables to temperature sensors**

Unshielded or incorrectly routed cables to temperature sensors can result in interference being coupled into the signal processing electronics from the power side. This can significantly disturb all signals (fault messages), even causing individual components to fail (destruction of the devices).

- Only use shielded cables as temperature sensor cables.
- If temperature sensor cables are routed together with the motor cable, use twisted-pair, separately-shielded cables.
- Connect the cable shield at both ends to ground potential over a large surface area.
- Recommendation: Use suitable Motion Connect cables.

NOTICE**Damage caused by the use of unsuitable DRIVE-CLiQ cables**

If unsuitable DRIVE-CLiQ cables are used, damage or malfunctions can occur in the devices or the system itself.

- Use only appropriate DRIVE-CLiQ cables that have been approved by Siemens for the use case in question.

Note**Functional faults caused by dirty DRIVE-CLiQ interfaces**

Malfunctions can occur in the system due to use of dirty DRIVE-CLiQ interfaces.

- Close any unused DRIVE-CLiQ interfaces with the supplied cover plates.

Note

Function equipotential bonding for distributed DRIVE-CLiQ nodes

Integrate all of the components that are connected via DRIVE-CLiQ into the function equipotential bonding concept. The connection should be preferably established by mounting on metallic bright machine and plant components that are connected with one another using an equipotential bonding conductor.

Alternatively, you can establish equipotential bonding using a conductor (min. 6 mm²), which as far as possible, is routed parallel to the DRIVE-CLiQ cable.

This applies to all distributed DRIVE-CLiQ nodes such as DME20, SME2x, SME12x, etc.

7.3 Interface description

7.3.1 General interface overview

Table 7- 2 Interface overview classified according to terminal

Terminal	CU305 PN	CU305 DP	CU305 CAN
Specific interfaces			
X150 P1 / X150 P2	PROFINET	-	-
X126	-	PROFIBUS	CAN
Identical interfaces			
X100	DRIVE-CLiQ		
X124	Electronics power supply		
X130	Fail-safe digital inputs		
X131	Fail-safe digital inputs/outputs		
X132	Digital inputs/outputs, analog input		
X133	Digital inputs, temperature sensor input		
X23	Encoder interface (HTL/TTL/SSI)		
X22	Serial interface (RS232)		
X520 / X521 / X522	Measuring sockets		

7.3.2 CU305 PN (PROFINET)

7.3.2.1 Overview

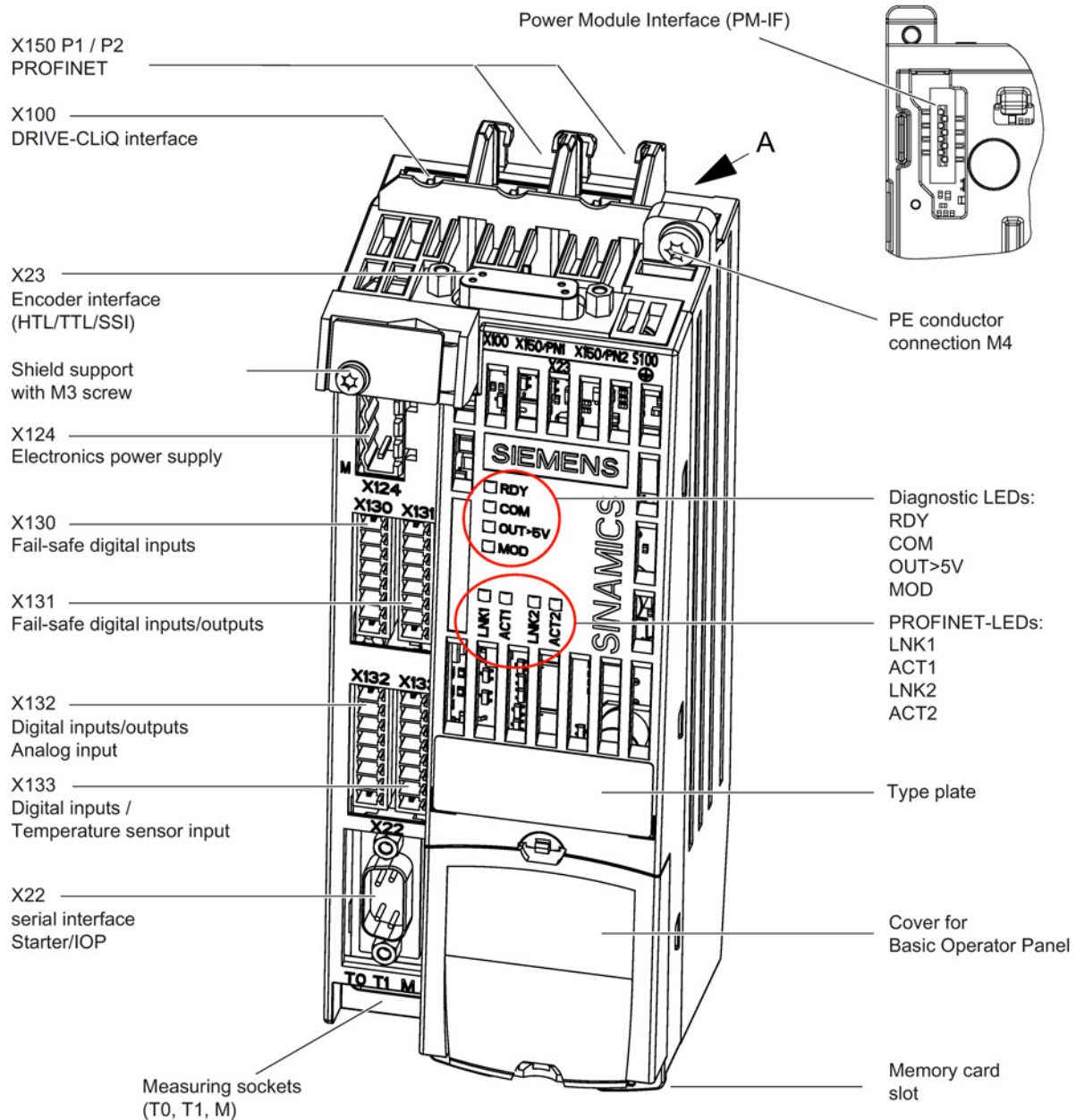

Figure 7-1 Interface overview for CU305 PN

Note

The address switches, which are located beneath the cover for the Basic Operator Panel BOP, have no function for the CU305 PN.

7.3.2.2 X150 P1 / P2 PROFINET

Table 7- 3 X150 P1 and X150 P2 PROFINET

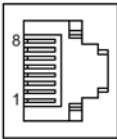
	Pin	Signal name	Technical data
	1	RXP	Receive data +
	2	RXN	Receive data -
	3	TXP	Transmit data +
	4	Reserved, do not use	-
	5	Reserved, do not use	-
	6	TXN	Transmit data -
	7	Reserved, do not use	-
	8	Reserved, do not use	-
Connector type:	RJ45 socket		
Data rate:	100 Mbits or 10 Mbits		

Note

The PROFINET interfaces support Auto MDI(X). It is therefore possible to use both crossed and uncrossed cables to connect the devices.

There are four LEDs on the front panel of the CU305 PN to display status information about the PROFINET interfaces (see Interface overview (Page 133)). The table shows the status information these indicate.

Table 7- 4 LED states on the X150 P1/P2 PROFINET interface

LED	Color	Status	Description
LNKx	-	Off	Missing or faulty link
	Green	Flashing light 0.5 Hz	Connection establishment
		Continuous light	10 or 100 Mbit link available
ACTx	-	Off	No activity
	Yellow	Flashing light	Data is being received or sent at port x

7.3.3 CU305 DP (PROFIBUS)

7.3.3.1 Overview

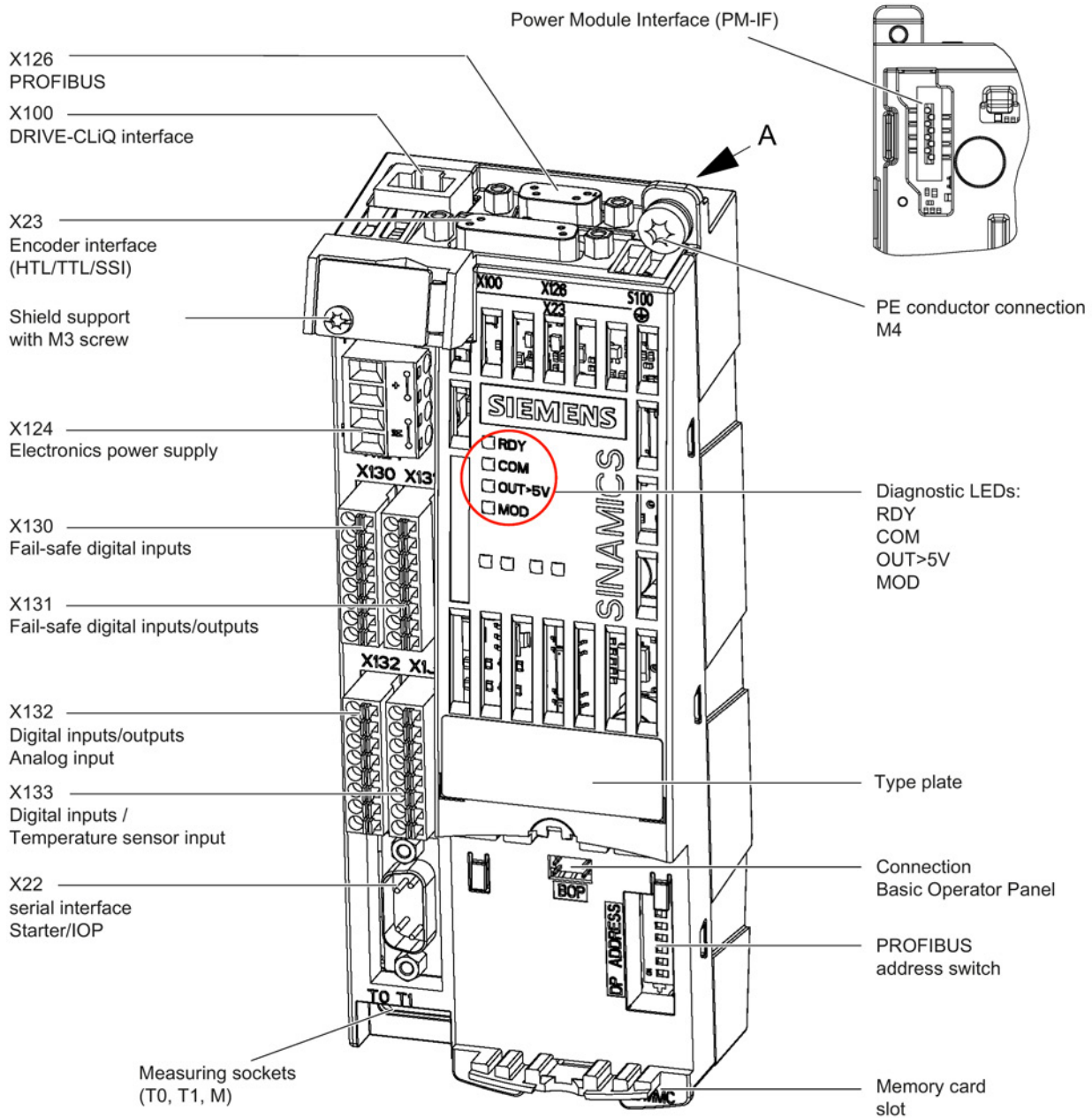
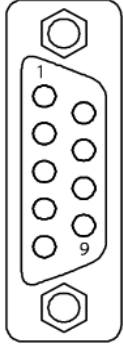

Figure 7-2 Description of the CU305 DP interfaces (ports)

7.3.3.2 X126 PROFIBUS/USS interface

Table 7- 5 X126 PROFIBUS/USS interface

	Pin	Signal name	Technical data
	1	Reserved, do not use	
	2	M	Ground to P24_SERV
	3	1RS_DP	RS485 differential signal
	4	1RTS_DP	Request To Send
	5	1M	Ground to 1P5
	6	1P5	5 V power supply for bus terminal, external, short circuit-proof
	7	P24_SERV	24 V for teleservice, short circuit-proof, 150 mA max.
	8	1XRS_DP	RS485 differential signal
	9	Reserved, do not use	

Type: 9-way Sub-D socket

NOTICE

Destruction of the CU305 DP when a CAN cable is connected

When a CAN cable is connected to the X126 interface, the CU305 DP or other CAN bus node can be irreparably damaged.

- Do not connect any CAN cable to the X126 interface.

Communication with USS protocol via RS485

Interface X126 can also be used for communication with USS involving up to 32 nodes. The STARTER software is used to change the PROFIBUS factory setting to USS. For operation as a USS interface, only terminals 3, 5, and 8 are used.

You will find information on configuration in the SINAMICS S110 Function Manual.

7.3.3.3 PROFIBUS/USS address switch

With the CU305 DP, the address switch can be used to set both PROFIBUS addresses and USS addresses. Operation via USS is only possible if the factory setting in the STARTER of PROFIBUS is changed to USS.

The factory setting for the address switch is 0 or 127. The address switch is located behind the blanking plate. The blanking plate is part of the scope of supply.

Table 7- 6 PROFIBUS/USS address switch

Technical data	Switch	Significance
<p>Significance: 2^0 2^1 2^2 2^3 2^4 2^5 2^6 1 2 4 8 16 32 64</p> <p>S1 S2 S3 S4 S5 S6 S7</p> <p>ON OFF</p> <p>Example: $2 + 4 + 8 + 16 = 30$ PROFIBUS/USS address = 30</p>	S1	$2^0 = 1$
	S2	$2^1 = 2$
	S3	$2^2 = 4$
	S4	$2^3 = 8$
	S5	$2^4 = 16$
	S6	$2^5 = 32$
	S7	$2^6 = 64$

Setting the PROFIBUS address

- Setting via the corresponding parameters (see SINAMICS S110 List Manual)
 - The STARTER is used to set the bus address for a PROFIBUS node to a value between 1 and 126. This is only possible if the address switch is set to 0 or 127 (factory setting).
- Manual setting
 - The address switch (DIP switch) is used to manually set the bus address to a value between 1 and 126. In this case, the parameter is only used to read the address.

Setting the USS address

- Setting via the corresponding parameters (see SINAMICS S110 List Manual)
 - The STARTER is also used to set the bus address for USS nodes to a value between 0 and 30. This is only possible if the address switch is set to 0 or 127 (factory setting).
- Manual setting
 - The address switch (DIP switch) is used to manually set the address to a value between 0 and 30. If addresses are set manually to values >30, the setting will revert to the value set in the parameter or the default value.

Note

A value of 0 is used as the address for USS if no other address has been saved in the parameter.

7.3.4 CU305 CAN

7.3.4.1 Overview

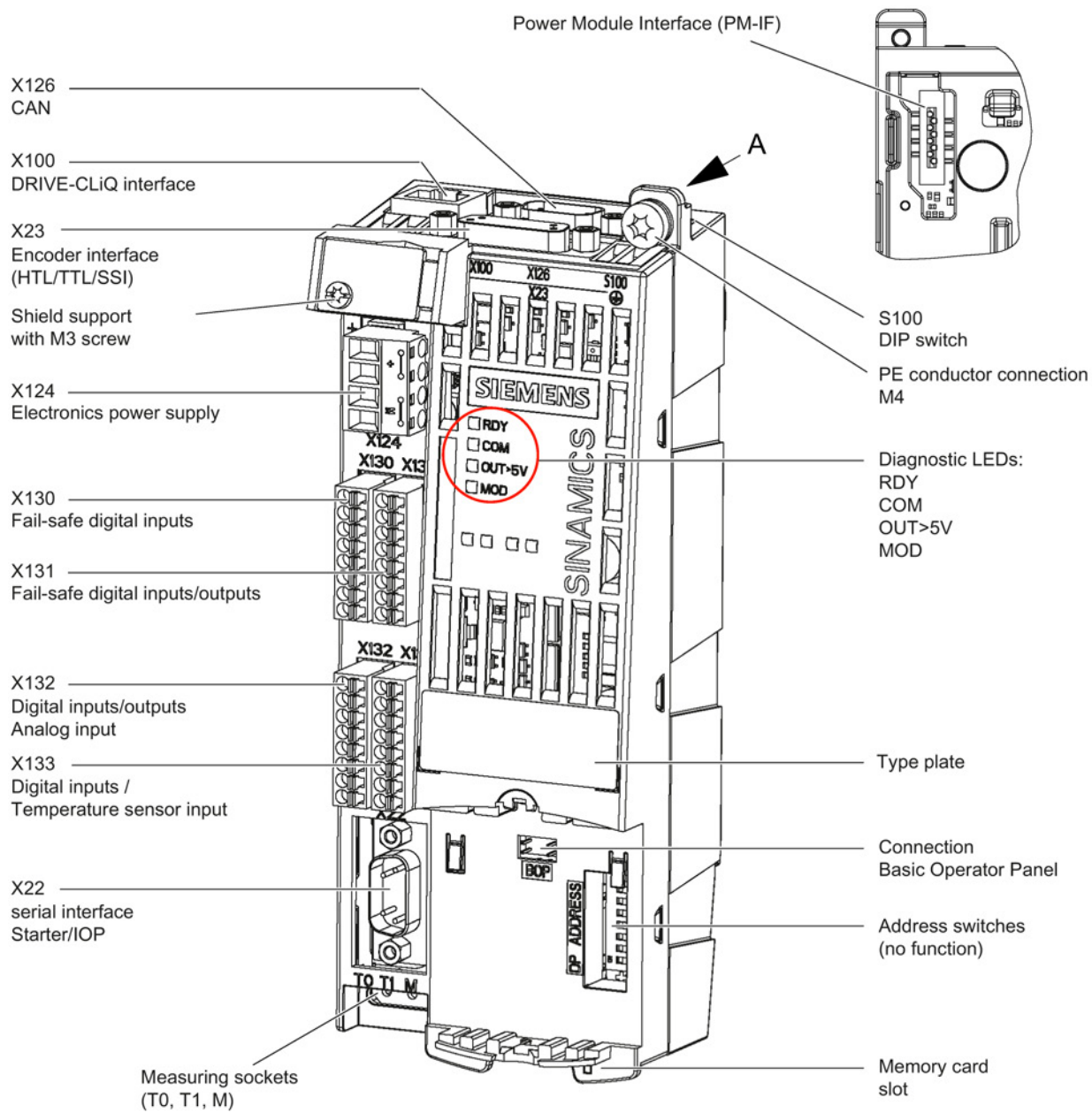
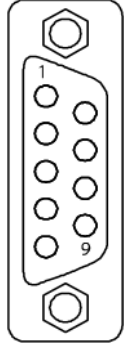

Figure 7-3 Interface description CU305 CAN

7.3.4.2 X126 CAN interface

Table 7- 7 X126 CAN interface

	Pin	Signal name	Technical data
	1	Reserved, do not use	
	2	CAN_L	CAN signal
	3	CAN_GND	CAN ground
	4	Reserved, do not use	
	5	CAN_SHL	Optional shield
	6	CAN_GND	CAN ground
	7	CAN_H	CAN signal
	8	Reserved, do not use	
	9	Reserved, do not use	

Type: 9-way Sub-D socket

NOTICE

Damage to the CAN interface if a PROFIBUS connector is connected

If a PROFIBUS connector is connected to the CAN interface, the interface may be damaged.

- Do not connect a PROFIBUS connector to the CAN interface.

7.3.4.3 S100 DIP switch

Table 7- 8 DIP switch

Switch	Function	Switch setting		Default
2	Bus terminating resistor 120 Ohm	Off	Inactive	Off
		On	Active	
1	Operation with/without ground	Off	Ungrounded operation	Off
		On	Grounded operation	

7.3.5 Identical interfaces for CU305 PN / DP / CAN

7.3.5.1 X22 serial interface (RS232)

Table 7- 9 X22 serial interface (RS232)

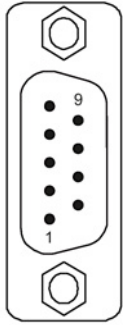
	Pin	Signal name	Technical data
	1	Reserved, do not use	
	2	RxD	Receive data
	3	TxD	Transmit data
	4	Reserved, do not use	
	5	Ground	Ground reference
	5	Reserved, do not use	
	6	Reserved, do not use	
	7	Reserved, do not use	
	8	Reserved, do not use	
9	Reserved, do not use		
Connector type	9-pin SUB D connector		

7.3.5.2 X23 HTL/TTL/SSI encoder interface

Table 7- 10 X23 HTL/TTL/SSI encoder connection

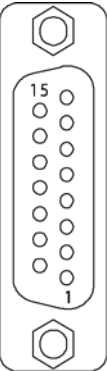
	Pin	Signal name	Technical data
	1	+Temp	KTY or PTC input
	2	SSI_CLK	SSI clock, positive
	3	SSI_XCLK	SSI clock, negative
	4	P_Encoder 5 V / 24 V	Encoder power supply
	5	P_Encoder 5 V / 24 V	Encoder power supply
	6	P_Sense	Sense input of encoder power supply
	7	M	Ground for encoder power supply
	8	M (- Temp)	Ground for KTY or PTC
	9	M_Sense	Ground sense input
	10	RP	R track positive
	11	RN	R track negative
	12	BN	B track negative
	13	BP	B track positive
	14	AN_SSI_XDAT	A track negative / SSI data negative
	15	AP_SSI_DAT	A track positive / SSI data positive
Connector type	15-pin sub D connector		
Measuring current via temperature sensor connection: 2 mA			

Temperature sensor input

There are two ways of connecting the temperature sensor:

1. via X133, terminals 7 and 8
2. via X23, pins 1 and 8

However, only one temperature sensor may be connected as otherwise the parallel circuit will be sensed and incorrect temperature values will be generated.

NOTICE
Damage to motor due to incorrectly connected KTY temperature sensor
If a KTY temperature sensor is connected with incorrect polarity, it is not possible to detect when the motor overheats. Overheating can cause damage to the motor.
<ul style="list-style-type: none">• Connect a KTY temperature sensor with the correct polarity.

Encoder connection

We always recommend that bipolar encoders are used.

When using unipolar encoders the unused negative track signals can either be left unconnected or connected to ground. This results in different switching thresholds.

Table 7- 11 Specification, measuring systems that can be connected

Parameter	Designation	Unit	Threshold	Min.	Type	Max.
Permissible signal level in bipolar mode ¹⁾ ; (TTL, SSI, HTL bipolar at X23) ²⁾³⁾	U _{diff}	V		2.0		V _{CC}
Permissible signal frequency	f _s	kHz		-		500
Required edge clearance	t _{min}	ns		100		-
Permissible zero pulse (with T _s = 1/f _s)	Length			¼ · T _s		¾ · T _s
	Center of the pulse position	Degrees		50	135	220
Switching threshold in the unipolar mode ¹⁾ and signals AN_SSI_XDAT, BN, RN at X23 connected to M_Encoder	U _(Switch)	V	High ⁴⁾	8.4	10.6	13.1
		V	Low ⁴⁾	3.5	4.8	6.3
Operating points in unipolar mode ¹⁾ and signals AN_SSI_XDAT, BN, RN not connected to X23	U _(Switch)	V	High ⁴⁾	9	11.3	13.8
		V	Low ⁴⁾	5.9	7.9	10.2

- 1) For the relevant parameters for setting the mode, see the SINAMICS S110 List Manual
- 2) Other signal levels according to the RS422 specification.
- 3) The absolute level of the individual signals varies between 0 V and V_{CC} of the measuring system.
- 4) For the relevant parameters for setting the switching threshold, see the SINAMICS S110 List Manual

Note

Prefabricated cable for 5 V TTL encoder

If a 5 V TTL encoder (6FX encoder) is used, the connecting cable 6FX8002-2CR00-.... has to be used.

Table 7- 12 Maximum encoder cable length

Encoder type	Maximum encoder cable length in m
TTL ¹⁾	100
HTL unipolar ²⁾	100
HTL bipolar	300

1) 100 m with remote sense

2) Because the physical transmission media is more robust, the bipolar connection should always be used. The unipolar connection should only be used if the encoder type does not output push-pull signals.

Connection example 1: HTL encoder, bipolar, with reference signal

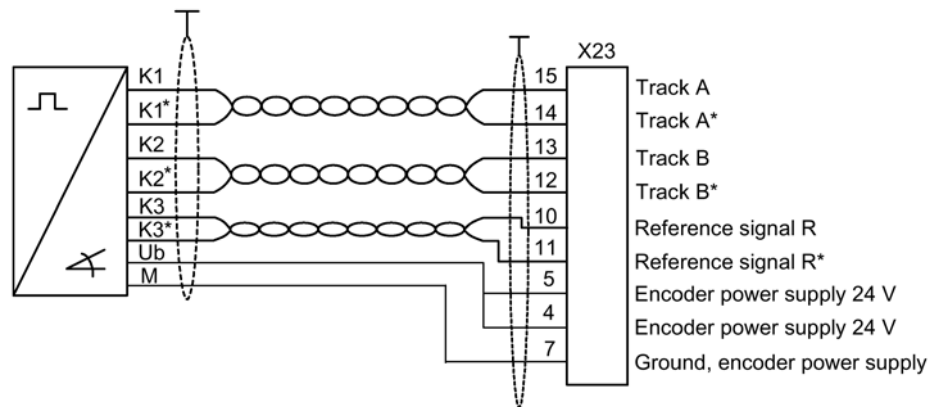

Figure 7-4 Connection example 1: HTL encoder, bipolar, with reference signal

Signal cables must be twisted in pairs in order to improve noise immunity against induced noise.

Connection example 2: HTL encoder, unipolar, with reference signal

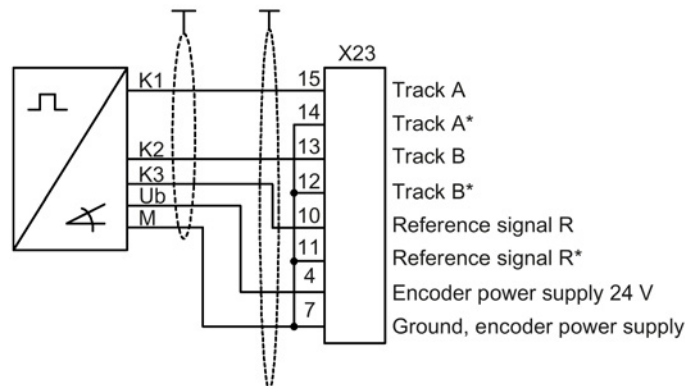

Figure 7-5 Connection example 2: HTL encoder, unipolar, with reference signal ¹⁾

¹⁾ Because the physical transmission media is more robust, the bipolar connection should always be used. The unipolar connection should only be used if the encoder type does not output push-pull signals.

7.3.5.3 Pulse/direction interface

Setpoint value specification with HTL level

Thanks to the pulse/direction interface, SINAMICS S110 can be used for simple positioning tasks on a controller. Connection to the controller is via internal encoder interface X23 of the CU305.

The controller gives the drive two signals: A pulse sequence with a pulse/pause ratio of 50:50 and a directional signal.

Table 7- 13 Setpoint value specification with HTL level

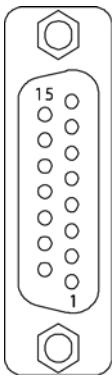
	Pin	Signal name	Technical data
	1 ... 6	Not relevant	–
	7	M	Ground
	8 ... 12	Not relevant	–
	13	BP Pulse/direction interface: Direction	B track positive
	14	Not relevant	–
	15	AP_DAT Pulse/direction interface: Pulse	A track positive
Type: 15-pin SUB D connector			

The required settings for the pulse/direction interface need to be made in the STARTER. Please refer to the SINAMICS S110 Function Manual for details.

Connection example

The image below shows an example of how to connect a pulse/direction interface with HTL level to interface X23 of a Control Unit CU305.

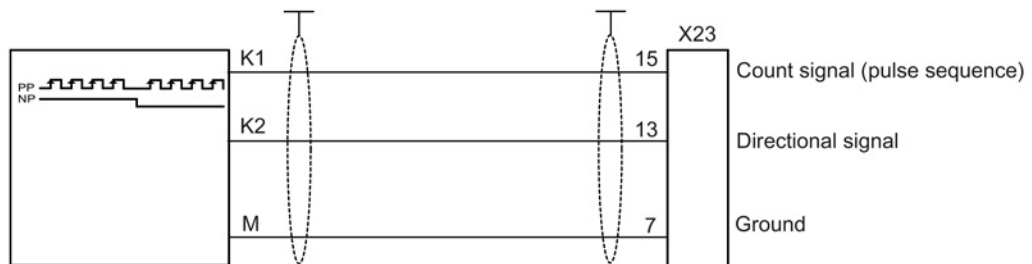
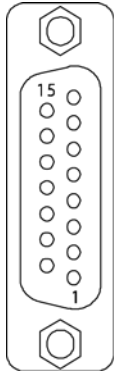

Figure 7-6 Connection of a pulse/direction interface with HTL level to interface X23

Setpoint value specification: Sensor signal with TTL level

This sections shows an example of how to connect bipolar TTL encoders to the pulse/direction interface of Control Unit CU305. Connection to the controller supports setpoint value specification via A track and B track.

Table 7- 14 Setpoint value specification: Sensor signal with TTL level

	Pin	Signal name	Technical data
	1 ... 6	Not relevant	–
	7	M	Ground
	8 ... 11	Not relevant	–
	12	Setpoint value specification, sensor signal	B track negative
	13		B track positive
	14	Setpoint value specification, sensor signal	A track negative
	15		A track positive
Type: 15-pin SUB D connector			

The required settings for the pulse/direction interface need to be made in the STARTER. Please refer to the SINAMICS S110 Function Manual for details.

Connection example

The image below shows an example of how to connect TTL encoders to interface X23 of a Control Unit CU305 for setpoint value specification via A track and B track.

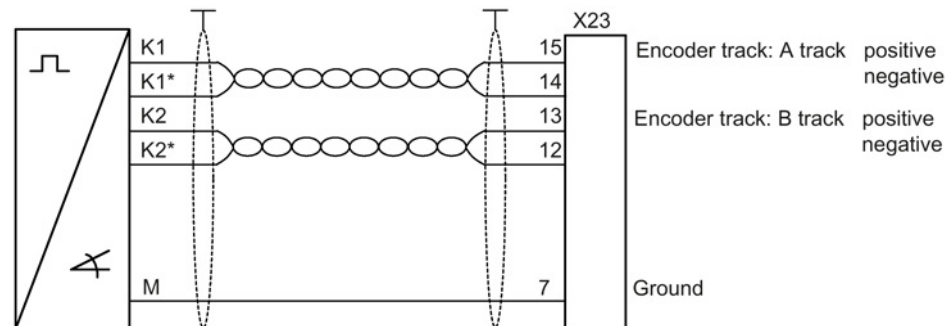
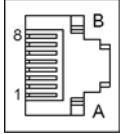

Figure 7-7 Connection of TTL encoders to interface X23 for setpoint value specification via A track and B track

7.3.5.4 X100 DRIVE-CLiQ interface

Table 7- 15 X100 DRIVE-CLiQ interface

	Pin	Signal name	Technical data	
	1	TXP	Transmit data +	
	2	TXN	Transmit data -	
	3	RXP	Receive data +	
	4	Reserved, do not use		
	5	Reserved, do not use		
	6	RXN	Receive data -	
	7	Reserved, do not use		
	8	Reserved, do not use		
	A	+ (24 V)	Power supply	
	B	M (0 V)	Electronics ground	
	Connector type	DRIVE-CLiQ socket		

The blanking cover for the DRIVE-CLiQ port is included in the scope of delivery.
 Blanking covers (50 x) Article No.: 6SL3066-4CA00-0AA0

Note

The maximum DRIVE-CLiQ cable length is 100 m.

7.3.5.5 X124 Electronics power supply

Table 7- 16 X124 electronics power supply

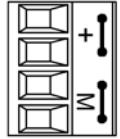
	Terminal	Function	Technical data
	+	Electronics power supply	Voltage: 24 V DC (20.4 to 28.8 V) Current consumption: max. 0.8 A (incl. 0.35 A for HTL encoders, without DRIVE-CLiQ and digital outputs) Max. current via jumper in connector: 20 A (15 A according to UL/CSA)
	+	Electronics power supply	
	M	Electronics ground	
	M	Electronics ground	
Type: Screw-type terminal (Page 263) Max. cross section that can be connected: 2.5 mm ²			

The maximum cable length that can be connected is 30 m.

Note

The two "+" or "M" terminals are jumpered in the connector. This ensures that the supply voltage is looped through.

Note

An additional external electronics power supply via terminal X124 is required in two cases:

- if digital outputs are used DO 8 to DO 11
- If the CU305 is to remain functional after the Power Module has been switched off

7.3.5.6 X130 fail-safe digital inputs

Table 7- 17 X130 fail-safe digital inputs

	Terminal	Designation ¹⁾	Technical data
	1	DI 16	F-DI 0 Voltage: -3 ... 30 V DC Input characteristics in accordance with IEC61131-2, type 1
	2	DI 17+	
	3	DI 17-	
	4	DI 18	F-DI 1 Typical current consumption: 6 mA at 24 V DC Electrical isolation: The reference potential is terminal M1 Permissible level (incl. ripple) High level: 15 ... 30 V Low level: -3 ... 5 V
	5	DI 19+	
	6	DI 19-	
	7	24 V1	Additional external power supply for interconnecting DI 16 / DI 18 with ground M1 See also Connection example, CU305 with safety function (Page 154)
	8	M1	Reference potential for the fail-safe digital inputs/outputs
Type: Spring-loaded terminal (Page 263) Max. cross section that can be connected: 1.5 mm ²			

¹⁾ DI: Digital input, F-DI: Fail-safe digital input

The maximum cable length that can be connected is 30 m.

Fail-safe digital inputs

An F-DI consists of two digital inputs. The cathode of the optocoupler is additionally connected to one of these.

Note

An open input is interpreted as "low."

Note

If M1 is connected to M (X124 or X132), the system is no longer electrically isolated.

7.3.5.7 X131 fail-safe digital inputs/outputs

Table 7- 18 X131 digital input and fail-safe digital inputs/outputs

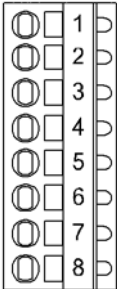
	Terminal	Designation ¹⁾	Technical data
	1	DI 20	F-DI 2 Input characteristics in accordance with IEC61131-2, type 1 Typical current consumption: 6 mA at 24 V DC
	2	DI 21+	
	3	DI 21-	
	4	DI 22	F-DO 0 Maximum load current: 500 mA Max. leakage current: 0.5 mA Short-circuit protected load types: resistive, capacitive, inductive Switching frequency: with inductive load: Max. 0.5 Hz Maximum lamp load: 2 W DO 16+: Switching to P potential DO 16-: Switching to N potential
	5	DO 16+	
	6	DO 16-	
	7	24 V1	
	8	M1	Additional external power supply for DO 16+, terminal X131/5. See also Example of circuits for the F-DI/F-DO... (Page 154)
Type: Spring-loaded terminal (Page 263) Max. cross section that can be connected: 1.5 mm ²			Electrical isolation: The reference potential is terminal M1 Permissible level (incl. ripple) High level: 15 ... 30 V Low level: -3 ... 5 V Reference potential for the fail-safe digital inputs/outputs

¹⁾ DI: digital input, DO: Digital output; F-DI: Fail-safe digital input; (F-DO) Fail-safe digital output

The maximum cable length that can be connected is 30 m.

An F-DI consists of two digital inputs. The cathode of the optocoupler is additionally connected to one of these.

The F-DO comprises two digital outputs each connected with an external 24 V supply.

Note

The fail-safe digital output (DO 16+, DO 16-) switches off retentively in the event of a short-circuit.

7.3.5.8 X132 digital inputs/outputs, analog input

Table 7- 19 X132 bidirectional digital inputs/outputs and analog input

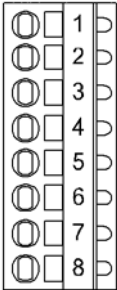
	Terminal	Designation ¹⁾	Technical data
	1	DI/DO 8	As input: input characteristics in accordance with IEC 61131-2, type 1 All digital inputs are floating. The reference potential is M. Typical current consumption: 7 mA at 24 V DC Level (incl. ripple) High level: 15 ... 30 V Low level: -3 ... 5 V DI 8, 9, 10, and 11 are "rapid inputs" ²⁾ Signal propagation times: For "0" → "1": 4 μs For "1" → "0": approx. 4 μs
	2	DI/DO 9	
	3	DI/DO 10	
	4	DI/DO 11	
	5	M	Reference potential for the digital inputs/outputs and the analog input
	6	M	
	7	AI +	Differential input voltage: -10 ... 10 V Maximum resolution range: -12.5 ... 12.5 V Common-mode range: -15 ... 15 V Resolution: 13 bit (referred to max. resolution range)
	8	AI -	
Type: Spring-loaded terminal (Page 263) Max. cross section that can be connected: 1.5 mm ²			

¹⁾ DI/DO: bidirectional digital input/output, AI: analog input; M: Electronics ground

²⁾ The rapid inputs can be used as inputs for measuring input or as inputs for the external zero mark

The maximum cable length that can be connected is 30 m.

Note

The common mode range may not be violated. This means that the analog differential voltage signals can have a maximum offset voltage of ±15 V with respect to the reference potential. If the range is infringed, incorrect results may occur during analog/digital conversion.

Note

An open input is interpreted as "low."

Note

A 24 V supply must be connected to terminal X124 so that the digital outputs can be used.
 If the 24 V supply is interrupted, the digital outputs are deactivated, i.e. switched to "0," during this time.

7.3.5.9 X133 digital inputs/temperature sensor input

Table 7- 20 X133 digital inputs/temperature sensor input

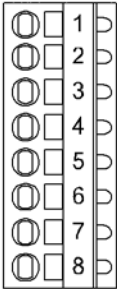
	Terminal	Designation ¹⁾	Technical data
	1	DI 0	Input characteristic curve in accordance with IEC 61131-2, type 1
	2	DI 1	
	3	DI 2	Typical current consumption: 6 mA at 24 V DC Electrical isolation: The reference potential is terminal M2 Permissible level (incl. ripple) High level: 15 ... 30 V Low level: -3 ... 5 V
	4	DI 3	
	5	M2	Reference potential M2
	6	M2	
	7	+ Temp	Motor temperature measurement KTY84-1C130 (KTY+) Temperature sensor connection KTY84-1C130 / PTC
	8	M (- Temp)	Ground for KTY or PTC
Type: Spring-loaded terminal (Page 263) Max. cross section that can be connected: 1.5 mm ² Measuring current via the temperature sensor connection: 2 mA			

¹⁾ DI: Digital input

The maximum cable length that can be connected is 30 m.

Note

An open input is interpreted as "low."

Temperature sensor input

There are two ways of connecting a temperature sensor:

1. Via X133, terminals 7 and 8
2. Via X23, pins 1 and 8

However, only one temperature sensor may be connected as otherwise the parallel circuit will be sensed and incorrect temperature values will be generated.

NOTICE
Damage to motor due to incorrectly connected KTY temperature sensor
If a KTY temperature sensor is connected with incorrect polarity, it is not possible to detect when the motor overheats. Overheating can cause damage to the motor.
<ul style="list-style-type: none"> • Connect a KTY temperature sensor with the correct polarity.



! WARNING
Danger to life due to electric shock in the event of voltage flashovers on the temperature sensor cable
Voltage flashovers in the signal electronics can occur in motors without safe electrical separation of the temperature sensors.
<ul style="list-style-type: none"> • Only use temperature sensors that fully comply with the specifications of the safety isolation. • If safe electrical separation cannot be guaranteed (for linear motors or third-party motors, for example), use a Sensor Module External (SME120 or SME125) or Terminal Module TM120.

7.3.5.10 X520/X521/X522 test sockets

Table 7- 21 X520, X521, X522 test sockets

Socket	Function	Technical data
T0	Measuring socket 0	Voltage: 0 ... 5 V Resolution: 8 bits Load current: max. 3 mA Continued-short-circuit-proof
T1	Measuring socket 1	
M	Ground for measuring sockets	
The measuring sockets are only suitable for bunch pin plugs with a diameter of 2 mm.		

Note

The measuring sockets support commissioning and diagnostic functions. It must not be connected for normal operation.

7.3.5.11 Slot for the memory card

A memory card is needed in the following cases:

1. Saving parameters
Parameters are saved on the memory card and can simply be copied onto the new CU305 if the component needs to be replaced.
2. Firmware update
It is easy to perform a firmware update using a memory card.
3. License carrier
The license is stored on the memory card.

Note

The CU305 can be operated without the memory card. The memory card only needs to be inserted into the CU305 because it is the license carrier for the Safety functions.

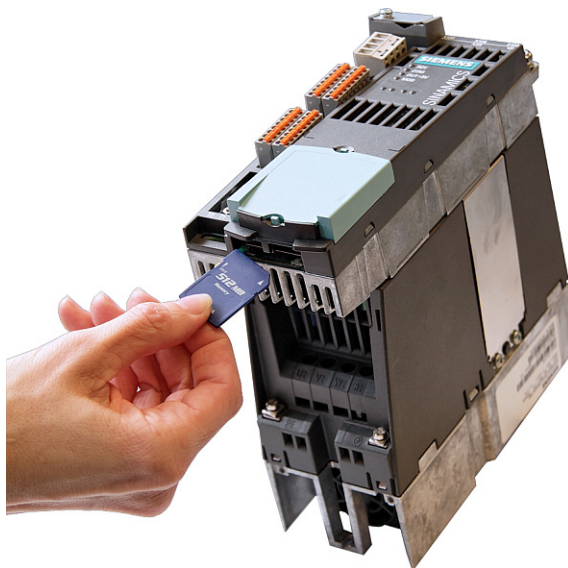

Figure 7-8 Memory card slot

 **WARNING**

Danger to life due to software manipulation when using exchangeable storage media

Storing files on exchangeable storage media poses an increased risk of infection, e.g. with viruses and malware. Incorrect parameter assignment can cause machines to malfunction, which can lead to injuries or death.

- Protect files stored on exchangeable storage media from malicious software using appropriate protection measures, e.g. virus scanners.



NOTICE

Damage to memory card due to electric fields or electrostatic discharge

Electrical fields or electrostatic discharge may result in the memory card being damaged.

- When removing and inserting the memory card, always observe the ESD regulations.

The memory card may only be inserted as shown in the figure (arrow top right).

Working with the memory card

If you return a defective CU305 to Siemens, remove the memory card and keep it in a safe place.

When you commission the replacement device, all stored data (firmware, licenses, parameters) will be available to you again.

7.4 Connection examples

Connection examples without a safety function

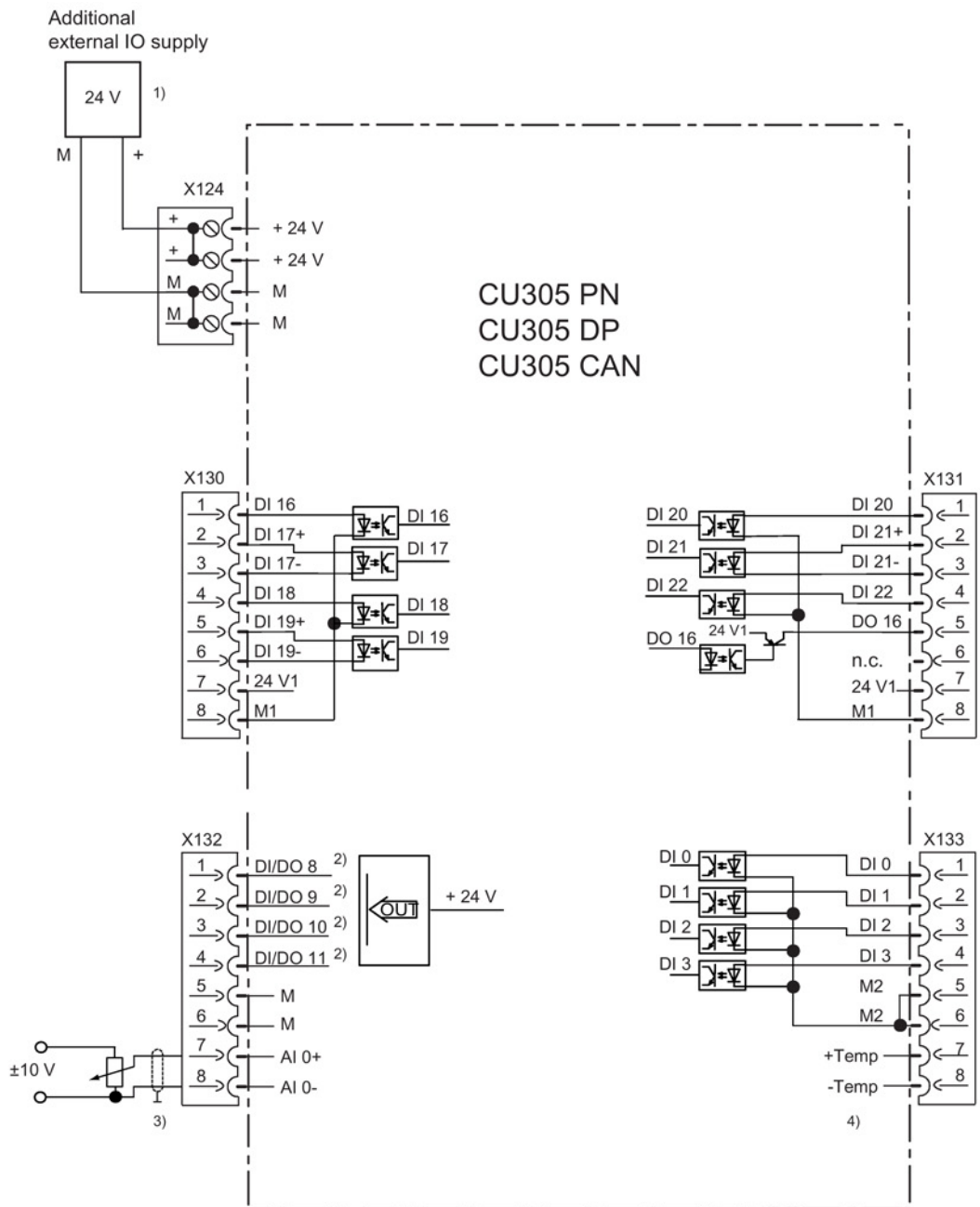

- 1) Necessary to power the digital outputs DO 8 to DO 11
- 2) Use shielded cables for fast inputs

- 3) Use shielded cables for analog input
- 4) Implement sensor input for motor temperature with shielding

Figure 7-9 Internal connections of the CU305 without the safety function

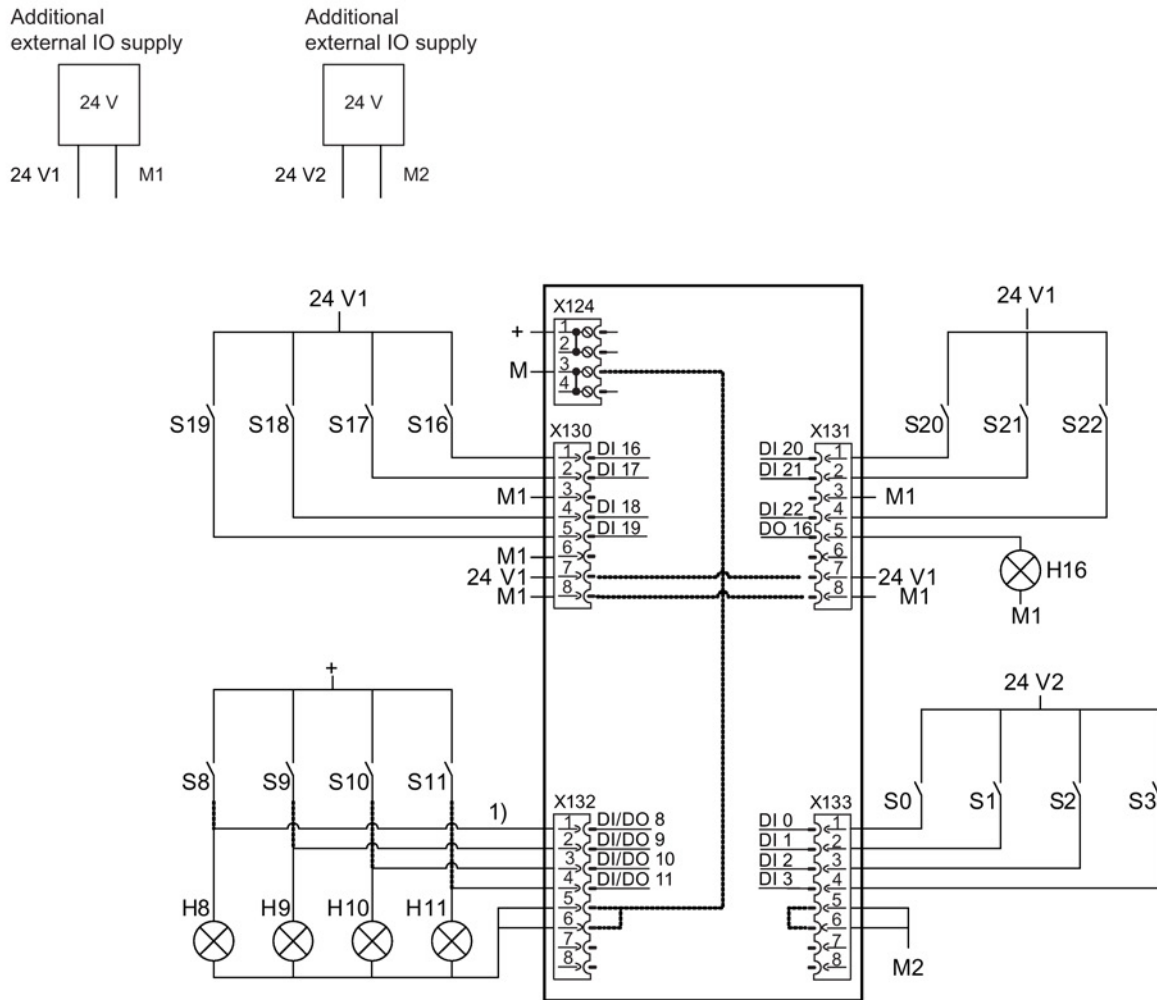

1) Function of terminals 1 - 4 can be input or output depending on parameter setting

Figure 7-10 Example of circuits for the DI/DO without the safety function

Connection example with a safety function

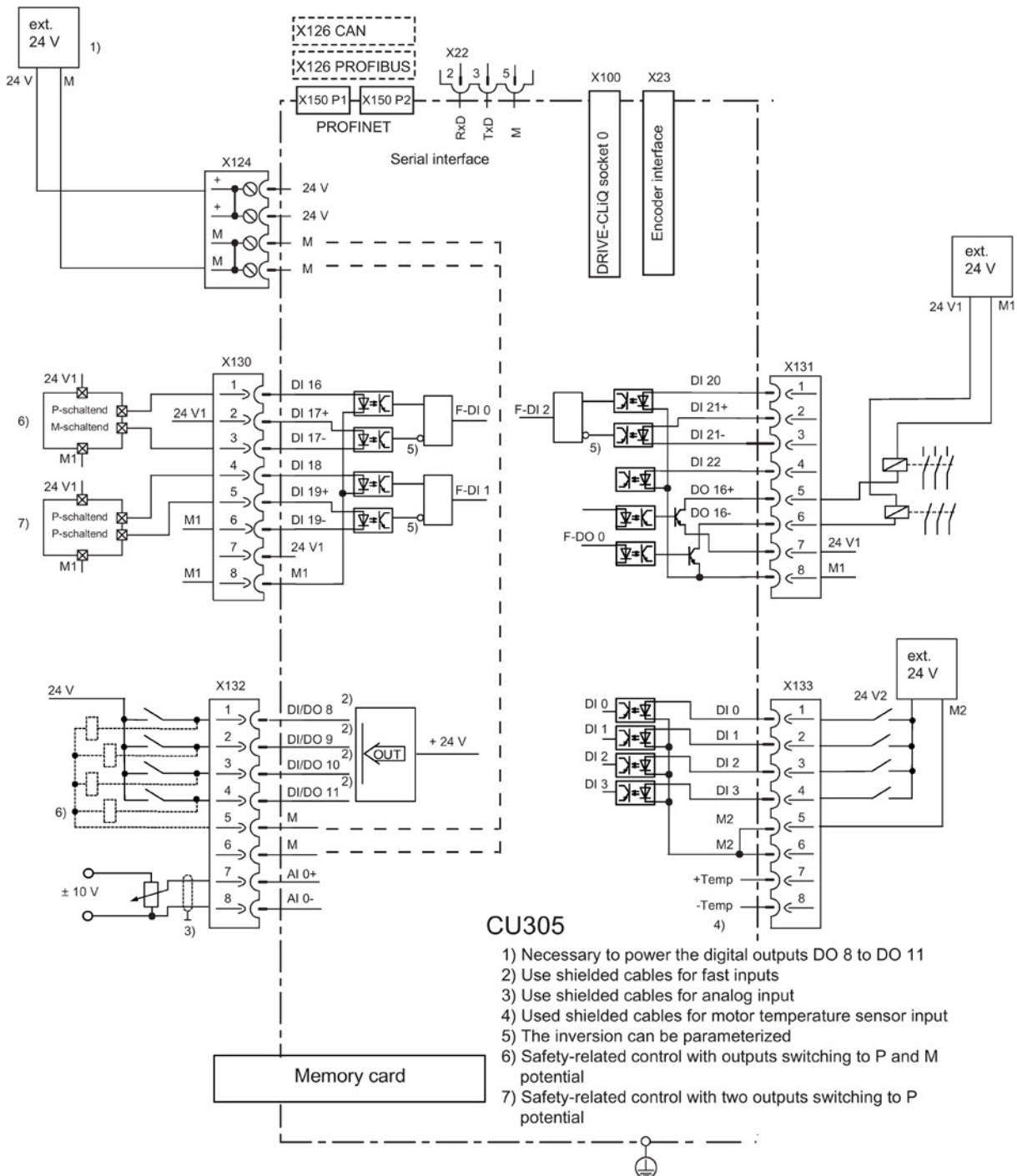

Figure 7-11 Connection example, CU305 with safety function

You will find more information about connections in the manual:
 SINAMICS S110 Function Manual, Drive Functions

7.5 Meaning of LEDs

There are four LEDs on the front panel of the CU305 housing.

RDY	Ready
COM	Status of the fieldbus communication
OUT>5V	Encoder current supply > 5 V (TTL/HTL)
MOD	Operating mode (reserved)

The various LEDs are switched on and off as the Control Unit is powered up (depending on the phase that the system is currently in). When switched on, the color of the LEDs shows the status of the corresponding power-up phase (see Reaction of the LEDs during power up (Page 158)).

In the event of a fault, power up will be ended in the corresponding phase. The LEDs that are switched on retain their color at this particular instant in time, so that the fault can be determined based on the combination of LEDs that are switched on (bright) and switched off (dark).

Once the CU305 has booted correctly, all the LEDs are switched off briefly. The system is ready to operate when the "RDY" LED lights up green permanently.

All the LEDs are controlled by the software loaded during operation (see Behavior of the LEDs in the operating state (Page 159)).

7.5.1 Reaction of the LEDs during power up

Loading

Table 7- 22 Load software

LED				Status	Comment
RDY	COM	OUT>5V	MOD		
Orange	Orange	OFF	Red	Reset	Hardware reset
Red	Red	OFF	OFF	BIOS loaded	-
Red 2 Hz	Red	OFF	OFF	BIOS error	Error occurred while loading the BIOS
Red 2 Hz	Red 2 Hz	OFF	OFF	File error	Memory card not inserted or defective Software on memory card not present or corrupted

Table 7- 23 Firmware

LED				Status	Comment
RDY	COM	OUT>5V	MOD		
Red	Orange	OFF	OFF	Firmware loading	COM-LED flashing without specific flashing frequency
Red	OFF	OFF	OFF	Firmware loaded	-
OFF	Red	OFF	OFF	Firmware check (no CRC error)	-
Red 0.5 Hz	Red 0.5 Hz	OFF	OFF	Firmware check (CRC error)	CRC is incorrect
Orange	OFF	OFF	OFF	Firmware initialization	-

Update

Table 7- 24 Firmware update from memory card

LED				Status	Comment
RDY	COM	OUT>5V	MOD		
Red	Orange	OFF	OFF	Firmware update	COM-LED flashing without specific flashing frequency
Red 2 Hz	Red	OFF	OFF	Firmware update failed	Check whether the memory card is inserted or replace the memory card.

LED				Status	Comment
RDY	COM	OUT>5V	MOD		
Red 0.5 Hz	Red 0.5 Hz	OFF	OFF	Firmware update complete, waiting for POWER ON	-
Red 2 Hz	Red	OFF	OFF	Firmware check (CRC error)	CRC is incorrect.
Red 2 Hz	Red 2 Hz	OFF	OFF	Firmware or memory card incompatible	Check the firmware version or memory card.

7.5.2 Behavior of the LEDs in the operating state

Table 7- 25 Control Unit CU305 - description of the LEDs in the operating state

LED	Color	Status	Description/cause	Remedy
RDY (READY)	-	Off	Electronics power supply is missing or outside permissible tolerance range.	Check the power supply
	Green	Continuous light	The unit is ready for operation. Cyclic DRIVE-CLiQ communication is in progress.	-
		Flashing light 0.5 Hz	Commissioning/reset	-
		Flashing light 2 Hz	Writing to the memory card.	-
	Red	2 Hz flashing light	General errors	Check parameter assignment/configuration.
	Red/green	0.5 Hz flashing light	The Control Unit is ready for operation, but there are no software licenses.	Install the missing licenses.
	Orange	0.5 Hz flashing light	Updating the firmware of the DRIVE-CLiQ components.	-
		2 Hz flashing light	DRIVE-CLiQ component firmware update completed. Waiting for POWER ON of the corresponding component.	Switch on the component.
	Green/Orange or Red/Orange	2 Hz flashing light	Recognition of components via LED is activated ¹ . Note: Both options depend on the LED status when activated.	-

7.5 Meaning of LEDs

LED	Color	Status	Description/cause	Remedy
COM CU305 DP CU305 PN	-	Off	Cyclic communication is not (yet) running. Note: The PROFIdrive is ready for communication when the Control Unit is ready for operation (see LED: RDY).	-
	Green	Continuous light	Cyclic communication is taking place.	-
		0.5 Hz flashing light	Full cyclic communication is not yet in progress. ²⁾	-
	Red	0.5 Hz flashing light	The PROFIBUS master is sending a faulty parameter assignment or the configuration is incorrect.	Modify the configuration between master/controller and Control Unit.
2 Hz flashing light		Cyclic bus communication has been interrupted or could not be established	Rectify the bus communication fault.	
COM CU305 CAN	-	Off	Electronics power supply is missing or outside permissible tolerance range. Communication board defective or not inserted.	-
	Green	Continuous light	OPERATIONAL	-
		2.5 Hz flashing light	PREOPERATIONAL No PDO communication possible.	-
		Single flash	STOPPED Only NMT communication possible.	-
	Red	Continuous light	BUS OFF	Check the baud rate and cabling.
		Single flash	ERROR PASSIVE MODE The error counter for "error passive" has reached the value 127.	Check the baud rate and cabling.
Double flash		Error Control Event A guard event has occurred.	Check the connection to CANopen master.	
OUT > 5 V	-	Off	-	-
	Orange	Continuous light	The voltage of the electronics power supply for the measuring system is 24 V. ³⁾	-
MOD	-	Off	Operating state (reserved)	-

1) For activation of component recognition via LED, see the SINAMICS S110 List Manual

2) Possible causes:

- The controller is not transferring any setpoints.
- For isochronous operation, there is either no GC (Global Control) transferred from the controller, or it has an error.

3) Only encoders that are rated for a voltage of 24 V must be connected.

NOTICE

Damage to the 5-V encoder when connecting to 24 V

Connecting a 5 V encoder to a 24 V supply can result in damage to the encoder electronics.

- Only connect an encoder to 24 V that is rated for a voltage of 24 V.

7.6 Dimension drawings

7.6.1 Dimension drawing, CU305 PN

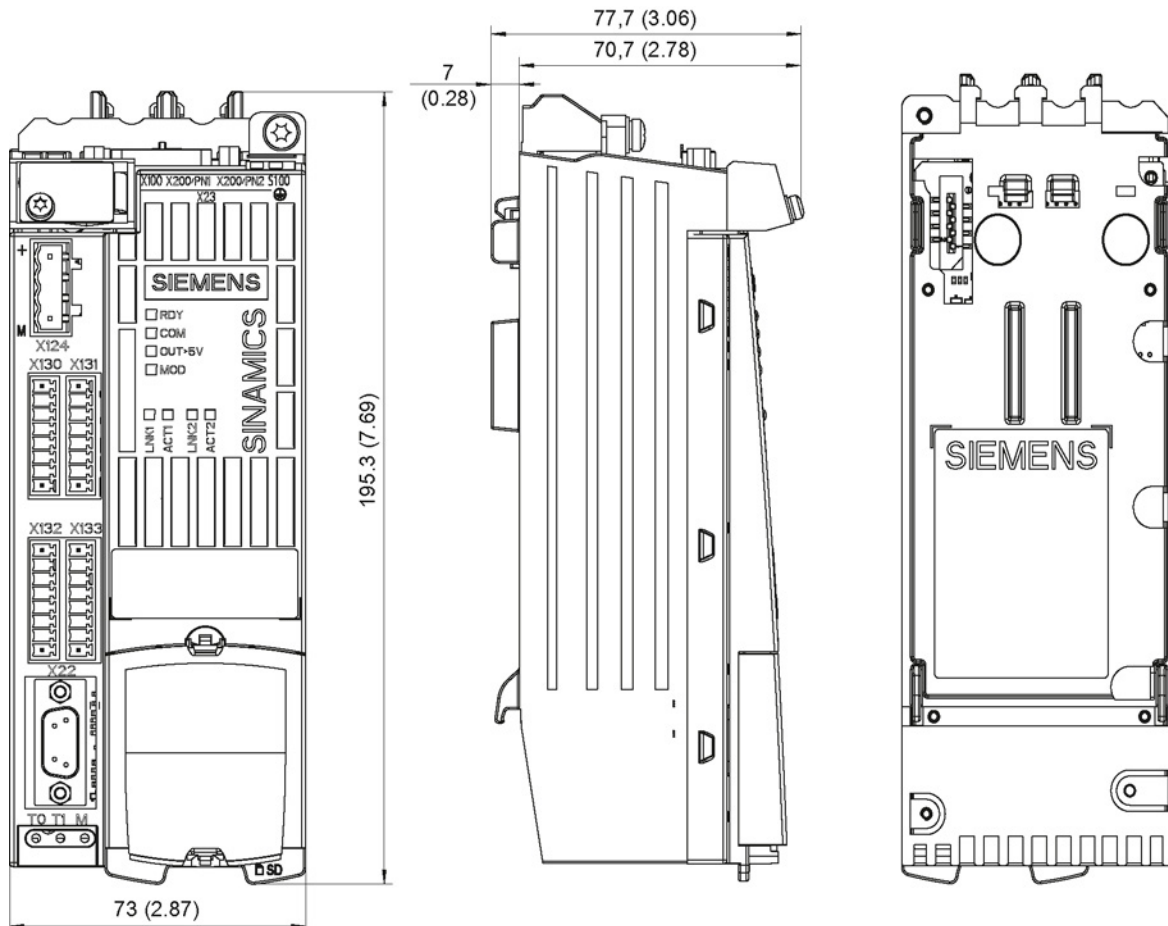

Figure 7-12 Dimension drawing of Control Unit CU305 PN, all data in mm and (inches)

7.6.2 Dimension drawing CU305 DP/CAN

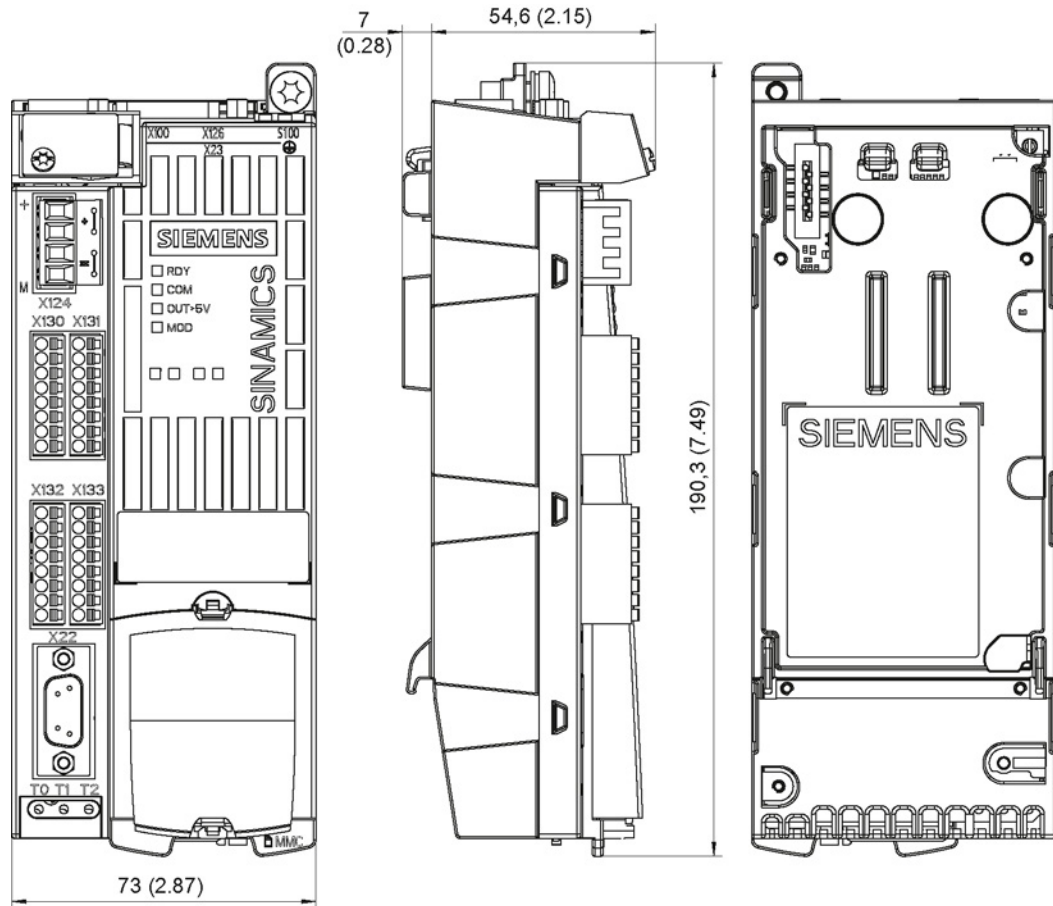
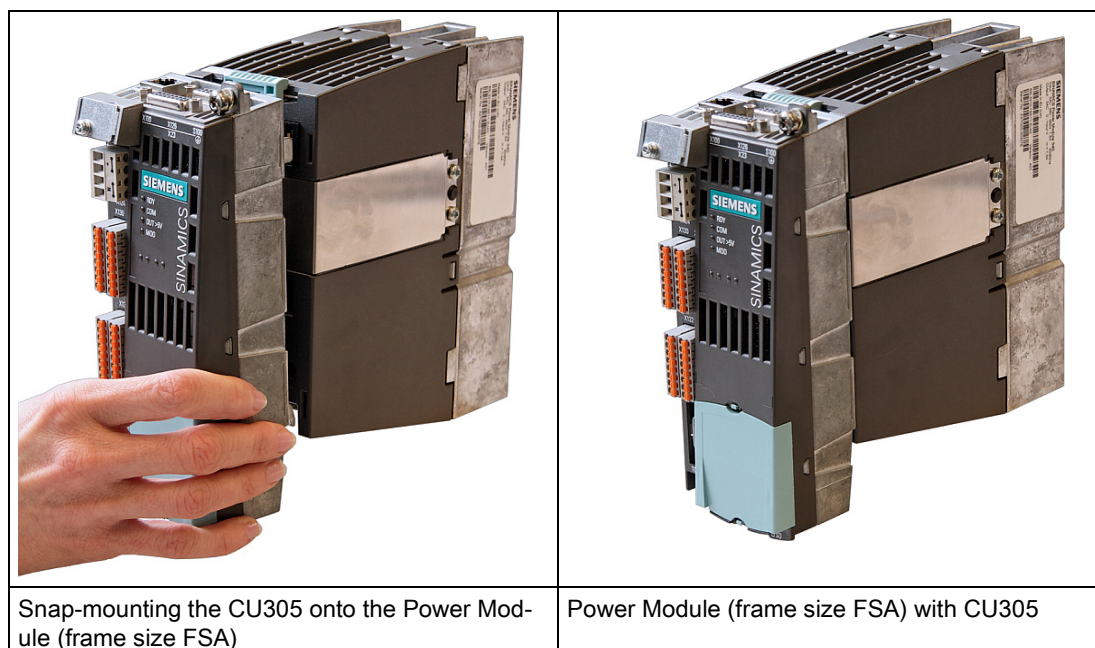

Figure 7-13 Dimension drawing of Control Unit CU305 DP and CU305 CAN, all data in mm and (inches)

7.7 Installation



The procedure when mounting the Control Unit on the Power Module is independent of the frame size of the Power Module.

Removing the Control Unit

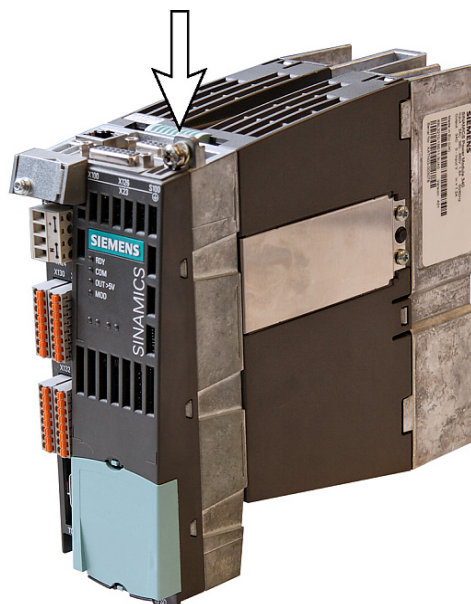

Figure 7-14 Removing the CU305 from the Power Module (frame size FSA)

To remove the Control Unit from the Power Module, press the blue release lever, shown in the diagram, downward and swing the Control Unit out to the front.

7.8 Technical data

Table 7- 26 Technical data for CU305 PN/DP/CAN

	Unit	Value
Electronics power supply		
Voltage	V _{DC}	24 (20.4 ... 28.8)
Current consumption (without DRIVE-CLiQ and digital outputs)	A _{DC}	0.8
Power loss	W	< 20
Measuring system power supply		
Voltage	V _{DC}	TTL: 5 V (with or without remote sense) HTL: V _{DC} - 1 V
Current	A _{DC}	0.35
PE/ground connection		On the housing with M4 screw Tightening torque: 3 Nm
Response time		The response time of digital inputs/outputs depends on the evaluation (see SINAMICS S110 List Manual, Function Diagrams).
Weight	kg	0.95

8.1 Basic Operator Panel BOP20

8.1.1 Description

The Basic Operator Panel BOP20 contains 6 keys and a backlit display unit. The BOP20 can be plugged onto a SINAMICS Control Unit and operated.

The following functions are possible with the BOP:

- Input of parameters and activation of functions
- Display of operating modes, parameters, alarms and faults

8.1.2 Interface description



Figure 8-1 Basic Operator Panel BOP20

Overview of displays and keys

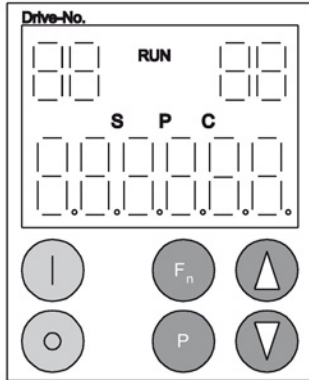







Figure 8-2 Overview of displays and keys

Table 8- 1 Displays

Display	Meaning
Top left 2 positions	The active drive object of the BOP is displayed here. The displays and key operations always refer to this drive object.
RUN	Is lit (bright) if the displayed drive is in the RUN state (in operation).
Top right 2 positions	The following is displayed in this field: <ul style="list-style-type: none"> • More than 6 digits: Characters that are present but cannot be seen (e.g. "r2" → 2 characters to the right are invisible, "L1" → 1 character to the left is invisible) • Faults: Selects/displays other drives with faults • Designation of BICO inputs (bi, ci) • Designation of BICO outputs (bo, co) Source object of a BICO interconnection to a drive object other than the active one.
S	Is (bright) if at least one parameter was changed and the value was not transferred into the non-volatile memory.
P	Is lit (bright) if, for a parameter, the value only becomes effective after pressing the P key.
C	Is light (bright) if at least one parameter was changed and the calculation for consistent data management has still not been initiated.
Below, 6 position	Displays, e.g. parameters, indices, faults and alarms.

BOP20 keyboard

Table 8- 2 Assignment of the BOP20 keyboard

Key	Name	Meaning
	ON	Powering-up the drives for which the command "ON/OFF1", "OFF2" or "OFF3" should come from the BOP.
	OFF	Power-down the drives for which the "ON/OFF1," "OFF2," or "OFF3" commands should come from the BOP.
		<p>Note:</p> <p>The effectiveness of these keys can be defined using the appropriate BICO parameterization (e.g. using these keys, it is possible to simultaneously control all of the axes that have been configured.)</p> <p>The structure of the BOP control word corresponds to the structure of the PROFIBUS control word.</p>
	Functions	<p>The meaning of these keys depends on the actual display.</p> <p>Note:</p> <p>The effectiveness of this key to acknowledge faults can be defined using the appropriate BICO parameterization.</p>
	Parameter	The meaning of these keys depends on the actual display.
	Raise	The keys are dependent on the actual display and are used to raise or lower values.
	Lower	

8.1.3 Installation

NOTICE

Damage to the interface for the BOP20 at the Control Unit through tilting

If the BOP20 is skewed when inserting or withdrawing it, this can damage the interface for the BOP20.

- Make sure that you insert and withdraw the BOP20 straight into/out of the Control Unit and that it is not tilted up or down.

Mounting

The photographs show how to mount the Basic Operator Panel BOP20 on a CU305.



1. BOP20 and Control Unit CU305



2. Press the latching cams of the cover together simultaneously.

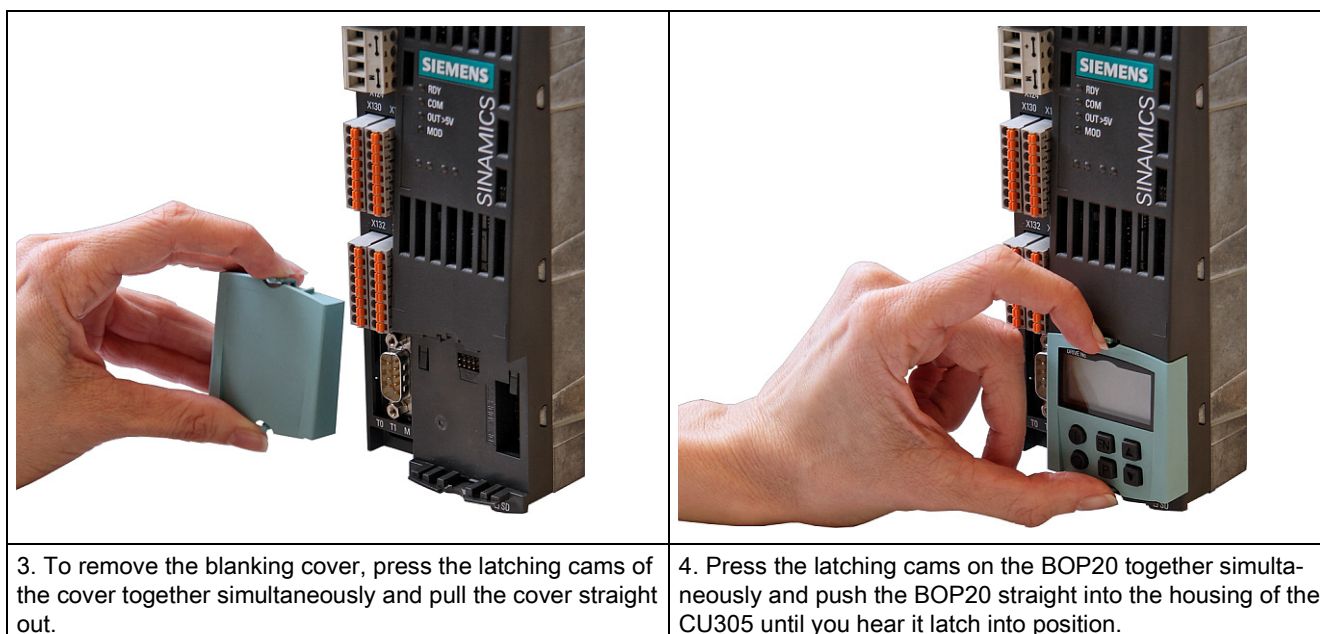

Note

The BOP20 may be inserted into or withdrawn from the Control Unit while the Control Unit is in operation.

Removal

1. Press the latching cams of the BOP20 together simultaneously.
2. Keep the latching cams pressed together and pull the BOP20 straight out.
3. Insert the blanking cover.

Displays and operator controls of the BOP20

You will find information on the displays and operator controls of the BOP20 in the SINAMICS S110 Function Manual.

8.2 Sensor Module Cabinet-Mounted SMC10

8.2.1 Description

The Sensor Module Cabinet-Mounted SMC10 is an expansion module for snapping on to a standard mounting rail acc. to EN 60715. It evaluates encoder signals and transmits the speed, actual position value, rotor position and, if necessary, the motor temperature via DRIVE-CLiQ to the Control Unit.

The SMC10 is used to evaluate sensor signals from resolvers.

8.2.2 Safety instructions for Sensor Modules Cabinet-Mounted

 WARNING
Danger to life if the fundamental safety instructions and residual risks are not heeded
Failure to heed the fundamental safety instructions and residual risks in Chapter 1 can result in accidents causing severe injuries or death.
<ul style="list-style-type: none">• Follow the fundamental safety instructions.• Consider the residual risks on the risk assessment.



 WARNING
Danger to life due to electric shock when disconnecting and connecting encoder cables during operation
When opening plug connections in operation, arcs can result in severe injury or death.
<ul style="list-style-type: none">• Disconnect or connect the encoder cables to Siemens motors, which are not expressly released for connecting and disconnecting during operation, in a deenergized condition only.• When using direct measuring systems (third-party encoders), ask the manufacturer whether hot-plugging is permitted.

 WARNING
Danger to life due to fire if overheating occurs because of insufficient ventilation clearances
Inadequate ventilation clearances can cause overheating of components with subsequent fire and smoke. This can cause severe injury or even death. Further, increased failures can occur and the service life of units/systems may be shortened.
<ul style="list-style-type: none">• For this reason, ensure the 50-mm ventilation clearances above and below the Sensor Module Cabinet-Mounted.

NOTICE

Damage when connecting an impermissible number of encoder systems

If more than the maximum permissible number of encoder systems are connected to a Sensor Module, this will cause damage.

- Only connect one encoder system per Sensor Module.

NOTICE

Damage caused by the use of incorrect DRIVE-CLiQ cables

The use of incorrect or not released DRIVE-CLiQ cables can cause damage or functional faults to devices or the system.

- Use only appropriate DRIVE-CLiQ cables that have been approved by Siemens for the use case in question.

Note

Diminished level of interference immunity due to equalizing currents via the electronics ground

Ensure that there is no electrical connection between the encoder system housing and the signal cables, or the encoder system electronics. If this is not carefully observed, the system may not be able to reach the required interference immunity level. (There is then a danger of equalization currents flowing through the electronics ground.)

Note

Function equipotential bonding for distributed DRIVE-CLiQ nodes

Integrate all of the components that are connected via DRIVE-CLiQ into the function equipotential bonding concept. The connection should be preferably established by mounting on metallic bright machine and plant components that are connected with one another using an equipotential bonding conductor.

Alternatively, you can establish equipotential bonding using a conductor (min. 6 mm²), which as far as possible, is routed parallel to the DRIVE-CLiQ cable. This involves all distributed DRIVE-CLiQ nodes, for example, SMCxx.

Note

Functional faults caused by dirty DRIVE-CLiQ interfaces

Malfunctions can occur in the system due to use of dirty DRIVE-CLiQ interfaces.

- Close any unused DRIVE-CLiQ interfaces with the supplied cover plates.
-

8.2.3 Interface description

8.2.3.1 Overview

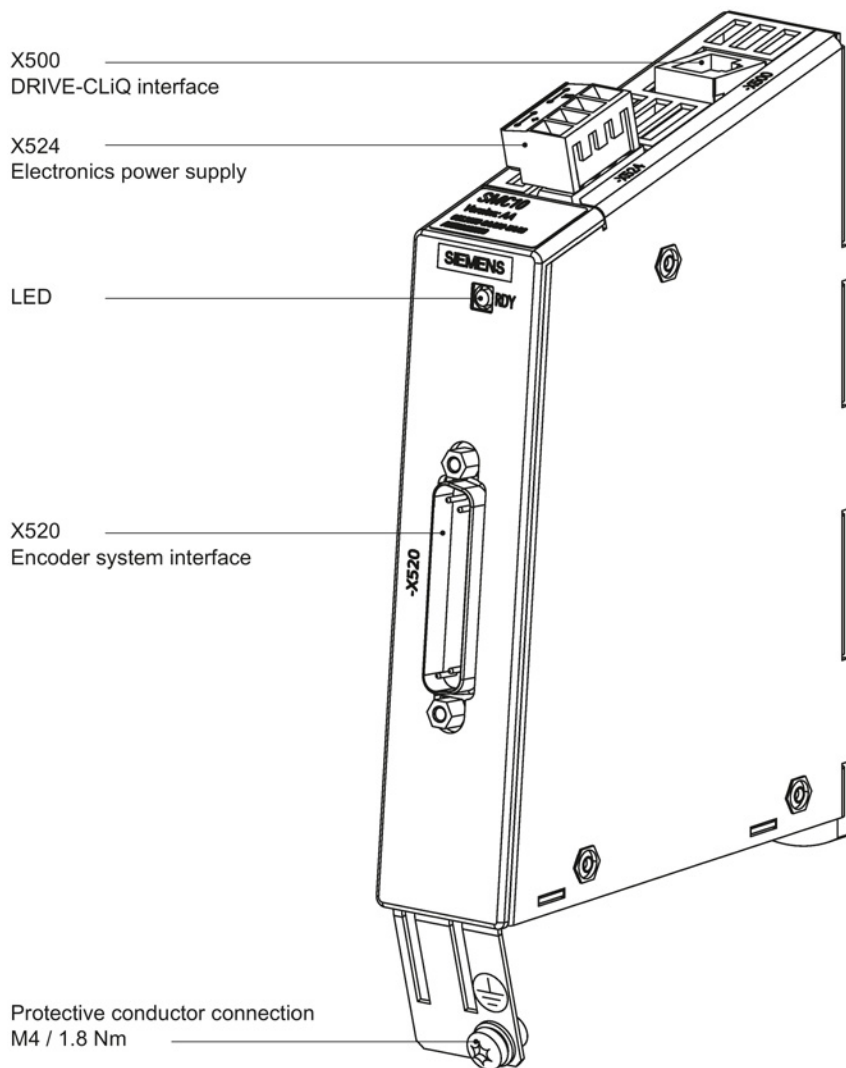
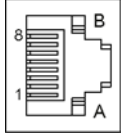

Figure 8-3 Interface overview for the SMC10

8.2.3.2 X500 DRIVE-CLiQ interface

Table 8- 3 X500: DRIVE-CLiQ interface

	Pin	Signal name	Technical data
	1	TXP	Transmit data +
	2	TXN	Transmit data -
	3	RXP	Receive data +
	4	Reserved, do not use	
	5	Reserved, do not use	
	6	RXN	Receive data -
	7	Reserved, do not use	
	8	Reserved, do not use	
	A	Reserved, do not use	
	B	M (0 V)	Electronics ground
	Connector type	DRIVE-CLiQ socket	

The blanking cover for the DRIVE-CLiQ port is included in the scope of delivery.

Blanking covers (50 x) Article No.: 6SL3066-4CA00-0AA0

8.2.3.3 X520 encoder system interface

Table 8- 4 X520: Encoder system interface

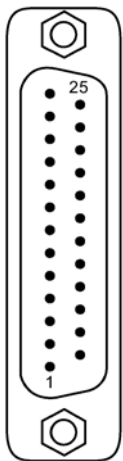
	Pin	Signal name	Technical data
	1	Reserved, do not use	
	2	Reserved, do not use	
	3	S2	Resolver signal A (sin+)
	4	S4	Inverted resolver signal A (sin-)
	5	Ground	Ground (for internal shield)
	6	S1	Resolver signal B (cos+)
	7	S3	Inverted resolver signal B (cos-)
	8	Ground	Ground (for internal shield)
	9	R1	Resolver excitation positive
	10	Reserved, do not use	
	11	R2	Resolver excitation negative
	12	Reserved, do not use	
	13	+ Temp ¹⁾	Motor temperature sensing KTY84-1C130 (KTY+) Temperature sensor KTY84-1C130 / PTC
	14	Reserved, do not use	
	15	Reserved, do not use	
	16	Reserved, do not use	
	17	Reserved, do not use	
	18	Reserved, do not use	
	19	Reserved, do not use	
	20	Reserved, do not use	
	21	Reserved, do not use	
	22	Reserved, do not use	
	23	Reserved, do not use	
	24	Ground	Ground (for internal shield)
	25	- Temp ¹⁾	Motor temperature sensing KTY84-1C130 (KTY-) Temperature sensor KTY84-1C130 / PTC
Connector type:	25-pin SUB D connector		
Measuring current via temperature sensor connection: 2 mA			

1) Accuracy of temperature measurement:
 - KTY: ±7 °C (incl. evaluation)
 - PTC: ±5 °C (incl. evaluation)

NOTICE

Damage to motor due to incorrectly connected KTY temperature sensor

If a KTY temperature sensor is connected with incorrect polarity, it is not possible to detect when the motor overheats. Overheating can cause damage to the motor.

- Connect a KTY temperature sensor with the correct polarity.



! WARNING

Danger to life due to electric shock in the event of voltage flashovers on the temperature sensor cable

Voltage flashovers in the signal electronics can occur in motors without safe electrical separation of the temperature sensors.

- Only use temperature sensors that fully comply with the specifications of the safety isolation.
- If safe electrical separation cannot be guaranteed (for linear motors or third-party motors, for example), use a Sensor Module External (SME120 or SME125) or Terminal Module TM120.

8.2.3.4 X524 Electronics power supply

Table 8- 5 X524: Electronics power supply

	Terminal	Function	Technical data
	+	Electronics power supply	Voltage: 24 V (20.4 ... 28.8 V) Current consumption: Max. 0.35 A Maximum current via jumper in connector: 20 A (15 A according to UL/CSA)
	+	Electronics power supply	
	M	Electronics ground	
	M	Electronics ground	
Type: Screw-type terminal (Page 263) Max. cross section that can be connected: 2.5 mm ²			

The maximum cable length that can be connected is 30 m.

Note

The two "+" or "M" terminals are jumpered in the connector. This ensures that the supply voltage is looped through.

8.2.4 Meaning of the LED

Table 8- 6 Meaning of the LED on the Sensor Module Cabinet-Mounted SMC10

LED	Color	Status	Description, cause	Remedy
RDY READY	-	Off	The electronics power supply is missing or outside the permissible tolerance range.	-
	Green	Continuous light	The component is ready for operation. Cyclic DRIVE-CLiQ communication is taking place.	-
	Orange	Continuous light	DRIVE-CLiQ communication is being established.	-
	Red	Continuous light	This component has at least one fault. Note: The LED is activated irrespective of whether the corresponding messages have been reconfigured.	Remove and acknowledge the fault.
	Green/ red	Flashing light 0.5 Hz	Firmware is being downloaded.	-
		Flashing light 2 Hz	Firmware download is complete. The system waits for POWER ON.	Carry out a POWER ON.
	Green/ orange or Red/ orange	Flashing light	Component recognition via LED is activated ¹⁾ . Note: Both options depend on the LED status when component recognition is activated.	-

¹⁾ See SINAMICS S110 List Manual for the parameters to activate component recognition via LED

Cause and rectification of faults

The following documents contain information about the cause of faults and how they can be rectified:

- SINAMICS S110, Function Manual
- SINAMICS S110, List Manual

8.2.5 Dimension drawing

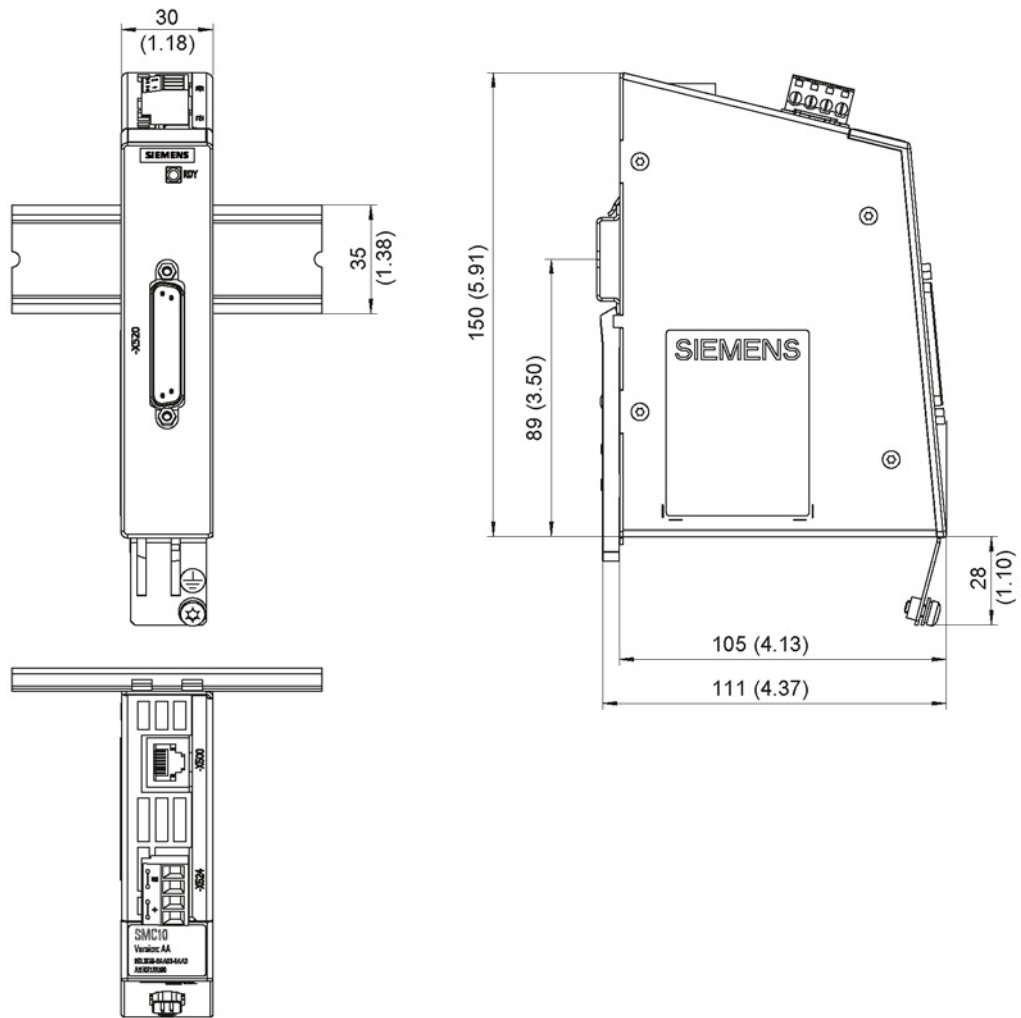

Figure 8-4 Dimension drawing of the Sensor Module Cabinet SMC10, all dimensions in mm and (inches)

8.2.6 Mounting

Installation

1. Tilt the component backwards slightly and attach it to the DIN rail using the hooks.
2. Swivel the component onto the DIN rail until you hear the mounting slide at the rear latch into position.
3. Slide the components along the mounting rail to either the left or right up to their final position.

Removal

1. First shift the mounting slide downwards at the lug to release the interlocking with the mounting rail.
2. Swivel the component to the front and withdraw it upwards from the DIN rail.

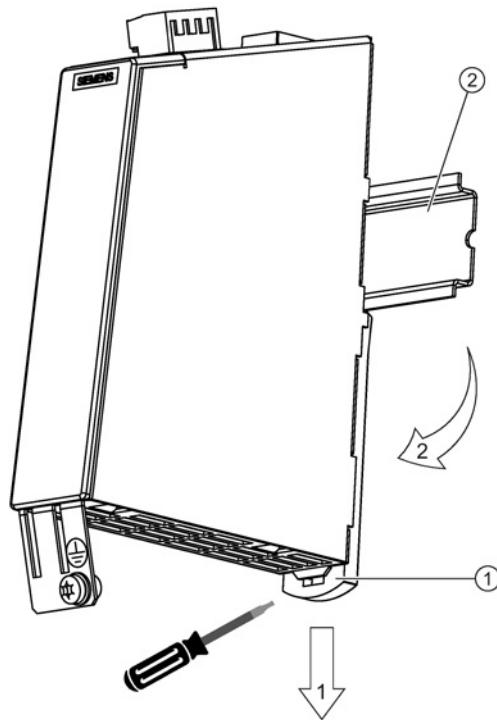

- ① Mounting slide
- ② Mounting rail

Figure 8-5 Removing from a DIN mounting rail

8.2.7 Technical data

Table 8- 7 Technical data

6SL3055-0AA00-5AAx	Unit	Value
Electronics power supply		
Voltage	V _{DC}	24 (20.4 ... 28.8)
Current (without encoder system)	A _{DC}	≤ 0.20
Current (with encoder system)	A _{DC}	≤ 0.35
Power loss	W	≤ 10
Max. Cable length	m	30
Specification		
Transformation ratio of the resolver (ü)		0.5
Excitation voltage on the SMC10 when ü=0.5	V _{rms}	4.1
Amplitude monitoring threshold (secondary tracks) of the SMC10	V _{rms}	1
Excitation voltage (cannot be parameterized)	V _{rms}	4.1
Excitation frequency (synchronized to the current controller clock cycle)	kHz	5 to 16
PE/ground connection	At the housing with M4/1.8 Nm screw	
Max. Encoder cable length	m	130
Weight	kg	0.45
Degree of protection		IP20 or IPXXB

Table 8- 8 Max. frequency that can be evaluated (speed)

Resolver		Max. Speed, resolver/motor		
Number of poles	Number of pole pairs	8 kHz / 125 µs	4 kHz / 250 µs	2 kHz / 500 µs
2-pole	1	120000 rpm	60000 rpm	30000 rpm
4-pole	2	60000 rpm	30000 rpm	15000 rpm
6-pole	3	40000 rpm	20000 rpm	10000 rpm
8-pole	4	30000 rpm	15000 rpm	7500 rpm

The ratio between the ohmic resistance R and the inductance L (the primary winding of the resolver) determines whether the resolver can be evaluated with the SMC10. See the following diagram:

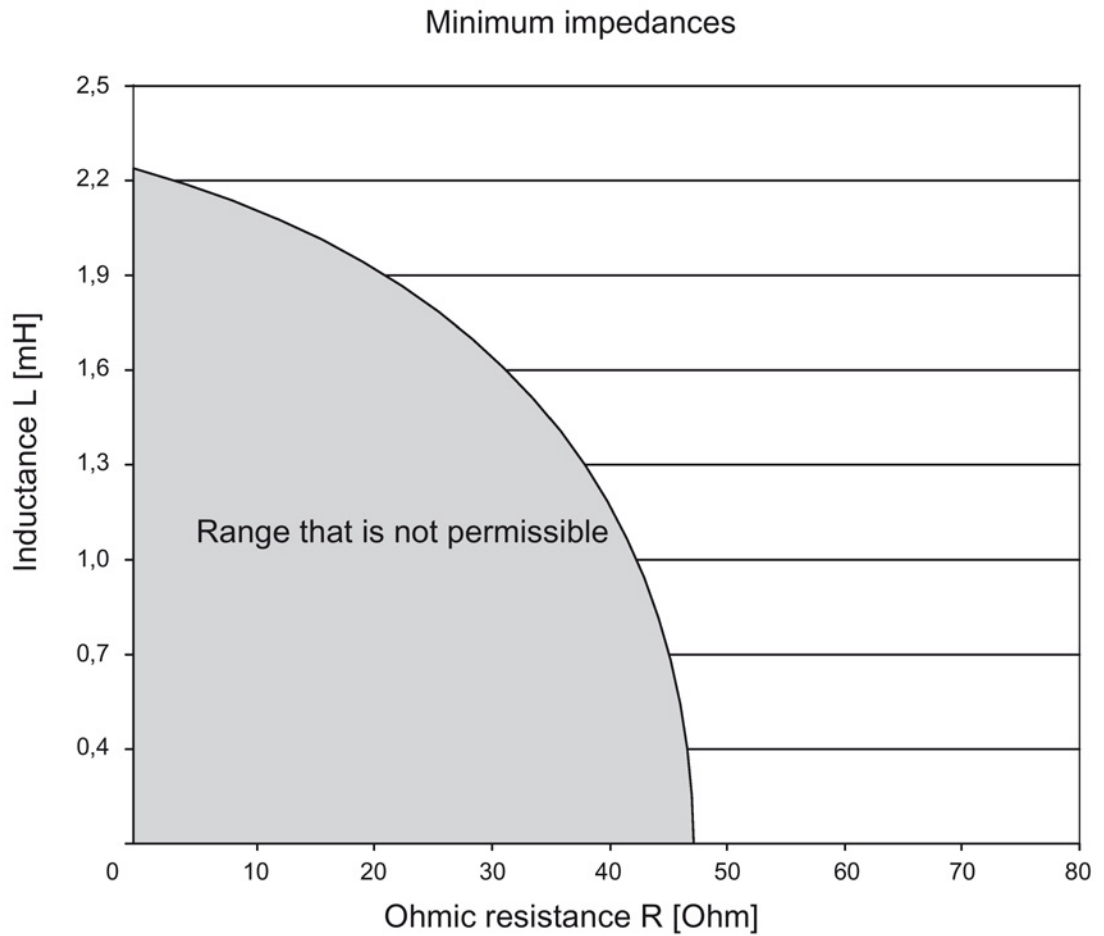

Figure 8-6 Rotor impedances that can be connected with excitation frequency $f = 5000$ Hz

To check as shown in the figure above, the impedances Z_{rs} or Z_{ro} (impedance between R1 and R2 with short-circuited or open outputs) from the encoder manufacturer's data sheet must be used.

8.3 Sensor Module Cabinet-Mounted SMC20

8.3.1 Description

The Sensor Module Cabinet-Mounted SMC20 is an expansion module for snapping on to a standard mounting rail acc. to EN 60715. It evaluates encoder signals and transmits the speed, actual position, rotor position and, if applicable, the motor temperature and reference point via DRIVE-CLiQ to the Control Unit.

The SMC20 is used to evaluate encoder signals from incremental encoders with SIN/COS (1 Vpp) or absolute encoders with EnDat 2.1. EnDat 2.2 order designation 02 or SSI.

8.3.2 Safety instructions for Sensor Modules Cabinet-Mounted

 WARNING
Danger to life if the fundamental safety instructions and residual risks are not heeded
Failure to heed the fundamental safety instructions and residual risks in Chapter 1 (Page 17) can result in accidents causing severe injuries or death.
<ul style="list-style-type: none">• Follow the fundamental safety instructions.• Consider the residual risks on the risk assessment.

 WARNING
Danger to life due to failure to heed the specific safety instructions for Sensor Modules
Failure to heed the Specific safety instructions for Sensor Modules (Page 170) can result in accidents causing severe injuries or death.
<ul style="list-style-type: none">• Heed the Specific safety instructions for Sensor Modules.

8.3.3 Interface description

8.3.3.1 Overview

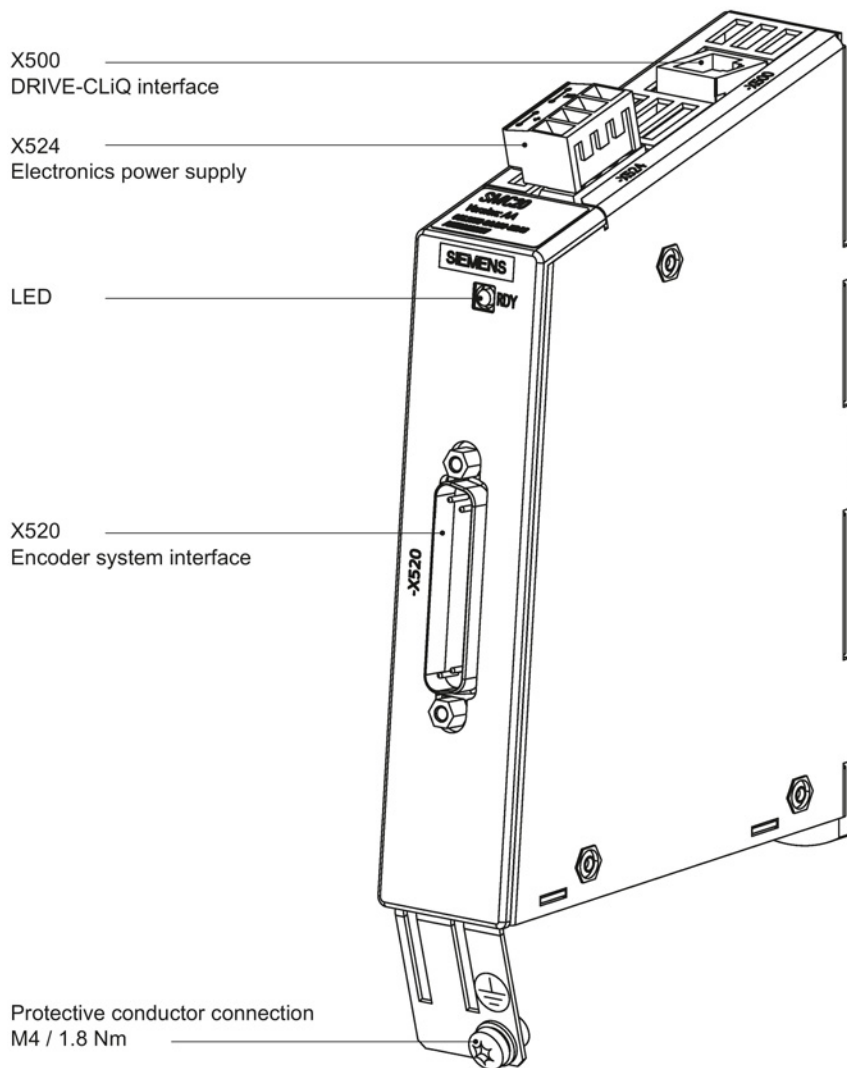
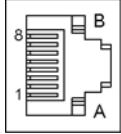

Figure 8-7 Interface description of the SMC20

8.3.3.2 X500 DRIVE-CLiQ interface

Table 8- 9 X500: DRIVE-CLiQ interface

	Pin	Signal name	Technical data
	1	TXP	Transmit data +
	2	TXN	Transmit data -
	3	RXP	Receive data +
	4	Reserved, do not use	
	5	Reserved, do not use	
	6	RXN	Receive data -
	7	Reserved, do not use	
	8	Reserved, do not use	
	A	Reserved, do not use	
	B	M (0 V)	Electronics ground
	Connector type	DRIVE-CLiQ socket	

The blanking cover for the DRIVE-CLiQ port is included in the scope of delivery.

Blanking covers (50 x) Article No.: 6SL3066-4CA00-0AA0

8.3.3.3 X520 encoder system interface

Table 8- 10 X520: Encoder system interface

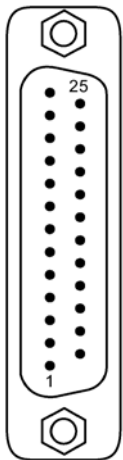
	Pin	Signal name	Technical data
	1	P encoder	Encoder power supply
	2	M encoder	Ground for encoder power supply
	3	A	Incremental signal A
	4	A*	Inverse incremental signal A
	5	Ground	Ground (for internal shield)
	6	B	Incremental signal B
	7	B*	Inverse incremental signal B
	8	Ground	Ground (for internal shield)
	9	Reserved, do not use	
	10	Clock	Clock, EnDat interface, SSI clock
	11	Reserved, do not use	
	12	Clock*	Inverted clock, EnDat interface, inverted SSI clock
	13	+Temp ¹⁾	Motor temperature sensing KTY84-1C130 (KTY+) Temperature sensor KTY84-1C130 / PTC
	14	P sense	Sense input of encoder power supply
	15	Data	Data, EnDat interface, SSI data
	16	M sense	Ground sense input encoder power supply
	17	R	Reference signal R
	18	R*	Inverse reference signal R
	19	C	Absolute track signal C
	20	C*	Inverse absolute track signal C
	21	D	Absolute track signal D
	22	D*	Inverse absolute track signal D
	23	Data*	Inverse data, EnDat interface, Inverse SSI data
	24	Ground	Ground (for internal shield)
	25	-Temp ¹⁾	Motor temperature sensing KTY84-1C130 (KTY-) Temperature sensor KTY84-1C130 / PTC
Connector type:	25-pin SUB D connector		
Measuring current via temperature sensor connection: 2 mA			

1) Accuracy of temperature measurement:
 - KTY: ±7 °C (incl. evaluation)
 - PTC: ±5 °C (incl. evaluation)

NOTICE

Damage to motor due to incorrectly connected KTY temperature sensor

If a KTY temperature sensor is connected with incorrect polarity, it is not possible to detect when the motor overheats. Overheating can cause damage to the motor.

- Connect a KTY temperature sensor with the correct polarity.



! WARNING

Danger to life due to electric shock in the event of voltage flashovers on the temperature sensor cable

Voltage flashovers in the signal electronics can occur in motors without safe electrical separation of the temperature sensors.

- Only use temperature sensors that fully comply with the specifications of the safety isolation.
- If safe electrical separation cannot be guaranteed (for linear motors or third-party motors, for example), use a Sensor Module External (SME120 or SME125) or Terminal Module TM120.

8.3.3.4 X524 Electronics power supply

Table 8- 11 X524: Electronics power supply

	Terminal	Function	Technical data
	+	Electronics power supply	Voltage: 24 V (20.4 ... 28.8 V) Current consumption: Max. 0.35 A Maximum current via jumper in connector: 20 A (15 A according to UL/CSA)
	+	Electronics power supply	
	M	Electronics ground	
	M	Electronics ground	
Type: Screw-type terminal (Page 263) Max. cross section that can be connected: 2.5 mm ²			

The maximum cable length that can be connected is 30 m.

Note

The two "+" or "M" terminals are jumpered in the connector. This ensures that the supply voltage is looped through.

8.3.4 Meaning of the LED

Table 8- 12 Meaning of the LED on the Sensor Module Cabinet-Mounted SMC20

LED	Color	Status	Description, cause	Remedy
RDY READY	-	Off	The electronics power supply is missing or outside the permissible tolerance range.	-
	Green	Continuous light	The component is ready for operation. Cyclic DRIVE-CLiQ communication is taking place.	-
	Orange	Continuous light	DRIVE-CLiQ communication is being established.	-
	Red	Continuous light	This component has at least one fault. Note: The LED is activated irrespective of whether the corresponding messages have been reconfigured.	Remove and acknowledge the fault.
	Green/red	0.5 Hz flashing light	Firmware is being downloaded.	-
		2 Hz flashing light	Firmware download is complete. The system waits for POWER ON.	Carry out a POWER ON.
	Green / Orange or Red / Orange	Flashing light	Component recognition via LED is activated ¹⁾ . Note: Both options depend on the LED status when component recognition is activated.	-

¹⁾ See SINAMICS S110 List Manual for the parameters to activate component recognition via LED

Cause and rectification of faults

The following documents contain information about the cause of faults and how they can be rectified:

- SINAMICS S110, Function Manual
- SINAMICS S110, List Manual

8.3.5 Dimension drawing

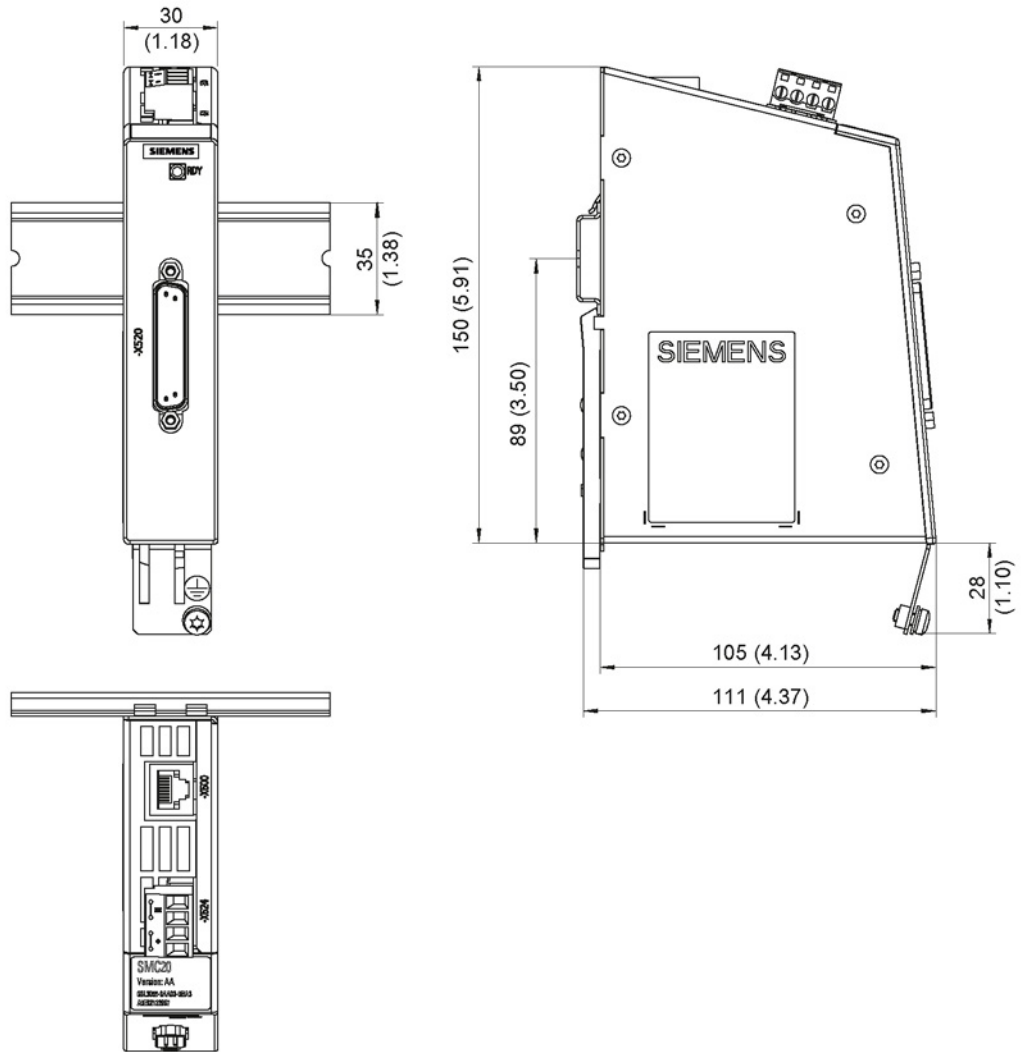

Figure 8-8 Dimension drawing of the Sensor Module Cabinet SMC20, all data in mm and (inches)

8.3.6 Mounting

Installation

1. Tilt the component backwards slightly and attach it to the DIN rail using the hooks.
2. Swivel the component onto the DIN rail until you hear the mounting slide at the rear latch into position.
3. Slide the components along the mounting rail to either the left or right up to their final position.

Removal

1. First shift the mounting slide downwards at the lug to release the interlocking with the mounting rail.
2. Swivel the component to the front and withdraw it upwards from the DIN rail.

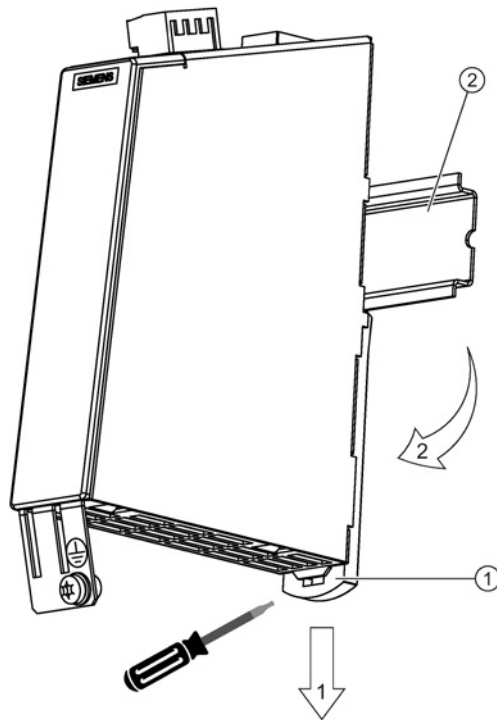

- ① Mounting slide
- ② Mounting rail

Figure 8-9 Removing from a DIN mounting rail

8.3.7 Technical data

Table 8- 13 Technical data

6SL3055-0AA00-5BAx	Unit	Value
Electronics power supply		
Voltage	V _{DC}	24 (20.4 ... 28.8)
Current (without encoder system)	A _{DC}	≤ 0.20
Current (with encoder system)	A _{DC}	≤ 0.35
Power loss	W	≤ 10
Max. Cable length	m	30
Encoder system power supply		
Voltage	V _{DC}	5 V DC (with remote sense) ¹⁾
Current	A _{DC}	0.35
Encoder frequency that can be evaluated (f _{en-coder})	kHz	≤ 500
SSI baud rate ²⁾	kBd	100 - 1000 ³⁾
Max. Encoder cable length	m	100
PE/ground connection		At the housing with M4/1.8 Nm screw
Weight	kg	0.45
Degree of protection		IP20 or IPXXB

- 1) A controller compares the encoder system supply voltage - sensed via the Remote Sense cables - with the reference supply voltage of the encoder system, and adjusts the supply voltage for the encoder system at the output of the sensor module until the required supply voltage is obtained directly at the encoder system (only for 5 V encoder system power supply).
- 2) Only possible for SSI encoders with 5 V supply.
- 3) See the diagram "Maximum cable length depending on the SSI baud rate for SSI encoders"

Note

Current controller clock cycle

For a current controller cycle clock of 31.25 μs, use an SMC20 with Article No. 6SL3055-0AA00-5BA3.

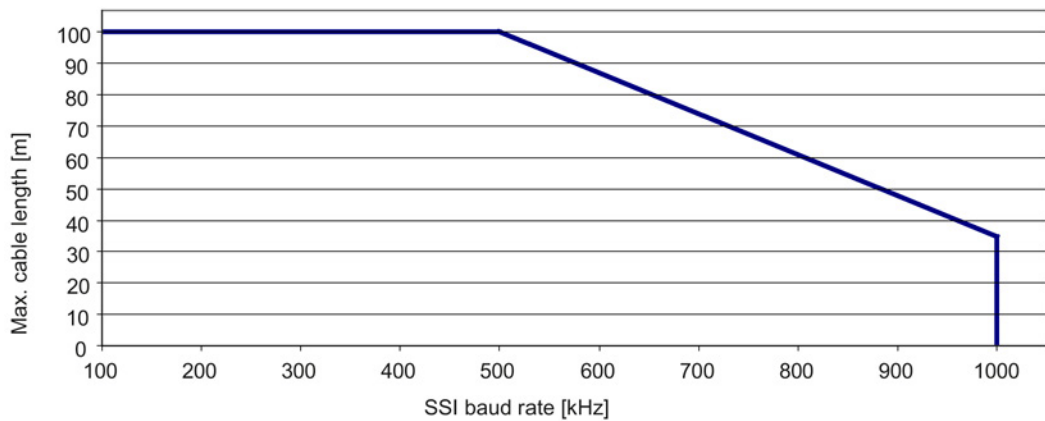

Figure 8-10 Maximum cable lengths depending on the SSI baud rate for SSI encoders

8.4 Sensor Module Cabinet-Mounted SMC30



8.4.1 Description

The Sensor Module Cabinet-Mounted SMC30 is an expansion module for snapping on to a standard mounting rail acc. to EN 60715. It evaluates encoder signals and transmits the speed, actual position, and, if applicable, the motor temperature and reference point via DRIVE-CLiQ to the Control Unit.

The SMC30 is used to evaluate encoder signals from encoders with TTL, HTL, or SSI interfaces.

A combination of TTL/HTL signal and SSI absolute signal is possible at terminals X521/X531, if both signals are derived from the same measured variable.

8.4.2 Safety instructions for Sensor Modules Cabinet-Mounted

 WARNING
Danger to life if the fundamental safety instructions and residual risks are not heeded Failure to heed the fundamental safety instructions and residual risks in Chapter 1 (Page 17) can result in accidents causing severe injuries or death. <ul style="list-style-type: none">• Follow the fundamental safety instructions.• Consider the residual risks on the risk assessment.
 WARNING
Danger to life due to failure to heed the specific safety instructions for Sensor Modules Failure to heed the Specific safety instructions for Sensor Modules (Page 170) can result in accidents causing severe injuries or death. <ul style="list-style-type: none">• Heed the Specific safety instructions for Sensor Modules.

8.4.3 Interface description

8.4.3.1 Overview

X500
DRIVE-CLiQ interface

X524
Electronics power supply

LEDs

X520
Encoder system interface
HTL, TTL with
Track monitoring,
SSI

Alternative encoder system
Interface
HTL, TTL with
Track monitoring,
SSI

Protective conductor connection
M4 / 1.8 Nm

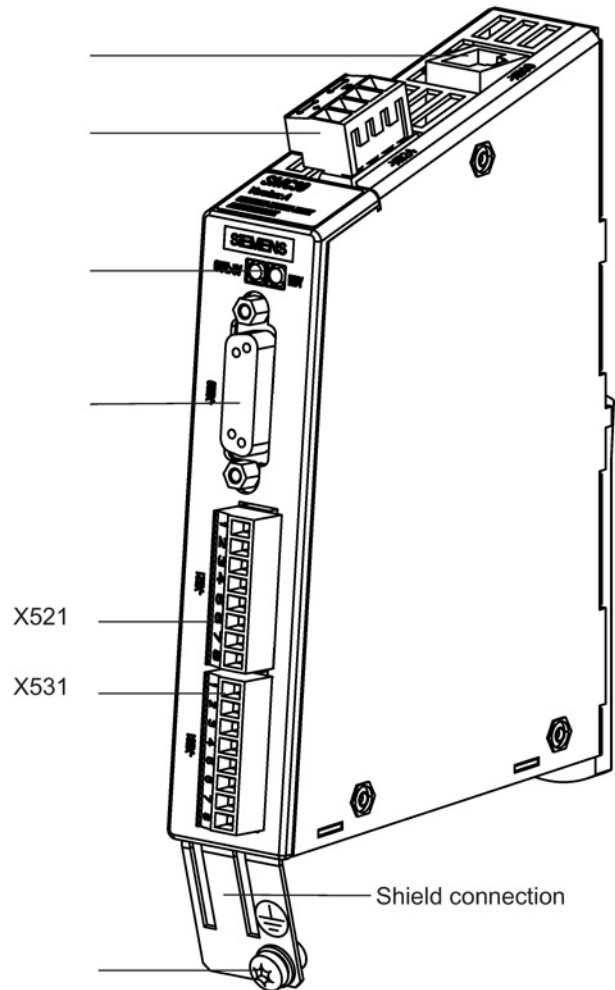
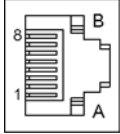

Figure 8-11 Interface description of the SMC30

8.4.3.2 X500 DRIVE-CLiQ interface

Table 8- 14 X500: DRIVE-CLiQ interface

	Pin	Signal name	Technical data
	1	TXP	Transmit data +
	2	TXN	Transmit data -
	3	RXP	Receive data +
	4	Reserved, do not use	
	5	Reserved, do not use	
	6	RXN	Receive data -
	7	Reserved, do not use	
	8	Reserved, do not use	
	A	Reserved, do not use	
	B	M (0 V)	Electronics ground
Connector type	DRIVE-CLiQ socket		

The blanking cover for the DRIVE-CLiQ port is included in the scope of delivery.

Blanking covers (50 x) Article No.: 6SL3066-4CA00-0AA0

8.4.3.3 X520 encoder system interface

Table 8- 15 X520: Encoder system interface

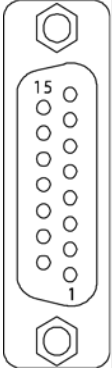
	Pin	Signal name	Technical data
	1	+Temp ¹⁾	Motor temperature sensing KTY84-1C130 (KTY+) Temperature sensor KTY84-1C130 / PTC
	2	Clock	SSI clock
	3	Clock*	Inverse SSI clock
	4	P encoder 5 V / 24 V	Encoder power supply
	5	P encoder 5 V / 24 V	
	6	P sense	Sense input of encoder power supply
	7	M encoder (M)	Ground for encoder power supply
	8	- Temp ¹⁾	Motor temperature sensing KTY84-1C130 (KTY-) Temperature sensor KTY84-1C130 / PTC
	9	M sense	Ground sense input
	10	R	Reference signal R
	11	R*	Inverse reference signal R
	12	B*	Inverse incremental signal B
	13	B	Incremental signal B
	14	A* / data*	Inverted incremental signal A/inverted SSI data
	15	A / data	Incremental signal A/SSI data
Connector type:	15-way Sub-D socket		
Measuring current via temperature sensor connection: 2 mA			

1) Accuracy of temperature measurement:

- KTY: ± 7 °C (incl. evaluation)
- PTC: ± 5 °C (incl. evaluation)

NOTICE

Damage to the encoder due to incorrect supply voltage

The encoder supply can be parameterized to 5 V or 24 V. Incorrect parameter assignment can cause damage to the encoder.

- Select the appropriate supply voltage.

NOTICE

Damage to motor due to incorrectly connected KTY temperature sensor

If a KTY temperature sensor is connected with incorrect polarity, it is not possible to detect when the motor overheats. Overheating can cause damage to the motor.

- Connect a KTY temperature sensor with the correct polarity.

Details on the parameterization of the KTY temperature sensor can be found in the SINAMICS S110 Function Manual.



 **WARNING**

Danger to life due to electric shock in the event of voltage flashovers on the temperature sensor cable

Voltage flashovers in the signal electronics can occur in motors without safe electrical separation of the temperature sensors.

- Only use temperature sensors that fully comply with the specifications of the safety isolation.
- If safe electrical separation cannot be guaranteed (for linear motors or third-party motors, for example), use a Sensor Module External (SME120 or SME125) or Terminal Module TM120.

8.4.3.4 X521 / X531 alternative encoder system interface

Table 8- 16 X521/X531: Alternative encoder system interface

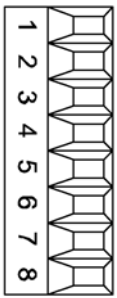
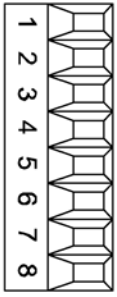
	Pin	Designation	Technical data
X521 	1	A	Incremental signal A
	2	A*	Inverse incremental signal A
	3	B	Incremental signal B
	4	B*	Inverse incremental signal B
	5	R	Reference signal R
	6	R*	Inverse reference signal R
	7	CTRL	Control signal
	8	M	Ground
X531 	1	P_Encoder 5 V / 24 V	Encoder power supply
	2	M_Encoder	Ground for encoder power supply
	3	-Temp ¹⁾	Motor temperature sensing KTY84-1C130 (KTY-) Temperature sensor KTY84-1C130 / PTC
	4	+Temp ¹⁾	Motor temperature sensing KTY84-1C130 (KTY+) Temperature sensor KTY84-1C130 / PTC
	5	Clock	SSI clock
	6	Clock*	Inverse SSI clock
	7	Data	SSI data
	8	Data*	Inverse SSI data
Max. cross section that can be connected: 1.5 mm ² Measuring current via the temperature sensor connection: 2 mA When unipolar HTL encoders are used, A*, B*, and R* on the terminal block must be jumpered with M_Encoder (X531) ²⁾ .			

1) Accuracy of temperature measurement:

- KTY: ± 7 °C (incl. evaluation)
- PTC: ± 5 °C (incl. evaluation)

2) Because the physical transmission media is more robust, the bipolar connection should always be used. The unipolar connection should only be used if the encoder type does not output push-pull signals.



! WARNING

Danger to life through electric shock due to unconnected cable shields

Hazardous touch voltages can occur through capacitive cross-coupling due to unconnected cable shields.

- Attach the cable shield to the component for the encoder system connection at the terminals.

Temperature sensor connection

NOTICE

Damage to motor due to incorrectly connected KTY temperature sensor

If a KTY temperature sensor is connected with incorrect polarity, it is not possible to detect when the motor overheats. Overheating can cause damage to the motor.

- Connect a KTY temperature sensor with the correct polarity.

Details on the parameterization of the KTY temperature sensor can be found in the SINAMICS S110 Function Manual.

Note

The maximum length of the temperature sensor cable is 100 m. The cables must be shielded.



! WARNING

Danger to life due to electric shock caused by sparkovers to the temperature sensor cable

Sparkovers in the signal electronics can occur in motors without safe electrical separation of the temperature sensors.

- Only use temperature sensors that fully comply with the specifications for safe separation.
- If safe electrical separation cannot be guaranteed (for linear motors or third-party motors, for example), use a Sensor Module External (SME120 or SME125) or a Terminal Module TM120.

8.4.3.5 X524 Electronics power supply

Table 8- 17 X524: Electronics power supply

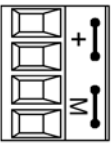
	Terminal	Function	Technical data
	+	Electronics power supply	Voltage: 24 V (20.4 ... 28.8 V) Current consumption: Max. 0.35 A Maximum current via jumper in connector: 20 A (15 A according to UL/CSA)
	+	Electronics power supply	
	M	Electronics ground	
	M	Electronics ground	
Type: Screw-type terminal (Page 263) Max. cross section that can be connected: 2.5 mm ²			

The maximum cable length that can be connected is 30 m.

Note

The two "+" or "M" terminals are jumpered in the connector. This ensures that the supply voltage is looped through.

8.4.4 Connection examples

Connection example 1: HTL encoder, bipolar, with reference signal

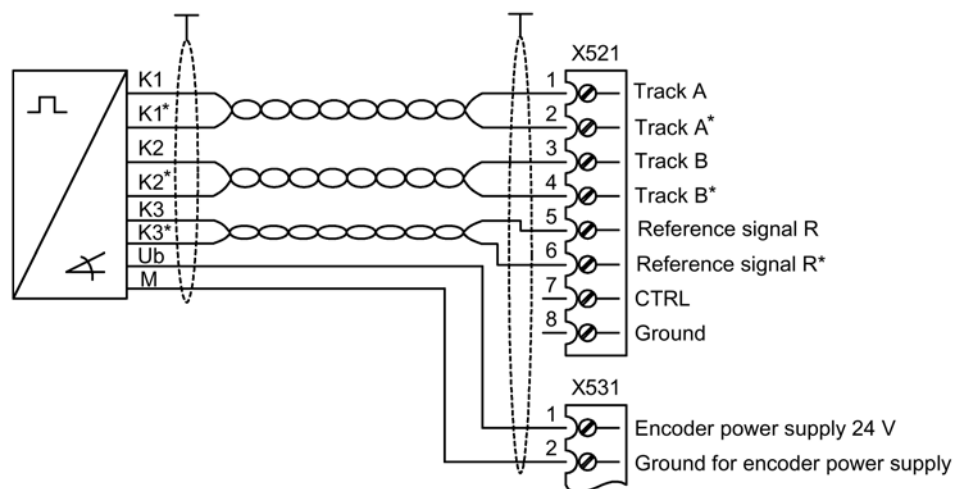

Figure 8-12 Connection example 1: HTL encoder, bipolar, with reference signal

Signal cables must be twisted in pairs to improve immunity to induced noise.

Connection example 2: HTL encoder, unipolar, with reference signal

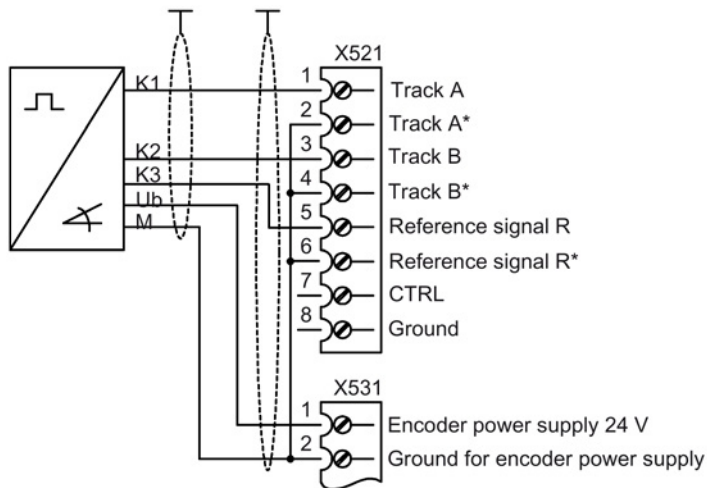

Figure 8-13 Connection example 2: HTL encoder, unipolar, with reference signal¹⁾

¹⁾ Because the physical transmission media is more robust, the bipolar connection should always be used. The unipolar connection should only be used if the encoder type does not output push-pull signals.

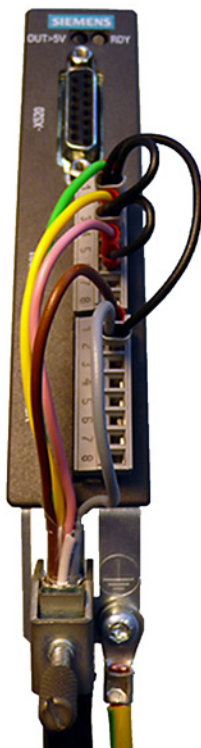

Figure 8-14 Photo of connection example 2: SMC30, 30 mm wide

The photo above shows the wire jumpers for connecting unipolar HTL encoders with a reference signal.

8.4.5 Meaning of LEDs

Table 8- 18 Meaning of LEDs on the Sensor Module Cabinet SMC30

LED	Color	Status	Description, cause	Remedy
RDY READY	–	Off	The electronics power supply is missing or outside the permissible tolerance range.	–
	Green	Continuous light	The component is ready for operation. Cyclic DRIVE-CLiQ communication is taking place.	–
	Orange	Continuous light	DRIVE-CLiQ communication is being established.	–
	Red	Continuous light	This component has at least one fault. Note: LED is controlled independently of any reconfiguration of the corresponding messages.	Remedy and acknowledge fault
	Green/red	Flashing light 0.5 Hz	Firmware is being downloaded.	–
	Green/red	Flashing light 2 Hz	Firmware download is complete. The system waits for POWER ON.	Carry out a POWER ON
	Green/orange or Red/orange	Flashing light	Component recognition via LED is activated ¹⁾ . Note: Both options depend on the LED status when component recognition is activated.	–
OUT > 5 V	–	Off	The electronic power supply is missing or outside permissible tolerance range. Power supply \leq 5 V.	–
	Orange	Continuous light	The electronics power supply for the encoder system is available. Power supply > 5 V	–

¹⁾ Data on the parameters for activating the component recognition via LED, see SINAMICS S110 List Manual

NOTICE
<p>Damage to the encoder electronics due to incorrect voltage supply</p> <p>If an encoder that is designed for a 5 V supply is operated with a 24 V supply, this can destroy the encoder electronics.</p> <ul style="list-style-type: none"> • Make sure that the connected encoder can be operated with a 24 V power supply.

Cause and rectification of faults

The following documents contain information about the cause of faults and how they can be rectified:

- SINAMICS S110, Function Manual
- SINAMICS S110, List Manual

8.4.6 Dimension drawing

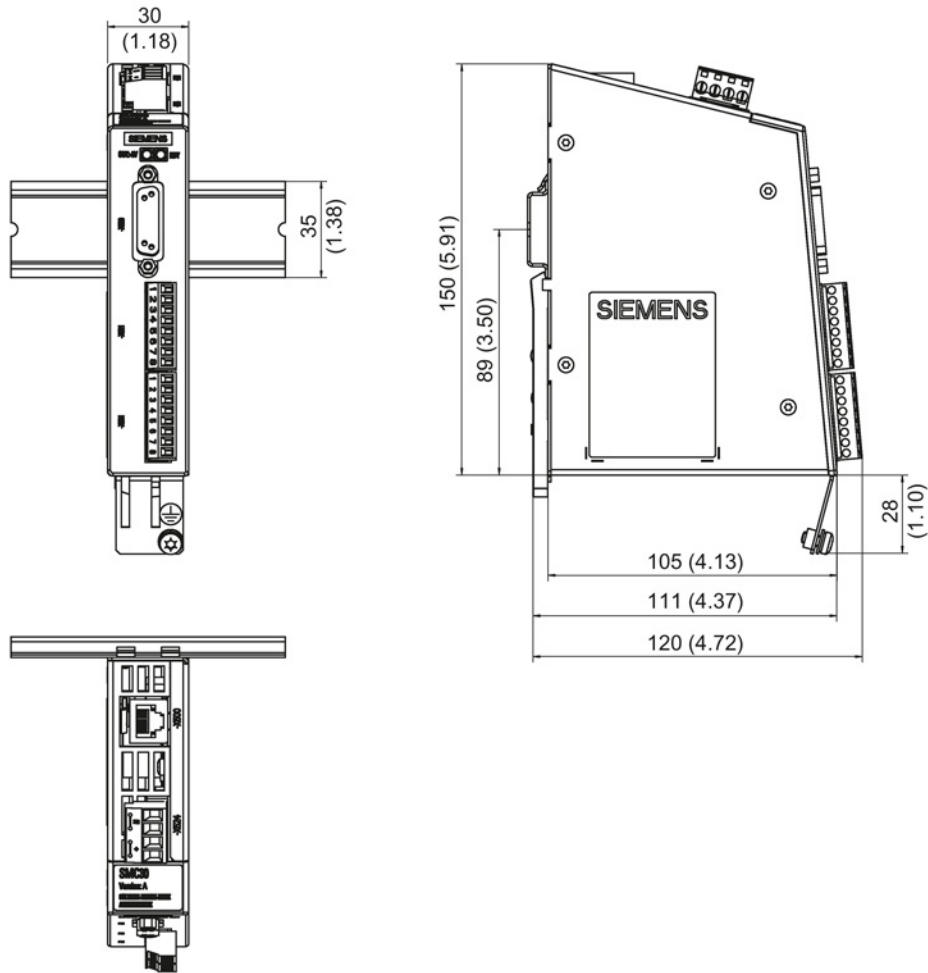

Figure 8-15 Dimension drawing of the Sensor Module Cabinet SMC30, all data in mm and (inches)

8.4.7 Mounting

Installation

1. Tilt the component backwards slightly and attach it to the DIN rail using the hooks.
2. Swivel the component onto the DIN rail until you hear the mounting slide at the rear latch into position.
3. Slide the components along the mounting rail to either the left or right up to their final position.

Removal

1. First shift the mounting slide downwards at the lug to release the interlocking with the mounting rail.
2. Swivel the component to the front and withdraw it upwards from the DIN rail.

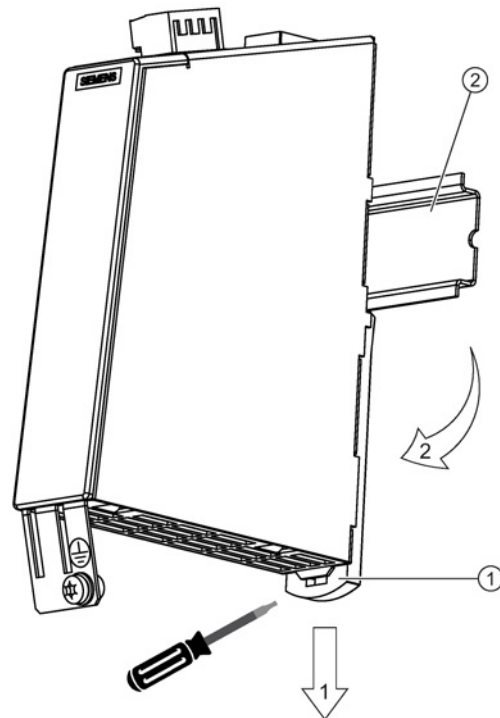

- ① Mounting slide
② Mounting rail

Figure 8-16 Removing from a DIN mounting rail

8.4.8 Protective conductor connection and shield support

Shield contacts are only required if the system is connected to X521/X531.

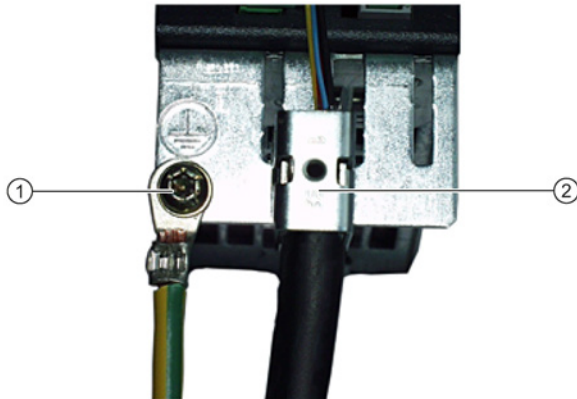

- ① PE conductor connection M4 / 1.8 Nm
- ② Shield connection terminal, Weidmüller company, type: KLBÜ CO1, Article No.: 1753311001

Figure 8-17 Shield support and PE conductor connection

The bending radii of the cables must be observed (see MOTION-CONNECT description).

NOTICE

Damage or faulty operation due to incorrect shielding or inadmissible cable lengths

If the correct shielding procedures or the permissible cable lengths are not observed, it can cause damage or the machine may malfunction.

- Only use shielded cables.
- Do not exceed the cable lengths stated in the technical data.

8.4.9 Technical data

Table 8- 19 Technical data

6SL3055-0AA00-5CA2	Unit	Value
Electronics power supply		
Voltage	V_{DC}	24 (20.4 ... 28.8)
Current (without encoder system)	A_{DC}	≤ 0.20
Current (with encoder system)	A_{DC}	≤ 0.55
Power loss	W	≤ 10
Encoder system power supply		
Voltage	V_{DC}	5 (with or without remote sense) ¹⁾ or $V_{DC} - 1 V$
Current	A_{DC}	0.35
Encoder frequency that can be evaluated ($f_{encoder}$)	kHz	≤ 300
SSI baud rate	kBd	100 - 1000 ²⁾
PE/ground connection		At the housing with M4/1.8 Nm screw
Weight		0.45
Degree of protection		IP20 or IPXXB

1) A controller compares the encoder system supply voltage - sensed via the Remote Sense cables - with the reference supply voltage of the encoder system, and adjusts the supply voltage for the encoder system at the output of the sensor module until the required supply voltage is obtained directly at the encoder system (only for 5 V encoder system power supply). Remote Sense only to X520.

2) See the diagram "Maximum cable length depending on the SSI baud rate for SSI encoders"

Encoder systems that can be connected

Table 8- 20 Specification of encoder systems that can be connected

Parameter	Designation	Threshold	Min.	Max.	Unit
High signal level (TTL bipolar at X520 or X521/X531) ¹⁾	U_{Hdiff}		2	5	V
Low signal level (TTL bipolar at X520 or X521/X531) ¹⁾	U_{Ldiff}		-5	-2	V
High signal level (HTL unipolar)	$U_H^{3)}$	High	17	V_{CC}	V
		Low	10	V_{CC}	V
Low signal level (HTL unipolar)	$U_L^{3)}$	High	0	7	V
		Low	0	2	V
High signal level (HTL bipolar) ²⁾	U_{Hdiff}		3	V_{CC}	V
Low signal level (HTL bipolar) ²⁾	U_{Ldiff}		$-V_{CC}$	-3	V
High signal level (SSI bipolar at X520 or X521/X531) ¹⁾	U_{Hdiff}		2	5	V
Low signal level (SSI bipolar at X520 or X521/X531) ¹⁾	U_{Ldiff}		-5	-2	V
Signal frequency	f_S		-	300	kHz
Edge clearance	t_{min}		100	-	ns

8.4 Sensor Module Cabinet-Mounted SMC30

Parameter	Designation	Threshold	Min.	Max.	Unit
"Zero pulse inactive time" (before and after A=B=high)	t _{Lo}		640	(t _{ALo-BHi} - t _{Hi})/2 ⁴⁾	ns
"Zero pulse active time" (while A=B=high and beyond)	t _{Hi}		640	t _{ALo-BHi} - 2*t _{Lo} ⁴⁾	ns

- 1) Other signal levels according to the RS 422 standard.
- 2) The absolute level of the individual signals varies between 0 V and V_{CC} of the encoder system.
- 3) Only with Article No. 6SL3055-0AA00-5CA2 and firmware version 2.5 SP1 or higher can this value be configured using software. For older firmware releases and Article Nos. less than 6SL3055-0AA00-5CA2, the "low" threshold applies.
- 4) t_{ALo-BHi} is not a specified value, but is the time between the falling edge of track A and the next but one rising edge of track B.

Table 8- 21 Encoders that can be connected

	X520 (SUB-D)	X521 (terminal)	X531 (terminal)	Track monitoring	Remote Sense ²⁾
HTL bipolar 24 V	Yes	Yes		Yes	no
HTL unipolar 24 V ¹⁾	Yes	Yes (however, a bipolar connection is recommended) ¹⁾		no	no
TTL bipolar 24 V	Yes	Yes		Yes	no
TTL bipolar 5 V	Yes	Yes		Yes	At X520
SSI 24 V/5 V	Yes	Yes		no	no
TTL unipolar	no				

- 1) Because the physical transmission media is more robust, the bipolar connection should always be used. The unipolar connection should only be used if the encoder type does not output push-pull signals.
- 2) A controller compares the encoder system supply voltage - sensed via the Remote Sense cables - with the reference supply voltage of the encoder system, and adjusts the supply voltage for the encoder system at the output of the sensor module until the required supply voltage is obtained directly at the encoder system (only for 5 V encoder system power supply).

Maximum encoder cable lengths

Table 8- 22 Maximum encoder cable length

Encoder type	Maximum encoder cable length in m
TTL ¹⁾	100
HTL unipolar ²⁾	100
HTL bipolar	300
SSI	100 ³⁾

- 1) For TTL encoders at X520 → remote sense → 100 m
- 2) Because the physical transmission media is more robust, the bipolar connection should always be used. The unipolar connection should only be used if the encoder type does not output push-pull signals.
- 3) See the diagram "Maximum cable length depending on the SSI baud rate for SSI encoders"

SSI encoder

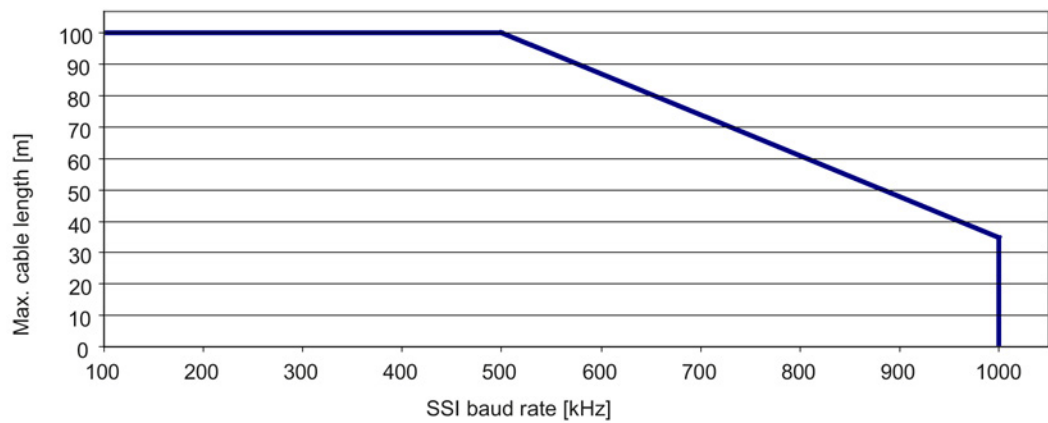

Figure 8-18 Maximum cable lengths depending on the SSI baud rate for SSI encoders

Encoders with 5 V supply connected to X521/X531

For encoders with a 5 V supply at X521/X531, the cable length depends on the encoder current (for 0.5 mm² conductor cross sections):

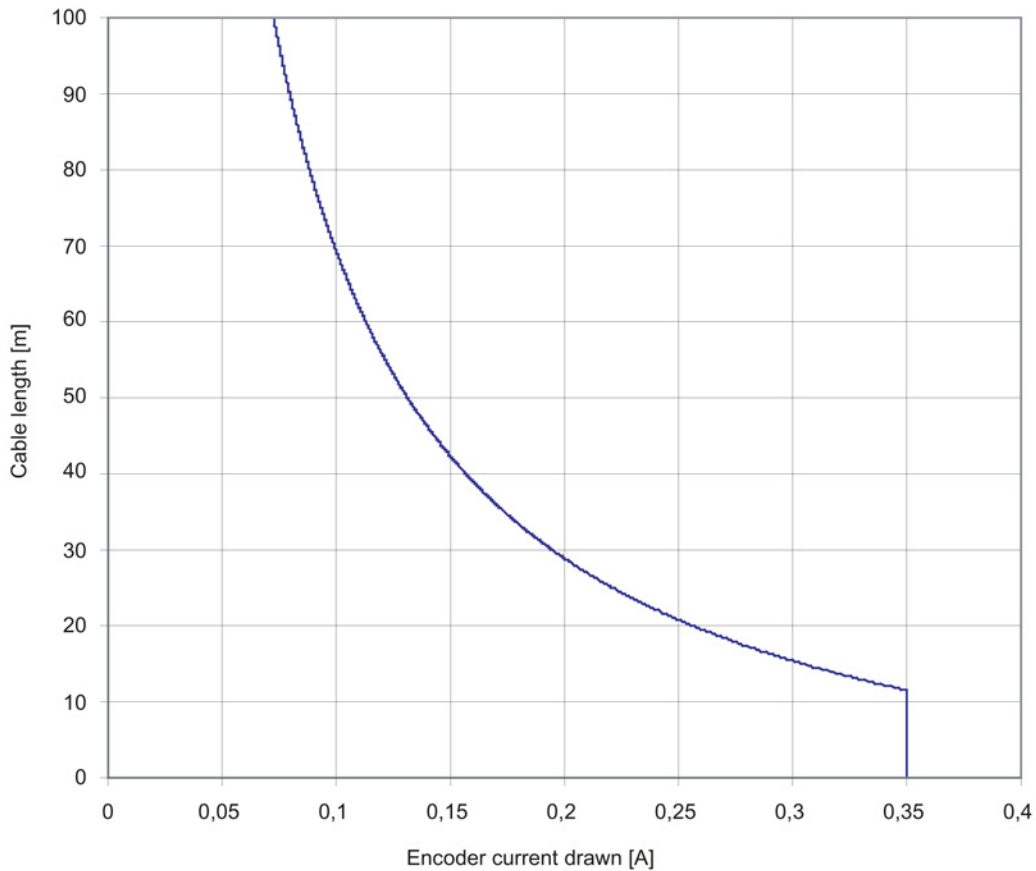

Figure 8-19 Max. cable length as a function of the encoder current drawn

Encoders without remote sense

When encoders without Remote Sense are used, the permissible cable length is limited to 100 m max. because the voltage drop depends on the cable length and the encoder current.

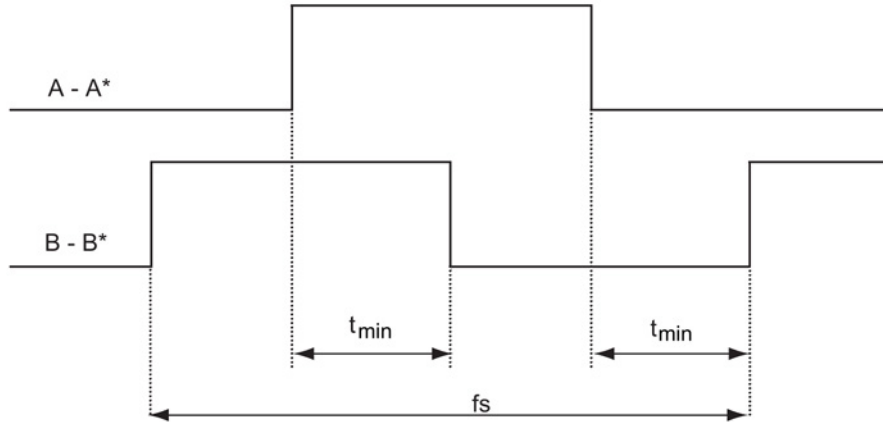

Figure 8-20 Signal characteristic of track A and track B between two edges: Time between two edges with pulse encoders

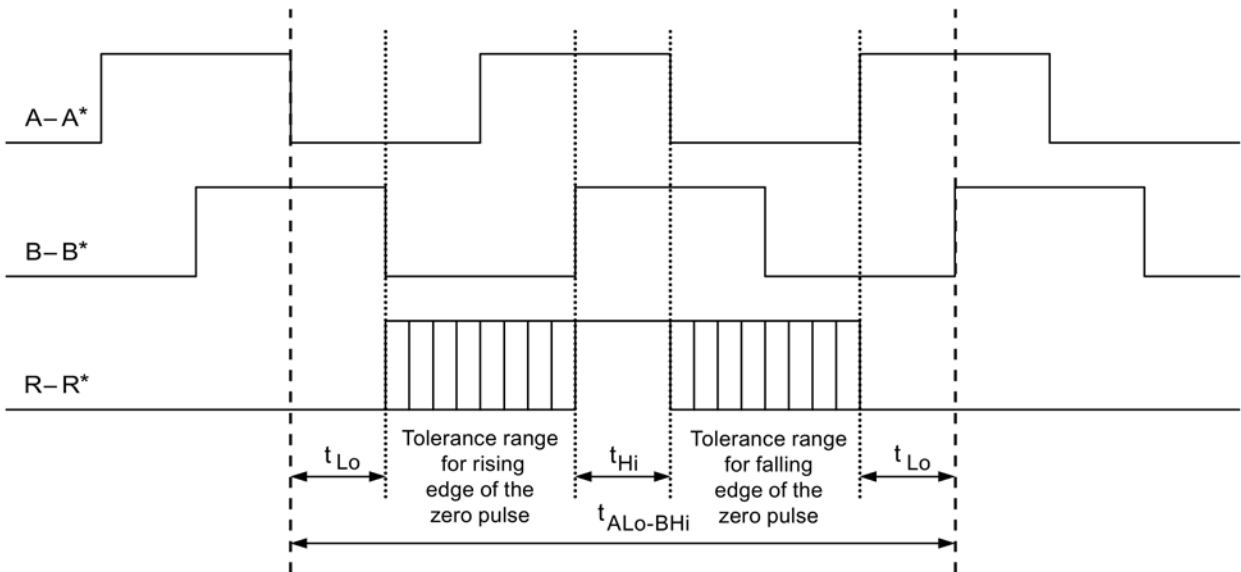

Figure 8-21 Position of the zero pulse to the track signals

8.5 Option module Safe Brake Relay

8.5.1 Description

A Safe Brake Relay is required for operating motors with holding brakes up to 2 A.

The Safe Brake Relay is the interface between the Control Unit / Blocksize Power Modules, and the 24 VDC motor brake.

The motor brake is electronically controlled.

The supply voltage for the motor brake must be separately connected to the Safe Brake Relay. A regulated power supply is required, whose rated value (to compensate for the voltage drop in the supply cable for the 24 VDC motor brake coil) can be set to 26 V, e.g. SITOP modular.

Table 8- 23 Interface overview the Safe Brake Relay

Type	Number
Connection for the solenoid of the motor brake	1
Connection for a 24 VDC power supply	1
Connection for the pre-fabricated (CTRL) to the Power Module, Blocksize format	1

The Safe Brake Relay is supplied with the pre-fabricated cable to connect to the Power Module and all of the customer connectors.

8.5.2 Safety instructions for Safe Brake Relays

Note

A regulated DC power supply is required to operate motors with a built-in holding brake. The voltage is supplied via the internal 24 V busbars. The voltage tolerances of the motor holding brakes and the voltage losses of the connection cables must be observed.

- Set the DC power supply to 26 V. This ensures that the power supply for the brake remains within the permissible range when the following conditions are met:
 - Use of Siemens three-phase motors
 - Use of Siemens MOTION-CONNECT power cables
 - Motor cable lengths: max. 100 m
-

8.5.3 Interface description

8.5.3.1 Overview

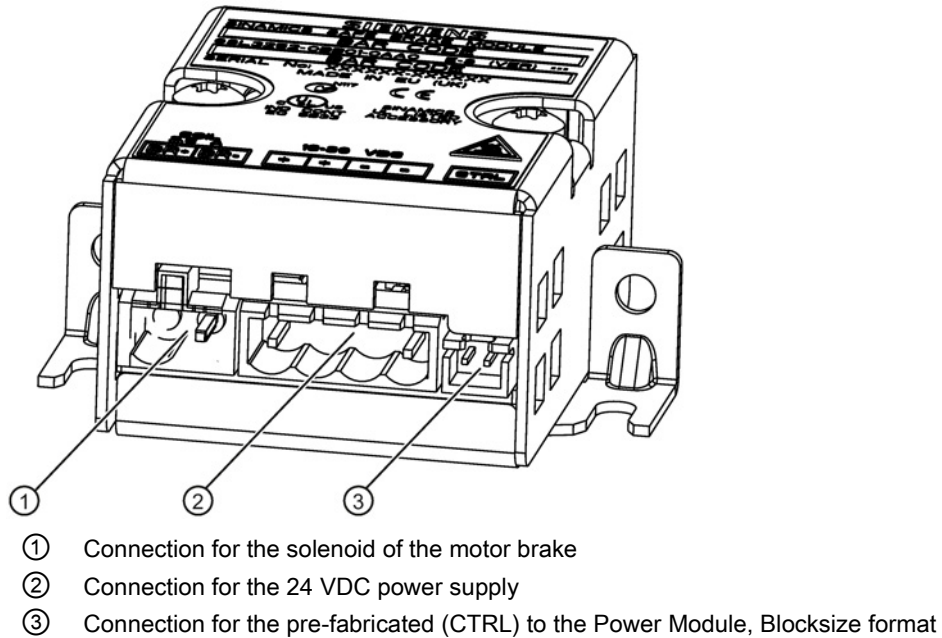

Figure 8-22 Interface description: Safe Brake Relay

8.5.3.2 X524 electronics power supply

Table 8- 24 X524: Electronics power supply

	Terminal	Function	Technical data
	+	Electronics power supply	Voltage: 24 V (20.4 ... 28.8 V)
	+	Electronics power supply	
	M	Electronics ground	Max. current via jumper in connector: 20 A (15 A according to UL/CSA)
	M	Electronics ground	
Type: Screw-type terminal (Page 263) Max. cross section that can be connected: 2.5 mm ²			

The maximum cable length that can be connected is 30 m.

Note

The two "+" or "M" terminals are jumpered in the connector. This ensures that the supply voltage is looped through.

8.5.3.3 Brake connection

Table 8- 25 Connector

Designation	Technical specifications
Brake connection	Relay output (close)
PE connection	M4 / 3 Nm

8.5.4 Connection example

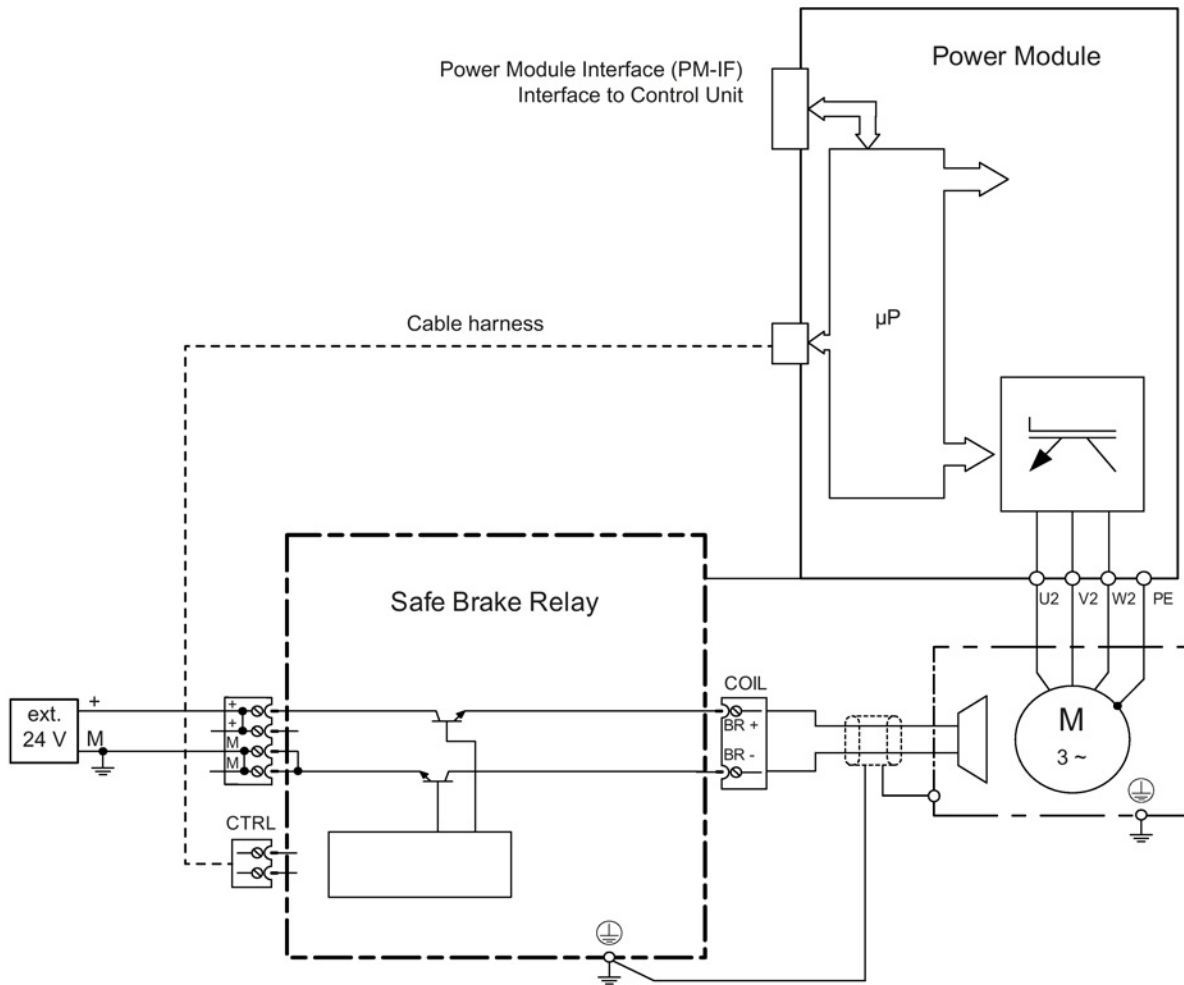

Figure 8-23 Safe Brake Relay connection example

8.5.5 Dimension drawing

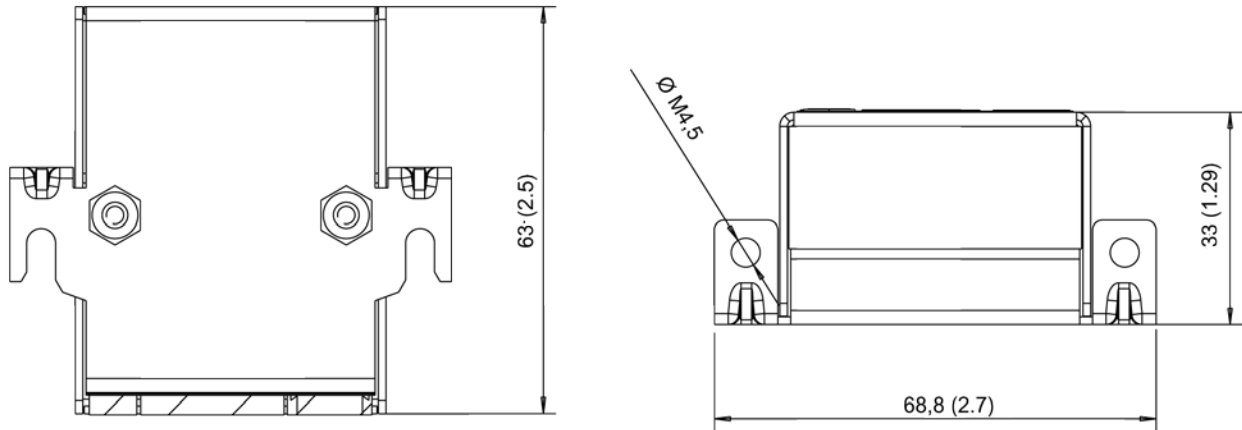

Figure 8-24 Dimension drawing of Safe Brake Relay, all data in mm and (inches)

8.5.6 Mounting

The Safe Brake Relay is installed at the rear of the cabinet next to the Power Module.

8.5.7 Technical data

Table 8- 26 Technical data

6SL3252-0BB01-0AA0	Unit	
Power supply	V _{DC}	20.4 ... 28.8 Recommended nominal value of the power supply 26 V DC (to equalize and compensate for the voltage drop along the feeder cable to the 24 V DC solenoid of the motor brake)
Current requirement, max.		
Motor brake at 24 V DC	A	2
	A	0.05 + current requirement of the motor brake
Conductor cross section, max.	mm ²	2.5
Dimensions (W x H x D)	mm	69 x 63 x 33
Weight	kg	approx. 0.17

Accessories

9.1 DRIVE-CLiQ cabinet bushing

9.1.1 Description

A DRIVE-CLiQ cabinet bushing is used to connect the DRIVE-CLiQ cables between the inside and outside of the control cabinet. It is used in a control cabinet panel. The data lines and the voltage supply contacts of the DRIVE-CLiQ are also routed through the bushing. The DRIVE-CLiQ cabinet bushing for DRIVE-CLiQ cables is available with DRIVE-CLiQ connector and M12 connector/socket.

DRIVE-CLiQ cabinet bushing for DRIVE-CLiQ connectors

The cabinet bushing has degree of protection IP54 according to EN 60529 from the outside towards the inside. Inside the control cabinet, a connection is established according to degree of protection IP20 or IPXXB acc. to EN 60529. So that the complete outside of the cabinet bushing, including the DRIVE-CLiQ interface, has degree of protection IP54, a DRIVE-CLiQ cable must be used, which as a minimum must also have degree of protection IP54.

DRIVE-CLiQ cabinet bushing for M12 plug/socket

The cabinet bushing has degree of protection IP67 according to EN 60529 from the outside towards the inside. Inside the cabinet a connection according to degree of protection IP67 in compliance with EN 60529 is realized.

9.1.2 Safety Information

NOTICE

Damage caused by the use of incorrect DRIVE-CLiQ cables

The use of incorrect or not released DRIVE-CLiQ cables can cause damage or functional faults to devices or the system.

- Use only appropriate DRIVE-CLiQ cables that have been approved by Siemens for the use case in question.

9.1.3 Interface description

9.1.3.1 Overview

DRIVE-CLiQ cabinet bushing for DRIVE-CLiQ cables with DRIVE-CLiQ connectors

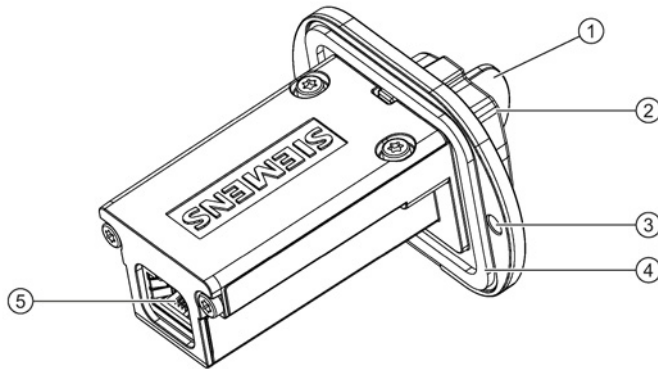

- ① Protective cap, Yamaichi, Article No.: Y-ConAS-24-S
- ② DRIVE-CLiQ interface on the outside (to connect DRIVE-CLiQ signal cables MOTION-CONNECT with IP67 degree of protection)
- ③ Mounting holes
- ④ Flange-type seal to ensure degree of protection IP54 on the outside of the cabinet
- ⑤ DRIVE-CLiQ interface on the inside (to connect DRIVE-CLiQ signal cables MOTION-CONNECT with IP20 degree of protection)

Figure 9-1 Interface overview, DRIVE-CLiQ cabinet bushing

DRIVE-CLiQ cabinet bushing for DRIVE-CLiQ cables with M12 plug/socket

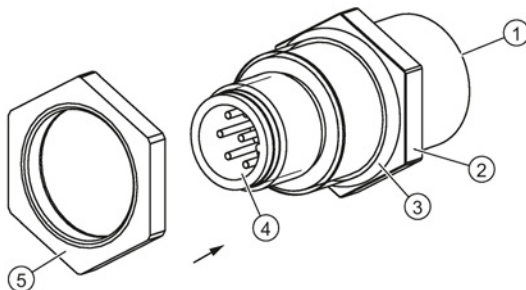

- ① DRIVE-CLiQ interface with M12 socket (8-pin)
- ② Flange, SW18
- ③ Seal
- ④ DRIVE-CLiQ interface with M12 plug (8-pin)
- ⑤ O ring, SW20, tightening torque: 3-4 Nm

Figure 9-2 Interface overview, DRIVE-CLiQ cabinet bushing M12

9.1.5 Mounting

9.1.5.1 DRIVE-CLiQ cabinet bushing for cables with RJ45 connectors

In order to install the DRIVE-CLiQ cabinet gland, you must make a cutout in the control cabinet panel as shown in the diagram below.

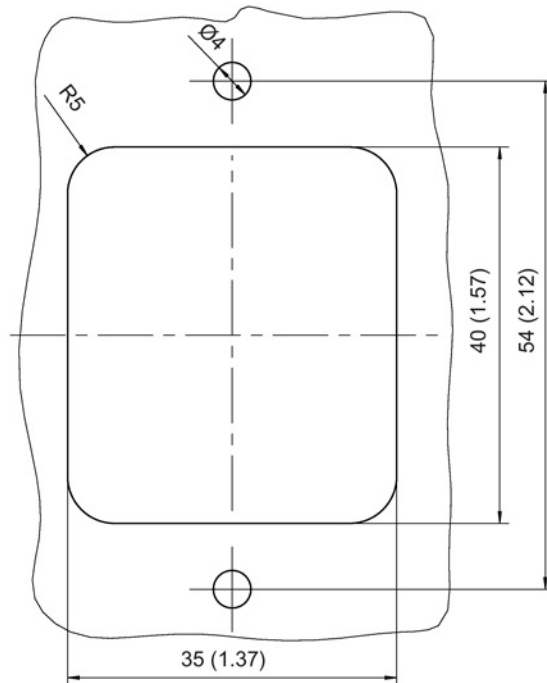
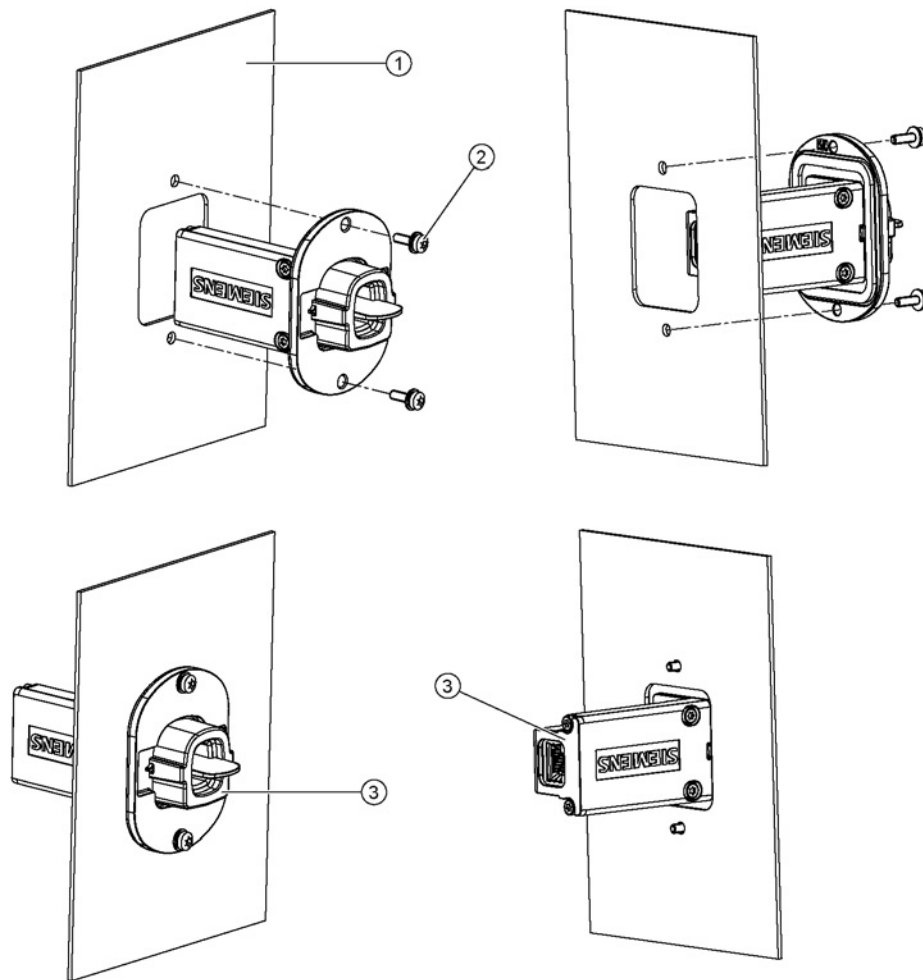

Figure 9-5 Cutout in the control cabinet, all dimensions in mm and (inches)

Installation

1. Insert the DRIVE CLiQ cabinet bushing from the outside of the control cabinet through the cutout in the control cabinet.
2. Attach the DRIVE-CLiQ cabinet bushing to the outer control cabinet panel using 2 M3 screws and 2 nuts. In order to ensure good electromagnetic compatibility, a good electrical connection must be established between the DRIVE-CLiQ cabinet gland and the cabinet panel over a large surface area.



- ① Control cabinet panel
- ② M3 screw, tightening torque 0.8 Nm
- ③ DRIVE-CLiQ cabinet bushing

Figure 9-6 Installing the DRIVE-CLiQ cabinet bushing for cables with DRIVE-CLiQ connectors

9.1.5.2 DRIVE-CLiQ cabinet bushing for cables with M12 plug/socket

Prepare the cabinet panel for mounting the DRIVE-CLiQ cabinet bushing M12 as shown below. The removable O ring can be screwed from the inside or the outside.

Mounting from the inside using an O ring that can be screwed

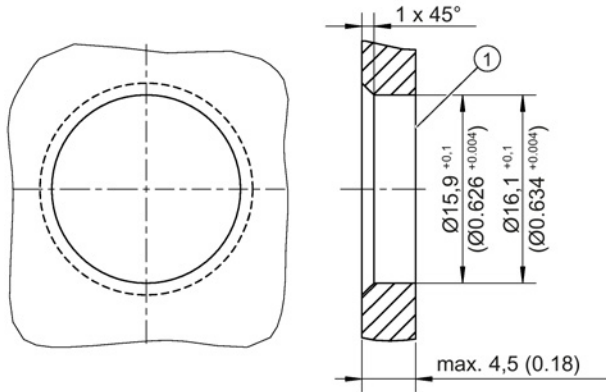

① Through-hole with chamfer

Figure 9-7 Through-hole for mounting the DRIVE-CLiQ cabinet bushing M12 with an O-ring that can be screwed from the inside

Mounting from the outside using an O ring that can be screwed

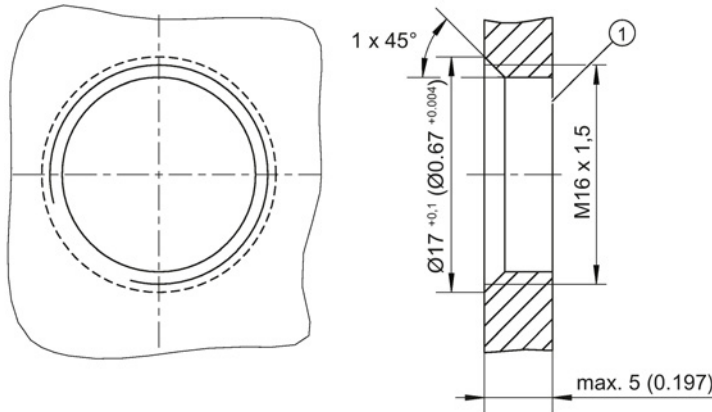

① Threaded hole with chamfer

Figure 9-8 Threaded hole for mounting the DRIVE-CLiQ cabinet bushing M12 with an O-ring that can be screwed from the outside

Mounting

1. Insert the DRIVE-CLiQ cabinet bushing through the opening in the cabinet.
2. Fasten the DRIVE-CLiQ cabinet bushing using the associated O ring with a tightening torque of 3-4 Nm

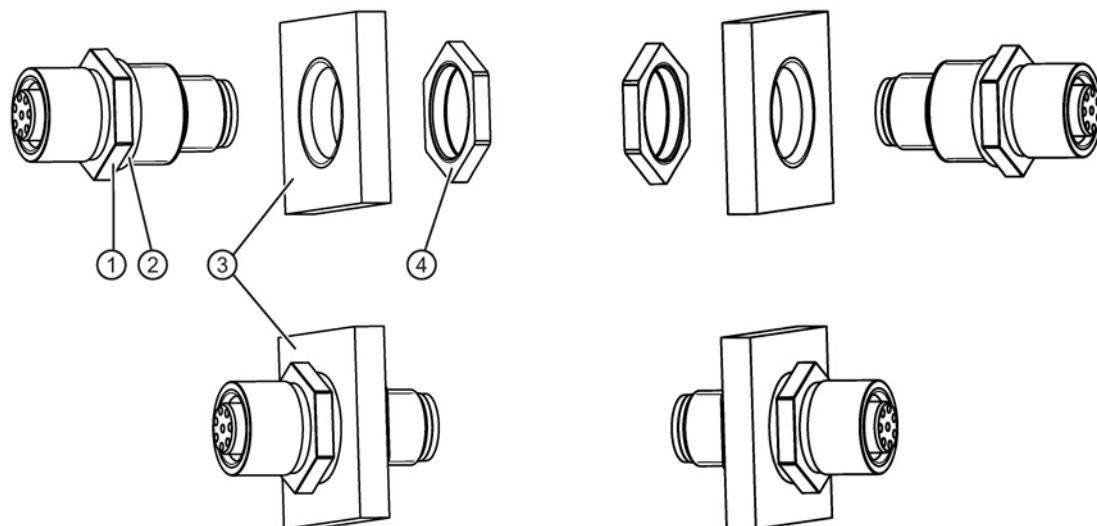

- ① Flange, SW18
- ② Seal
- ③ Cabinet panel
- ④ O ring, SW20, tightening torque: 3-4 Nm

Figure 9-9 Mounting DRIVE-CLiQ cabinet bushings for cables with M12 connectors

9.1.6 Technical data

Table 9- 1 Technical data of DRIVE-CLiQ cabinet bushings

	Unit	6SL3066-2DA00-0AA0 DRIVE-CLiQ	6FX2003-0DT67 M12
Weight	kg	0.165	0.035
Degree of protection according to EN 60529		IP54 outside the control cabinet IP20 or IPXXB inside the control cabinet	IP67

9.2 DRIVE-CLiQ coupling

9.2.1 Description

The DRIVE-CLiQ coupling is used to connect 2 DRIVE-CLiQ cables in accordance with degree of protection IP67 acc. to EN 60529.

In addition to the data lines, the power supply contacts of DRIVE-CLiQ are also routed via the coupling.

9.2.2 Safety Information

NOTICE

Damage caused by the use of incorrect DRIVE-CLiQ cables

The use of incorrect or not released DRIVE-CLiQ cables can cause damage or functional faults to devices or the system.

- Use only appropriate DRIVE-CLiQ cables that have been approved by Siemens for the use case in question.

9.2.3 Interface description

9.2.3.1 Overview

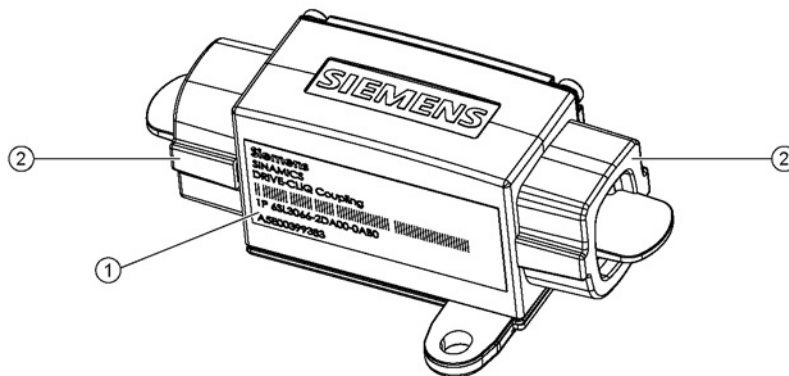

- ① Rating plate
- ② Protective cap, Yamaichi, Article No.: Y-ConAS-24-S

Figure 9-10 Interface overview, DRIVE-CLiQ coupling

9.2.4 Dimension drawing

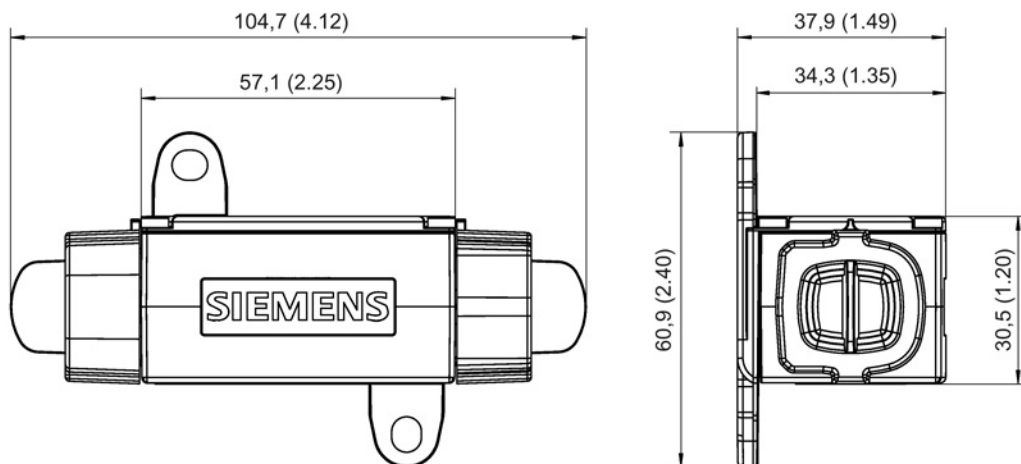
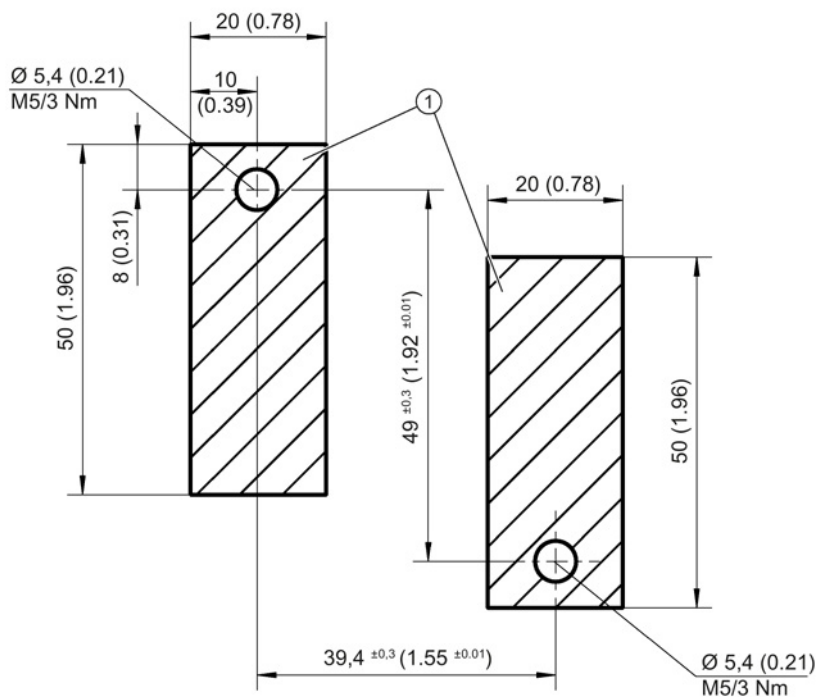

Figure 9-11 Dimension drawing of the DRIVE-CLiQ coupling, all dimensions in mm and (inches)

9.2.5 Mounting



① Contact surface

Figure 9-12 Hole drilling pattern for installation

Installation

1. Attach the DRIVE-CLiQ coupling to the mounting surface as shown in the drilling pattern.
2. Remove the protective caps of the DRIVE-CLiQ coupling.
3. Latch the DRIVE-CLiQ connectors at both sides of the DRIVE-CLiQ coupling.

9.2.6 Technical data

Table 9- 2 Technical data

DRIVE-CLiQ coupling 6SL3066-2DA00-0AB0	Unit	
Weight	kg	0,272
Degree of protection	IP67 acc. to EN 60529	

9.3 Mounting frame

9.3.1 Description

With the use and proper installation of Siemens mounting frames, the Power Modules Push Through achieve degree of protection IP55.

Article Nos.

- FSA: 6SL3260-6AA00-0DA0
- FSB: 6SL3260-6AB00-0DA0
- FSC: 6SL3260-6AC00-0DA0

The accessories package contains all the necessary nuts and seals.

9.3.2 Dimension drawings

Dimension drawings of mounting frame, frame sizes FSA to FSC

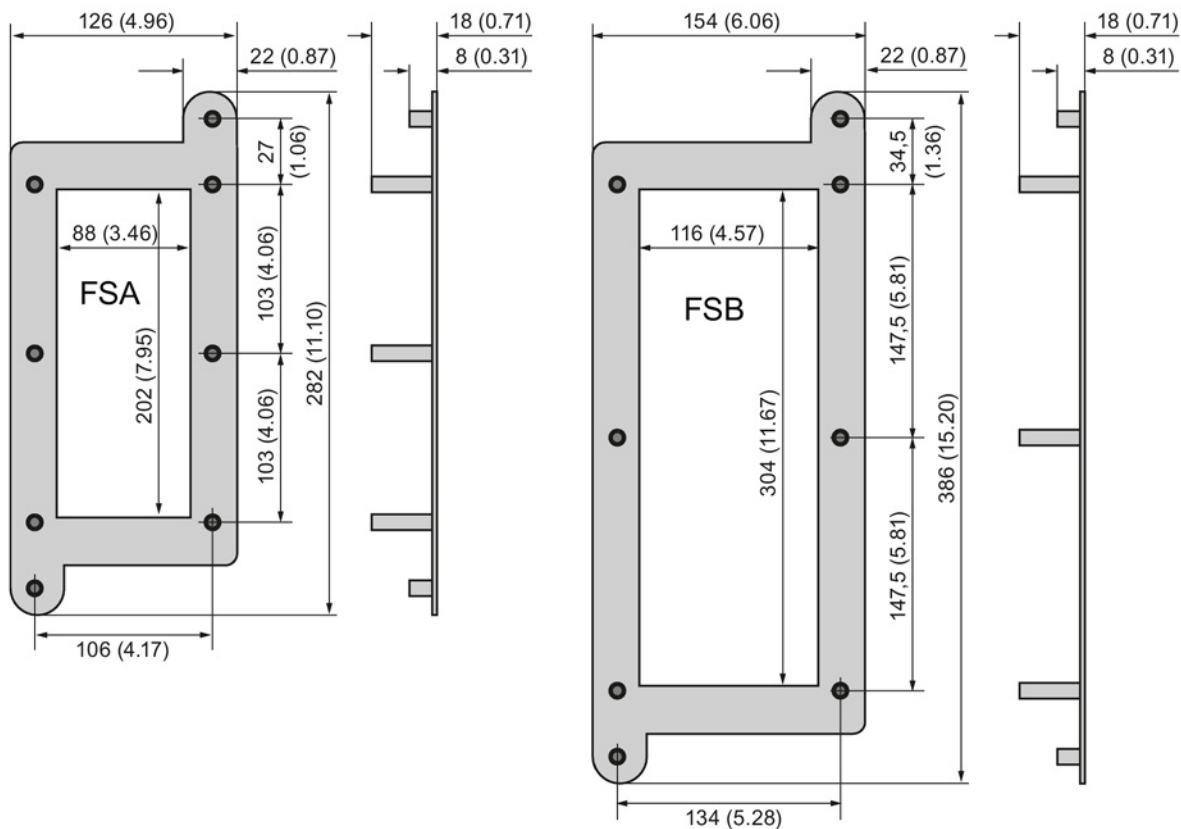

Figure 9-13 Dimension drawing of mounting frame, frame size FSA and FSB, all data in mm and (inches)

9.3 Mounting frame

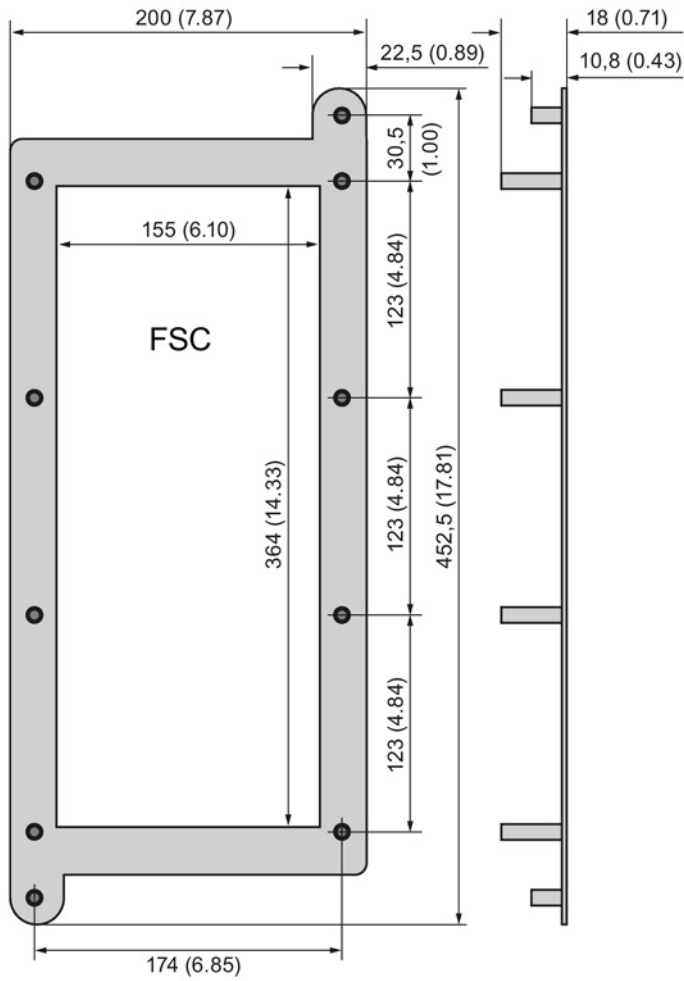

Figure 9-14 Dimension drawing of mounting frame, frame size FSC, all data in mm and (inches)

9.3.3 Mounting

Note**Compliance with the EMC requirements**

To meet the EMC requirements, make sure the contact surface of the heat sink is free of any paint.

Installation steps

1. Make an installation cutout and drill holes for the Power Module and the mounting frame according to the drilling pattern.
2. Fasten the mounting frame to the outer wall of the cabinet. Tighten the 2 screws finger-tight.
3. Attach the seal to the inner side of the cabinet.
4. Fasten the Power Module. Tighten the screws finger-tight.
5. Tighten all screws with a torque of 3.5 Nm.

10.1 General information

The SINAMICS S components are designed in accordance with degree of protection IPXXB according to EN 60529 and as open-type devices according to UL 50. This ensures protection against electric shock.

To also ensure protection against mechanical stress and climatic conditions, the components should only be operated in housing, cabinets or enclosed electrical operating areas that fulfill at least degree of protection IP54 and, as enclosure type 12, are designed according to UL 50.

Prefabricated MOTION-CONNECT cables are recommended.

Note

Functional safety of SINAMICS components

The components must be protected against conductive pollution, e.g. by installing them in a cabinet with degree of protection IP54 according to EN 60529. Provided conductive pollution can be prevented at the installation site, the degree of protection for the cabinet can be decreased accordingly.

Installation in a cabinet with degree of protection IP54 according to EN 60529 is advisable to ensure the safety functions of Safety Integrated are not compromised.

Low-voltage switchgear and controlgear assemblies

Part 1: Type-tested and partially type-tested low-voltage switchgear and controlgear assemblies

If the SINAMICS S drive line-up is used for the electrical equipment of machines, the applicable requirements of EN 60204-1 must also be adhered to.

Safety of machinery

Electrical equipment of machines

Part 1: General requirements

All information for device selection in this section applies to:

- Operation in a TN system
- Operating voltage range from 1-phase 200 VAC to 3-phase 440 VAC

10.2 Safety instructions for control panel manufacturing

 **WARNING**

Danger to life if the fundamental safety instructions and residual risks are not heeded

Failure to heed the fundamental safety instructions and residual risks in Chapter 1 can result in accidents causing severe injuries or death.

- Follow the fundamental safety instructions.
- Consider the residual risks on the risk assessment.



 **WARNING**

Danger to life caused by high leakage currents when the external PE conductor is interrupted

Drive components conduct high leakage currents through the PE conductor. When the PE conductor is interrupted, touching live components can result in electric shock, which can lead to death or serious injuries.

- Ensure that the external PE conductor complies with at least one of the following conditions:
 - It is laid protected against mechanical damage.¹⁾
 - If it consists of a single conductor, it has a cross section of at least 6 mm² Cu.
 - As a core of a multi-core cable, it has a cross section of at least 2.5 mm² Cu.
 - It has a parallel, second PE conductor with the same cross section.
 - It complies with the local regulations for equipment with increased leakage current.
- ¹⁾ Cables routed in control cabinets or enclosed machine enclosures are considered to be adequately protected against mechanical damage.



 **WARNING**

Danger to life as a result of electric shock for incorrectly routed brake cables

When routing brake cables without safe electrical separation, the insulation can fail resulting in electric shock.

- Connect the holding brake using the MOTION-CONNECT cable intended for the purpose.
- Only use third-party cables that have brake cores with safe electrical separation or separately route the brake cores with safe electrical separation.

 **WARNING**

Fire hazard due to overheating when permissible cable lengths are exceeded

Excessively long power cables can cause overheating of components with resulting fire and smoke development.

- The cable lengths (e.g. motor cable, DC-link cable) listed in the technical data must not be exceeded.

 WARNING
Danger of injury caused by foreign objects in the device Parts (e.g. drilling chips, end sleeves) falling into the device can cause short-circuits and damage the insulation. This can lead to serious injuries (arcing, bang, pieces flying out of the equipment). <ul style="list-style-type: none">• Only perform installation and other work when the devices are current-free.• Cover the ventilation slits during the installation of the cabinet and remove the cover before switching on.

NOTICE
Damage due to use of incorrect coupling or cabinet bushings on DRIVE-CLiQ connections Damage or malfunctions can occur on the devices or system if incorrect or unreleased couplings or cabinet bushings on DRIVE-CLiQ connections are used. <ul style="list-style-type: none">• Only use the DRIVE-CLiQ couplings and DRIVE-CLiQ cabinet bushings described in Chapter Accessories (Page 213).

10.3 Information on electromagnetic compatibility (EMC)

Requirements to implement EMC are listed in EN 61000-6-2, EN 61000-6-4, EN 61800-3, EN 60204-1 and in the "EMC installation guideline" Configuration Manual (Article No. 6FC5297-0AD30-0xPx). Conformance with the EMC Directive of the EC can be ensured by following the measures described in the "EMC installation guideline" Configuration Manual. When mounting components in cabinets, in order to fulfill the EMC Directive, the following conditions must be additionally observed:

- Connected to TN or TT line supply systems with grounded neutral point
- SINAMICS line filter
- Observance of information about cable shielding and equipotential bonding
- Only the recommended Siemens power and signal cables are used
- Only cables from Siemens may be used for DRIVE-CLiQ connections

You will find MOTION-CONNECT cables in catalog PM21.

10.4 Cable shielding and routing

In particular for meeting the requirements of EMC, certain cables must be routed with sufficient spacing and certain components must be mounted with a suitable clearance. To full EMC requirements, the following cables must be used with shields:

- Power supply cables from line filter via line reactor to Power Module
- All motor cables (if necessary, including cables for motor holding brake)
- Cables for "fast inputs" of the Control Unit
- Cables for analog direct voltage/current signals
- Signal cables for encoders
- Cables for temperature sensors

Alternative measures (e.g. routing behind mounting plates, suitable clearances) can also be used provided they have similar results. This excludes measures that relate to the design, installation, and routing of motor power cables and signal cables. If unshielded cables are used between the line supply connection point and the line filter, make sure that no interfering cable is routed in parallel.

The cable shields must be connected as close to the conductor terminal connections as possible to ensure a low-impedance connection with cabinet ground.

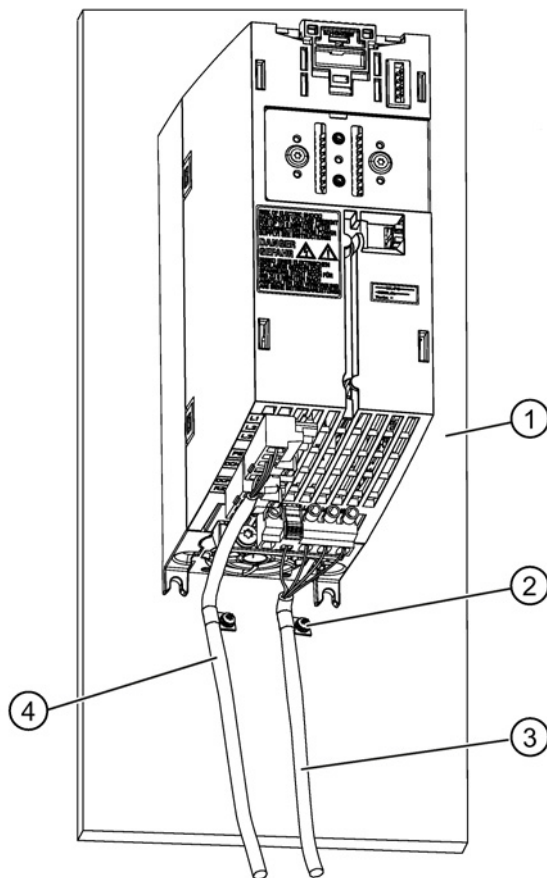

- ① Rear metal panel
- ② Clip to secure the shield of the motor and line cable to the rear metal panel
- ③ Motor cable (shielded)
- ④ Line supply input (shielded)

Figure 10-1 Shielding of a PM240-2 Power Module, frame size FSA

Alternatively, the cable shields can be connected to them metal mounting plate using pipe clamps and serrated rails. The cable length between the shield connection point and the wire terminals must be kept as short as possible.

Shield connection plates and shield connection kits with pre-prepared clip contacts are available for connecting the shields of power cables used for Power Modules.

All cables inside the cabinet must be connected as closely as possible to parts connected with cabinet ground, such as a mounting plate or cabinet wall. Ducts made of sheet steel or routing cables between between steel sheets (e.g. between the mounting plate and back wall) should provide adequate shielding.

Avoid, where possible, routing non-shielded cables, connected to the drive line-up, in the immediate vicinity of noise sources, e.g. transformers. Signal cables (shielded and unshielded) connected to the drive line-up must be laid at a great distance from strong external magnetic sources (e.g. transformers, line reactors). In both cases, a distance of ≥ 300 mm is usually sufficient.

Routing 24 V cables

When routing 24 V cables, the following must also be observed:

- No more than 1 conductor pair may be bundled together.
- 24 V conductors must be routed separately from other cables and conductors that could conduct the operating current.
- 24 V cables must never be routed parallel to power cables.
- 24 V cables as well as power cables should be routed to the components so that they never cover ventilation slots

Conditions of use for 24 V cables

- Ambient temperature 55 °C
- Limit conductor temperature, $\leq 70^{\circ}$ C for operation with the rated load current
- Cable length up to 30 m for 24-V power supply cables or for signal cables without additional circuit elements

10.5 24 V DC Supply Voltage

10.5.1 General information

The 24 V DC voltage is required for the power supply:

1. The load voltage of the Control Unit digital outputs
The Control Units are supplied with power via the PM-IF. 24 V must also be connected in the following cases:
 - Commissioning / diagnostics when the Power Module power supply is switched-out.
 - Using the digital outputs CU305
2. The electronics of Sensor Modules
3. The Safe Brake Relay (motor holding brakes)

Other loads must only be connected to these power supply units if they are separately protected from overcurrent.

Note

The electronics power supply must be set up by the user as described in Chapter System data (Page 29).

When connecting to a "DC power supply" in the sense of EN 60204-1:1997, Chapter 4.3.3, functional faults can occur due to the voltage interruptions that are permitted there.

NOTICE

Damage to loads due to overvoltage

An overvoltage from switched inducted loads (contactors, relays) can damage connected loads.
--

- | |
|--|
| <ul style="list-style-type: none">• Install suitable surge protection. |
|--|

Note

Malfunction because 24 V supply voltage is too low

If the 24 V supply voltage falls short of the specified minimum value on a device in the assembly, a malfunction can occur.

- Select an input voltage that is high enough to ensure a sufficient voltage on the last device.
- Do not exceed the maximum value for the supply voltage.
- If required, supply the voltage to the assembly at various locations.

Note

Voltage supply to motor holding brakes

A regulated DC power supply is required to operate motors with a built-in holding brake. The power is supplied via the 24 V connection (Safe Brake Relay). The voltage tolerances of the motor holding brakes ($24\text{ V} \pm 10\%$) and the voltage drops of the connection cables must be taken into account.

The DC power supply should be set to 26 V. This ensures that the power supply for the brake remains within the permissible range when the following conditions are fulfilled:

- Use of Siemens three-phase motors
 - Use of Siemens MOTION-CONNECT power cables
 - Motor cable lengths: max. 100 m
-

10.5.2 Overcurrent protection

The cables on the primary and secondary sides of the 24 V power supply unit must be protected against overcurrent.

Primary side protection must be implemented according to the manufacturer's instructions.

Secondary side protection depends on the prevailing situation. Please note the following:

- Loading due to loads, including simultaneity factor depending on machine operation
- Current carrying capacity of the conductors used and cables in normal and short-circuit conditions
- Ambient temperature
- Cable bundling (routing cables in a common duct)
- Cable routing method according to EN 60204-1

The overcurrent protection devices can be determined according to EN 60204-1, Section 14.

Circuit-breakers from Siemens Catalogs LV 1 and LV 1T are recommended as overcurrent protection devices on the primary side.

Miniature circuit-breakers or SITOP select (Article No. 6EP1961-2BA00) are recommended as overcurrent protection devices on the secondary side. The miniature circuit-breakers can also be selected from Siemens LV 1 and LV 1T Catalogs.

Miniature circuit-breakers are recommended as overcurrent protection devices for the cables and busbars. The ground potential M must be connected to the PE conductor system (PELV / SELV).

When selecting the miniature circuit-breaker, local installation regulations must be carefully complied with.

Table 10- 1 MCBs by conductor cross section and temperature

Conductor cross section	Max. value up to 40° C	Max. value up to 55° C
1.5 mm ²	10 A	6 A
2.5 mm ²	16 A	10 A
4 mm ²	25 A	16 A
6 mm ²	32 A	20 A

The tripping characteristic of the circuit-breaker is selected so that loads remain protected against the maximum current that occurs in the event of a short circuit of the power supply unit.

10.5.3 Overvoltage protection

Surge protection devices are required for cable lengths greater than 30 m.

The following Weidmüller overvoltage protectors are recommended for protecting the components' 24 V power supply and the 24 V signal cables from overvoltage:

Table 10- 2 Recommendations for overvoltage protection

24 V power supply	24 V signal cables
Weidmüller Item no.: PU III R 24V Article No.: 8860360000	Weidmüller Item no.: MCZ OVP TAZ Article No.: 844915 0000

The overvoltage protectors must always be placed next to the area to be protected, e.g. at the entry point to the cabinet.

10.5.4 Typical 24 V current consumption of the components

A separate 24 V power supply must be used for the SINAMICS S110 drive line-up.

The following table can be used to calculate the 24 V DC power supply. The values for typical current consumption are used as a basis for configuration.

Table 10- 3 Overview of 24 V DC current consumption

Component	Typical current consumption [A _{DC}]
Control Units	
CU305 PN without load	0.8
Per digital output	0.1
CU305 DP without load	0.8
Per digital output	0.1
CU305 CAN without load	0.8
Per digital output	0.1
DRIVE-CLiQ and brake	
DRIVE-CLiQ (e.g. motors with DRIVE-CLiQ interface)	Typ. 0.25/Max. 0.45
Brake (e.g. motor holding brake)	Typ. 0.4 to 1.1/Max. 2
Sensor Modules Cabinet	
SMC10 without/with encoder system	0.20 / 0.35
SMC20 without/with encoder system	0.20 / 0.35
SMC30 without/with encoder system	0.20 / 0.55

10.5 24 V DC Supply Voltage

Component	Typical current consumption [A _{bc}]
Sensor Module External	
SME20 without/with encoder system	0.15 / 0.25
SME25 without/with encoder system	0.15 / 0.25
SME120 without/with encoder system	0.20 / 0.30
SME125 without/with encoder system	0.20 / 0.30

10.5.5 Selecting power supply units

You are advised to use the devices in the following table. These devices meet the applicable requirements of EN 60204-1.

Table 10- 4 Recommended SITOP Power

Rated output current [A]	Phases	Rated input voltage [V] Operating voltage range [V]	Short-circuit current [A]	Article No.
5	1 / 2	AC 120 ... 230 / 230 ... 500 85 ... 264 / 176 ... 550	Approx. 5.5 (power up) Typ. 15 for 25 ms (operation)	6EP1333-3BA00-8AC0
10	1 / 2	AC 120 ... 230 / 230 ... 500 85 ... 264 / 176 ... 550	Approx. 12 (power up) Typ. 30 for 25 ms (operation)	6EP1334-3BA00-8AB0
20	1 / 2	AC 120 / 230 85 ... 132 / 176 ... 264	Approx. 23 (power up) Typ. 60 for 25 ms (operation)	6EP1336-3BA00-8AA0
	3	3 AC 230 / 400 ... 288 / 500 320 ... 550		6EP1436-3BA00-8AA0
40	1 / 2	AC 120 / 230 85 ... 132 / 176 ... 264	Approx. 46 (power up) Typ. 120 for 25 ms (operation)	6EP1337-3BA00-8AA0
	3	3 AC 230 / 400 ... 288 / 500 320 ... 550		6EP1437-3BA00-8AA0

Table 10- 5 Recommendation for Control Supply Module

Rated output current [A]	Phases	Input voltage range [V]	Short-circuit current [A]	Article No.
20	3	3-phase 380 V AC -10 % (-15 % < 1 min) to 480 V AC +10% DC 300 ... 800	< 24	6SL3100-1DE22-0AAx

You will find more information on power supply units in catalogs PM21 and NC61.



! WARNING

Danger to life through a hazardous voltage when connecting an unsuitable power supply

Touching live components can result in death or severe injury.

- Connect the ground potential to the PE conductor connection.
- Mount the power supply close to the drive lineup.

Ideally, they should be mounted on a common mounting plate. If different mounting plates are used, their electrical interconnection must comply with the EMC installation guideline.

10.6 Protective connection and equipotential bonding

Protective connections

The SINAMICS S drive system is designed for use in cabinets with a PE conductor connection.

The PE conductor connection of the SINAMICS components must be connected to the PE conductor connection of the control cabinet as follows:

Table 10- 6 Conductor cross section for copper PE connections

Line supply cable in mm ²	Copper PE connection in mm ²
Up to 16 mm ²	The same as the line supply cable
From 16 mm ² to 35 mm ²	16 mm ²
From 35 mm ²	0.5 x line supply cable

For materials other than copper, the cross-section should be increased so that as a minimum, the same conductivity is attained.

All system components and machine parts must be incorporated in the protection concept.

The protective connection (PE connection) of the motors used must be established through the motor cable. For EMC reasons, the shield of the motor cable should be connected through a large surface area both at the Power Module as well as at the motor.

The drive line-up must be arranged on a common metallic bright mounting plate in order to comply with the EMC limit values. The mounting plate must be connected to the PE conductor connection of the cabinet through a low impedance.

Copper cables with appropriate cross sections (>2.5 mm²) must be used for the ground connection of PROFIBUS nodes.

For more information about grounding PROFIBUS, see:

http://www.profibus.com/fileadmin/media/wbt/WBT_Assembly_V10_Dec06/start.html

Functional equipotential bonding with PE conductor connection

A mounting plate, which is connected with the PE conductor connection of the cabinet through a low impedance connection, simultaneously serves as the functional equipotential bonding surface. This means that no additional functional equipotential bonding is required within the drive line-up.

If a common metallic bright mounting plate is not available, equally good equipotential bonding must be ensured using the conductor cross sections listed in the table above or with at least the same conductivity.

When installing components on standard mounting rails, the data listed in the table also apply to the functional equipotential bonding. If only smaller connection cross sections are permissible at the components, the largest possible cross section should be used, e.g. 6 mm² for SMC. These requirements also apply to distributed components located outside the cabinet.

NOTICE
Damage to components as a result of high leakage currents
The Control Unit or other PROFIBUS and/or PROFINET nodes can be damaged if substantial leakage currents flow through the PROFIBUS or PROFINET cable.
<ul style="list-style-type: none">• Use a functional equipotential bonding conductor with a cross section of at least 25 mm² between components of an installation that are located at a distance from each other.

No functional equipotential bonding conductors are required for PROFIBUS inside a cabinet. For PROFIBUS connections between different buildings or parts of buildings, a functional equipotential bonding must be routed in parallel to the PROFIBUS cable. The following cross sections must be observed in accordance with IEC 60364-5-54:

- Copper 6 mm²
- Aluminum 16 mm²
- Steel 50 mm²

You will find more information on equipotential bonding for PROFIBUS at:
http://www.profibus.com/fileadmin/media/wbt/WBT_Assembly_V10_Dec06/start.html

NOTICE
Damage to equipment due to inadequate functional equipotential bonding
Failure to heed the information provided above for functional equipotential bonding can cause the faults in devices and disturb fieldbus interfaces.

Note

PROFINET

You will find installation guidelines and information on protective grounding and equipotential bonding for all PROFINET types and topologies under DOWNLOADS at:
<http://www.profibus.com>

10.7 Notes on electrical cabinet cooling

10.7.1 General information

Cabinets can be cooled in a number of ways including the following:

- Filtered fans
- Heat exchanger
- Cooling unit

The decision in favor of one of these methods will depend on the prevailing ambient conditions and the cooling power required.

The air routing within the cabinet and the ventilation clearances specified here must be ensured. Other components or cables must not be installed in these areas.

You must comply with the following specifications when installing SINAMICS components:

- Ventilation clearance
- Cable routing
- Air guidance, air-conditioner

Table 10-7 Ventilation clearances around the components

Component	Clearance above and below in mm und (inch)	Clearance in front of the component in mm und (inch)
CU305 PN	50 (1.97)	0
CU305 DP	50 (1.97)	0
CU305 CAN	50 (1.97)	0
SMCxx	50 (1.97)	0
Line filter	100 (3.94)	0
Line reactor	100 (3.94)	0
PM240-2 Blocksize, frame size FSA ... FSC	Above: 80 (3.15) Below: 100 (3.94)	0
PM240-2 Blocksize, frame size FSD ... FSE	Above: 300 (11.81) Below: 350 (13.78)	100 (3.94)
Motor reactor	100 (3.94)	0
Braking resistor (vertical installation)	Above: 1000 (39.37)	All around: 100 (3.94)
Braking resistor (horizontal installation)	Above: 1000 (39.37)	All around: 250 (9.84)

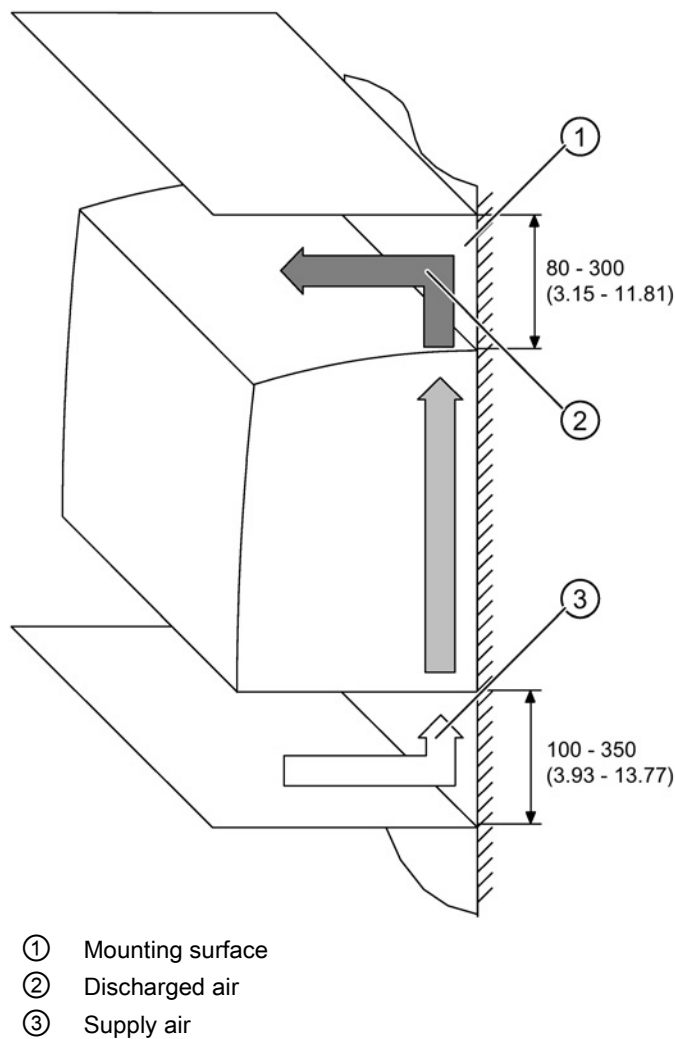

Figure 10-2 Ventilation clearances

10.7.2 Ventilation

The SINAMICS equipment is ventilated separately by means of integrated fans and is in some cases cooled by means of natural convection.

The cooling air must flow by the components from the bottom (cool area) to the top (area warmed through operation).

If filtered fans, heat exchangers, or air conditioners are used, you must ensure that the air is flowing in the right direction. You must also ensure that the warm air can escape at the top. The ventilation clearance above and below must be ensured.

NOTICE**Damage caused by overheating**

Overheating can cause system damage.

- Install the components with the specified orientation.
- Maintain the minimum clearances to other components.
- Install suitable ventilation in the cabinet to dissipate the power loss of the individual components.
- Install suitable air filters and keep the heat sink clean.
- Ensure that the components are provided with adequate cooling air through the cooling openings. In particular, the connected signal and power cables must not cover the ventilation openings.
- Ensure that the cooling air flow is not blocked by other devices or mix with the exhaust air from other devices. If necessary, insert air baffles.

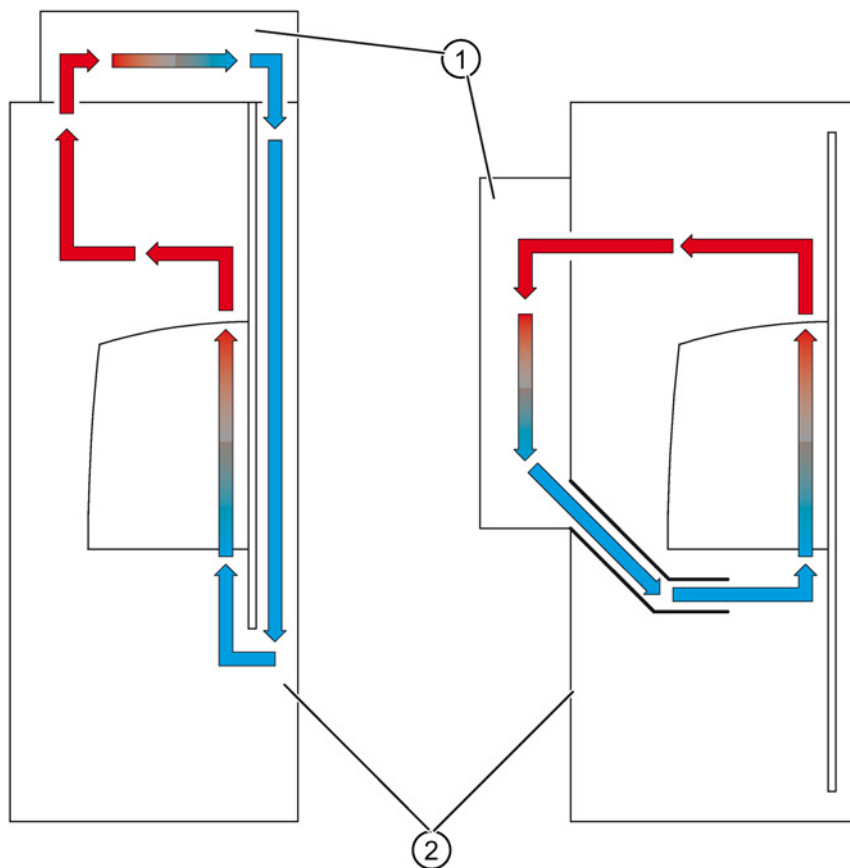

- ① Cooling unit
② Cabinet

Figure 10-3 Examples of cabinet ventilation

If air conditioners are used, you must consider that the relative air humidity of the expelled air increases as the air in the air conditioner cools and may exceed the dew point. If the relative humidity of the air entering the SINAMICS equipment is over 80% for an extended period of time, the insulation in the equipment may fail to function properly due to electrochemical reactions (see Chapter System overview (Page 25)). Using air baffle plates, for example, you must ensure that the cold air expelled from the air conditioner mixes with warm air in the cabinet before it enters the unit. This reduces the relative air humidity to uncritical values.

NOTICE

Damage caused by condensation

Condensation on the components can result in their failure.

- Select the air guidance and arrangement of the cooling equipment in such a way that no condensation can form on the components. The distance between the discharge opening of the air condition equipment and the electronic equipment must be at least 200 mm.
- If required, install cabinet heating.

10.7.3 Power loss of components during rated operation

10.7.3.1 General information

The tables below give details of power loss for components during rated operation. The characteristic values apply for the following conditions:

- Line voltage for Power Modules:
 - 1/3 AC 200 ... 240 V with permissible deviation
 - 3 AC 380 ... 480 V with permissible deviation
- Rated pulse frequency of the Power Modules
- Operating components at their unit rating

10.7.3.2 Power loss for Control Units and Sensor Modules

Table 10- 8 Overview of power loss during rated operation for Control Units and Sensor Modules

Component	Unit	Power loss
Control Units		
CU305 PN	W	< 20
CU305 DP	W	< 20
CU305 CAN	W	< 20
Sensor Modules		
SMC10	W	< 10
SMC20	W	< 10
SMC30	W	< 10

10.7.3.3 Power loss for line reactors and line filters

Table 10- 9 Overview of power loss during rated operation for line reactors and line filters

Rated output current I_n	Frame size	Line supply voltage	Unit	Power loss 50/60 Hz
Line reactors for Power Modules PM240-2				
4.0 A	FSA (1.1 kW)	3-phase 380 ... 480 V AC	W	23 / 25.3
11.3 A	FSA (4.0 kW)	3-phase 380 ... 480 V AC	W	36 / 39.6
22.3 A	FSB	3-phase 380 ... 480 V AC	W	53 / 58.3
47.0 A	FSC	3-phase 380 ... 480 V AC	W	88 / 96.8
Line filters for Power Modules PM240-2				
11.4 A	FSA	3-phase 380 ... 480 V AC	W	13
23.5 A	FSB	3-phase 380 ... 480 V AC	W	22
49.4 A	FSC	3-phase 380 ... 480 V AC	W	39

10.7.3.4 Power loss for Power Modules

Table 10- 10 Overview of power loss during rated operation for Power Modules

Rated output current I_{rated} /Unit rating based on I_{rated}	Frame size	Line supply voltage	Unit	Power loss
PM240-2 Blocksize				
7.5 A / 0.55 kW	FSA	1/3 AC 200 ... 240 V	kW	0.04
9.6 A / 0.75 kW	FSA	1/3 AC 200 ... 240 V	kW	0.04
13.5 A / 1.1 kW	FSB	1/3 AC 200 ... 240 V	kW	0.05
18.1 A / 1.5 kW	FSB	1/3 AC 200 ... 240 V	kW	0.07
24.0 A / 2.2 kW	FSB	1/3 AC 200 ... 240 V	kW	0.12
35.9 A / 3.0 kW	FSC	1/3 AC 200 ... 240 V	kW	0.14
43.0 A / 4.0 kW	FSC	1/3 AC 200 ... 240 V	kW	0.18

10.7 Notes on electrical cabinet cooling

Rated output current I_{rated} /Unit rating based on I_{rated}	Frame size	Line supply voltage	Unit	Power loss
2.3 A / 0.55 kW	FSA	3-phase 380 ... 480 V AC	kW	0.04
2.9 A / 0.75 kW	FSA	3-phase 380 ... 480 V AC	kW	0.04
4.1 A / 1.1 kW	FSA	3-phase 380 ... 480 V AC	kW	0.04
5.5 A / 1.5 kW	FSA	3-phase 380 ... 480 V AC	kW	0.07
7.7 A / 2.2 kW	FSA	3-phase 380 ... 480 V AC	kW	0.10
10.1 A / 3.0 kW	FSA	3-phase 380 ... 480 V AC	kW	0.12
13.3 A / 4.0 kW	FSB	3-phase 380 ... 480 V AC	kW	0.11
17.2 A / 5.5 kW	FSB	3-phase 380 ... 480 V AC	kW	0.15
22.2 A / 7.5 kW	FSB	3-phase 380 ... 480 V AC	kW	0.20
32.6 A / 11.0 kW	FSC	3-phase 380 ... 480 V AC	kW	0.30
39.9 A / 15.0 kW	FSC	3-phase 380 ... 480 V AC	kW	0.37
44 A / 18.5 kW	FSD	3-phase 380 ... 480 V AC	kW	0.55
52 A / 22 kW	FSD	3-phase 380 ... 480 V AC	kW	0.68
70 A / 30 kW	FSD	3-phase 380 ... 480 V AC	kW	0.76
77 A / 37 kW	FSD	3-phase 380 ... 480 V AC	kW	1.01
93 A / 45 kW	FSE	3-phase 380 ... 480 V AC	kW	1.19
113 A / 55 kW	FSE	3-phase 380 ... 480 V AC	kW	1.54
PM240-2 Blocksize Push Through				
9.6 A / 0.75 kW	FSA	1/3 AC 200 ... 240 V	kW	0.04
24.0 A / 2.2 kW	FSB	1/3 AC 200 ... 240 V	kW	0.12
43.0 A / 4.0 kW	FSC	1/3 AC 200 ... 240 V	kW	0.18
10.1 A / 3.0 kW	FSA	3-phase 380 ... 480 V AC	kW	0.12
22.2 A / 7.5 kW	FSB	3-phase 380 ... 480 V AC	kW	0.20
39.9 A / 15.0 kW	FSC	3-phase 380 ... 480 V AC	kW	0.37

10.7.3.5 Power losses for motor reactors

Table 10- 11 Overview of power losses for nominal operation for motor reactors

Rated current I_n	Frame size	Line supply voltage	Unit	Power loss
6.1 A	FSA/FSB	200 ... 240 V 1/3 AC 380 ... 480 V 3 AC	kW	0.09
9.0 A	FSA/FSB	200 ... 240 V 1/3 AC 380 ... 480 V 3 AC	kW	0.08
18.5 A	FSB/FSC	200 ... 240 V 1/3 AC 380 ... 480 V 3 AC	kW	0.08
39.0 A	FSC/FSD	3-phase 380 ... 480 V AC	kW	0.11
45 A	FSD	3-phase 380 ... 480 V AC	kW	0.20
90 A	FSD/FSE	3-phase 380 ... 480 V AC	kW	0.27
178 A	FSE	3-phase 380 ... 480 V AC	kW	0.47

11.1 Safety instructions for service and maintenance

 WARNING
Danger to life if the fundamental safety instructions and residual risks are not observed The non-observance of the fundamental safety instructions and residual risks stated in Chapter 1 can result in accidents with severe injuries or death. <ul style="list-style-type: none">• Observe the fundamental safety instructions.• Consider the residual risks for the risk evaluation.



 DANGER
Danger to life due to electric shock caused by residual charge of the DC-link capacitors Due to the DC-link capacitors, a hazardous voltage is present in the DC link for up to five minutes after the power supply has been switched off. Touching live components results in death or severe injury. <ul style="list-style-type: none">• Only carry out work on these components after this time has elapsed.• Measure the voltage before starting work on the DCP and DCN DC-link terminals.



 WARNING
Danger to life due to electric shock from external supply voltage If the auxiliary 230 VAC supplies are present, then a hazardous voltage is present at the components even when the main switch is in the open state. Death or serious injury can result when live parts are touched. <ul style="list-style-type: none">• Disconnect the existing auxiliary supply circuits from the supply.

 WARNING
Danger to life due to improper transport or installation of devices and components Serious injury or even death and substantial material damage can occur if the devices are not transported or installed properly. <ul style="list-style-type: none">• Transport, mount, and remove the devices and components only if you are qualified to do so.• Take into account that the devices and components are in some cases heavy and top-heavy and take the necessary precautionary measures.

11.2 Service and maintenance for components, Blocksize format

11.2.1 Replacing hardware components

The following components can be replaced with replacement components with the same Article No.:

- Power Modules
- DRIVE-CLiQ components
- Control Units

11.2.2 Replacing the fan on the PM240-2

Fans are available as spare parts for all PM240-2 installation sizes. For frame sizes FSA and FSB the fan module has one fan, for frame sizes FSC to FSE, two fans.

For frame sizes FSA ... FSC the fan module is installed below. For frame sizes FSD ... FSE it is located at the top.

Note

Only trained personnel must replace the fan, observing ESD guidelines.

Procedure for replacing the fan module FSA - FSC

1. Switch-off the inverter, and wait 5 minutes until the DC link capacitors have been discharged.
2. Withdraw the line and motor cable connectors and, if available, remove the braking resistor from the Power Module.
3. Remove the shield plate from the Power Module.

- Remove the fan module from the Power Module as shown in the diagram.

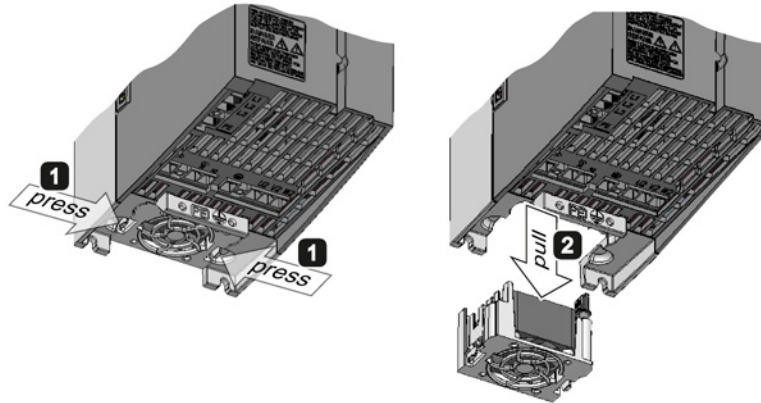

Figure 11-1 Pull out the fan on PM240-2 FSA to FSC

- Install the new fan module in the inverse sequence.
- Reconnect all cable connectors.

Procedure for replacing the fan module FSD and FSE

- Switch-off the inverter, and wait 5 minutes until the DC link capacitors have been discharged.
- Pull the fan module out of the Power Module. No tools are required for this. Pulling out the fan module also disconnects the electrical connections.

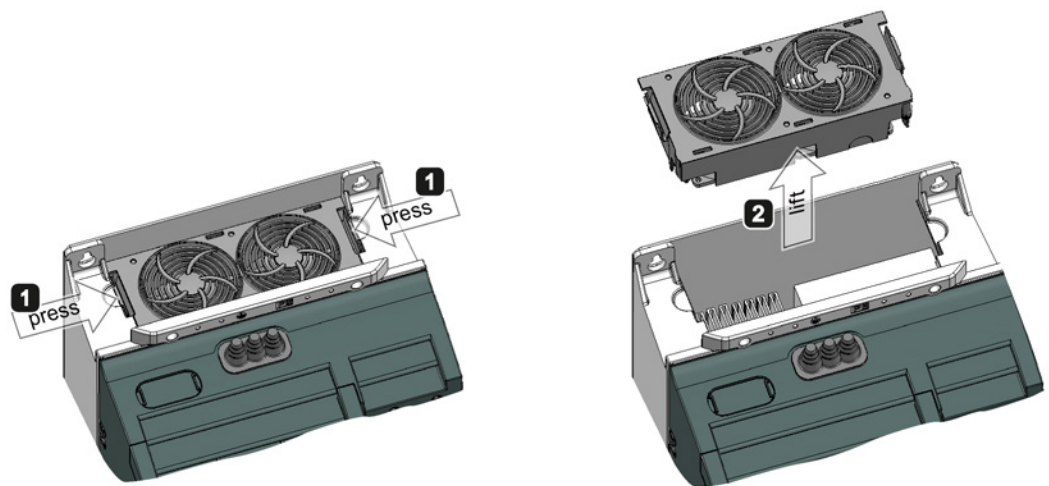

Figure 11-2 Removing the fan from PM240-2 FSD and FSE

- Install the new fan module in the inverse sequence.

11.3 Forming the DC link capacitors

NOTICE
Damage in the case of long storage periods
After being in storage for more than two years, the components may suffer damage when switched on.
<ul style="list-style-type: none"> Form the DC link capacitors of the Power Module again.

If the cabinet is commissioned within two years of its date of manufacture, the DC link capacitors do not need to be reformed. The date of manufacture can be taken from the serial number on the rating plate.

Note

The storage period starts from the date of manufacture and not from the date on which the equipment was shipped.

Date of manufacture

The date of manufacture can be determined from the following assignment to the serial number (e.g. T-A92067000015 for 2010, September):

Table 11- 1 Production year and month

Character	Year of manufacture	Character	Month of manufacture
A	2010	1 to 9	January to September
B	2011	O	October
C	2012	N	November
D	2013	D	December
E	2014		
F	2015		
G	2016		
H	2017		
J	2018		
K	2019		
L	2020		
M	2021		
N	2022		

The serial number is found on the rating plate.

When DC link capacitors are formed, a defined voltage is connected to them and a defined current flows so that the appropriate capacitor characteristics are restored for them to be re-used as DC link capacitors.

Forming circuit

The forming circuit can be built using incandescent lamps or, alternatively, resistors.

Components required for reforming outside the drive line-up

- 1 fuse switch, triple 400 V / 10 A or double 230 V / 10 A
- Cable 1.5 mm²
- 3 incandescent lamps 230 V / 100 W for a line voltage of 3-phase 380 - 480 V AC. Alternatively, use 3 resistors of 1 k Ω / 100 W each (e.g. GWK150J1001KLX000 from Vishay) instead of the incandescent lamps.
- 2 incandescent lamps 230 V / 100 W for a line voltage of 1-phase 200 - 240 V AC. Alternatively, use 2 resistors of 1 k Ω / 100 W each (e.g. GWK150J1001KLX000 from Vishay) instead of the incandescent lamps.
- Sundry accessories, such as lamp socket, etc.

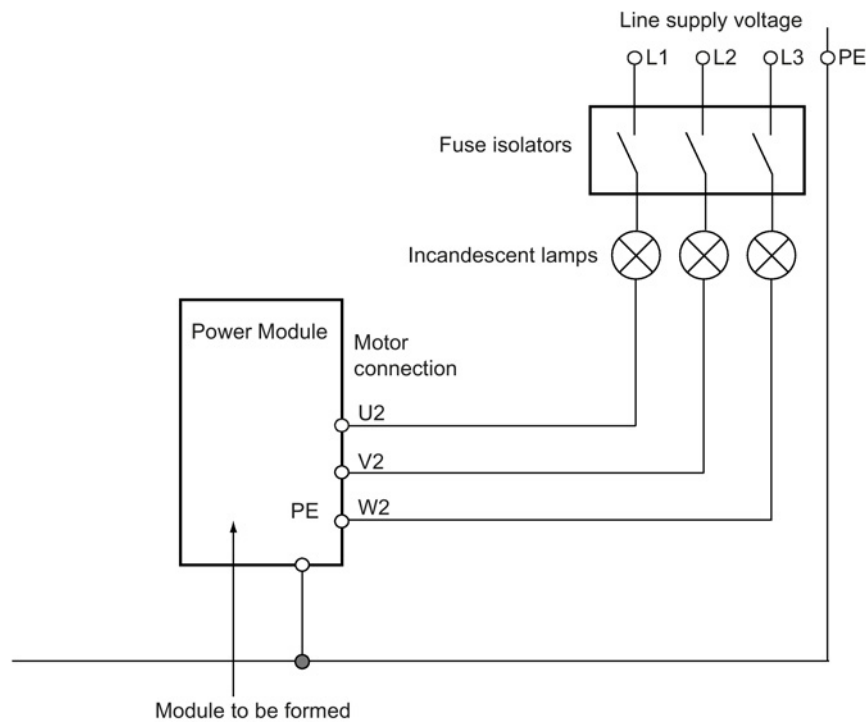

Figure 11-3 Forming circuit for 3-phase AC Power Modules with incandescent lamps

11.3 Forming the DC link capacitors

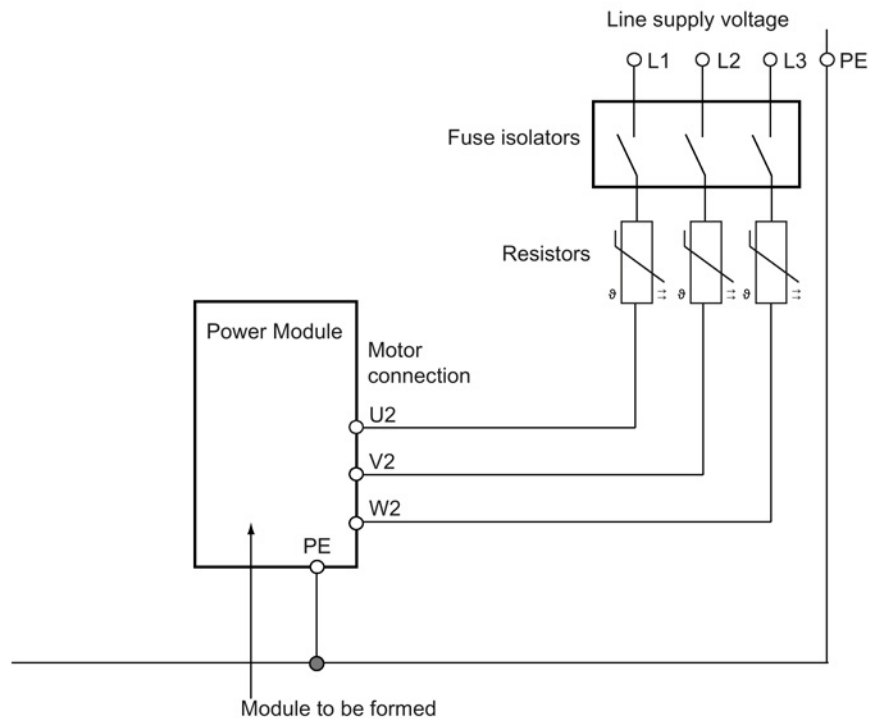

Figure 11-4 Forming circuit for 3-phase AC Power Modules with resistors

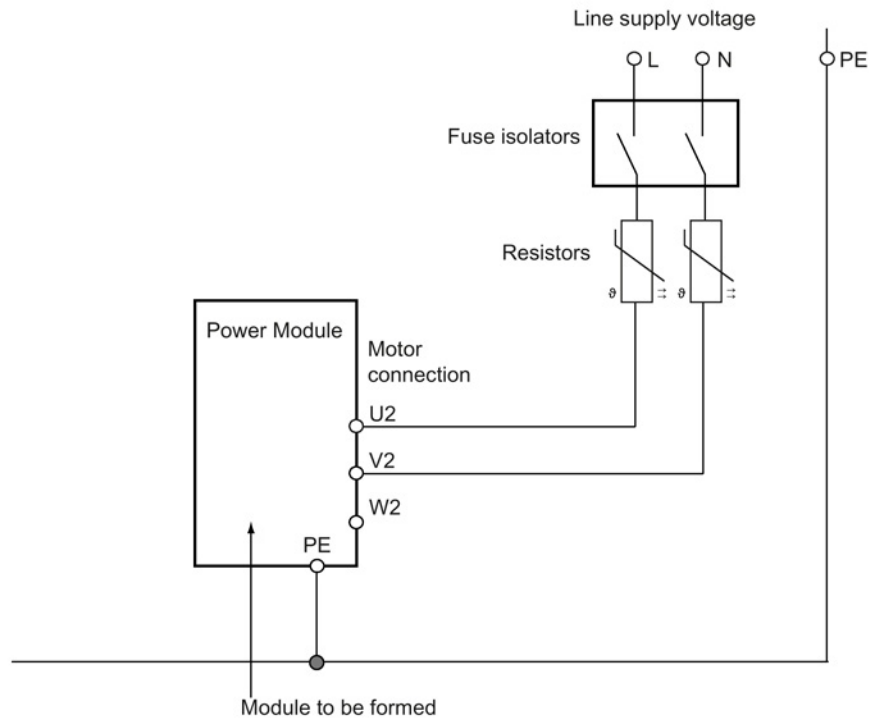

Figure 11-5 Forming circuit for 1-phase AC Power Modules with resistors

Procedure

- Make sure that the device **does not** receive a power-on command (e.g. from the keyboard or terminal block).
- Connect the forming circuit.
- While forming, the incandescent lamps must become less bright or go completely dark. If the incandescent lamps continue to be brightly lit, a fault has occurred in the drive unit or in the wiring.
- To form using resistors, the modules must remain in the circuit for approx. 1 h. The resistors will become very hot if there is a fault in the unit (surface temperature > 80 °C).

11.4 Spare parts

Spare parts are available on the Internet at:

<http://support.automation.siemens.com/WW/view/de/16612315>

11.5 Recycling and disposal

Dispose of the product according to the applicable national regulations.

The products described in this Equipment Manual are extensively recyclable on account of the low-toxic composition of the materials used. To recycle and dispose of your old device in an environmentally friendly way, please contact a company that disposes of electronic waste.

A.1 List of abbreviations

Note

The following list of abbreviations includes all abbreviations and their meanings used in the entire SINAMICS family of drives.

Abbreviation	Source of the abbreviation	Meaning
A		
A...	Alarm	Alarm
AC	Alternating Current	Alternating current
ADC	Analog Digital Converter	Analog-digital converter
AI	Analog Input	Analog input
AIM	Active Interface Module	Active Interface Module
ALM	Active Line Module	Active Line Module
AO	Analog Output	Analog output
AOP	Advanced Operator Panel	Advanced Operator Panel
APC	Advanced Positioning Control	Advanced Positioning Control
AR	Automatic Restart	Automatic restart
ASC	Armature Short-Circuit	Armature short-circuit
ASCII	American Standard Code for Information Interchange	American standard code for information interchange
AS-i	AS-Interface (Actuator Sensor Interface)	AS interface (open bus system in automation technology)
ASM	Asynchronmotor	Induction motor
B		
BB	Betriebsbedingung	Operating condition
BERO	-	Proximity switch
BI	Binector Input	Binector Input
BIA	Berufsgenossenschaftliches Institut für Arbeitssicherheit	BG Institute for Occupational Safety and Health
BICO	Binector Connector Technology	Binector connector technology
BLM	Basic Line Module	Basic Line Module

A.1 List of abbreviations

Abbreviation	Source of the abbreviation	Meaning
BO	Binector Output	Binector output
BOP	Basic Operator Panel	Basic Operator Panel
C		
C	Capacitance	Capacitance
C...	-	Safety message
CAN	Controller Area Network	Serial bus system
CBC	Communication Board CAN	Communication Board CAN
CBE	Communication Board Ethernet	PROFINET communication module (Ethernet)
CD	Compact Disc	Compact disk
CDS	Command Data Set	Command data set
CF Card	CompactFlash Card	CompactFlash card
CI	Connector Input	Connector Input
CLC	Clearance Control	Clearance control
CNC	Computer Numerical Control	Computerized numerical control
CO	Connector Output	Connector output
CO/BO	Connector Output/Binector Output	Connector/binector output
COB ID	CAN Object-Identification	CAN object identification
CoL	Certificate of License	Certificate of License
COM	Common contact of a change-over relay	Center contact on a changeover contact
COMM	Commissioning	Commissioning
CP	Communication Processor	Communications processor
CPU	Central Processing Unit	Central processing unit
CRC	Cyclic Redundancy Check	Cyclic redundancy check
CSM	Control Supply Module	Control Supply Module
CU	Control Unit	Control unit
CUA	Control Unit Adapter	Control Unit Adapter
CUD	Control Unit DC MASTER	Control Unit DC MASTER
D		
DAC	Digital Analog Converter	Digital-analog converter
DC	Direct Current	Direct current
DCB	Drive Control Block	Drive Control Block
DCBRK	DC Brake	DC braking
DCC	Drive Control Chart	Drive Control Chart
DCN	Direct Current Negative	Direct current negative
DCP	Direct Current Positive	Direct current positive
DDS	Drive Data Set	Drive data set
DI	Digital Input	Digital input
DI/DO	Digital Input/Digital Output	Bidirectional digital input/output
DMC	DRIVE-CLiQ Hub Module Cabinet	DRIVE-CLiQ Hub Module Cabinet
DME	DRIVE-CLiQ Hub Module External	DRIVE-CLiQ Hub Module External

Abbreviation	Source of the abbreviation	Meaning
DMM	Double Motor Module	Double Motor Module
DO	Digital Output	Digital output
DO	Drive Object	Drive object
DP	Decentralized Peripherals	Distributed I/O
DPRAM	Dual Ported Random Access Memory	Dual-Port Random Access Memory
DQ	DRIVE-CLiQ	DRIVE-CLiQ
DRAM	Dynamic Random Access Memory	Dynamic Random Access Memory
DRIVE-CLiQ	Drive Component Link with IQ	Drive Component Link with IQ
DSC	Dynamic Servo Control	Dynamic Servo Control
DTC	Digital Time Clock	Timer
E		
EASC	External Armature Short-Circuit	External armature short-circuit
EDS	Encoder Data Set	Encoder data set
EEPROM	Electrically Erasable Programmable Read-Only Memory	Electrically Erasable Programmable Read-Only-Memory
ESD	Elektrostatisch gefährdete Baugruppen	Electrostatic sensitive devices
ELCB	Earth Leakage Circuit Breaker	Residual current operated circuit breaker
ELP	Earth Leakage Protection	Ground-fault monitoring
EMC	Electromagnetic Compatibility	Electromagnetic compatibility
EMF	Electromotive Force	Electromotive force
EMK	Elektromotorische Kraft	Electromotive force
EMV	Elektromagnetische Verträglichkeit	Electromagnetic compatibility
EN	Europäische Norm	European standard
EnDat	Encoder-Data-Interface	Encoder interface
EP	Enable Pulses	Enable pulses
EPOS	Einfachpositionierer	Basic positioner
ES	Engineering System	Engineering System
ESB	Ersatzschaltbild	Equivalent circuit diagram
ESD	Electrostatic Sensitive Devices	Electrostatic sensitive devices
ESM	Essential Service Mode	Essential service mode
ESR	Extended Stop and Retract	Extended stop and retract
F		
F...	Fault	Fault
FAQ	Frequently Asked Questions	Frequently asked questions
FBLOCKS	Free Blocks	Free function blocks
FCC	Function Control Chart	Function control chart
FCC	Flux Current Control	Flux current control
FD	Function Diagram	Function diagram
F-DI	Failsafe Digital Input	Fail-safe digital input
F-DO	Failsafe Digital Output	Fail-safe digital output

A.1 List of abbreviations

Abbreviation	Source of the abbreviation	Meaning
FEM	Fremderregter Synchronmotor	Separately excited synchronous motor
FEPROM	Flash-EPROM	Non-volatile write and read memory
FG	Function Generator	Function generator
FI	-	Residual current
FOC	Fiber-Optic Cable	Fiber-optic cable
FP	Funktionsplan	Function diagram
FPGA	Field Programmable Gate Array	Field programmable gate array
FW	Firmware	Firmware
G		
GB	Gigabyte	Gigabyte
GC	Global Control	Global control telegram (broadcast telegram)
GND	Ground	Reference potential for all signal and operating voltages, usually defined as 0 V (also referred to as M)
GSD	Gerätstammdatei	Generic station description: describes the features of a PROFIBUS slave
GSV	Gate Supply Voltage	Gate supply voltage
GUID	Globally Unique Identifier	Globally Unique Identifier
H		
HF	High frequency	High frequency
HFD	Hochfrequenzdrossel	High-frequency reactor
HLA	Hydraulic Linear Actuator	Hydraulic linear drive
HLG	Hochlaufgeber	Ramp-function generator
HM	Hydraulic Module	Hydraulic Module
HMI	Human Machine Interface	Human machine interface
HTL	High-Threshold Logic	Logic with high fault threshold
HW	Hardware	Hardware
I		
i. V.	In Vorbereitung	Under development: This property is currently not available
I/O	Input/Output	Input/output
I2C	Inter-Integrated Circuit	Internal serial data bus
IASC	Internal Armature Short-Circuit	Internal armature short-circuit
IBN	Inbetriebnahme	Commissioning
ID	Identifier	Identification
IE	Industrial Ethernet	Industrial Ethernet
IEC	International Electrotechnical Commission	International Electrotechnical Commission
IF	Interface	Interface
IGBT	Insulated Gate Bipolar Transistor	Bipolar transistor with insulated control electrode
IGCT	Integrated Gate-Controlled Thyristor	Semiconductor power switch with integrated control electrode

Abbreviation	Source of the abbreviation	Meaning
IL	Impulslöschung	Pulse suppression
IP	Internet Protocol	Internet Protocol
IPO	Interpolator	Interpolator
IT	Isolé Terre	Non-grounded three-phase line supply
IVP	Internal Voltage Protection	Internal voltage protection
J		
JOG	Jogging	Jog
K		
KDV	Kreuzweiser Datenvergleich	Crosswise data comparison
KHP	Know-how protection	Know-how protection
KIP	Kinetische Pufferung	Kinetic buffering
Kp	-	Proportional gain
KTY	-	Special temperature sensor
L		
L	-	Symbol for inductance
LED	Light Emitting Diode	Light emitting diode
LIN	Linearmotor	Linear motor
LR	Lageregler	Position controller
LSB	Least Significant Bit	Least significant bit
LSC	Line-Side Converter	Line-side converter
LSS	Line-Side Switch	Line-side switch
LU	Length Unit	Length unit
FO cable	Lichtwellenleiter	Fiber-optic cable
M		
M	-	Symbol for torque
M	Masse	Reference potential for all signal and operating voltages, usually defined as 0 V (also referred to as GND)
MB	Megabyte	Megabyte
MCC	Motion Control Chart	Motion Control Chart
MDI	Manual Data Input	Manual data input
MDS	Motor Data Set	Motor data set
MLFB	Maschinenlesbare Fabrikatebezeichnung	Machine-readable product code
MM	Motor Module	Motor Module
MMC	Man-Machine Communication	Man-machine communication
MMC	Micro Memory Card	Micro memory card
MSB	Most Significant Bit	Most significant bit
MSC	Motor-Side Converter	Motor-side converter
MSCY_C1	Master Slave Cycle Class 1	Cyclic communication between master (class 1) and slave

A.1 List of abbreviations

Abbreviation	Source of the abbreviation	Meaning
MSC	Motorstromrichter	Motor-side converter
MT	Messtaster	Probe
N		
N. C.	Not Connected	Not connected
N...	No Report	No report or internal message
NAMUR	Normenarbeitsgemeinschaft für Mess- und Regeltechnik in der chemischen Industrie	Standardization association for measurement and control in chemical industries
NC	Normally Closed (contact)	NC contact
NC	Numerical Control	Numerical control
NEMA	National Electrical Manufacturers Association	Standardization body in the US
NM	Nullmarke	Zero mark
NO	Normally Open (contact)	NO contacts
LSC	Netzstromrichter	Line-side converter
NVRAM	Non-Volatile Random Access Memory	Non-volatile read/write memory
O		
OA	Open Architecture	Software component (technology package) which provides additional functions for the SINAMICS drive system
OAIF	Open Architecture Interface	Version of the SINAMICS firmware from which the OA-application can be used
OASP	Open Architecture Support Package	Expands the STARTER commissioning tool by the corresponding OA-application
OC	Operating Condition	Operating condition
OEM	Original Equipment Manufacturer	Original equipment manufacturer
OLP	Optical Link Plug	Bus connector for fiber-optic cable
OMI	Option Module Interface	Option Module Interface
P		
p...	-	Adjustable parameters
P1	Processor 1	CPU 1
P2	Processor 2	CPU 2
PB	PROFIBUS	PROFIBUS
PcCtrl	PC Control	Master control
PD	PROFIdrive	PROFIdrive
PDS	Power unit Data Set	Power unit data set
PE	Protective Earth	Protective ground
PELV	Protective Extra Low Voltage	Safety extra-low voltage
PEM	Permanenterregter Synchronmotor	Permanent-magnet synchronous motor
PG	Programmiergerät	Programming device
PI	Proportional Integral	Proportional integral
PID	Proportional Integral Differential	Proportional integral differential
PLC	Programmable Logical Controller	Programmable logic controller

Abbreviation	Source of the abbreviation	Meaning
PLL	Phase-Locked Loop	Phase-locked loop
PM	Power Module	Power Module
PN	PROFINET	PROFINET
PNO	PROFIBUS Nutzerorganisation	PROFIBUS user organization
PPI	Point to Point Interface	Point-to-point interface
PRBS	Pseudo Random Binary Signal	White noise
PROFIBUS	Process Field Bus	Serial data bus
PS	Power Supply	Power supply
PSA	Power Stack Adapter	Power Stack Adapter
PTC	Positive Temperature Coefficient	Positive temperature coefficient
PTP	Point To Point	Point-to-point
PWM	Pulse Width Modulation	Pulse width modulation
PZD	Prozessdaten	Process data
Q		
R		
r...	-	Display parameters (read only)
RAM	Random Access Memory	Read/write memory
RCCB	Residual Current Circuit Breaker	Residual current operated circuit breaker
RCD	Residual Current Device	Residual current operated circuit breaker
RCM	Residual Current Monitor	Residual current monitor
RFG	Ramp-Function Generator	Ramp-function generator
RJ45	Registered Jack 45	Term for an 8-pin socket system for data transmission with shielded or non-shielded multi-wire copper cables
RKA	Rückkühlanlage	Cooling unit
RLM	Renewable Line Module	Renewable Line Module
RO	Read Only	Read only
ROM	Read-Only Memory	Read-only memory
RPDO	Receive Process Data Object	Receive Process Data Object
RS232	Recommended Standard 232	Interface standard for cable-connected serial data transmission between a sender and receiver (also known as EIA232)
RS485	Recommended Standard 485	Interface standard for a cable-connected differential, parallel, and/or serial bus system (data transmission between a number of senders and receivers, also known as EIA485)
RTC	Real Time Clock	Realtime clock
RZA	Raumzeigerapproximation	Space vector approximation
S		
S1	-	Continuous duty
S3	-	Intermittent duty
SAM	Safe Acceleration Monitor	Safe acceleration monitoring

A.1 List of abbreviations

Abbreviation	Source of the abbreviation	Meaning
SBC	Safe Brake Control	Safe brake control
SBH	Sicherer Betriebshalt	Safe operating stop
SBR	Safe Brake Ramp	Safe brake ramp monitoring
SBT	Safe Brake Test	Safe brake test
SCA	Safe Cam	Safe cam
SD Card	SecureDigital Card	Secure digital memory card
SDI	Safe Direction	Safe motion direction
SE	Sicherer Software-Endschalter	Safe software limit switch
SG	Sicher reduzierte Geschwindigkeit	Safely-limited speed
SGA	Sicherheitsgerichteter Ausgang	Safety-related output
SGE	Sicherheitsgerichteter Eingang	Safety-related input
SH	Sicherer Halt	Safe standstill
SI	Safety Integrated	Safety Integrated
SIL	Safety Integrity Level	Safety Integrity Level
SLM	Smart Line Module	Smart Line Module
SLP	Safely-Limited Position	Safely-limited position
SLS	Safely-Limited Speed	Safely-limited speed
SLVC	Sensorless Vector Control	Vector control without encoder (sensorless)
SM	Sensor Module	Sensor Module
SMC	Sensor Module Cabinet	Sensor Module Cabinet
SME	Sensor Module External	Sensor Module External
SMI	SINAMICS Sensor Module Integrated	SINAMICS Sensor Module Integrated
SMM	Single Motor Module	Single Motor Module
SN	Sicherer Software-Nocken	Safe software cam
SOS	Safe Operating Stop	Safe operating stop
SP	Service Pack	Service pack
SP	Safe Position	Safe position
SPC	Setpoint Channel	Setpoint channel
SPI	Serial Peripheral Interface	Serial peripheral interface
SPS	Speicherprogrammierbare Steuerung	Programmable logic controller
SS1	Safe Stop 1	Safe stop 1 (monitored for time and ramping up)
SS2	Safe Stop 2	Safe Stop 2
SSI	Synchronous Serial Interface	Synchronous serial interface
SSM	Safe Speed Monitor	Safe feedback from speed monitor
SSP	SINAMICS Support Package	SINAMICS support package
STO	Safe Torque Off	Safe torque off
STW	Steuerwort	Control word

Abbreviation	Source of the abbreviation	Meaning
T		
TB	Terminal Board	Terminal board
TIA	Totally Integrated Automation	Totally Integrated Automation
TM	Terminal Module	Terminal Module
TN	Terre Neutre	Grounded three-phase line supply
Tn	-	Integral time
TPDO	Transmit Process Data Object	Transmit process data object
TT	Terre Terre	Grounded three-phase line supply
TTL	Transistor-Transistor-Logic	Transistor-transistor logic
Tv	-	Rate time
U		
UL	Underwriters Laboratories Inc.	Underwriters Laboratories Inc.
UPS	Uninterruptible Power Supply	Uninterruptible power supply
UPS	Unterbrechungsfreie Stromversorgung	Uninterruptible power supply
UTC	Universal Time Coordinated	Universal time coordinated
V		
VC	Vector Control	Vector control
Vdc	-	DC-link voltage
VdcN	-	Partial DC link voltage, negative
VdcP	-	Partial DC link voltage, positive
VDE	Verband Deutscher Elektrotechniker	Verband Deutscher Elektrotechniker [Association of German Electrical Engineers]
VDI	Verein Deutscher Ingenieure	Verein Deutscher Ingenieure [Association of German Engineers]
VPM	Voltage Protection Module	Voltage Protection Module
Vpp	Volt peak to peak	Volt peak to peak
VSM	Voltage Sensing Module	Voltage Sensing Module
W		
WEA	Wiedereinschaltautomatik	Automatic restart
WZM	Werkzeugmaschine	Machine tool
X		
XML	Extensible Markup Language	Extensible markup language (standard language for web publishing and document management)
Y		
Z		
ZK	DC Link	DC Link
ZM	Zero Mark	Zero mark
ZSW	Status word	Status word

A.2 Documentation overview

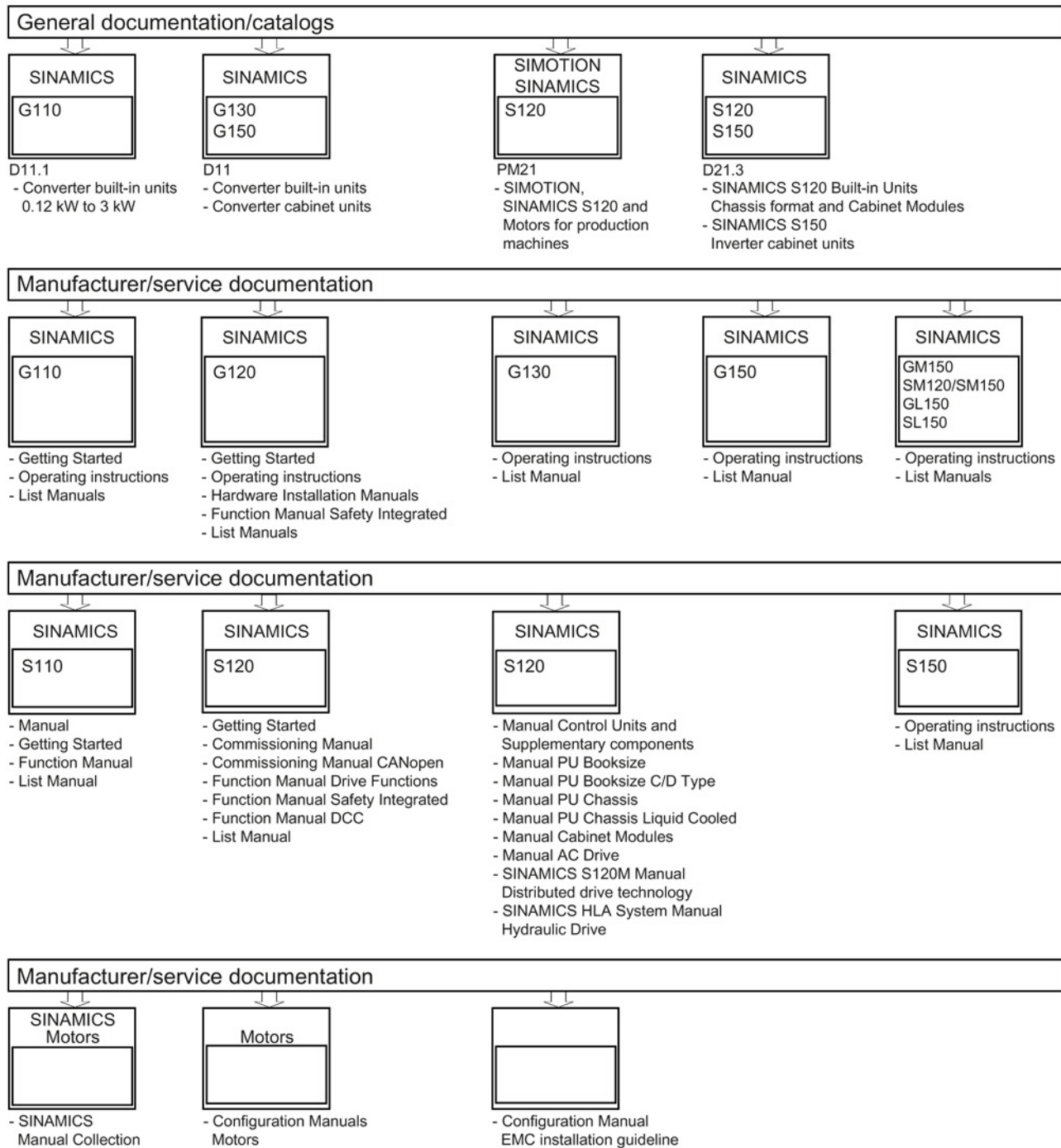

A.3 Spring-type terminals/screw-type terminals

Conductor cross sections that can be connected to the spring-loaded terminals

The type of spring-loaded terminal can be taken from the interface description of the particular component.

Table A- 1 Spring-loaded terminals

Spring-loaded terminal type		
Conductor cross sections that can be connected	Rigid Flexible Flexible with end sleeve without plastic sleeve Flexible with end sleeve with plastic sleeve AWG/kcmil	0.2 ... 1.5 mm ² 0.2 ... 1.5 mm ² 0.25 ... 1.5 mm ² 0.25 ... 0.75 mm ² 24 ... 16
Stripped lengths	10 mm	
Tool	Screwdriver 0.4 x 2.0 mm	

Conductor cross sections that can be connected to the screw-type terminal

Table A- 2 Screw-type terminal

Screw-type terminal		
Conductor cross sections that can be connected	Rigid Flexible Flexible with end sleeve without plastic sleeve Flexible with end sleeve with plastic sleeve AWG/kcmil	0.2 ... 2.5 mm ² 0.2 ... 2.5 mm ² 0.2 ... 2.5 mm ² 0.2 ... 1.5 mm ² 22 ... 12
Stripped lengths	6 ... 7 mm	
Tool	Screwdriver 0.5 x 3 mm	
Tightening torque	0.4 to 0.5 Nm	

Index

2

24 VDC overvoltage protection, 234, 235

A

Auto-transformers, 64

B

Basic Operator Panel BOP20, 165

Braking resistors in Blocksize format, 109

C

Cabinet cooling, 239

Cable installation, 230

CAN, 139

Characteristics

Duty cycles Blocksize PM240-2 Power Modules, 106

Duty cycles for braking resistors in Blocksize format, 118

Circuit-breaker, 36

Communication with USS protocol, 136

Components

Basic Operator Panel BOP20, 165

Braking resistors in Blocksize format, 109

Control Unit CU305 PN, 129

CU305 CAN Control Unit, 129

CU305 DP Control Unit, 129

DRIVE-CLiQ cabinet bushing, 213

DRIVE-CLiQ coupling, 220

Line reactors, 52

Motor reactors, Blocksize, 119

Mounting frame, 222

PM240-2 Blocksize Power Modules, 67

Safe Brake Relay, 208

Sensor Module Cabinet-Mounted SMC10, 170

Sensor Module Cabinet-Mounted SMC20, 181

Sensor Module Cabinet-Mounted SMC30, 190

Connection

Braking resistors in Blocksize format, 111

Line reactors, 56

Motor reactors, Blocksize, 126

PM240-2 Blocksize Power Modules, 77

Safe Brake Relay, 210

Control cabinet design, 227

Control Unit CU305 PN, 129

CU305 CAN Control Unit, 129

CU305 DP Control Unit, 129

D

Diagnostics via LEDs

Sensor Module Cabinet SMC10, 176

Sensor Module Cabinet SMC20, 186

Sensor Module Cabinet SMC30, 199

Dimension drawings

Braking resistors in Blocksize format, 112

Control Unit CU305 PN, 161

CU305 CAN Control Unit, 162

CU305 DP Control Unit, 162

Drilling patterns PM240-2, 91

DRIVE-CLiQ cabinet bushing, 215

DRIVE-CLiQ coupling, 221

Mounting frame, 223

PM240-2 Blocksize Power Modules, 83

Safe Brake Relay, 211

Sensor Module Cabinet SMC10, 177

Sensor Module Cabinet SMC20, 187

Sensor Module Cabinet SMC30, 200

DRIVE-CLiQ cabinet bushing, 213

DRIVE-CLiQ coupling, 220

E

Electronics power supply, 29

EMC category, 44

EMC Directive, 229

EMC environment, 44

Encoder cable length, 143

F

Forming the DC-link capacitors, 248

Fuse, 36

DC link, 109

- H**
- Heat dissipation, 239
- I**
- Installation
 - DRIVE-CLiQ cabinet bushing, 217
 - DRIVE-CLiQ coupling, 221
 - Sensor Module Cabinet, 178, 188, 201
- Interface descriptions
 - Basic Operator Panel BOP20, 165
 - DRIVE-CLiQ cabinet bushing, 214
 - DRIVE-CLiQ cabinet bushing M12, 214
 - DRIVE-CLiQ coupling, 220
 - PM240-2 Blocksize Power Modules, 73
 - Safe Brake Relay, 209
 - Sensor Module Cabinet SMC10, 172
 - Sensor Module Cabinet SMC20, 182
 - Sensor Module Cabinet SMC30, 191
- Interface overview
 - CU305 CAN, 138
 - CU305 DP, 135
 - CU305 PN, 133
- Isolating transformer, 65
- IT system, 58
- L**
- LEDs
 - Sensor Module Cabinet SMC10, 176
 - Sensor Module Cabinet SMC20, 186
 - Sensor Module Cabinet SMC30, 199
- Line contactor, 42
- Line disconnecter, 36
- Line filter versions, 35
- Line frequency, 29
- Line reactor versions, 35
- Line reactors, 52
- Line voltage, 29
- M**
- Memory card, 152
- Motor reactors, Blocksize, 119
- Mounting
 - Basic Operator Panel BOP20, 168
 - Braking resistors in Blocksize format, 115
 - Control Unit CU305 PN, 163
 - CU305 CAN Control Unit, 163
 - CU305 DP Control Unit, 163
 - DRIVE-CLiQ cabinet bushing M12, 218
 - Line filter, 50
 - Motor reactors, Blocksize, 125
 - Mounting frame, 225
 - PM240-2 Blocksize Power Modules, 93
 - Safe Brake Relay, 211
- Mounting frame, 222
- O**
- Overcurrent protection, 36
 - DC link, 109
- Overvoltage protection, 41
- P**
- PM240-2 Blocksize Power Modules, 67
- Potential bonding, 237
- Power loss, 242
 - Control Units, Sensor Modules, 243
 - Line reactors and line filters, 243
 - Motor reactors, 244
 - Power Modules, 243
- Power Supply Units, 236
- Pulse/direction interface, 144
- R**
- Rated pulse frequency, 29
- Rated short-circuit current, 29
- RCD, 40
- RCM, 41
- Replacing
 - PM240-2 fan, 246
- Replacing components, 246
- Replacing the fan
 - PM240-2, 246
- Residual current monitor, 41
- Residual current operated circuit-breakers (RCD), 40
- S**
- Safe Brake Relay, 208
- Safety instructions
 - Braking resistors in Blocksize format, 110
 - Cabinet design, 228
 - Line filter, 43
 - Line reactors, 52
 - Motor reactors, 119
 - Power Modules, 70

- Safe Brake Relay, 208
- Sensor Modules Cabinet-Mounted, 170, 181, 190
- Service and maintenance, 245
- Sensor Module Cabinet-Mounted SMC10, 170
- Sensor Module Cabinet-Mounted SMC20, 181
- Sensor Module Cabinet-Mounted SMC30, 190
- Service and maintenance, 246
- Setting the PROFIBUS address, 137
- Setting the USS address, 137
- Shielding, 230
- Single Phase Grounded Midpoint, 63
- Spare parts, 251
- Specification of encoder systems and encoders
 - Sensor Module Cabinet SMC30, 203
- Spring-loaded terminals, 263

T

Technical data

- Blocksize line filter, 51
- Braking resistors in Blocksize format, 116
- CU305 Control Unit, 164
- DRIVE-CLiQ cabinet bushings, 219
- DRIVE-CLiQ coupling, 222
- Line reactors, 57
- Motor reactors, Blocksize, 127
- PM240-2 Blocksize Power Modules, 97
- Safe Brake Relay, 211
- Sensor Module Cabinet SMC10, 179
- Sensor Module Cabinet SMC20, 189
- Sensor Module Cabinet SMC30, 203
- TN system, 58
- TT system, 58
- Typical 24 V current consumption, 235

V

- Ventilation, 240
- Ventilation clearances, 239
 - PM240-2 Blocksize Power Modules, 71

Siemens AG
Digital Factory
Motion Control
Postfach 3180
91050 ERLANGEN
GERMANY

Subject to change without prior notice
© Siemens AG 2008 - 2015

www.siemens.com/motioncontrol